

A Hallstatt grave containing a cuirass, excavated near Stična by the Duchess of Mecklenburg in 1913 The reliability of grave groups from the Mecklenburg Collection

Dragan BOŽIČ

Izvleček

Grobna celota groba z oklepom iz gomile 52 oziroma IV v Stični, ki ga je leta 1913 izkopala vojvodinja Mecklenburška, je bila že štirikrat predstavljena, vsakokrat nekoliko drugače. Nobena od štirih različic pa se ne ujema povsem s podatki v zapiskih vojvodinjinega tajnika Gustava Goldberga. Od najdb, ki so jih doslej pripisovali grobu, so bili zanesljivo najdeni v njem samo oklep, kernos in lonček. Morda izvirajo iz njega tudi ciborij z nagubanim trupom in sulični osti. Zagotovo pa mu ne pripadajo pokrova, manjša ciborija in 67 kalotastih gumbov z zanko. Manjša ciborija in pokrova so iz kakega drugega stiškega groba, z Magdalenske gore ali celo s kakega drugega grobišča dolenjske halštatske kulture, kalotasti gumbi pa so z grobišča v Stražnem dolu blizu Goleka pri Vinici.

Figuralno okrašena pasna spona s sprevidom moških in ženske, ki jo je Rainer-Maria Weiss pripisal grobu z oklepom iz gomile 52, Biba Teržan pa grobu z dvogrebenasto čelado iz gomile 55 oziroma VI v Stični, ni iz nobenega od teh grobov.

Grobne celote Mecklenburške zbirke so nezanesljive. Med pridatke halštatskih grobov z Magdalenske gore in iz Stične so bile zamešane najdbe iz drugih grobov z istega ali celo z drugega najdišča. V nekaterih so najdbe, ki zagotovo izvirajo s poznohalštatsko-latenskega grobišča v Stražnem dolu blizu Goleka pri Vinici (npr. kalotasti gumbi vrste Vinica, bronasti obročki z izrastki, bronaste igle v obliki pastirske palice in jantarne jagode vrst 8d in 8e po Palavestri). Po drugi strani pa so bile halštatske najdbe, ki jih je vojvodinja izkopala na Magdalenski gori in pri Stični, npr. deli sestavljene čelade, zaključka votle ovratnice in odlomek figuralno okrašene situle, zamešane v nekatere grobne celote iz Stražnega dola blizu Goleka pri Vinici.

Ključne besede: Slovenija, Dolenjska, Stična, Magdalenska gora, Bela krajina, Golek pri Vinici, Metlika; Hrvaška, Grobnik, Kastav, Lika; Bosna in Hercegovina, dolina Une; starejša železna doba, grob z oklepom, mlajša železna doba, kalotasti gumbi vrste Vinica, obročki z izrastki, jantarne jagode, Mecklenburška zbirka

Abstract

The burial deposits from the grave with a cuirass from tumulus 52 or IV at Stična, excavated by the Duchess of Mecklenburg in 1913, have already been published four times and have been differently presented each time. None of the four versions completely corresponds with the data in the notes of the Duchess's secretary, Gustav Goldberg. Of the finds that have previously been attributed to this grave, only a cuirass, a *kernos* and a small pot can definitely be ascribed to it. In addition, a fluted ciborium and spearheads may derive from the grave. Two lids, two smaller ciboria and 67 dome-shaped loop-backed buttons are certainly not from this burial. The smaller ciboria and the lids are from another Stična grave, from Magdalenska gora or perhaps some other cemetery of the Dolenjska (Lower Carniola) Hallstatt culture, while the dome-shaped buttons originate from the cemetery at Stražni dol near Golek pri Vinici.

Rainer-Maria Weiss ascribed a belt-plate with figurative ornament depicting a procession of men and a woman to a grave with a cuirass from tumulus 52. Biba Teržan ascribed the same belt-plate to a grave with a double-crested helmet from tumulus 55 or VI at Stična. However, the belt-plate is not from any of these graves.

The grave groups of the Mecklenburg Collection are unreliable. Finds from other graves from the same or even from a different site have sometimes been added to the Hallstatt period graves from Magdalenska gora and Stična. Some are undoubtedly from the Latest Hallstatt-La Tène cemetery at Stražni dol near Golek pri Vinici (e.g. dome-shaped buttons of the Vinica type, bronze sun rings, bronze shepherd's crook pins and amber beads of Palavestra's types 8d and 8e). Conversely, some grave groups from Golek pri Vinici contain Hallstatt period finds that were excavated by the Duchess on Magdalenska gora and at Stična.

Keywords: Slovenia, Dolenjska, Stična, Magdalenska gora, Bela krajina, Golek pri Vinici, Metlika; Croatia, Grobnik, Kastav, Lika; Bosnia and Hercegovina, the Una valley; Early Iron Age, grave with a cuirass, Late Iron Age, dome-shaped buttons of the Vinica type, sun rings, amber beads, the Mecklenburg Collection

Wells 1981, 55, Tumulus IV:

“Thus I judge the associations in this tumulus to be thoroughly trustworthy.”

INTRODUCTION

Three bronze cuirasses have been discovered in graves of the Slovenian Hallstatt culture, all in the Dolenjska region: two at Stična and one at Kandija near Novo mesto (Dular, Tecco Hvala 2007, 242, note 481, figs. 139 and 141). The cuirass from Novo mesto was the last to be discovered. It was found in 1939 in tumulus 5 at Kandija, during the construction of a sports stadium (Knez 1986,

19f, 51, no. 6, fig. 26: 5); it was not until 1941 that Rajko Ložar examined the rest of the finds from this grave (Gabrovec 1960). A few years earlier, in 1935, a local man, Albin Hrast, discovered the second grave with a cuirass from Stična. It was found in tumulus 40, 41 or 43 of the tumulus cemetery at Stična (Ložar 1937; Gabrovec 1966b, 26, figs. 4–7; Dular 2003, 117, figs. 65 and 66; Gabrovec, Kruh 2006). However, the purpose of the present study is to discuss the first grave with

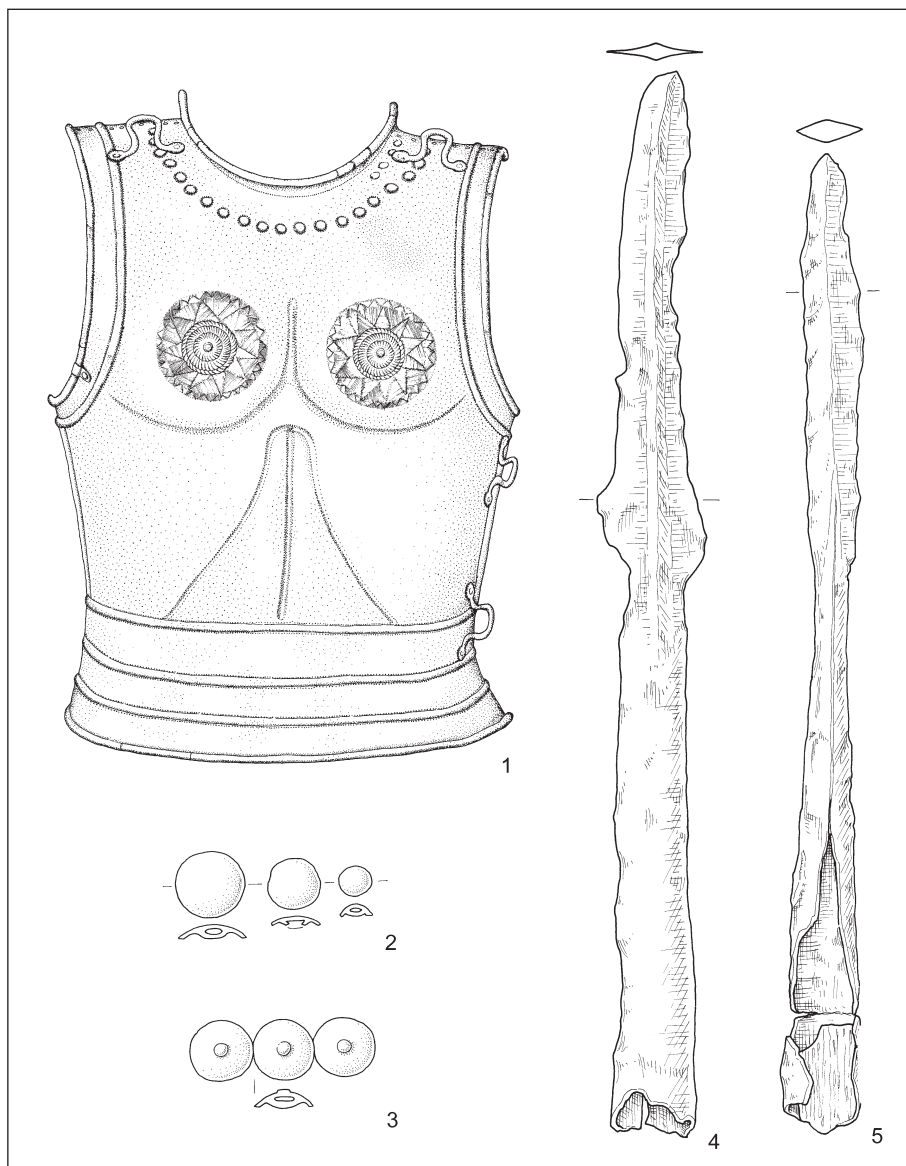

Fig. 1: Metal grave goods from grave 30, tumulus 52 from Stična, after Biba Teržan. Scale 1 = 1:6; 2–5 = 1:2.
Sl. 1: Kovinski pridatki groba 30 gomile 52 iz Stične po Bibi Teržan. M. 1 = 1:6; 2–5 = 1:2.

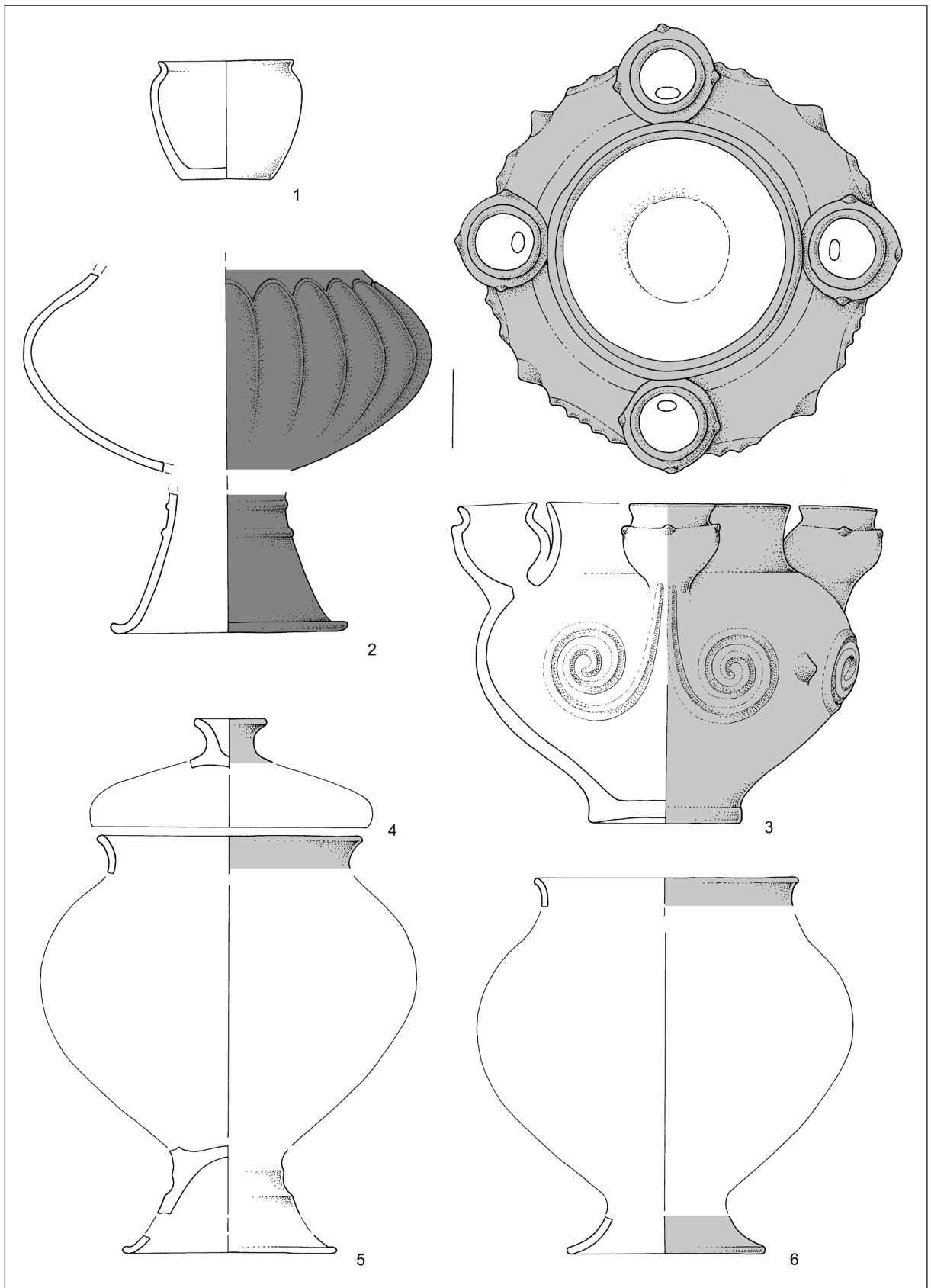

Fig. 2: Ceramic grave goods from grave 30, tumulus 52 from Stična, after Biba Teržan. Scale = 1:4.

Sl. 2: Keramični dodatki groba 30 gomile 52 iz Stične po Bibi Teržan. M. = 1:4.

a cuirass from Stična, opened on 14th April 1913 by the Duchess of Mecklenburg in tumulus 52 of the large Stična tumulus cemetery.

The most recent study of this grave was by Biba Teržan. Her work was published three years ago in the first part of the publication on the Hallstatt tumuli near Stična in Dolenjska (Teržan 2006, 263–266, pls. 207–208 – *figs. 1–2*). In this volume Stane Gabrovec, Ana Kruh, Ida Murgelj and Biba Teržan mainly present finds kept at the National Museum of Slovenia in Ljubljana. This was the fourth publication of the first Stična cuirass grave, which had previously been studied by Gabrovec (1978, 142f, *figs. 5–7 – fig. 4*), Peter S. Wells (1981, 62, *fig. 85*) and Rainer-Maria Weiss (1993). The grave goods are stored in the Peabody Museum of Harvard University in Cambridge, Massachusetts, USA, and in the Museum for Prehistory and Early History in Berlin. Teržan decided that another publication was necessary because in 1992 the cuirass, which for a long time was believed to have been lost, came back to the Museum in Berlin (Teržan 2006, 263).

TUMULUS 52 (TUMULUS IV AFTER THE DUCHESS OF MECKLENBURG)

Between 1905 and 1914 the Duchess excavated 11 tumuli near Stična (Wells 1981, 47). At the time of the excavation the tumulus containing the cuirass grave had been named the Trontelj tumulus (“Gomila Trondel”) or the large tumulus (“grosse Gomila”) at Šentvid (Mahr 1934, 112, cat. no. 126; Gabrovec 1978, 134, *fig. 3*; Weiss 1993, 177, note 26). In the auction sale catalogue of the Mecklenburg Collection it is described as tumulus IV at Šentvid (“St. Veit”) (Mahr 1934, 112–114). The same description was used by Wells in his publication of the Hallstatt period graves from Hallstatt and Stična (Wells 1981, 55–68). It is marked with number 52 on the plan of the Stična tumulus cemetery, which comprises 125 tumuli that were still visible (Gabrovec 1994a, 37, 39, *fig. 26*; Gabrovec *et al.* 2006, 270, *fig. 72*; Dular, Tecco Hvala 2007, 167, 276, cat. no. 98, app. 5). It is located at Vrhpolje pri Šentvidu in a group of tumuli that lay furthest away southward from the Iron Age settlement. Tumulus 125 was adjacent to it on its eastern side. This was excavated in 1906 for the Berlin Museum by Alfred Götze, the head of its prehistoric department, and was fully levelled after excavation (Gabrovec 1978, 132ff, *fig.*



Fig. 3: The first sheet of the card index concerning grave 30, tumulus 52 from Stična. (Held in the Archives of the Peabody Museum, Harvard University. Width of original: 20.8 cm).

Sl. 3: Prvi list kartoteke o grobu 30 gomile 52 iz Stične. (Hrani: Arhiv Muzeja Peabody pri Harvardski univerzi. Širina izvornika 20,8 cm).

3; Gabrovec 1994b; Gabrovec *et al.* 2006, 226ff, *figs. 45 and 46*).

THE GRAVE WITH A CUIRASS (GRAVE 30)

The grave with a cuirass was labelled with reference number 30 at the time of excavation. According to the notes of the Duchess's secretary Gustav Goldberg, transcribed in 1933 in Zurich on the first sheet of the card index referring to this grave (*fig. 3*) by Adolf Mahr, who led the preparations of the Mecklenburg Collection for the auction sale in New York, and to the photographs taken during excavation, the grave pit was 3.1 m long, 1.1 m wide and covered with large stone slabs.¹ A compressed, but well-preserved cuirass lay beneath the slabs, surrounded by three ceramic vessels, two of them exceptionally well made and of very rare forms. One of the two had four small vessels attached to its body. Two iron spearheads, less well preserved, and a few circular buttons had been deposited beneath the cuirass. No other grave goods were present (Wells 1981, 47, 62, *fig. 85: a*; Weiss 1993, 177, note 27, *figs. 10–12*;² Teržan 2006, 264).

In 1977, without knowing about Goldberg's notes and based only on a photograph of an open grave

¹ The Archaeological Department of the National Museum of Slovenia has photocopies of the majority of the card index sheets about this grave (nos. 1, 2, 3b, 3c, 4b and 6), sent to Stane Gabrovec by Hugh Hencken of the Peabody Museum. I would like to thank Janez Dular for bringing my attention to them. The originals are stored in: Mecklenburg Collection Records, #40–77, Box 24, Folder 2, Peabody Museum of Archaeology and Ethnology, Harvard University.

² Weiss mentions that Wells' knowledge of the circumstances of discovery was based on A. Mahr's handwritten notes from 1934 (correctly 1933). These notes presumed to be by Mahr and cited by Weiss word for word in his note are in fact Mahr's transcription of Goldberg's notes from April 14th 1913. His excavation notes are preserved for every grave of tumulus IV (Wells 1981, 55, tumulus IV).

Grab 30

14. 4. 1913

St. Vail gr. vom Grab 30 1/2
 1 Bronzener Gürtel
 3 Tonnen
 2 Eisenlinsen
 2 Eisenlinsen
 2 Eisenlinsen
 2 Eisenlinsen

großes Steinplattenpackung
 Panzer Grab 30

unter Eisenbildung Brandschicht im Boden
 eingeschlagen in Tefl 4'9 m Länge 3'1 m breit 1'10
 tief Boden angeschl. 30 cent im ganzen 5'2 m

mit Steinplatten verdeckt

Funde direkt unter großen Steinplatten ein
 Bronze Panzer durch den Druck der schweren
 Platten in sich zusammengeedrückt sonst
 aber noch sehr gut erhalten, im Kreis
 wurden 3 Tonnen, 2 davon sehr hübsch
 gearbeitet, und sehr seltener Form, am
 oberen Rand der Wanne sind 4 Kl. Wannen

Sonstige Funde im Grab unterhalb
 des Panzers wurden 2 Eisenlinsen ge-
 funden die weniger gut erhalten
 waren sowie einige runde Knöpfe
 sonderbarerweise waren keine anderen
 Sachen vorhanden.

Kl. Wanne
 aus Grab 30. (a)
 gr. Wanne 1/2 Vail
 15 April 1913

(a)	Blech, Panzerst. 2. 1/2
(b)	67 runde Ösen
(c)	Ton, Gefäß mit 4 Aufsatz- Gefäßchen <small>no such vase now with grave Dec 12/1961/HH</small>
(d)	kl. Gefäß
(e)	größeres Gefäß 128
(f)	2 Eis. Linsen <small>2 handles of lists foot of large wmn 6 parts of large graphite wmn 8 part of foot of red wmn</small> <small>perhaps same had</small>

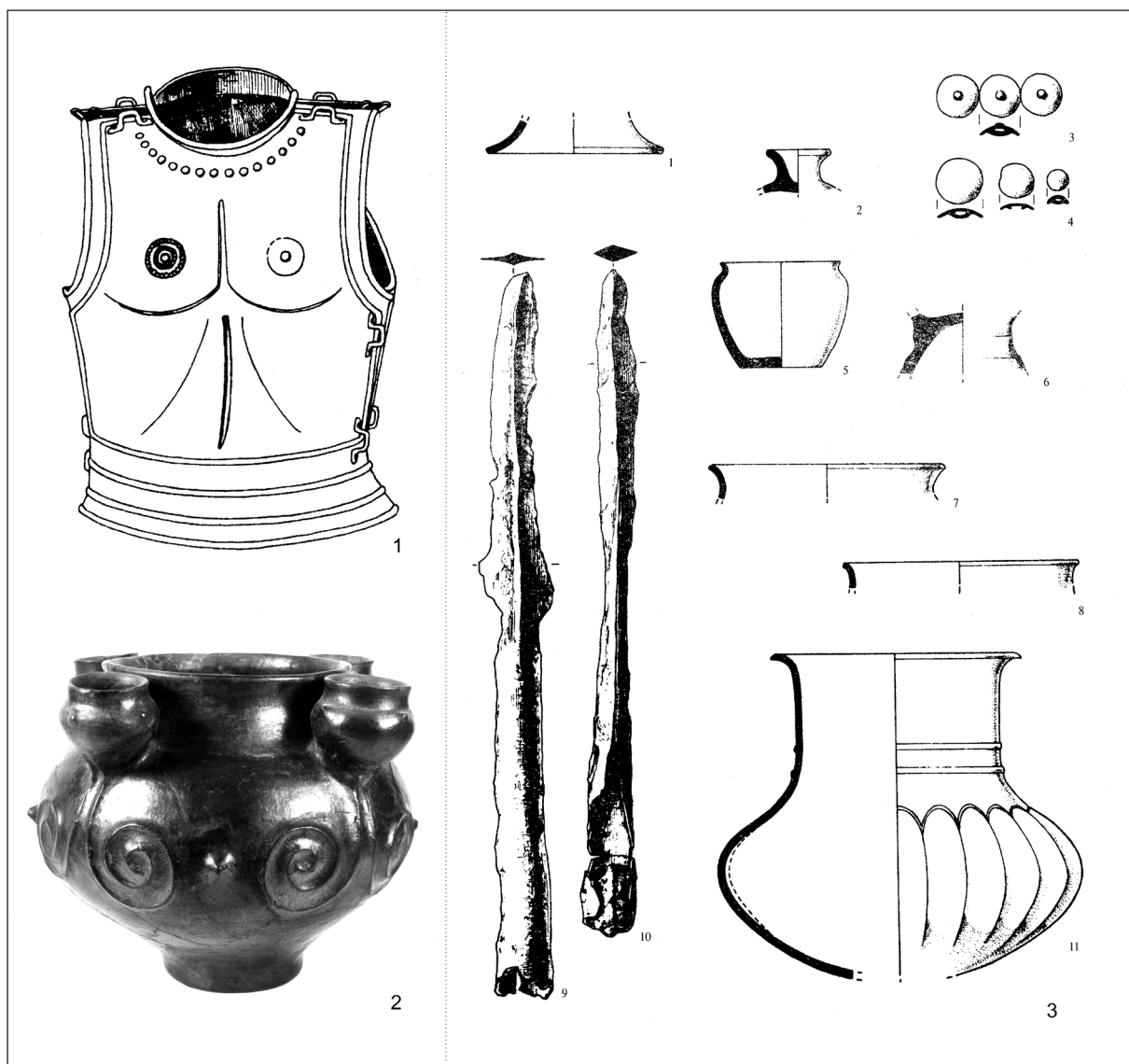

Fig. 4: Grave goods from grave 30, tumulus 52 from Stična, after Stane Gabrovec.
Sl. 4: Pridatki groba 30 gomile 52 iz Stične po Stanetu Gabrovcu.

kept in the National Museum of Slovenia, Gabrovec concluded that, as well as the cuirass, a *kernos* with four small vessels and four antithetic plastic spirals stored in the Berlin Museum belonged to the grave (Gabrovec 1978, 142f, figs. 2 and 5 – fig. 4: 1–2). The Duchess gave the *kernos* together with the cuirass to the German Emperor Wilhelm II. Gabrovec also published a series of drawings of other grave goods (1978, 143, fig. 7 – fig. 4: 3), the first part of which had been assigned to the grave with a cuirass in 1933 in Zurich by Mahr (Dobiat 1982, 1f and 16 – fig. 3: b,d–f) while the second was assigned to it in the Peabody Museum at Harvard University by its head Hugh Hencken (fig. 3: g–j). Hencken and Peter Wells, who was preparing a

publication of these objects at the time, made the drawings available for Gabrovec's study.³ Wells' publication of grave 30, tumulus 52 or IV, offers a description of the circumstances of discovery based upon Goldberg's original notes and description of finds, further photographs of the open grave, the

³ Teržan claims (2006, 263) that neither Wells 1981 nor Weiss 1993 and 1999 mention that Gabrovec was the first who reconstructed the burial deposits from the cuirass grave in his article from 1978. It is true that Wells did not mention Gabrovec's article, which was published three years earlier, but Weiss did acknowledge that Gabrovec had presented for the first time the entire contents, known at that time, of the grave excavated by the Duchess of Mecklenburg (Weiss 1993, 183, note 59).

cuirass and the *kernos*, as well as drawings of the *kernos* and other finds (Wells 1981, 62, 175–177, fig. 85). In this version the grave group consists of the cuirass, spearheads and the *kernos*, three more ceramic vessels and two lids (sherds of a large reddish brown fluted pot with cylindrical neck and reddish slip, a plain light brown small pot, sherds of a brownish ciborium with graphite coating, and sherds of two reddish lids with traces of graphite coating – *ibid.*, fig. 85: h,j,i and k – figs. 4: 3/11; 2: 1,4,5) and also 67 bronze loop-backed buttons, most of which have a small boss in the centre of the obverse (*ibid.*, fig. 85: l,m – fig. 1: 2,3).⁴ There are a few differences to Gabrovec's publication. Three sherds were identified as fragments of a single smaller ciborium by Wells (*ibid.*, fig. 85: i – fig. 2: 5) and as parts of three vessels by Gabrovec (Gabrovec 1978, fig. 7: 6–8): a base and upper part of a foot, an everted rim and the lower edge of a foot, drawn as a rim by Gabrovec (fig. 4: 3/6–8). Moreover, Gabrovec published a drawing of a lower edge of a foot (*ibid.*, fig. 7: 1 – fig. 4: 3/1) that does not appear in Wells.

I have already mentioned that as early as 1913 the Duchess gave the two most valuable grave goods from the cuirass grave, the *kernos* and the cuirass itself, to the German Emperor Wilhelm II, who afterwards provided generous financial support for her excavations. The finds were displayed in the hallway of his Berlin palace until the November revolution in 1918 and were later taken to the Berlin Museum. They were part of a permanent exhibition there, accompanied by a note "on loan from His Majesty the Emperor". In 1945 the Red Army sent the cuirass, together with almost 44,000 other objects from the Museum of Ethnography (the Department for Prehistory and Early History being a part of it) to Saint Petersburg. All this material was transported to Leipzig as part of a secret initiative in 1977 and 1978 and finally started to return to the Museum of Ethnography in Berlin in 1990, after the fall of the Berlin Wall. The Stična cuirass was part of a parcel dated 5th June 1992 (Weiss 1993, 168f and 176f).

⁴ Illustrations of six bronze buttons, spearheads, an undecorated small pot, one of the two lids and a brownish ciborium published by Teržan (figs. 1: 2–5; 2: 1,4,5) are copied from Wells' publication. She does not agree with the reconstruction of the large fluted pot published by Wells (1981, fig. 85: h) and Gabrovec (fig. 4: 3/11), as the pot's cylindrical neck is the hollow foot of a ciborium (Teržan 2006, 266, note 8, pl. 208: 10 – fig. 2: 2).

The return of the cuirass encouraged Weiss to prepare an article about the cuirass grave in the following year (Weiss 1993). He used Wells' published reconstruction of the grave group and added a rectangular belt-plate, decorated in the Situla style (*ibid.*, 181, figs. 15: 9; 16) with a depiction of a crouching animal figure on its right edge with a procession of fifteen males and one female walking towards it. All that was known of this belt-plate was that it was one of the finds from the Carniola sites that have been given to Emperor Wilhelm by the Duchess of Mecklenburg and that it came to Berlin Museum as part of his loan in 1918 (Dobiat 1982, 11f). It was not known where it had been discovered. It was first published by Wolfgang Lucke and Otto-Herman Frey (Lucke, Frey 1962, 71, cat. no. 20, pl. 33) and later by Frauke Geupel (Geupel 1972, 203f, fig. 1). Weiss found out, based on archival documents, that the belt-plate had been among the prehistoric finds given by the Emperor to the Berlin Museum for restoration on 21st October 1913 (Weiss 1993, 181; Weiss 1996, 44, note 20). The belt-plate had a tag saying "Šentvid, Grave with stone slabs 30, 14th April 1913" (*ibid.*, fig. 3, right column below). As the grave with a cuirass was opened on 14th April 1913, covered with stone slabs and labelled as grave 30, Weiss concluded that the belt-plate doubtless originated from this grave.

The grave with a cuirass excavated near Stična by the Duchess of Mecklenburg, and other cuirass graves found in the south-eastern Alpine area, were dated by Weiss to c. 600 BC (Weiss 1993, 185). Moreover, the belt-plate was considered by him to be one of the oldest Slovenian objects ornamented with the Situla style decoration (*ibid.*, 184).

Teržan did not agree with Weiss' assumption that the decorated belt-plate forms a part of the first cuirass grave from Stična. In her publication, which I mentioned at the beginning of this article, she gave two reasons for this (Teržan 2006, 264).⁵ First, Goldberg explicitly mentioned in his notes that, except for the cuirass, spearheads, buttons and

⁵ Teržan expressed her disagreement with Weiss' attribution of the belt-plate to the grave with a cuirass and with his dating of the belt-plate to the time around 600 BC twice before 2006: Teržan 1997, 665, note 44; Teržan 2001, 210, note 15. His assignment of the belt-plate to the grave with a cuirass was also characterized as erroneous by Alexandrine Eibner (2000, 138, note 9) and it was not even accepted by Peter Turk, who dated the belt-plate to the end of the 6th and to the 5th century BC (Turk 2005a, 63, cat. no. 52).

ceramic vessels, there were no other grave goods. Second, she believed that the belt-plate is much later than the cuirass and the remaining grave goods. On the basis of its style it can be dated to the Certosa and the Early Negova horizons.

Two notes stored in the archives of the Berlin Museum (one dated to 27th or 30th October and the other one to 21st November 1913) listed the belt-plate as originating from a grave with stone slabs 30 (Steinplattengrab 30). Teržan therefore believed that the belt-plate belonged to another grave that was labelled similarly to that with the cuirass. Only grave 30 from tumulus 55 or VI, which had a belt-plate listed as a grave good, would be applicable (*ibid.*, 264f).

This grave was not covered with stone slabs according to Goldberg's description (Wells 1981, 80). However, as many as 13 (of 32) graves discovered in tumulus VI had been covered with stone slabs, which makes this tumulus different from all the other tumuli excavated by the Duchess of Mecklenburg at Stična (Mahr 1934, 115, cat. no. 132). Teržan therefore did not doubt ("daher besteht kein Zweifel daran") that grave 30 had also been covered with stone slabs, even though Goldberg did not mention them (Teržan 2006, 267), and chiefly for this reason she ascribed the belt-plate depicting a procession to this grave (*ibid.*, 266–269, fig. 71). According to Goldberg's notes, the grave contained a fragmented double-crested helmet with iron fragments scattered inside and around it, perhaps remains of a shield or harness, and also a badly preserved belt-plate and a fragment of a spearhead (Wells 1981, 80). A helmet and a circular *phalera* with two loops, part of harness, can be seen on a photograph of a block, lifted from the grave (*ibid.*, 212, fig. 160).

THE GRAVE GROUP WITH THE BELT-PLATE WITH AN EXCEPTIONAL FIGURATIVE ORNAMENT REMAINS UNKNOWN

It appears that the belt-plate with a procession of figures was not discovered in grave 30, tumulus IV, as assumed by Weiss, nor in grave 30, tumulus VI, as believed by Teržan.

Goldberg clearly stated that there had been no other finds in the grave with a cuirass except for those listed, which do not include a belt-plate. This militates against Weiss' assumption, as was mentioned by Teržan (2006, 264). Moreover, the style of decoration on the belt-plate itself is not as

old as the cuirass and the other grave goods. This means that the tag "St. Veit, Steinplattengrab 30, 14. April 1913", attached or glued to the belt-plate (Weiss 1993, 181; Weiss 1996, 44, fig. 3), contained the wrong data. A tag with such content definitely referred to the grave with a cuirass from tumulus IV. It could have only been associated with the cuirass or the *kernos* in a parcel with finds from Carniola sent to the Emperor Wilhelm, which was brought to the Emperor's ship in Hamburg by Goldberg, the Duchess's secretary, as early as June 1913 (Gabrovec 1978, 130; Weiss 1993, 176, notes 19 and 20). Who attached it to the belt-plate, and for what reasons, remains unknown.

However, it is evident that the belt-plate is not even from grave 30, tumulus VI. Although as many as 13 graves were covered with stone slabs (Mahr 1934, 115, cat. no. 132), which is almost half the graves from this tumulus, it is not likely that Goldberg would have forgotten to mention that stone slabs covered this particular grave. As with the other burials, he noted the size of this grave and the depth at which it was discovered. As we can see from descriptions published by Wells, graves 3, 6, 9, 10, 12, 13, 14, 15, 19, 22, 23, 24 and 26 were covered with slabs (Wells 1981, 72–79). If grave 30 had also been covered with slabs, then there would be 14 graves covered with slabs. Moreover, zoomorphic and anthropomorphic figures were visible before restoration, which means that the belt-plate was comparatively well preserved (Weiss 1993, 181). Goldberg on the contrary noted that grave 30, tumulus VI, contained a badly preserved belt-plate (Wells 1981, 80), but did not state whether it was iron or bronze. Teržan did not mention that the tag, attached or glued to the decorated belt-plate, also stated the date of 14th April 1913.⁶ Steinplattengrab 30, discovered on that day is undoubtedly grave 30, tumulus IV, which is the grave with a cuirass, and not grave 30, tumulus VI.

There is another reason, which confirms that the decorated belt-plate did not come from grave 30, tumulus VI. The tumulus was excavated between 10th November and 15th December 1913 (Wells 1981, 72). Considering that it contained 32 graves, grave 30 was among the last to be excavated, most

⁶ Incorrect data on this label were obviously cited in the previously mentioned documents stored in the Archive of the Berlin Museum and dating to 27th or 30th October and to 21st November 1913. They note that the belt-plate was discovered in the grave with stone slabs no. 30.

likely in December. The archival documents from the Berlin Museum, mentioned above, prove that the belt-plate came to Berlin as early as the second half of October 1913. This is before they even started to excavate tumulus VI. Moreover, archival documents mentioned by Gloria Polizzotti Greis a few years ago also state the exact date when the Emperor received the belt-plate (Polizzotti Greis 2006, 42–44, notes 26 and 27). The Duchess sent him a new parcel of finds in October 1913, this time with the help of a Swedish archaeologist Oscar Montelius, who had visited her excavations at Stična. He met the Emperor in Bonn on 16th October. As stated in a telegram sent to Montelius by the Duchess on the same day, and from Montelius' letter to the Duchess written right after his meeting with the Emperor, a belt-plate decorated with a unique scene was among the finds. It was particularly valuable for the Emperor. He believed that the figure of an animal depicted a god rather than a votive donation. Weiss notes that the Emperor sent it for restoration only a few days later, on 21st October 1913 (Weiss 1993, 181).

BRONZE BUTTONS

Bronze buttons from the grave with a cuirass

According to Goldberg's notes, the cuirass grave contained a few circular buttons ("einige runde Knöpfe" – Weiss 1993, 177, note 27; Teržan 2006, 264). However, the number of buttons assigned to the grave by Mahr in 1933 is no less than 67 (Mahr 1934, 113, cat. no. 128 – "Gr. 30: sixty-seven bronze buttons with loops"; *fig. 3: b*). Drawings of the same six specimens occur in all four previous publications of the cuirass grave (Gabrovec 1978, 143, *fig. 7: 3,4*; Wells 1981, 62, *fig. 85: l,m*; Weiss 1993, 177, *fig. 15: 3*; Teržan 2006, 265f, pl. 208: 3,4 – *figs. 1: 2,3; 4: 3/3,4*). Three are of the same size and have a central boss on the obverse (*fig. 1: 3*). The other three differ in size and are plain (*fig. 1: 2*). As we can tell from Wells' description, which refers to all 67 buttons, all are dome-shaped and loop-backed. They differ in size, although most have a diameter of 1.6 to 1.7 cm. More than half have a small central boss, which is solid according to the cross-section of one of the buttons.

Gabrovec, Wells and Teržan did not pay them much attention. Weiss mentioned them, but did not engage in a more detailed typological or chronological definition (Weiss 1993, 184, *fig. 15:*

3). He only noted that their purpose was unknown and that they did not tell us much as their position and distribution in the grave were not well documented.

The plain dome-shaped and loop-backed buttons (*fig. 1: 2*) ascribed to the grave do not tell us much, as they are present in different cultural environments of the Urnfield culture and the Early and Late Iron Ages (e.g. Sakara Sučević 2004, 34, bronze dome-shaped buttons of type 1; Blečić 2003; Šribar 1974, 321, no. 23, pl. 3: 10). However, as we will see later, their difference in size is not unimportant. Moreover, buttons with a small solid boss in the centre of the obverse, usually with a wide loop on the reverse, tell a different story (*fig. 1: 3*).

Bronze dome-shaped buttons with a central boss and a loop of type 2 after Sakara Sučević

Maša Sakara Sučević, while studying the material from Kaštelir at Nova vas in Istria, categorised buttons with a central boss on the obverse and a wide loop on the reverse as bronze dome-shaped buttons of type 2 (Sakara Sučević 2004, 34). Type 2 was thought by her to be the latest version of these buttons, which first appeared in the Late Hallstatt period (comp. Dular, Tecco Hvala 2007, 68) and was still used during the La Tène period (Sakara Sučević 2004, 35). Buttons categorised as type 2 by Sakara Sučević can differ widely. Moreover, some even differ from the type as she defined it. To be precise, a button from grave 110 of the Hallstatt period cemetery at Križna gora above Lož (Urleb 1974, 96, pl. 22: 4) is not dome-shaped and has a high solid boss and a comparatively narrow loop. Two buttons from Šmihel pod Nanosom (Guštin 1979, 79, pl. 68: 33 a and c) and one from grave Sz 1484 from Most na Soči (Teržan, Trampuž 1973, pl. 16: 12; Teržan, Lo Schiavo, Trampuž-Orel 1984–1985, 245, pl. 137: 25) do not even have a boss, but a flat apex. Their loops are angular. Buttons from grave Benvenuti 278 in Este have hollow bosses and diametrically arranged small holes on the edges instead of loops (Frey 1969, 15, *fig. 3: 5*).

Only buttons from Kaštelir at Nova vas (Sakara Sučević 2004, 34, *fig. 202 – fig. 5: 4*), Veli Mišincac at Kastav near Rijeka (Guštin 1987, *figs. 7: 7 and 8: 3 – fig. 6: 11,12*) and buttons from grave 52 at Prozor in Lika (Drechsler-Bižić 1972–1973, 50, pl. 28: 14 – *fig. 6: 7*), which were categorised as type 2 after Sakara Sučević, have, just like the majority

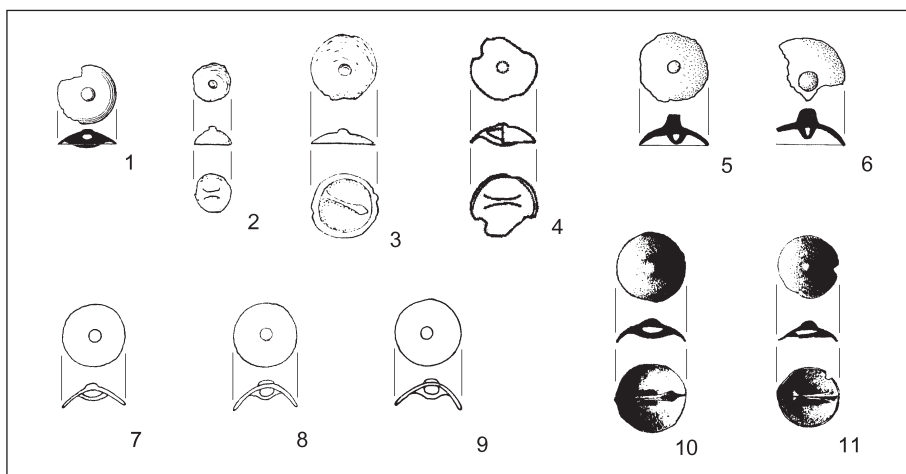

Fig. 5: Bronze dome-shaped buttons of the Vinica type. 1–3 Golek pri Vinici – Stražni dol (1 ascribed to tumulus 55 from Stična – after Wells 1981 and Dobiati 1982); 4 Nova vas – Kaštelir (after Sakara Sučević 2004); 5,6 Nesactium (after Mihovilić 2001); 7,8 Baška, graves 1 and 3 (after Lo Schiavo 1970); 9 Krk (after Lo Schiavo 1970); 10,11 Ribić, graves 33 and 273 (after Marić 1968). Scale = 1:2.

Sl. 5: Bronasti kalotasti gumbi vrste Vinica. 1–3 Golek pri Vinici – Stražni dol (1 pripisan gomili 55 iz Stične, po Wells 1981 in Dobiati 1982); 4 Nova vas – Kaštelir (po Sakara Sučević 2004); 5,6 Nezakcij (po Mihovilić 2001); 7,8 Baška, grobova 1 in 3 (po Lo Schiavo 1970); 9 Krk (po Lo Schiavo 1970); 10,11 Ribić, grobova 33 in 273 (po Marić 1968). M. = 1:2.

of buttons from the Stična cuirass grave (fig. 1: 3), solid bosses and more or less wide loops. Buttons from Nesactium (Mihovilić 2001, 233, pl. 76: 47 – fig. 5: 5,6) are somewhat different. A solid boss with a trapezoid cross-section is very high, while the V-shaped loop is very narrow. Fifteen buttons with a low boss from Grobišće at Grobnik (Blečić 2004, 77, pl. 8: 5.1.11) also possess narrow loops, but they are angular.

Dome-shaped buttons of the Vinica type

(list 1 and fig. 13)

I suggest a term “dome-shaped buttons of the Vinica type” to describe dome-shaped buttons, usually bronze, rarely iron, with a solid boss in centre of the obverse and usually with a wide loop on the reverse. Besides buttons from Nova vas and Nesactium in Istria, from Kastav and from grave 52 at Prozor, some buttons from Ribić in the Una valley (fig. 5: 10,11) and from the island of Krk (fig. 5: 7–9), numerous buttons from Grobnik near Rijeka (fig. 6: 14–16) and four buttons from grave 22 of the La Tène period necropolis Pungart at Metlika (fig. 6: 5) classify as this type. This type of button has not been found in the Early or Late Iron Age graves of Dolenjska. The only exception should be buttons from two Stična tumuli excavated by the Duchess of Mecklenburg, namely the

buttons from the cuirass grave from tumulus 52 or IV (figs. 1: 3; 6: 1) and among the isolated finds from tumulus 55 or VI (fig. 5: 1).

In addition, at least 12 graves from the cemetery Stražni dol near Golek pri Vinici excavated by the Duchess of Mecklenburg (Dular 1985, 106f, figs. 103 and 126) contained this type of buttons.⁷ The Duchess discovered c. 350 flat graves (Polizzotti Greis 2006, 26). Most of the grave goods are now kept in the Peabody Museum at Harvard University; they are, however, almost entirely unpublished (Mahr 1934, 47–56, 85–109, cat. nos. 49–121; Polizzotti Greis 2006, 25–28 and 55, pls. 2; 5–9). Their photographs are available from the Peabody Museum web pages. An advanced search of the museum collections (<http://140.247.102.177/col/advanced.cfm>)⁸ enables the user to search on four data at a time. With a search of place: Vinica (WHERE) and object: button (WHAT), 72 photographs of buttons become available. Numerous dome-shaped buttons of the Vinica type can be recognised from the photographs.

The presence of the Vinica type buttons in two Hallstatt period tumuli from Stična would indicate

⁷ My knowledge of the finds from the flat Latest Hallstatt-La Tène cemetery near Golek pri Vinici was enabled by Michael Geselowitz, who had many years ago sent me photocopies of the drawings.

⁸ Retrieved on Sept. 22. 2009.

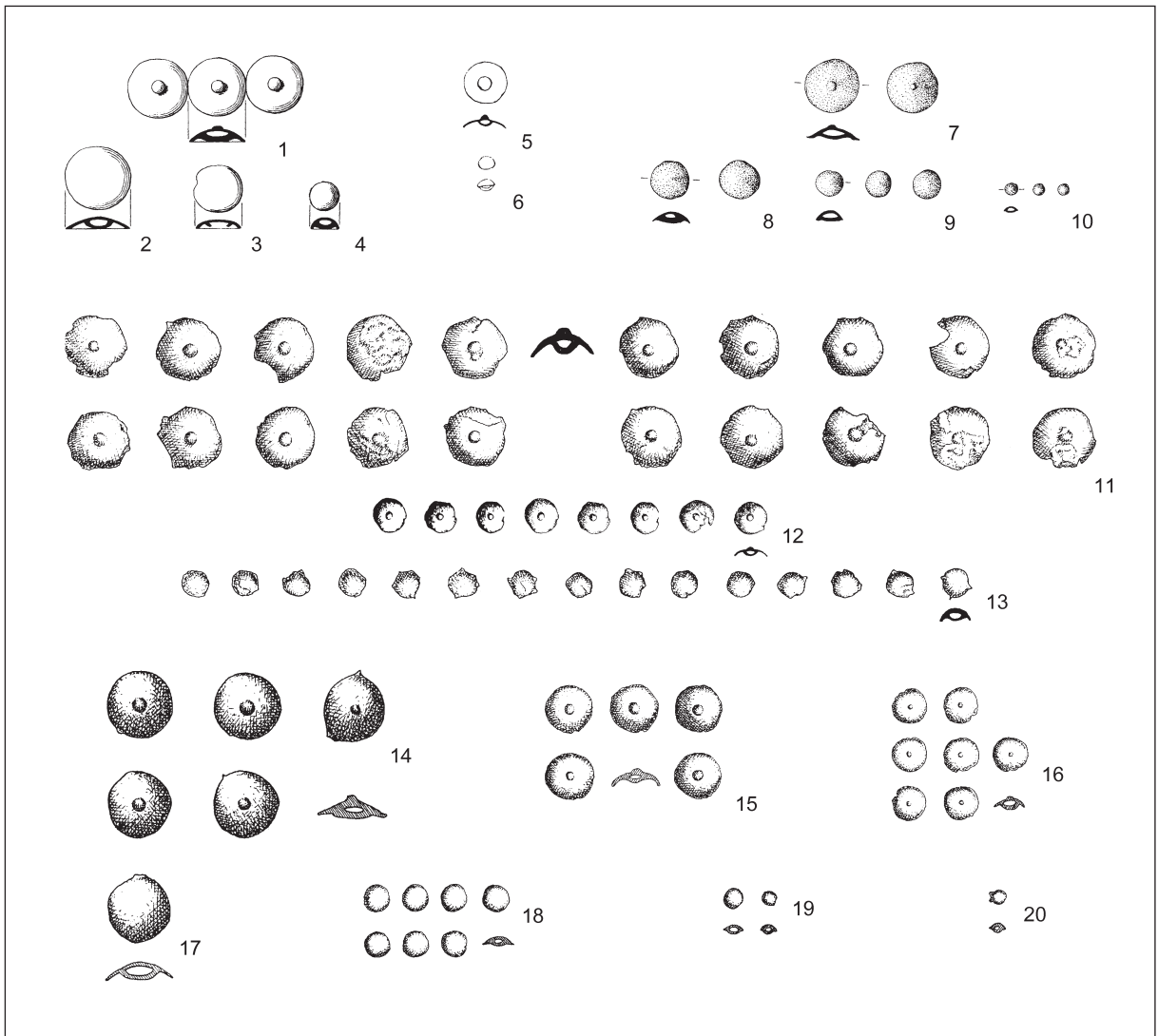

Fig. 6: Bronze dome-shaped buttons (the Vinica type and plain). 1–4 Golek pri Vinici – Stražni dol (ascribed to grave 30, tumulus 52 from Stična – after Wells 1981); 5,6 Metlika – Pungart (grave 22, after Šribar 1974); 7–10 Prozor, grave 52 (after Drechsler-Bižić 1972–1973); 11–13 Kastav – Veli Miščinac (after Blečić 2002); 14–20 Grobnik – Grobišće (after Blečić 2004). Scale = 1:2.

Sl. 6: Bronasti kalotasti gumbi (vrste Vinica in preprosti). 1–4 Golek pri Vinici – Stražni dol (pripisani grobu 30 gomile 52 iz Stične, po Wells 1981); 5,6 Metlika – Pungart, grob 22 (po Šribar 1974); 7–10 Prozor, grob 52 (po Drechsler-Bižić 1972–1973); 11–13 Kastav – Veli Miščinac (po Blečić 2002); 14–20 Grobnik – Grobišće (po Blečić 2004). M. = 1:2.

that they originate from as early as the Hallstatt period. However, as we will see later, the buttons ascribed to the Stična tumuli are not from Stična. It transpires that some of the presumed grave groups from the cemetery Veli Miščinac at Kastav are not reliable grave groups (Blečić 2002, 79). Moreover, grave groups from Golek pri Vinici are neither published nor reliable. It therefore appears that only grave 1/1979 from Kastav, grave 52 from Prozor, grave 2/1987 from Grobnik and grave 22 from Pungart at Metlika can help with dating the Vinica type buttons.

Moreover, the first of these four graves, *i.e.* the grave from Kastav, is not much help. As far as anthropological analysis is concerned, this is a burial of an adult male. Blečić notes that a badly preserved iron knife and four buttons of the Vinica type were discovered in this grave (*ibid.*, 85, 98f, no. 10.8; 100, no. 12, pl. 1: grave 1/1979). Based on the knife, the grave cannot be precisely dated. Nevertheless, Blečić dated it to the La Tène C1 after the central European chronology. This dating was based on a chain pectoral, discovered close by the grave, but outside it (*ibid.*, 85, fig. 5). A

connection of four buttons with a male skeleton is also highly questionable. As seen on a ground plan, only two buttons lay in the grave pit and not four, as claimed by Blečić. The other two buttons lay outside the grave, among bones that, according to Šlaus, belong to an adult donkey, a cow and two humans (*ibidem*).

However, the grave group of the female inhumation grave 52 from Prozor, which has comparatively rich grave goods, is reliable. Besides four bronze fibulae and 114 bronze dome-shaped buttons (plain and the Vinica type), stitched to a leather belt (*fig. 6: 7–10*), it also contained numerous glass and amber beads (Drechsler-Bižić 1972–1973, 50, pls. 27–28; Bakarić 1993). Drechsler-Bižić initially concluded that the grave dated to La Tène D, based on two fibulae with two springs, a true and a false one, and a fibula with a boat-shaped bow (Drechsler-Bižić 1972–1973, 50). She later offered a different date of phase 6 of the Iapodic group, corresponding with La Tène C after the central European chronology or 3rd–2nd centuries BC (Drechsler-Bižić 1987, 411 and 414). Lidija Bakarić did not agree with this and dated the grave to the 1st century BC (Bakarić 1993, 114, cat. no. 96). Sakara Sučević however, accepted this altered date (2004, 35): “Grave can be, based on ... dated to phase 6 of the Iapodic group, *i.e.* 3rd century BC”. Aleksandar Palavestra placed it in his publication on prehistoric amber first to the period between 300 to 1 BC (Palavestra 1993, 82 and 84), and secondly to La Tène C2 (*ibid.*, chronological table on p. 274).

The first date that Drechsler-Bižić suggested, *i.e.* the Late La Tène period, was well founded. It was supported with a statement that fibulae comparable to the fibulae with two springs and the fibula with a boat-shaped bow in grave 52 occur in grave groups from Jezerine and Ribić, ascribed by Marić to his phase Vb, and in the hoard from Lički Ribnik (Drechsler-Bižić 1972–1973, 20 and 50). Fibulae with a boat-shaped bow similar to the one from grave 52 (*ibid.*, 37, pl. 27: 8) have been found in extremely late graves of the Jezerine and Ribić necropoleis (Marić 1968, 34, pls. 5: 6; 16: 20; 17: 12,19,22,23,31; 18: 29,30). Some of them contain fibulae of Jezerine and Alesia types, characteristic of La Tène D2 after the central European chronology (*ibid.*, pls. 5: 7; 16: 21; 18: 31; Božić 2008, 145, tab. 5). Moreover, the latest grave dates as late as the Early Imperial period because of its strongly profiled fibulae (Marić 1968, pl. 17: 29–34). Some of these graves also contain fibulae with two springs and a bead on the bow (*ibid.*,

pls. 5: 3; 16: 22,28; 18: 25,26) and amber beads of Palavestra’s type 10 (*ibid.*, pls. 5: 8,12; 16: 29; 18: 34; Palavestra 1993, typological plate 1 on p. 33). These are forms that are also present in grave 52 from Prozor (Drechsler-Bižić 1972–1973, pl. 27: 1,4–7; Palavestra 1993, 82, 300–1 BC).

Buttons of the Vinica type date to the Late La Tène, according to the evidence from grave 52 from Prozor. Because it is a female burial they were part of a female costume, stitched to a belt together with plain dome-shaped buttons. I have already mentioned that 114 buttons of both types had been preserved in this grave. Their sizes vary a lot; the largest buttons are almost four times as large as the smallest (*fig. 6: 7–10*). Numerous dome-shaped buttons (plain and the Vinica type) found at Kastav and Grobnik were most probably also parts of similar belts; they also occur in various sizes (Blečić 2002, pls. 10 and 11; Blečić 2004, pls. 7 and 8 – *fig. 6: 11–13 and 14–20*).

Inhumation grave 2/1987 from Grobnik also contained a 4 cm wide belt with dome-shaped buttons of two different sizes and two types attached (Cetinić 1996, 195, *fig. 11*; Blečić 2003; Blečić 2004, 57f, 63, 91f, *fig. 17, pl. 1: 1–2*). Two sets of larger buttons were stitched along the edges, with smaller buttons stitched between them in the shape of five-leaf flowers. Blečić did not pay much attention to these buttons, she only noted that they are dome-shaped or half dome-shaped buttons (*ibid.*, 58, 63, 2. Pojasna pločica, 91). She did not publish any drawings of them. A photograph showing a reconstruction of the belt with buttons and two rectangular plates (*ibid.*, *fig. 17*) is small, but still allows us to see that the larger buttons stitched along the edges have a boss in the centre. These are dome-shaped buttons of the Vinica type. In trench 3, where grave 2/1987 was discovered, another 57 buttons of this type were found (*ibid.*, 75, nos. 5.1.1, 5.1.2 and 5.1.3, pl. 7: 5.1.1 and 5.1.2). A cast rectangular belt-plate of Bela Cerkev type attached to the belt (*ibid.*, *fig. 17* and pl. 1: grave 2/1987, no. 2) enables the grave to be dated to the phase Mokronog IIIa or La Tène D1 (Božić 1999, 198). The belt also possessed a rectangular mount with four attachment points, cast in the same mould as the belt-plate.

A fragment of an amber bead, most probably all that remains of a necklace, was also discovered in the grave. The skeleton was very badly preserved. According to the anthropological analysis it was male (Blečić 2004, 58). However, this is very unlikely.

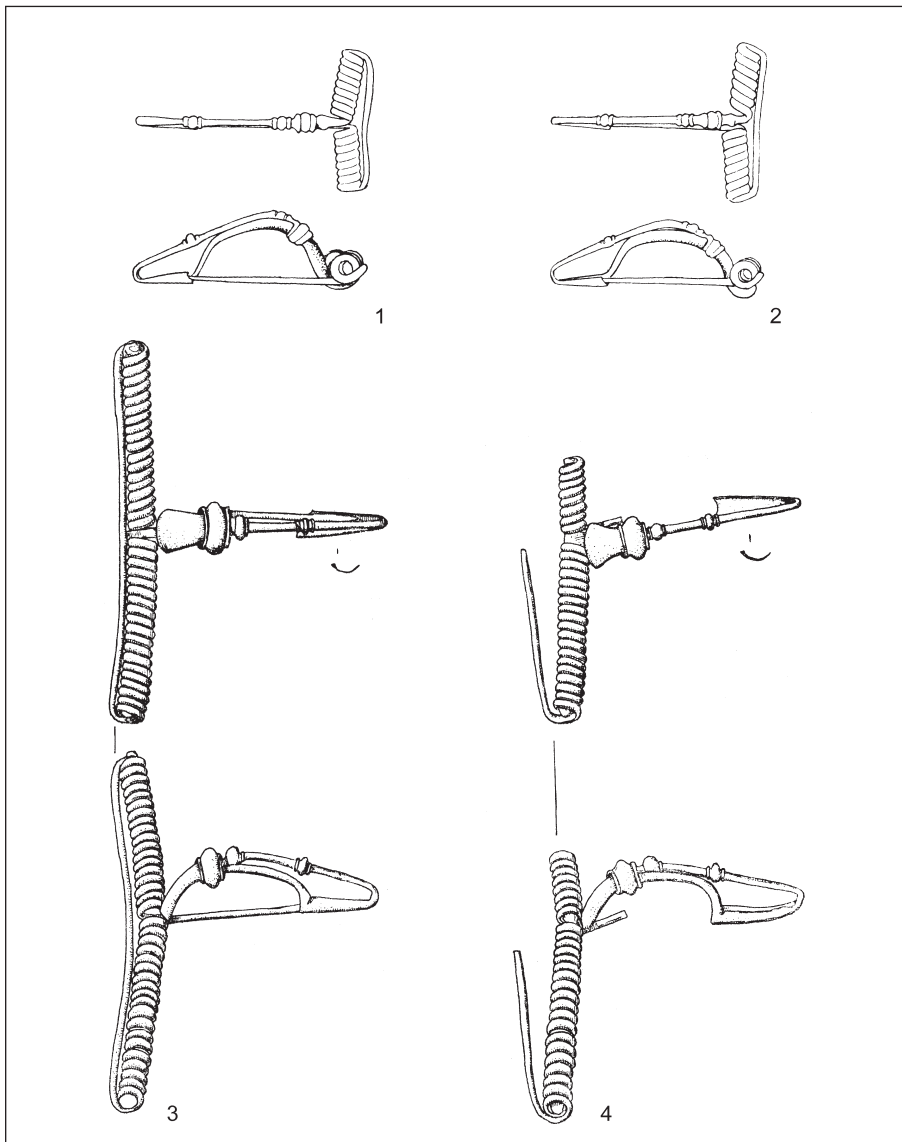

Fig. 7: Silver fibulae of the Middle La Tène scheme with wide springs. 1,2 Metlika – Pungart, grave 22 (after Šribar 1974); 3,4 Bela Cerkev – Strmec (after Stare 1973). Scale = 1:2.

Sl. 7: Srebrne fibule srednjelatenske sheme z dolgo peresovino. 1,2 Metlika – Pungart, grob 22 (po Šribar 1974); 3,4 Bela Cerkev – Strmec (po Stare 1973). M. = 1:2.

Grave 22 from Pungart at Metlika also contained buttons of the Vinica type. It was a cremated female grave with a pair of silver fibulae of the Middle La Tène scheme with wide springs (Šribar 1974, 321, pl. 3: 3,4 – fig. 7: 1,2) and numerous buttons; *i.e.* four larger buttons with a diameter of around 12 mm and c. 100 smaller buttons with a diameter of 4 mm (*ibid.*, pl. 3: 10). Larger buttons have a central boss, which is shown on the drawing in Šribar's paper as hollow, although in reality it is solid (fig. 6: 5,6).⁹

The fibulae have a tripartite clip and two tripartite mouldings, which are flat on the underside and located on the bent part of the foot (Božič 1983, 119, fig. 37). One of the mouldings lies before the clip, and the other just before the bow. Silver fibulae found mostly at Mihovo (Aubelj 1999, fig. on p. 172) but also on Strmec above Bela Cerkev (Stare 1973, 76, nos. 879 and 880, pl. 47: 2,3 – fig. 7: 3,4) are very similar. They were a characteristic of female costume in the Mokronog IIIa period of the Mokronog group (Božič 1999, 198; Božič 2008, 58), which correlates to La Tène D1 after the central European chronology. The only differ-

⁹ Information from Janez Dular.

ence between these fibulae is that the fibulae from Metlika do not have a flat bow and their springs are narrower. The fibulae thus indicate that grave 22 from Metlika and grave 2/1987 from Grobnik, which both contained a belt with large dome-shaped buttons of the Vinica type and with small plain dome-shaped buttons, are contemporary.

Leaving the specimens from Stična aside, we can see that buttons of the Vinica type have a limited distribution, from Istria in the West to the Una valley in the East (*fig. 13*). The ones found in grave 22 from Metlika, in grave 2/1987 from Grobnik¹⁰ and in grave 52 from Prozor were stitched to female belts together with plain dome-shaped buttons. This most probably also applies to buttons from graves at Golek pri Vinici and numerous buttons from Kastav and Grobnik not assigned to grave groups. The evidence from the three graves mentioned dates them to the Late La Tène. That is why it is unlikely that a button, ascribed to grave 3 from Baška (*fig. 5: 8*) really originates from this grave (Lo Schiavo 1970, 426, pl. 24: 14). Two graves from Ribič are already Early Roman and, like grave 3 from Baška, also contained just one button of the Vinica type each. Marić classified these buttons among the earlier forms that still occurred in some graves of period VI in the Una valley (Marić 1968, 37, pls. 20: 20; 22: 3 – *fig. 5: 10, 11*).

A NEW RECONSTRUCTION OF THE GRAVE WITH A CUIRASS FROM STIČNA

As noted before, there are no buttons of the Vinica type in Dolenjska, except for those from Stična. Buttons of this type that have been ascribed to the cuirass grave excavated in 1913 (*figs. 1: 3; 6: 1*) were, judging on the basis of the cited comparisons, stitched to a female belt dating to the Late La Tène period together with plain dome-shaped buttons of three different sizes (*figs. 1: 2; 6: 2–4*). It is, therefore, not possible that they originate from this grave. However, according to Goldberg's notes the grave contained a few circular buttons, which are either not preserved or were assigned to some other grave in the Mecklenburg Collection.

These buttons prove that previous publications of the cuirass grave group are incorrect. Buttons that

¹⁰ As noted before, it is very unlikely that grave 2/1987 from Grobnik belonged to a male.

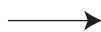

Fig. 8: Stična, grave 30, tumulus 52. Grave goods that do not certainly originate from the grave are marked with a question mark. 1,2,4–7 after Teržan 2006; 3 after Goldberg's notes. Scale 1 = 1:6; 2,4,5 = 1:4; 6,7 = 1:2.

Sl. 8: Stična, grob 30 gomile 52. Z vprašajem so označeni pridatki, katerih pripadnost grobni celoti ni zanesljiva. 1,2,4–7 po Teržan 2006; 3 po Goldbergovih zapiskih. M. 1 = 1:6; 2,4,5 = 1:4; 6,7 = 1:2.

are not only from another grave, but from another site, have been ascribed to this grave instead of the buttons really found in the grave. They date to the Late La Tène and are certainly not from Stična, because Stična tumuli did not contain subsequent burials of the La Tène period (Gabrovec 1994a, 41). They are also not from Magdalenska gora, because no such buttons were found in the Late La Tène graves there. They can only be from Golek pri Vinici, where buttons of the Vinica type, with, as a rule, accompanying plain dome-shaped buttons, were found in at least 12 graves. Moreover, buttons of the Vinica type, appearing among isolated finds from tumulus 55 or VI from Stična (list 1, no. 2 – *fig. 5: 1*), certainly originate from the same site. They were obviously stitched to a female belt together with plain dome-shaped buttons, while three sizes of plain loop-backed buttons also appear among isolated finds from tumulus VI (Wells 1981, 80, isolated finds from tumulus VI, 213, *fig. 161: a*, fourth row). Such a combination precisely corresponds to dome-shaped buttons ascribed to grave 30, tumulus IV (*fig. 6: 1–4*), and to the buttons from grave 52 from Prozor (*fig. 6: 7–10*).

If dome-shaped and loop-backed buttons do not originate from the cuirass grave, the same can also apply to other grave goods. Only objects recognized from descriptions or visible on photographs are certainly from this grave. According to Mahr's transcription of Goldberg's notes (*fig. 3*), three ceramic vessels were deposited in the grave; two of them exceptionally well made and of very rare forms. The first one, marked by Mahr in 1933 with (c), had, according to Goldberg, four small vessels attached to its upper part ("am oberen Rand der Urne sind 4 kl. Urnen"). This is the *kernos* (*figs. 4: 2; 8: 2*), which can also be seen on a photograph.¹¹

¹¹ The Duchess of Mecklenburg had already given the cuirass and *kernos* to the Emperor Wilhelm II in June 1913, two months after the grave with a cuirass was discovered (Weiss 1993, 175ff, notes 19 and 24). Gabrovec was the first to ascribed the *kernos* to this grave, based on a photograph of an open grave, in which the cuirass and *kernos* are visible (Gabrovec 1978, 142f, *fig. 5 – fig. 4: 2*).

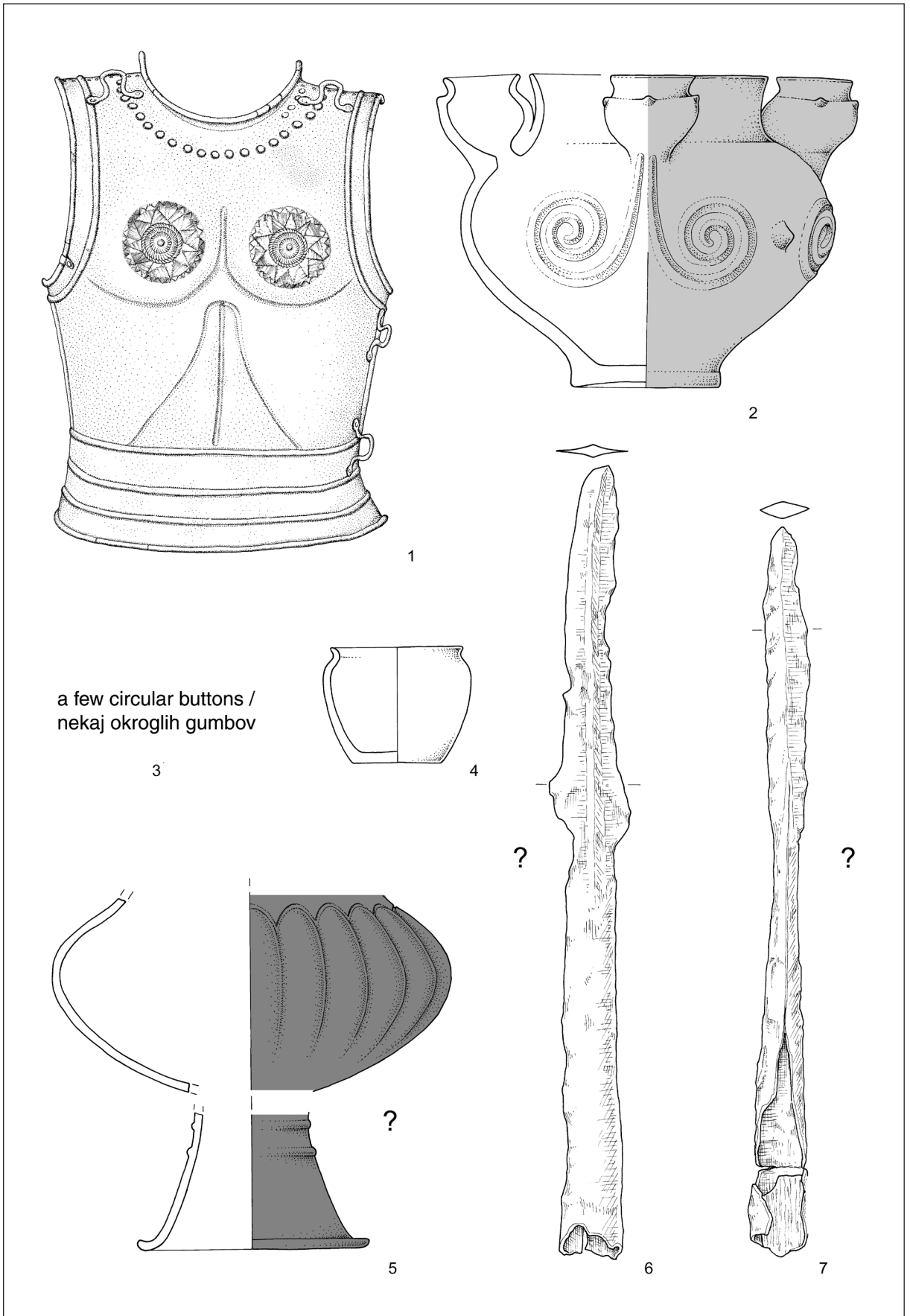

It was missing in Zurich, because it had already been given to the German Emperor in June 1913. In accordance with Goldberg's information about three vessels, in 1933 Mahr assigned two other vessels to the cuirass grave along with the *kernos*. The second vessel, marked by him with (d), was small ("kl. Gefäß") and the third, marked with (e), was larger ("größeres Gefäß"). Only the small pot (fig. 8: 4) could be the afore-mentioned small vessel,¹² clearly labelled with a tag that is now attached to the first sheet of the card index (fig. 3). It says: "Kl Urne aus Grab 30. (d) Gr Gomila St Veit 15 April 1913." In addition, only the large fluted pot (fig. 4: 3/11) could be the afore-mentioned larger vessel, because it was certainly not assigned to the grave in the Peabody Museum, as it does not correspond to Hencken's descriptions (fig. 3: g-j).

According to Wells' and Weiss' publications, in addition to the *kernos*, the small pot and the large fluted pot the grave also contained parts of three other vessels, a smaller ciborium with graphite coating (fig. 2: 5) and two lids (fig. 2: 4), which had been assigned to the cuirass grave by Hencken (fig. 3: g-j). Teržan transformed the large pot into a ciborium (fig. 2: 2) and added another smaller ciborium (Teržan 2006, 266, pl. 208: 7 – fig. 2: 6). She reconstructed it from two fragments, published by Gabrovec (Gabrovec 1978, fig. 7: 1,8 – fig. 4:

Wells, Weiss and Teržan (fig. 2: 3) did the same. The same conclusion might have been reached much earlier especially by some of the prehistorians in the Museum for Prehistory and Early History in Berlin, where the cuirass and *kernos* formed parts of a permanent exhibition from 1922 (Weiss 1993, 177, note 24; Weiss 1999, 64). On a careful reading of the auction sale catalogue, published in 1934 in New York (cfr. Weiss 1993, 182, note 47), it would have been obvious that Ferenc de Tompa from Budapest, in his article about the tumulus cemetery at Stična (Mahr 1934, 59f) mentioned that the late Duchess of Mecklenburg had handed over the bronze cuirass from grave 30, tumulus IV to the former German Emperor and consequently split up the grave group ("The whole grave in which this armor was found was thus split up"). The cuirass from grave 30, tumulus IV, is not mentioned in the catalogue part of the auction sale catalogue. However, other grave goods from this grave are listed: 67 bronze buttons with loops, two iron spearheads and three characteristic ceramic vessels, including a vessel with four small beakers attached to it ("one with four little cups attached to the upper part of the vessel" – *ibid.*, 113, cat. no. 128). This data was misleading for an eventual buyer, as the *kernos*, which arrived in Berlin in 1913, was not auctioned.

¹² Teržan states (2006, 266, pl. 208: 5) that it is 6 cm high. From the 1:4 scale in Wells' publication (Wells 1981, 176, fig. 85: j), it is 8 cm high.

3/1,8). The first is not included in Wells' publication, while the other was considered by him to be the lower edge of a foot and not a rim, as believed by Gabrovec (Wells 1981, fig. 85: i).

As well as the *kernos* (fig. 8: 2), the grave with a cuirass had certainly contained the small pot (fig. 8: 4), which had been labelled with the tag now attached to the first sheet of the card index. As the small pot is plain and of a simple form, Goldberg's data, saying that two out of three vessels are exceptionally well made and of very rare forms, could only refer to the *kernos* and the third vessel. Although this designation (well made and of a very rare form) is still too general for a reliable determination, the fluted ciborium (Teržan 2006, 266, note 8, pl. 208: 10 – fig. 8: 5), which had already been assigned to the cuirass grave by Mahr in 1933, corresponds well to it. If, however, we consider other replacements, this vessel might also have come from another grave. The same applies to the spearheads (fig. 8: 6,7); they could be from the cuirass grave, but they could also come from a different grave. Since according to Goldberg the cuirass grave contained only three ceramic vessels, of which the *kernos* and the small pot could be determined while the third one was exceptionally well made and of a very rare form (maybe the fluted ciborium), it is certain that the fragments of the two lids and of the one or two ciboria with graphite coating that had been assigned to the grave by Hencken are not from this grave.

Considering the above, only the cuirass, the *kernos*, the small pot and a few circular buttons, now lost or in an unknown place, certainly originate from the grave with a cuirass (fig. 8: 1–4). The fluted ciborium and spearheads (fig. 8: 5–7) may also belong to it. The two lids, the one or two smaller ciboria with graphite coating and 67 dome-shaped and loop-backed buttons (of the Vinica type and plain) (figs. 2: 4–6; 1: 2,3) are undoubtedly not from this grave.

THE RELIABILITY OF GRAVE GROUPS FROM THE MECKLENBURG COLLECTION

Grave groups from Stična and Magdalenska gora

In previous literature describing the Mecklenburg Collection, which besides a smaller number of finds from some other sites comprises finds

from Hallstatt, Vače, Hallstatt period tumuli on Magdalenska gora and at Stična and a flat Latest Hallstatt-La Tène cemetery at Golek pri Vinici (Mahr 1934; Hencken 1978; Wells 1981; Dobiak 1982; Polizzotti Greis 2006), it has not been stressed strongly enough that many of the published grave groups are incorrect (comp. Weiss 1996) because the material has been mixed up. It is not yet possible to make the same conclusion for the grave groups from Vače, as they have not been published. However, a lot of finds, doubtlessly originating from Golek pri Vinici, were ascribed to Hallstatt period graves from Stična and Magdalenska gora. This fact has not been so obvious before now, because the majority of the Vinica finds have not yet been published. Finds of “Vinica character” only occur in those graves from Magdalenska gora and Stična that were excavated by the Duchess of Mecklenburg and are now kept in the Peabody Museum. They are not present among the grave goods from graves from these two sites which are kept in the National Museum of Slovenia in Ljubljana and the Natural History Museum in Vienna (Tecco Hvala, Dular, Kocuvan 2004; Gabrovec *et al.* 2006). Moreover, they are, of course, absent from graves from the other Hallstatt period sites in Dolenjska.

Let me mention only some examples. Rings with protrusions, referred to as “sun rings” in the auction sale catalogue of the Mecklenburg Collection and in Hencken’s publication, cast in a two-piece mould, occur in some of the Hallstatt period graves from Magdalenska gora (Mahr 1934, 80, cat. no. 25, grave 30, pl. 7: 25; 82, cat. no. 34, grave 44, pl. 1: 34; Hencken 1978, figs. 63: b; 127: d; 204: e; 265: d; 359: q – *fig. 9: 1*). Such rings are otherwise only known from Golek pri Vinici (Gabrovec 1966a, 179, no. 43, pl. 20: 12,14–16,18; Lo Schiavo 1970, 469, no. 29, pl. 37: 25 – *figs. 9: 2,3; 10*), Podzemelj (Dular 1978, pl. 14: 5) and Sv. Duh in Črnomelj (Božič 1992, 191, note 10).¹³ The La Tène period shepherd’s crook pins, found only at Golek pri Vinici (Gabrovec 1966a, pl. 19: 1–9), Podzemelj (Dular 1978, pls. 15: 23; 16: 1–6; Božič 2001, 196f, figs. 15; 18–20; 198, list 4) and

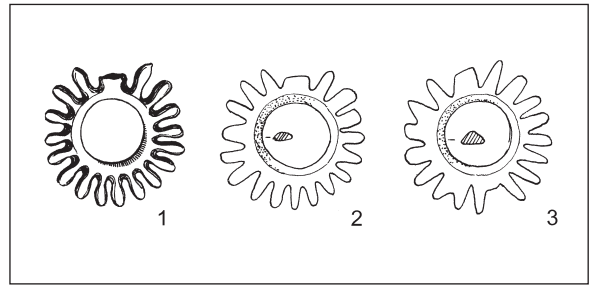

Fig. 9: Golek pri Vinici – Stražni dol. Sun rings (1 ascribed to grave 25, tumulus IV from Magdalenska gora). 1 after Hencken 1978; 2,3 after Gabrovec 1966a. Scale = 1:2.

Sl. 9: Golek pri Vinici – Stražni dol. Obročki z izrastki (1 pripisan grobu 25 gomile IV z Magdalenske gore). 1 po Hencken 1978; 2,3 po Gabrovec 1966a. M. = 1:2.

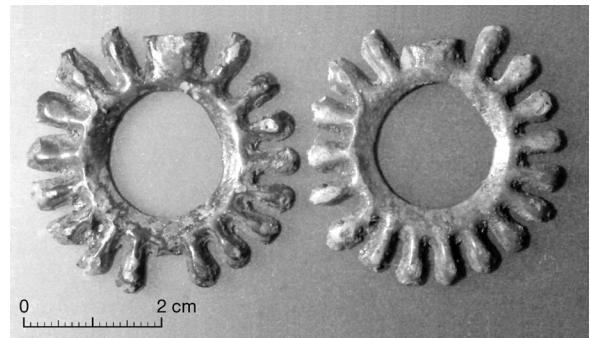

Fig. 10: Golek pri Vinici – Stražni dol. Sun rings. (Photo: Rudolf Berce. Stored by: the Archaeological Department of the National Museum of Slovenia).

Sl. 10: Golek pri Vinici – Stražni dol. Obročka z izrastki. (Foto: Rudolf Berce. Hrani: Arheološki oddelek Narodnega muzeja Slovenije).

Kastav (Blečić 2002, 82f, 92f, cat. no. 2, fig. 4, pl. 1: 2) were ascribed to two Hallstatt graves from the Mecklenburg Collection excavated on Magdalenska gora (Hencken 1978, 24, grave 37, fig. 78: a) and at Stična (Wells 1981, 59, grave 19, fig. 73: a,b), and even occur among isolated finds from the cemetery of Hallstatt (*ibid.*, 24, fig. 27: a).¹⁴ It is obvious from the above examples, that the pins from Golek pri Vinici were added to material from other sites (Božič 2001, 197).

¹³ According to information sent by Phil Mason on 25th May 2009, the sun ring from Črnomelj – 2 fragments of the same ring – was discovered in 1990 in stratigraphic unite 160, *i.e.* in the Late Roman layer of a conical shaped dump of waste material in the northern, external side of the Late Roman defensive tower at the church of Sv. Duh. These finds obviously originate from the Late La Tène layers that were damaged with the construction of the Late Roman fortification.

¹⁴ Wells did not recognize the pin and thought that the fragments probably belonged to one or two handles of a bronze vessel. The pin’s decoration on one side of the head and the lower part, rectangular in cross-section and with a bent terminal, are identical to well preserved shepherd’s crook pins from Podzemelj (Dular 1978, pl. 16: 2,4; Božič 2001, 196f, figs. 15 and 19).

Amber beads of Palavestra's types 8d and 8e

There are many amber beads of special type among the unpublished material from Golek pri Vinici; besides a vertical perforation in the centre, they also have a horizontal tangential perforation. The circumferences of some of the beads are cut out around the terminals of the horizontal perforations. Palavestra (1993, 31, typological plate 1) categorised such beads as type 8d (rounded circumference) or 8e (cut out circumference). He did not know the beads from Vinica. His distribution map (*ibid.*, p. 187) shows that such beads only occur in Lika (Kompolje and Prozor – Bakarić 2004, cat. no. 5.1; Bakarić 2008), at the Jezerine necropolis in the Una valley, on Magdalenska gora, at Stična (Hallstatt period graves of the Mecklenburg Collection) and in the La Tène period grave from Kapiteljska njiva at Novo mesto (Palavestra 1993, 174, types 8d and 8e).

Bead of type 8d from the comparatively early grave 139 at Kompolje (*ibid.*, 77, 750–650, 79, type 8d), discovered during the old Brunšmid excavations, is the only example from the early Hallstatt period. On the Jezerine necropolis, such

beads (see graves, listed *ibid.*, 99, type 8d and grave 264) occur in graves of Marić's phases II, IV, Va, Vb and VI:

phase II: Jezerine 129 and 216 (Radimský 1895, 94f and 112; Marić 1968, 17, note 142 on p. 68);

phase IV: Jezerine 264, 318 and 520 (Radimský 1895, 123, fig. 306, 137 and 177f; Marić 1968, 27, note 221 on p. 73);

phase Va: Jezerine 325 (Radimský 1895, 138, fig. 378 on p. 130; Marić 1968, pl. 4: 12; 32, note 244 on p. 74 – *fig. 11: 2*);

phase Vb: Jezerine 136b and 175 (Radimský 1895, 96 and 104; Marić 1968, 35, notes 272 and 274 on p. 75);

phase VI: Jezerine 68 (Radimský 1895, 81, fig. 127; Marić 1968, pl. 6: 17; 38, note 300 on p. 76).

One of the two graves from phase II, dating from 500 to 360 BC according to Marić (1968, 40), has not been published, *i.e.* inhumation grave 129 containing a semicircular bow fibula, while grave 216, like grave 121a, contained a Certosa type fibula of Xg variant after Teržan (Radimský 1895, 93, fig. 169; 112; Marić 1968, pl. 2: 20 and tab. 3: 85; Teržan 1976, 334). Marić (1968, 17) believed that these two fibulae indicated direct connections with the

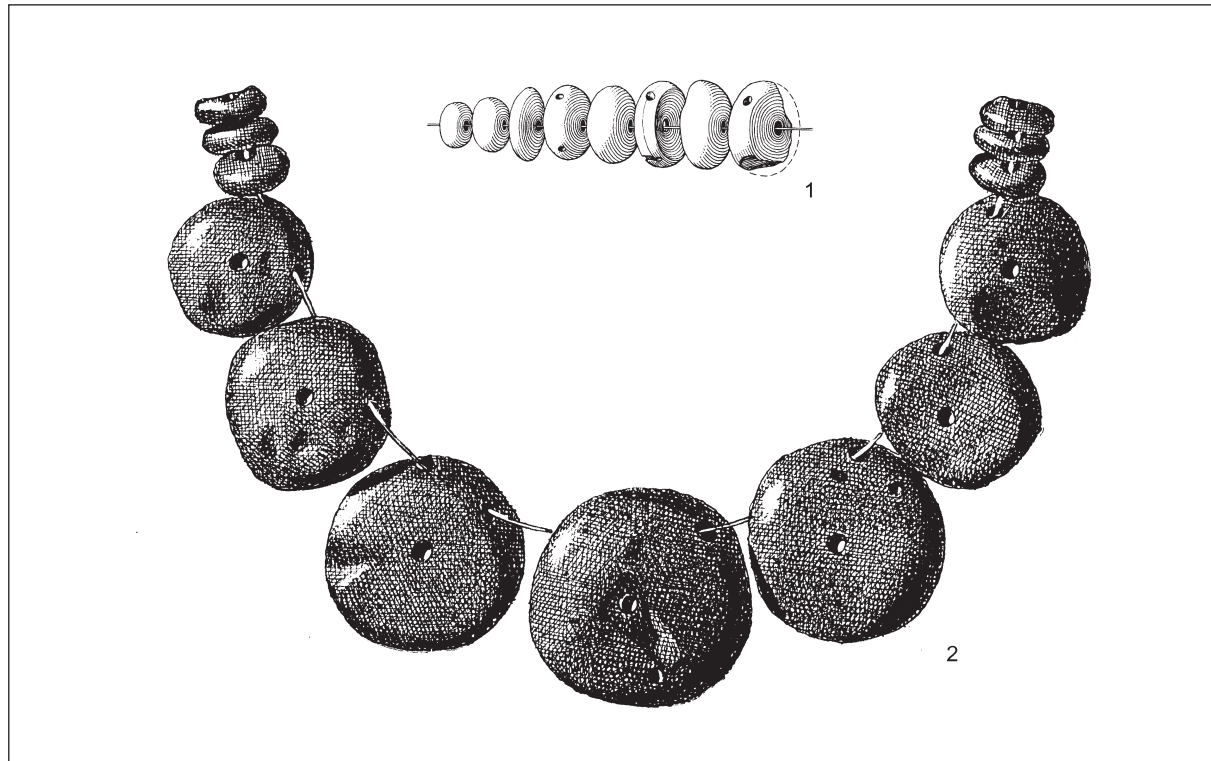

Fig. 11: Amber beads of Palavestra's type 8d. 1 Golek pri Vinici – Stražni dol (ascribed to grave 4, tumulus 52 from Stična – after Wells 1981); 2 Jezerine, grave 325 (after Radimský 1895). Scale = 1:2.

Sl. 11: Jantarne jagode vrste 8d po Palavestri. 1 Golek pri Vinici – Stražni dol (pripisane grobu 4 gomile 52 iz Stične, po Wells 1981); 2 Jezerine, grob 325 (po Radimský 1895). M. = 1:2.

eastern Alpine area and found good comparisons only among finds from Šmihel pod Nanosom. Teržan (1976, 334, fig. 52) showed that fibulae of the Xg variant occurred in Posočje, Notranjska and Kras, in Rijeka hinterland, in Dolenjska, Bela krajina and in the valley of the river Una. She did not agree with Marić's absolute dating of phase II, as it does not have prominent elements that would justify such an early date (*ibid.*, note 164 on p. 421). Graves 121a and 216 containing fibulae of the Xg variant and grave 95 with fibula of the type XII were dated to the first Late Hallstatt horizon of Jezerine graves, which she did not believe began before the middle of the 4th century (*ibid.*, 435).

Considering the dates of the Jezerine graves that contain beads of Palavestra's type 8d, we can claim that they originate from the end of the Hallstatt period and were also used during the whole La Tène period and exceptionally still at the beginning of the Roman period. On the other hand, beads of type 8e perhaps date only to the La Tène period, because they only occur on the necropolis of Jezerine, in graves of Marić's phases III, IV, Va and Vb (see graves, listed in Palavestra 1993, 99, type 8e, and graves 467 and 518):

phase III: Jezerine 103 (Radimský 1895, 87, fig. 154; Marić 1968, 23, note 193 on p. 72 – fig. 12: 1);

phase IV: Jezerine 318, 515, 520 and 524 (Radimský 1895, 137, 176, fig. 570, 178; Marić 1968, 27, notes 221 and 222 on p. 73);

phase Va: Jezerine 308, 359 and 467 (Radimský 1895, 135, 145, fig. 415, 168, fig. 523; Marić 1968, pl. 4: 28; 32, notes 244 and 245 on p. 74 – fig. 12: 2).

phase Vb: Jezerine 518 (Radimský 1895, 177, fig. 575; Marić 1968, 35, note 273 on p. 75).

Some amber beads of type 8e were also discovered in Prozor (Palavestra 1993, 85, type 8e) but cannot be closely dated.

As noted before, beads of types 8d and 8e have been said to derive from Hallstatt period graves on Magdalenska gora and at Stična, all from the Mecklenburg Collection (Magdalenska gora: Hencken 1978, figs. 20: b; 75: a,b; 89: d; 98: a; 262: l,m; 365: c; Palavestra 1993, 174; Stična: Wells 1981, figs. 58: b; 78: a; 84: a; 96: a; 147: c; 150: g; 157: c; Palavestra 1993, 174 – figs. 11: 1; 12: 3), and in the La Tène period grave 35 in tumulus A on Kapiteljska njiva at Novo mesto (Knez 1986, 97, pl. 48: 13).

Beads of types 8d and 8e certainly occur only in graves of the Jezerine necropolis in the Una valley dated from the Latest Hallstatt to the Late La Tène, and exceptionally even the Early Roman period, at Kompolje and Prozor in Lika, in numerous graves at Golek pri Vinici and in one of the La Tène period graves at Novo mesto. They are absent from the Hallstatt period graves in Dolenjska, other than the Mecklenburg Collection graves from Magdalenska gora and Stična. It is therefore evident that beads that have been published as parts of Hallstatt period necklaces from Magdalenska gora and Stična are not from these two sites. Instead, finds from Golek pri Vinici have been mixed up with finds from the Hallstatt period graves from the two Dolenjska sites. Moreover, a necklace, published by Polizzotti Greis as the one originating from Magdalenska gora, can only be from Golek pri Vinici (Polizzotti Greis 2006, 94f, pl. 19).



Fig. 12: Amber beads of Palavestra's type 8e. 1,2 Jezerine, graves 103 and 467 (after Radimský 1895); 3 Golek pri Vinici – Stražni dol (ascribed to grave 25, tumulus 55 from Stična – after Wells 1981). Scale = 1:2.

Sl. 12: Jantarne jagode vrste 8e po Palavestri. 1,2 Jezerine, grobova 103 in 467 (po Radimský 1895); 3 Golek pri Vinici – Stražni dol (pripisane grobu 25 gomile 55 iz Stične, po Wells 1981). M. = 1:2.

Grave groups from Golek pri Vinici

Apart from the Magdalenska gora and Stična grave groups, the ones from Golek pri Vinici are also unreliable. Some of the grave goods from certain Vinica burials were, without a doubt, ascribed to

different graves. Moreover, some finds from the Hallstatt period tumuli from Magdalenska gora and Stična were ascribed to Vinica grave groups. I shall cite just two obvious examples.

According to the auction sale catalogue of the Mecklenburg Collection, Grave 97 from Golek pri Vinici contained remains of a bronze vessel (Mahr 1934, 93, cat. no. 69).¹⁵ These are actually the remains of the rim of a composite helmet;¹⁶ considering the decoration, they belonged to the helmet discovered in grave 15, tumulus V near Stična (Gabrovec 1962–1963, 308, note 65; 321, no. 3, 322, pl. 9: 2; Egg 1980, 246, fig. 3: 1; Wells 1981, 71, grave 15, fig. 125: f; Egg 1986, 167, cat. no. 105, fig. 115: 2, pl. 49: b; Božič 1992, 191, notes 13 and 14). In the same Vinica grave group two terminals shaped like animal heads from a hollow torc also occur.¹⁷ It is highly questionable whether these two objects originate from Golek pri Vinici. Similar terminals have been found mostly in western Slovenia, in Posočje (Most na Soči – Teržan, Lo Schiavo, Trampuž-Orel 1984–1985, 30f, no. 8, hohler Halsring, 368, grave 2337, no. 5, pl. 246: C5; Mlinar 2009, 221, fig. 4: 3; 5), Gorenjska (Mošnje – *ibid.*, 221, note 43) and Notranjska (Šmihel pod Nanosom – Guštin 1979, 78, pl. 65: 7). Two terminals of a single torc have been found at Magdalenska gora in Dolenjska (Tecco Hvala, Dular, Kocuvan 2004, 164, grave 1/1, no. 14, pl. 127: 14; Mlinar 2009, 221, note 39), but they are completely absent eastwards from this site. It is therefore most probable that the terminals from grave 97 at Golek pri Vinici actually originate from Magdalenska gora. There is even a possibility that they, just like the parts of a composite helmet from the same grave, originate from Stična.

Moreover, a fragment of a situla with figurative repoussé ornament supposedly originates from grave 222 at Golek pri Vinici. An ornament of five embossed dots, arranged in a crisscross pattern, can be seen between the rivets that fix the situla body. No other objects decorated in the Situla style were discovered in Hallstatt period graves in Bela krajina. Observing the decoration of the “Vinica” fragment, this is very probably a fragment of a situla from grave 6-7-7a, tumulus V from Magdalenska

gora (Hencken 1978, 30, fig. 111), which has a corresponding fragment missing.

Conclusion

The above article states that grave groups from Magdalenska gora, Stična and Golek pri Vinici, all in the Mecklenburg Collection, have to be studied with extreme caution. If a find cannot be reliably recognized, based on data in Goldberg’s notes, on sketches or in photographs (e.g. like the *kernos* from the grave with a cuirass, which can be seen on a photograph and was described by Goldberg as a ceramic vessel with four small vessels attached), there is no guarantee that it came from the grave to which it has been assigned in publications. It could be from another grave from the same site or even from a different site. If we consider Janez Dular’s report on handling the finds from the Mecklenburg Collection in the period from 1905 to 1933, while the collection was being prepared for the auction in Zürich (Dular 2009), it is not astonishing that numerous transpositions occurred. Finds of the “Vinica character” from the Hallstatt period graves discovered on Magdalenska gora and at Stična doubtlessly originate from Golek pri Vinici.

If I once again mention Peter Wells’ belief, stated at the beginning of this article, that grave groups from Stična, tumulus 52 or IV, after the Duchess of Mecklenburg, are completely reliable, I unfortunately have to argue that this is incorrect. The evidence for this are, e.g., the grave with a cuirass (no. 30), a grave with two shepherd’s crook pins (no. 19 – Wells 1981, 59, fig. 73)¹⁸ and graves from the same tumulus that contain amber necklaces with beads of types 8d and 8e (nos. 4, 23, 29 and 41a). The smaller ciboria and the two lids (Teržan 2006, 266, nos. 7–9 – *fig. 2: 4–6*) ascribed to the cuirass grave are from a different Stična grave, from Magdalenska gora or even from some other site of the Dolenjska Hallstatt culture excavated by the Duchess of Mecklenburg. Dome-shaped buttons (plain and the Vinica type) from the same grave (*fig. 1: 2,3*), two shepherd’s crook pins from grave 19 and amber beads of types 8d and 8e from graves 4 (*fig. 11: 1*), 23, 29 and 41a are, on the contrary, from the cemetery Stražni dol near Golek pri Vinici in Bela krajina.

¹⁵ “69. Vinica, continued: graves 96, 97, 98a, and 98b. Comprising fragments of a rare bronze vessel (?) with herring-bone ornamentation, found in gr. 97. Unfortunately it was only possible to preserve fragments.”

¹⁶ Online collection. <http://140.247.102.177/col/longDisplay.cfm?ObjectKey=117004> [retrieved on Sept. 22. 2009].

¹⁷ Online collection. <http://140.247.102.177/col/longDisplay.cfm?ObjectKey=116417> [retrieved on Sept. 22. 2009].

¹⁸ Teržan and Gabrovec presume, that a bowl-shaped helmet, stored in the Berlin Museum, originates from this grave (Gabrovec *et al.* 2006, 262, pl. 206).

Acknowledgements

Many thanks to Janez Dular for the information on the history of the Mecklenburg Collection and for providing me with some literature. The information on the finds was kindly provided by Martina Blečić Kavur from the Faculty of Philosophy, University of Rijeka and by Phil Mason from the Institute for the Protection of Cultural Heritage of Slo-

venia, Regional Unit Novo mesto. I am grateful to Polona Bitenc, Barbara Jerin, Ida Murgelj and Peter Turk, all from the National Museum of Slovenia in Ljubljana, Manfred Nawroth from the Museum for Prehistory and Early History in Berlin and Patricia Kervick from the Peabody Museum, Harvard University, Cambridge, USA, for their help with the illustrations. Finally, I warmly thank to Nina Crummy from Colchester who kindly checked the translation.

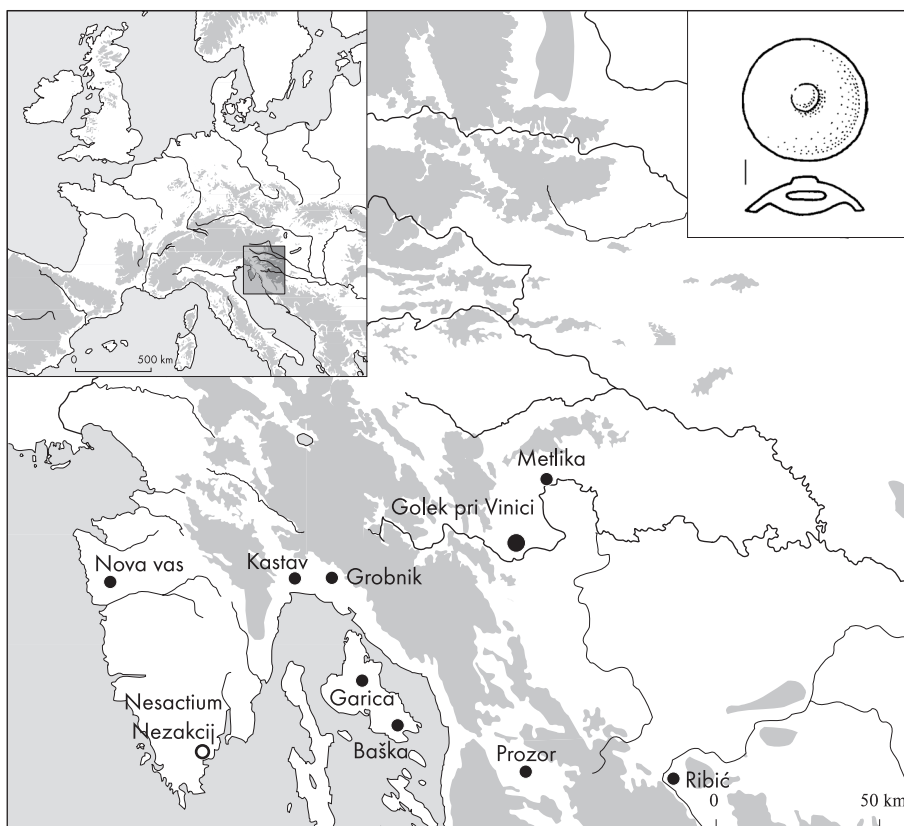

Fig. 13: Distribution map of dome-shaped buttons of the Vinica type (list 1).
Sl. 13: Karta razprostranjenosti kalotastih gumbov vrste Vinica (seznam 1).

LIST 1 (fig. 13)

Dome-shaped buttons of the Vinica type¹⁹

1. Metlika – Pungart, grave 22 (fig. 6: 5)

4 buttons, diam. around 1.2 cm.

Šribar 1974, 321, grave no. 22, no. 23, pl. 3: 10.

2. Golek pri Vinici – Stražni dol, graves 1, 3, 30, 34, 35,

43A, 78, 127, 145, 204, 215 and 277 and isolated finds

Buttons from graves are unpublished.

¹⁹ Dome-shaped buttons of the Vinica type are usually bronze. Apart from the bronze examples, 12 iron buttons were found at Kastav. I am grateful to Martina Blečić Kavur from Rijeka for the information on the buttons from Baška and Garica on the island of Krk, from an unknown site on the island of Krk and from Ribič.

At least 34 buttons with diam. mostly 1.6 to 1.7 cm (ascribed to grave 30, tumulus 52 from Stična – figs. 1: 3; 6: 1).

Wells 1981, 62, grave 30, 176, fig. 85: 1.

A small number of buttons (ascribed to isolated finds from tumulus 55 at Stična – fig. 5: 1).

Wells 1981, 80, isolated finds from tumulus VI, 213, fig. 161: a, third row right.

2 buttons (fig. 5: 2,3).

Dobiat 1982, 43, nos. 3412–3421, pl. 10: 39,45.

3. Nova vas – Kaštelir (fig. 5: 4)

One button, diam. 1.8 cm.

Sakara Sučević 2004, 137, fig. 202.

4. Nesactium (fig. 5: 5,6)

2 buttons, diam. 1.8 cm. Somewhat different.

Mihovilić 2001, 233, pl. 76: 47.

5. **Kastav – Veli Mišinac**, grave 1/1979 and isolated finds (fig. 6: 11,12)

Guštin 1987, 47f, figs. 7: 7; 8: 3.

Cetinić 1996, 196, fig. 12.

Blečić 2002, 97f, cat. no. 10.2 (44 buttons, diam. 1.8 cm and smaller); 98, pl. 10: 10.3 (5 iron buttons, diam. 1.67 cm); 98, pl. 11: 10.5 (20 buttons, diam. 1.75 cm); 98, cat. no. 10.6 (7 iron buttons, diam. 1.7 cm); 85, 98f, pl. 1: 10.8 (grave 1/1979 – 4 buttons, diam. 0.82 cm); 99, pl. 11: 10.09 (8 buttons, diam. 0.83 cm); 99, cat. no. 10.10 (2 buttons, diam. 1.8 cm); 99, cat. no. 10.11 (one button, diam. 1.87 cm).

6. **Grobnik – Grobišće**, grave 2/1987 and isolated finds (fig. 6: 14–16)

Ljubić 1889, 155, no. 11.

Blečić 2004, 57f, fig. 17 (grave 2/1987); 75, pl. 7: 5.1.1 (7 buttons, diam. 0.82–0.93 cm), 5.1.2 (7 buttons, diam. 1.31 cm); 75, cat. no. 5.1.3 (43 buttons, diam. 1.34 cm); 76, pl. 7: 5.1.6 (61 buttons, diam. 1.72 cm); 76, cat. no. 5.1.7 (1 button, diam. 1.24 cm); 77, pl. 8: 5.1.11 (15 buttons, diam. 1.24 cm).

7. **Garica**

Unpublished. Information from Martina Blečić Kavur.

8. **Baška**, graves 1 and 3 (fig. 5: 7,8)

9 dome-shaped buttons (the Vinica type and plain), diam. 1.1 to 1.7 cm (grave 1) and one button, diam. 1.2 cm (grave 3).

Lo Schiavo 1970, 425, grave 1, no. 2, pl. 24: 2; 426, grave 3, no. 3a, pl. 24: 14.

9. **Island of Krk** (fig. 5: 9)

Larger number of different sized buttons.

Lo Schiavo 1970, 425, cat. no. 230, pl. 23: 12a.

10. **Prozor**, grave 52 (fig. 6: 7)

114 dome-shaped buttons of different sizes (the Vinica type and plain) with diam. from 0.4 to 1.5 cm. Buttons were stitched to a leather belt.

Drechsler-Bižić 1972–1973, 37, grave 52, no. 14, pl. 28: 14.

Bakarić 1993, 115, cat. no. 96, n.

11. **Ribić**, graves 33 and 273 (fig. 5: 10,11)

One button, diam. 1.8 cm (grave 33) and the second, diam. 1.6 cm (grave 273).

Čurčić 1900, 9, grave 33; 28, grave 273, no. 9.

Marić 1968, 37, pls. 22: 3; 20: 20.²⁰

²⁰ After the paper had already been finished, Blečić Kavur drew my attention to the Hallstatt period grave 18 of the necropolis of Gradina near Dragišić in Dalmatia, which contained at least two dome-shaped buttons (Brusić 1999, pl. 16: 1,2). Brusić's publication having no catalogue, their position in the grave remains unknown. The larger one has a solid boss, but the smaller is plain. The button with a boss is similar to the buttons of the Vinica type, but it differs from them in having an extremely small opening in the loop and a relatively high boss. Because of these characteristics it is close to the button from grave 19 of the same necropolis (*ibid.*, pl. 17: 6), which also has a very small opening, a still higher boss and a peaked, not rounded, section. Fairly similar to it are the two buttons from Nesactium (fig. 5: 5,6), mentioned above, which differ from the common buttons of the Vinica type.

Grave 18 from Dragišić is undoubtedly female because of the inclusion of amber beads and a bronze needle (*ibid.*, pl. 16: 5,6). As Brusić has published a drawing of just one (*ibid.*, pl. 4: 4) out of 160 dome-shaped buttons in grave 4B of the necropolis near Dragišić (*ibid.*, 8, pl. 27: 2), it is probable that in grave 18 there were in fact more than two buttons. If they lay in the region of the waist, they would have decorated a belt; they may therefore represent a predecessor of the Late La Tène female belts, to which buttons of the Vinica type and plain dome-shaped buttons were attached.

Translation: Nives Kokeza

AUBELJ, B. (ed.) 1999, *Zakladi tisočletij. Zgodovina Slovenije od neandertalcev do Slovanov*. – Ljubljana.

BAKARIĆ, L. 1993, 96. Inventar groba 52. – In: *Arheološki muzej u Zagrebu. Izbor iz fundusa*, 114–115, Zagreb.

BAKARIĆ, L. 2004, 5. Ogrlice (2 kom.) (5. Necklaces [2 specimens]). – In: *Ratnici na razmeđu istoka i zapada* (Warriors at the crossroads of East and West), 359, Zagreb.

BAKARIĆ, L. 2008, 142. Halskette. – In: *Dreitausend Jahre Vorgeschichte. Meisterwerke der Metallzeit im kontinentalen Kroatien*, Schriftenreihe des Keltenmuseums Hochdorf/Enz 7, 194.

BLEČIĆ, M. 2002, Kastav u posljednjem tisućljeću prije Krista (Kastav im letzten Jahrtausend vor Christus). – *Vjesnik Arheološkog muzeja u Zagrebu* 35, 67–146.

BLEČIĆ, M. 2003, Ukrasna pojasna pločica iz Grobnika (Gürtelzierplättchen aus Grobnik). – *Opuscula Archaeologica* 27, 331–335.

BLEČIĆ, M. 2004, Grobnik u željezno doba (Grobnik in the Iron age). – *Vjesnik Arheološkog muzeja u Zagrebu* 37, 47–117.

BOŽIČ, D. (ed.) 1983, *Keltoi. Kelti in njihovi sodobniki na ozemlju Jugoslavije* (Keltoi. Die Kelten und ihre Zeitgenossen auf dem Gebiet Jugoslawiens). – Ljubljana.

BOŽIČ, D. 1992, *Mokronoška skupina latenske kulture v poznolatskem obdobju*. – Unpublished PhD thesis, Faculty of Arts of the University of Ljubljana / Neobjavljena disertacija, Filozofska fakulteta Univerze v Ljubljani.

BOŽIČ, D. 1999, Die Erforschung der Latènezeit in Slowenien seit Jahr 1964 / Raziskovanje latenske dobe

- na Slovenskem po letu 1964. – *Arheološki vestnik* 50, 189–213.
- BOŽIČ, D. 2001, Ljudje ob Krki in Kolpi v latenski dobi / Zur latènezeitlichen Bevölkerung an Krka und Kolpa. – *Arheološki vestnik* 52, 181–198.
- BOŽIČ, D. 2008, *Late La Tène-Roman cemetery in Novo mesto. Ljubljanska cesta and Okrajno glavarstvo. Studies on fibulae and on the relative chronology of the Late La Tène period / Poznolatensko-rimsko grobišče v Novem mestu. Ljubljanska cesta in Okrajno glavarstvo. Študije o fibulah in o relativni kronologiji pozne latenske dobe.* – Katalogi in monografije 39.
- CETINIČ, Ž. 1996, Rezultati novijih arheoloških istraživanja Grobišča (Die Ergebnisse neuerer archäologischer Forschungen auf der Lokalität Grobišče). – *Grobnički zbornik* 4, 188–204.
- ČURČIČ, V. 1900, Ein Flachgräberfeld der Iapoden in Ribič bei Bihač. – *Wissenschaftliche Mitteilungen aus Bosnien und der Herzegowina* 7, 4–32.
- DOBIAT, C. 1982, *Funde aus der Sammlung Mecklenburg.* – Kleine Schriften aus dem Vorgeschichtlichen Seminar Marburg 12.
- DRECHSLER-BIŽIČ, R. 1972–1973, Nekropola prahistorijskih Japoda u Prozoru kod Otočca (Gräberfelder vorgeschichtlicher Iapoden in Prozor bei Otočac). – *Vjesnik Arheološkog muzeja u Zagrebu* 6–7, 1–54.
- DRECHSLER-BIŽIČ, R. 1987, Japodska grupa. – In: *Praistorija jugoslavenskih zemalja* 5, *Željezna doba*, 391–441, Sarajevo.
- DULAR, J. 1985, *Arheološka topografija Slovenije. Topografsko področje* 11 (*Bela krajina*). – Ljubljana.
- DULAR, J. 2003, *Halštatske nekropole Dolenjske / Die hallstattzeitlichen Nekropolen in Dolenjsko.* – Opera Instituti Archaeologici Sloveniae 6.
- DULAR, J. 2009, Kako je nastala in zakaj je odšla na tuje Mecklenburška zbirka (The origin of the Mecklenburg Collection and why it was moved abroad). – *Argo* 52/1–2, 30–47.
- DULAR, J. and S. TECCO HVALA 2007, *South-Eastern Slovenia in the Early Iron Age. Settlement - Economy - Society / Jugovzhodna Slovenija v starejši železni dobi. Poselitev - gospodarstvo - družba.* – Opera Instituti Archaeologici Sloveniae 12.
- EGG, M. 1980, Zum Helmfragment von Magdalenska gora (Fragment čelade z Magdalenske gore). – *Situla* 20–21, 241–249.
- EGG, M. 1986, *Italische Helme. Studien zu den ältereisenzeitlichen Helmen Italiens und der Alpen.* – Monographien / Römisch-Germanisches Zentralmuseum 11.
- EIBNER, A. 2000, Zu den Gürtelblechen von Stična – ein machtgeladenes Symbol der Kriegerausrüstung? – In: B. Gediga, D. Piotrowska (eds.), *Kultura symboliczna kręgu pól popielnicowych epoki brązu i wczesnej epoki żelaza w Europie środkowej / Die symbolische Kultur des Urnenfelderkreises in der Bronze- und frühen Eisenzeit Mitteleuropas*, Prace Komisji Archeologicznej / Polska Akademia Nauk, Oddział we Wrocławiu 13, 129–156.
- FREY, O.-H. 1969, *Die Entstehung der Situlenkunst.* – Römisch-Germanische Forschungen 31.
- GABROVEC, S. 1960, Grob z oklepom iz Novega mesta (Panzergrab von Novo mesto). – *Situla* 1, 27–79.
- GABROVEC, S. 1962–1963, Halštatske čelade jugovzhodnoalpskega kroga (Die hallstättischen Helme des südostalpinen Kreises). – *Arheološki vestnik* 13–14, 293–347.
- GABROVEC, S. 1964–1965, Halštatska kultura v Sloveniji (Die Hallstattkultur Sloweniens). – *Arheološki vestnik* 15–16, 21–63.
- GABROVEC, S. 1966a, Srednjelatensko obdobje v Sloveniji (Zur Mittellatènezeit in Slowenien). – *Arheološki vestnik* 17, 169–242.
- GABROVEC, S. 1966b, Zur Hallstattzeit in Slowenien. – *Germania* 44, 1–48.
- GABROVEC, S. 1978, Dolga pota stiških izkopanin. – *Zbornik občine Grosuplje* 10, 127–145.
- GABROVEC, S. 1994a, *Stična 1, Naselbinska izkopavanja / Siedlungsausgrabungen.* – Katalogi in monografije 28.
- GABROVEC, S. 1994b, Zur Geschichte der Hallstattforschung in Slowenien. – In: *Festschrift für Otto-Herman Frey zum 65. Geburtstag*, Marburger Studien zur Vor- und Frühgeschichte 16, 219–234.
- GABROVEC, S. and A. KRUIH 2006, Gomila 40, 41 ali 43. Grob z oklepom / Grabhügel 40, 41 bzw. 43. Grab mit Panzer. – In: *Gabrovec et al.* 2006, 158–162.
- GABROVEC, S., A. KRUIH, I. MURGELJ and B. TERŽAN 2006, *Stična 2/1, Gomile starejše železne dobe / Grabhügel aus der älteren Eisenzeit.* – Katalogi in monografije 37.
- GEUPEL, F. 1972, Funde der späten Hallstattzeit aus Krajina, Slovenija. – *Forschungen und Berichte* 14, 203–208.
- GUŠTIN, M. 1979, *Notranjska. K začetkom železne dobe na severnem Jadranu / Notranjska. Zu den Anfängen der Eisenzeit an der nördlichen Adria.* – Katalogi in monografije 17.
- GUŠTIN, M. 1987, La Tène fibulae from Istria. – *Archaeologia Jugoslavica* 24, 43–56.
- HENCKEN, H. 1978, *The Iron Age Cemetery of Magdalenska gora in Slovenia.* – Bulletin / American School of Prehistoric Research 32.
- KLEMENC, J. 1935, Ostava u Ličkom Ribniku (Der Schatzfund von Lički Ribnik). – *Vjesnik Hrvatskoga arheološkoga društva* 16, 83–125.
- KNEZ, T. 1986, *Novo mesto 1, Halštatski grobovi / Hallstattzeitliche Gräber.* – Carniola Archaeologica 1.
- LJUBIČ, S. 1889, *Popis arkeološkoga odjela Nar. zem. muzeja u Zagrebu* I/1, *Egipatska sбирka – predhistorička sбирka.* – Zagreb.
- LO SCHIAVO, F. 1970, Il gruppo liburnico-japodico. – *Memorie. Atti della Accademia nazionale dei Lincei, Classe di Scienze morali, storiche e filologiche* 14, 363–525.
- LOŽAR, R. 1934, Predzgodovina Slovenije, posebej Kranjske, v luči zbirke Mecklenburg (Die Vorgeschichte Sloweniens, insbesondere Krains, im Lichte der Sammlung Mecklenburg). – *Glasnik Muzejskega društva za Slovenijo* 15, 5–91.
- LOŽAR, R. 1937, Bronasti oklep z Vrhpolja pri Stični (Armure de bronze provenant de Vrhpolje près de Stična). – *Glasnik Muzejskega društva za Slovenijo* 18, 73–86.
- LUCKE, W. and O.-H. FREY 1962, *Die Situla in Providence (Rhode Island). Ein Beitrag zur Situlenkunst des Osthallstattkreises.* – Römisch-Germanische Forschungen 26.
- MAHR, A. 1934 (ed.), *Prehistoric Grave Material from Carniola excavated in 1905–14 by H. H. the late Duchess Paul Friedrich of Mecklenburg.* – New York.

- MARIČ, Z. 1968, Japodske nekropole u dolini Une. – *Glasnik Zemaljskog muzeja* 23, 5–80.
- MIHOVILIĆ, K. 2001, *Nezakcij. Prapovijesni nalazi 1900. - 1953. / Nesactium. Prehistoric finds 1900 - 1953.* – Monografije i katalozi / Arheološki muzej Istre 11.
- MLINAR, M. 2009, About three Iron Age finds, excavated in the year 1927 at Most na Soči. – In: G. Tiefengraber, B. Kavur, A. Gaspari (eds.), *Keltske študije / Studies in Celtic Archaeology 2, Papers in honour of Mitja Guštin*, Protohistoire Européenne 11, 217–223.
- PALAVESTRA, A. 1993, *Praistorijski čilibar na centralnom i zapadnom Balkanu* (Prehistoric amber in Central and Western Balkans). – Posebna izdanja / Srpska akademija nauka i umetnosti. Balkanološki institut 52.
- POLIZZOTTI GREIS, G. 2006, *A Noble Pursuit. The Duchess of Mecklenburg Collection from Iron Age Slovenia.* – Cambridge, Mass.
- RADIMSKÝ, W. 1895, Die Nekropole von Jezerine in Pritoka bei Bihać. – *Wissenschaftliche Mitteilungen aus Bosnien und der Herzegowina* 3, 39–218.
- SAKARA SUČEVIĆ, M. 2004, *Kaštelir. Prazgodovinska naselbina pri Novi vasi / Brtonigla (Istra)* (Prehistoric Settlement near Nova vas / Brtonigla [Istria]). – Koper.
- STARE, V. 1973, *Prazgodovina Šmarjete.* – Katalogi in monografije 10.
- ŠRIBAR, V. 1974, Žgano srednjelatensko grobišče v Metliki (Brandgräber aus dem mittleren La-Tène in Metlika). – *Arheološki vestnik* 25, 319–352.
- TECCO HVALA, S., J. DULAR and E. KOCUVAN 2004, *Železnodobne gomile na Magdalenski gori / Eisenzeitliche Grabhügel auf der Magdalenska gora.* – Katalogi in monografije 36.
- TERŽAN, B. 1976, Certoška fibula (Die Certosafibel). – *Arheološki vestnik* 27, 317–536.
- TERŽAN, B. 1997, Heros der Hallstattzeit. Beobachtungen zum Status an Gräbern um das Caput Adriae. – In: C. Becker et al. (eds.), *Hrónos. Beiträge zur prähistorischen Archäologie zwischen Nord- und Südosteuropa. Festschrift für Bernhard Hänsel*, Internationale Archäologie. Studia honoraria 1, 653–669.
- TERŽAN, B. 2001, Dolgoživ spomin. Prežitki halštatskega obredja v pustnih šegah na Slovenskem? (A long-lived memory. Can the survival of Hallstatt rituals be seen in carnival celebrations in Slovenia?). – *Arheološki vestnik* 52, 207–219.
- TERŽAN, B. 2006, Gomila IV po vojvodinji Mecklenburški / Grabhügel 52. Grabhügel IV nach Herzogin von Mecklenburg. – In: Gabrovec et al. 2006, 263–269.
- TERŽAN, B. and N. TRAMPUŽ 1973, Prispevek h kronologiji svetolucijske skupine (Contributo alla cronologia del gruppo preistorico di Santa Lucia). – *Arheološki vestnik* 24, 416–460.
- TERŽAN, B., F. LO SCHIAVO and N. TRAMPUŽ-OREL 1984–1985, *Most na Soči (S. Lucia) 2.* – Katalogi in monografije 23.
- TURK, P. 2005a, *Images of life and myth. Exhibition Catalogue.* – Ljubljana.
- TURK, P. 2005b, *Podobe življenja in mita. Katalog arheološke razstave.* – Ljubljana.
- URLEB, M. 1974, *Križna gora pri Ložu. Halštatska nekropola* (Hallstattzeitliches Gräberfeld Križna gora). – Katalogi in monografije 11.
- WEISS, R.-M. 1993, Der Brustpanzer von Stična-St. Veit. – *Acta Praehistorica et Archaeologica* 25, 168–185.
- WEISS, R.-M. 1996, Ein reiches Kreigergrab aus Magdalenska gora – Neue Erkenntnisse zu einem alten Fund. – *Acta Praehistorica et Archaeologica* 28, 40–58.
- WEISS, R.-M. 1999, Des Kaisers alte Funde. Die Sammlung hallstattzeitlicher Funde aus Krain, Slowenien. – In: I. Griesa, R.-M. Weiss, *Hallstattzeit, Die Altertümer im Museum für Vor- und Frühgeschichte* 2, 48–73.
- WELLS, P. S. 1981, *The Emergence of an Iron Age Economy. The Mecklenburg Grave Groups from Hallstatt and Stična.* – Bulletin / American School of Prehistoric Research 33.

K halštatskemu grobu z oklepom, ki ga je leta 1913 pri Stični izkopala vojvodinja Mecklenburška O zanesljivosti grobnih celot Mecklenburške zbirke

Wells 1981, 55, *Tumulus IV:*

“Thus I judge the associations in this tumulus to be thoroughly trustworthy.”
 (“Zato menim, da so grobne celote v tej gomili popolnoma zanesljive.”)

UVOD

V grobovih halštatske kulture v Sloveniji so bili odkriti trije bronasti oklepi, vsi trije na Dolenjskem: dva pri Stični in eden v Kandiji pri Novem mestu (Dular, Tecco Hvala 2007, 242, op. 481, sl. 139 in 141). Novomeški oklep je bil odkrit kot zadnji leta 1939 pri gradnji športnega stadiona v gomili 5 v Kandiji (Knez 1986, 19 s, 51, št. 6, sl. 26: 5), sam grob pa je šele leta 1941 raziskal Rajko Ložar (Gabrovec 1960). Samo nekaj let pred tem, leta 1935, je domačin Albin

Hrast v gomili 40, 41 ali 43 stiškega gomilnega grobišča izkopal drugi grob z oklepom iz Stične (Ložar 1937; Gabrovec 1964–1965, 34, op. 53, t. 2–5; Dular 2003, 117, sl. 65 in 66; Gabrovec, Kruh 2006). Predmet pričujoče študije pa je prvi grob z oklepom iz Stične, ki ga je 14. aprila 1913 v gomili 52 velikega stiškega gomilnega grobišča odprla vojvodinja Mecklenburška.

Zadnjo predstavitev tega groba je pripravila Biba Teržan pred tremi leti v prvem delu publikacije o halštatskih gomilah v okolici Stične na Dolenjskem (Teržan 2006, 263–266, t.

207–208; *sl.* 1–2). V njem Stane Gabrovec, Ana Kruh, Ida Murgelj in Teržanova predstavljajo predvsem najdbe, ki se hranijo v Narodnem muzeju Slovenije v Ljubljani. To je že četrta objava tega groba, ki so ga pred tem objavili Gabrovec (1978, 142 s, *sl.* 5–7; *sl.* 4), Peter S. Wells (1981, 62, *sl.* 85) in Rainer-Maria Weiss (1993). Njegove pridatke hranijo v Muzeju Peabody Harvardske univerze v Cambridgeu v ZDA in v Muzeju za prazgodovino in zgodnjo zgodovino v Berlinu. Teržanova se je odločila za ponovno objavo zato, ker je oklep, ki je dalj časa veljal za izgubljenega, leta 1992 spet prišel v berlinski muzej (Teržan 2006, 263).

GOMILA 52

(GOMILA IV PO VOJVODINJI MECKLENBURŠKI)

Vojvodinja je v času med 1905 in 1914 v bližini Stične izkopal 11 gomil (Wells 1981, 47). Gomila, ki je vsebovala grob z oklepom, je bila v času izkopavanja imenovana gomila Trontelj ("Gomila Trondel") ali velika gomila ("grosse Gomila") pri Šentvidu (Mahr 1934, 112, kat. št. 126; Gabrovec 1978, 134, *sl.* 3; Weiss 1993, 177, op. 26). V dražbenem katalogu Mecklenburške zbirke nosi oznako gomila IV pri Šentvidu ("St. Veit") (Mahr 1934, 112–114), ki jo je zadržal tudi Wells v svoji knjigi o halštatskih grobovih iz Hallstatta in Stične (Wells 1981, 55–68). Na načrtu stiškega gomilnega grobišča, ki obsega 125 še vidnih gomil, je označena s številko 52 (Gabrovec 1994a, 40, *sl.* 26; Gabrovec et al. 2006, 270, *sl.* 72; Dular, Tecco Hvala 2007, 167, 276, kat. št. 98, pril. 5). Leži v Vrhpolju pri Šentvidu v skupini gomil, ki so v smeri proti jugu najbolj oddaljene od železnodobnega naselja. Proti vzhodu je bila tik ob njej gomila 125, ki jo je za berlinski muzej leta 1906 izkopal vodja prazgodovinskega oddelka Alfred Götze in je bila po izkopavanju povsem zravnana (Gabrovec 1978, 132 ss, *sl.* 3; Gabrovec 1994b; Gabrovec et al. 2006, 226 ss, *sl.* 45 in 46).

GROB Z OKLEPOM (GROB 30)

Grob z oklepom je dobil med izkopavanjem zaporedno številko 30. Iz zapiskov tajnika vojvodinje Gustava Goldberga, ki jih je leta 1933 v Zürichu na prvi list kartoteke groba z oklepom (*sl.* 3) prepisal Adolf Mahr, ki je vodil pripravo Mecklenburške zbirke za dražbo v New Yorku, in s fotografij, posnetih ob izkopavanju, izhaja, da je bila 3,1 m dolga in 1,1 m široka grobna jama pokrita z velikimi kamnitimi ploščami.¹ Pod njimi so ležali stisnjen, sicer pa zelo dobro ohranjen oklep in okoli njega tri keramične posode, dve od njih zelo lepo izdelani in zelo redke oblike. Ena od teh dveh je imela na robu 4 posodice. Pod

¹ Arheološki oddelek Narodnega muzeja Slovenije hrani fotokopije večine kartotečnih listov o tem grobu (št. 1, 2, 3b, 3c, 4b in 6), ki jih je Stanetu Gabrovcu poslal Hugh Hencken iz Muzeja Peabody. Nanje me je ljubeznivo opozoril kolega Janez Dular. Izvirniki so shranjeni v arhivu Mecklenburške zbirke, #40–77, škatla 24, mapa 2, ki ga hrani Muzej Peabody za arheologijo in etnologijo pri Harvardski univerzi.

oklepom so ležali še dve slabše ohranjeni železni sulični osti in nekaj okroglih gumbov. Drugih pridatkov v grobu ni bilo (Wells 1981, 47, 62, *sl.* 85: a; Weiss 1993, 177, op. 27, *sl.* 10–12;² Teržan 2006, 264).

Gabrovec je leta 1977, ko še ni poznal Goldbergovih zapiskov, samo na podlagi fotografije odprtega groba, ki jo hrani Narodni muzej Slovenije, ugotovil, da sodi vanj poleg oklepa tudi kernos s štirimi čašicami in štirimi antitetičnimi plastičnimi spiralami, shranjen v berlinskem muzeju (Gabrovec 1978, 142 s, *sl.* 2 in 5; *sl.* 4: 1–2). Vojvodinja ga je hkrati z oklepom podarila nemškemu cesarju Wilhelmu II. Gabrovec (1978, 143, *sl.* 7; *sl.* 4: 3) je objavil tudi risbe drugih pridatkov, katerih prvi del je grobu z oklepom leta 1933 v Zürichu pripisal Mahr (Dobiat 1982, 1 s in 16; *sl.* 3: b,d-f), drugega pa šele v Muzeju Peabody pri Harvardski univerzi njegov direktor Hugh Hencken (*sl.* 3: g-j). Na razpologo sta mu jih dala Hencken in Peter Wells, ki je takrat že pripravljaval njihovo objavo.³

Wellsova objava groba 30 gomile 52 oziroma IV vsebuje poleg opisa najdiščnih okoliščin, ki temelji na Goldbergovih izvirnih zapiskih, in opisov najdb tudi fotografije odprtega groba, oklepa in kernosa ter risbe kernosa in drugih najdb (Wells 1981, 62, 175–177, *sl.* 85). Grobna celota obsega poleg oklepa, suličnih osti in kernosa še tri keramične posode in dva pokrova (črepinje velikega rdečkasto rjavega lonca z nagubanim trebuhom, valjastim vratom in rdečkastim premazom, neokrašen svetlorjav lonček, črepinje rjavkastega ciborija z grafitnim premazom in črepinje dveh rdečkastih pokrovov s sledovi grafitnega premaza, *ib.*, *sl.* 85: h,j,i in k; *sl.* 4: 3/11; 2: 1,4,5) ter 67 bronastih gumbov z zanko na spodnji strani, ki imajo na sredini večinoma majhno izboklino (*ib.*, *sl.* 85: l,m; *sl.* 1: 2,3).⁴ V primerjavi z Gabrovčevo objavo je nekaj drobnih razlik. Wells je eni sami posodi, in sicer manjšemu ciboriju (*ib.*, *sl.* 85: i; *sl.* 2: 5), pripisal tri dele, ki jih je bil Gabrovec opredelil kot dele treh posod (Gabrovec 1978, *sl.* 7: 6–8): dno in zgornji del noge, izvihano ustje in spodnji rob noge, ki je

² Weiss navaja, da se je Wells pri svojih izvajanjih glede najdiščnih okoliščin oprl na rokopisne zapiske A. Mahra iz leta 1934 (prav 1933!). Domnevni Mahrovi zapiski, ki jih je Weiss v opombi dobesedno navedel, so Mahrov prepis zapiskov tajnika Goldberga z dne 14. aprila 1913. Njegovi izkopavalni zapiski so ohranjeni za vsak grob gomile IV (Wells 1981, 55, gomila IV).

³ Po Teržanovi (2006, 263) niti Wells l. 1981 niti pozneje Weiss l. 1993 ali 1999 nista omenila, da je sestav groba z oklepom ponovno rekonstruiral prav Gabrovec v članku iz leta 1978. Wells Gabrovčevega članka, ki je izšel tri leta pred njegovo knjigo, res ni omenil, Weiss pa ga je, in sicer z besedami, da je Gabrovec v njem prvič predstavil popolno takrat znano vsebino groba, ki ga je izkopal vojvodinja Mecklenburška (Weiss 1993, 183, op. 59).

⁴ Risbe šestih bronastih gumbov, suličnih osti, neokrašenega lončka, enega od dveh pokrovov in rjavkastega ciborija v objavi Teržanove (*sl.* 1: 2–5; 2: 1,4,5) so prerisane po Wellsovi objavi. Po njenem mnenju je risarska rekonstrukcija velikega lonca z nagubanim trebuhom, ki jo je pred Wellsom (1981, *sl.* 85: h) objavil že Gabrovec (*sl.* 4: 3/11), napačna. Valjasti vrat lonca naj bi bil dejansko votla noga ciborija (Teržan 2006, 266, op. 8, t. 208: 10; *sl.* 2: 2).

pri Gabrovcu narisano kot ustje (*sl. 4: 3/6–8*). Gabrovec je poleg tega objavil risbo spodnjega roba noge (*ib., sl. 7: 1; sl. 4: 3/1*), ki je pri Wellsu ni.

Omenil sem že, da je vojvodinja dva najdragocenejša pridatka groba z oklepom, sam oklep in kernos, že leta 1913 poklonila nemškemu cesarju Wilhelmu II., ki je izdatno financiral njena izkopavanja. Do novembrske revolucije leta 1918 sta bila razstavljena v predsobi cesarja v Mestnem gradu, potem pa sta bila prenesena v muzej, kjer sta bila z oznako "na posodo od njegovega veličanstva cesarja" vključena v stalno razstavo. Leta 1945 je Rdeča armada oklep skupaj s skoraj 44.000 predmeti Muzeja za narodopisje, h kateremu je sodil Oddelek za prazgodovino in zgodnjo zgodovino, odpeljala v Sankt Peterburg. Vse to gradivo je bilo v letih 1977 in 1978 v tajni akciji prepeljano v Leipzig, po padcu berlinskega zidu pa je leta 1990 končno pričelo prihajati nazaj v Muzej za narodopisje v Berlinu. V pošiljki z dne 5. junija 1992 je bil med drugim stiški oklep (Weiss 1993, 168 s in 176 s).

Vrnitev oklepa je spodbudila Weissa, da je že naslednje leto o grobu z oklepom pripravil članek (Weiss 1993). Pri rekonstrukciji grobne celote se je naslonil na Wellsovo objavo, vanjo pa je vključil tudi pravokotno pasno spono, okrašeno v situlskem slogu (*ib., 181, sl. 15: 9; 16*). Na njej je poleg čepeče živalske figure na desnem robu upodobljen proti tej figuri usmerjen sprevod petnajstih moških in ženske. O sponi se je vedelo, da sodi med tiste najdbe s kranjskih najdišč, ki jih je vojvodinja Mecklenburška poklonila cesarju Wilhelmu in ki so leta 1918 kot njegovo posojilo prišle v berlinski muzej (Dobiat 1982, 11 s). Njeno točno najdišče ni bilo znano. Najprej sta jo objavila Wolfgang Lucke in Otto-Herman Frey (Lucke, Frey 1962, 71, kat. št. 20, t. 33), pozneje pa še Frauke Geupel (Geupel 1972, 203 s, sl. 1). Weiss je na podlagi arhivskih dokumentov ugotovil, da je bila spona med prazgodovinskimi najdbami, ki jih je cesar oddal muzeju v restavriranje 21. oktobra 1913 (Weiss 1993, 181; Weiss 1996, 44, op. 20). Spona je bila ob prihodu v muzej opremljena z oznako "Šentvid, Grob s kamnitimi ploščami 30, 14. april 1913" (*ib., sl. 3, desni stolpec spodaj*). Ker je bil 14. aprila 1913 odprt grob z oklepom, ki je bil pokrit s kamnitimi ploščami in označen s številko 30, je Weiss iz tega sklepal, da je spona nedvomno iz tega groba.

Grob z oklepom, ki ga je pri Stični izkopala vojvodinja Mecklenburška, in druge grobove z oklepom z območja jugovzhodnih Alp je Weiss datiral v čas okrog 600 pr. Kr. (Weiss 1993, 185), pasno spono pa uvrstil med najstarejše v situlskem slogu okrašene predmete iz Slovenije (*ib., 184*).

Teržanova je v svoji objavi, ki sem jo omenil na začetku članka, Weissovo predpostavko, da v grob z oklepom iz Stične sodi tudi okrašena pasna spona, označila kot napačno predvsem iz dveh razlogov (Teržan 2006, 263 s).⁵

⁵ Teržanova je svoje nestrinjanje z Weissovo uvrstitvijo pasne spona v grob z oklepom in z njeno datacijo v čas okrog leta 600 pr. n. št. izrazila dvakrat že pred letom 2006: Teržan 1997, 665, op. 44; Teržan 2001, 210, op. 15. Dodelitev pasne spona grobu z oklepom je kot nevzdržno označila tudi Alexandrine Eibner (2000, 138, op. 9), ni pa je sprejel niti Peter Turk, ki je sicer pasno spono datiral na konec 6. in v 5. stoletje pr. n. št. (Turk 2005b, 63, kat. št. 52).

Goldberg je v zapiskih izrecno omenil, da v grobu razen oklepa, suličnih osti, gumbov in keramičnih posod ni bilo drugih pridatkov. Poleg tega je spona po njenem mnenju precej mlajša od oklepa in ostalih pridatkov v grobu, saj se stilno uvršča v čas certoškega in zgodnjega negovskega horizonta.

Ker pa je v dveh dopisih, ki ju hrani arhiv berlinskega muzeja (v dopisu z dne 27. oziroma 30. oktobra in v dopisu z dne 21. novembra 1913), navedeno, da spona izvira iz groba s kamnitimi ploščami 30 (Steinplattengrab 30), je Teržanova menila, da je spona pripadala nekemu drugemu grobu, ki je bil označen podobno kot grob z oklepom. V poštevi naj bi prišel le grob 30 iz gomile 55 oziroma VI, med pridatki katerega je navedena tudi pasna spona (*ib., 264*).

Po Goldbergovem opisu ta grob sicer ni bil pokrit s kamnitimi ploščami (Wells 1981, 80). Ker pa je bilo v gomili VI kar 13 od skupno 32 grobov prekritih s kamnitimi ploščami, po čemer se je ta gomila razlikovala od vseh drugih, ki jih je pri Stični raziskala vojvodinja Mecklenburška (Mahr 1934, 115, kat. št. 132), po Teržanovi skoraj ni dvoma, da je bil tudi grob 30 prekrit s kamnitimi ploščami, čeprav jih Goldberg ni omenil (Teržan 2006, 267). Zato je pasno spono z upodobljenim sprevodom pripisala temu grobu (*ib., 266–268, sl. 71*). Grob je po Goldbergovih zapiskih vseboval fragmentirano dvogrebenasto čelado, v njej in okrog nje železne odlomke, ki naj bi bili ostanki štita ali konjske opreme, slabo ohranjeno pasno spono in odlomek sulične osti (Wells 1981, 80). Na fotografiji bloka, ki je bil dvignjen iz groba, sta vidni čelada in okrogla falera konjske opreme z dvema ušescema (*ib., 212, sl. 160*).

GROBNA CELOTA PASNE SPONE Z IZJEMNO FIGURALNO UPODOBITVIJO OSTAJA NEZNANA

Kot kaže, pasna spona s figuralnim sprevodom ni bila najdena niti v grobu 30 gomile IV, kot je domneval Weiss, niti v grobu 30 gomile VI, kot domneva Teržanova.

Proti Weissovi predpostavki govorita, kot je navedla že Teržanova (2006, 264), izrecna navedba Goldberga, da v grobu z oklepom ni bilo drugih najdb razen naštetih, med katerimi pa ni pasne spona, in pa dejstvo, da je spona po slogu upodobitve precej mlajša od oklepa in ostalih pridatkov v grobu. To pa pomeni, da je listek z oznako "St. Veit, Steinplattengrab 30, 14. April 1913", ki je bil priložen pasni sponi ali nalepljen nanjo (Weiss 1993, 181; Weiss 1996, 44, sl. 3), vseboval napačne podatke. Listek s tako vsebino se je nedvomno nanašal na grob z oklepom iz gomile IV. Priložen bi bil lahko edino oklepu ali kernosu, ki sta bila v pošiljki izkopani vojvodinje Mecklenburške iz Kranjske, ki jo je cesarju Wilhelmu na ladjo v Hamburgu pripeljal njen tajnik Goldberg že junija 1913 (Gabrovec 1978, 130; Weiss 1993, 176, op. 19 in 20). Kdo in iz kakšnih razlogov ga je priložil pasni sponi, ostaja neznan.

Iz več razlogov je jasno, da spona ne izvira niti iz groba 30 gomile VI. Čeprav je bilo s kamnitimi ploščami pokritih 13 grobov (Mahr 1934, 115, kat. št. 132), to je skoraj polovica grobov te gomile, pa nikakor ni verjetno, da bi bil Goldberg prav pri tem grobu, pri katerem je tako kot pri drugih navedel velikost in globino, v kateri je bil odkrit, pozabil omeniti kamnite plošče. Iz opisov, ki jih je

objavil Wells, izhaja, da so bili s ploščami pokriti grobovi 3, 6, 9, 10, 12, 13, 14, 15, 19, 22, 23, 24 in 26 (Wells 1981, 72–79). Če bi bil na enak način pokrit tudi grob 30, bi bilo takih grobov 14. Poleg tega je bilo na sponi s sprevedom že pred restavriranjem mogoče prepoznati živalsko in človeške figure, kar pomeni, da je bila razmeroma dobro ohranjena (Weiss 1993, 181). Grob 30 gomile VI pa je po Goldbergovih podatkih (Wells 1981, 80) vseboval slabo ohranjeno pasno spono, o kateri niti ne vemo, ali je bila železna ali bronasta. Teržanova ni omenila, da je bil na listku, ki je bil priložen okrašen sponi ali prilepljen nanjo, naveden tudi datum 14. april 1913.⁶ Tega dne odkriti Steinplattengrab 30 pa je zanesljivo grob 30 gomile IV, to je grob z oklepom, ne pa grob 30 gomile VI.

Še iz enega razloga je nemogoče, da bi okrašena pasna spona izvirala iz groba 30 gomile VI. Gomilo so začeli izkopavati 10. novembra 1913, izkopavanje pa je bilo končano 15. decembra (Wells 1981, 72). Glede na to, da je imela 32 grobov, je bil grob 30 izkopan med zadnjimi, torej zelo verjetno že decembra. Zgoraj omenjeni arhivski dokumenti v berlinskem muzeju pa dokazujejo, da je bila pasna spona v Berlinu že v drugi polovici oktobra 1913, to je prej, kot so gomilo VI začeli izkopavati. Iz arhivskih dokumentov, na katere je pred nekaj leti opozorila Gloria Polizzotti Greis, je mogoče razbrati celo, katerega dne jo je cesar dobil (Polizzotti Greis 2006, 42–44, op. 26 in 27). Oktobra 1913 mu je vojvodinja poslala novo pošiljko izkopanin, tokrat po švedskem arheologu Oscarju Monteliusu, ki je pred tem obiskal njena izkopavanja v Stični. S cesarjem sta se srečala v Bonnu 16. oktobra. Kot je razvidno iz telegrama, ki ga je vojvodinja tega dne poslala Monteliusu, in iz Monteliusovega pisma, ki ji ga je napisal takoj po obisku pri cesarju, je bila med najdbami tudi pasna spona, okrašena z edinstvenim prizorom. Za cesarja je bila posebno dragocena. Menil je, da na njej upodobljena žival prej predstavlja boga kot pa votivni dar. V restavriranje jo je predal, kot navaja Weiss, že čez nekaj dni, 21. oktobra 1913 (Weiss 1993, 181).

BRONASTI GUMBI

Bronasti gumbi iz groba z oklepom

Po zapiskih tajnika Goldberga je grob z oklepom vseboval nekaj okroglih gumbov ("einige runde Knöpfe", Weiss 1993, 177, op. 27; Teržan 2006, 264). Gumb, ki jih je grobu pripisal Mahr leta 1933, pa je kar 67 (Mahr 1934, 113, kat. št. 128, "Gr. 30: sixty-seven bronze buttons with loops"; sl. 3: b). V vseh štirih dosedanjih objavah groba z oklepom so risbe istih šestih primerkov (Gabrovec 1978, 143, sl. 7: 3,4; Wells 1981, 62, sl. 85: l,m; Weiss 1993, 177, sl. 15: 3; Teržan 2006, 265, t. 208: 3,4; sl. 1: 2,3; 4: 3/3,4). Trije od njih so enako veliki in imajo na sredini zunanji strani izboklino (sl. 1: 3), trije pa so različno veliki in

niso okrašeni (sl. 1: 2). Iz Wellsovega opisa, ki se nanaša na vseh 67 gumbov, izhaja, da so vsi kalotasti in da imajo na zadnji strani zanko. Po velikosti so različni, vendar jih ima večina premer 1,6 do 1,7 cm. Več kot polovica jih ima na sredini majhno izboklino, ki je sodeč po preseku enega gumba polna.

Gabrovec, Wells in Teržanova se z njimi niso posebej ukvarjali. Weiss jih je sicer omenil, podrobnejše tipološke in kronološke opredelitve pa se tudi on ni lotil (Weiss 1993, 184, sl. 15: 3). Navedel je le, da njihova namembnost ni določena in da so malo izpovedni, ker njihova lega in razporeditev v grobu nista bili v zadostni meri dokumentirani.

Od gumbov, pripisanih grobu z oklepom, so preprosti kalotasti gumbi z zanko (sl. 1: 2) res malo izpovedni, saj se v različnih kulturnih okoljih pojavljajo v žarnogrobiščni, starejši in mlajši železni dobi (prim. npr. Sakara Sučević 2004, 34, bronasti kalotasti gumbi vrste 1; Blečić 2003; Šribar 1974, 321, št. 23, t. 3: 10). Kot bomo videli, pa ni zanemarljivo dejstvo, da so različno veliki. Precej drugače pa je z gumbi, ki imajo na sredini zgornje strani majhno polno izboklino in na spodnji strani večinoma široko zanko (sl. 1: 3).

Bronasti kalotasti gumbi z izboklino in zanko vrste 2 po Sakari Sučević

Maša Sakara Sučević je v svoji obravnavi gradiva s Kaštelirja pri Novi vasi v Istri gumbe z izboklino na vrhu zgornjega dela kalote in s široko zanko opredelila kot vrsto 2 bronastih kalotastih gumbov (Sakara Sučević 2004, 34). Ta vrsta naj bi predstavljala najmlajšo različico teh gumbov, ki naj bi se prvič pojavila v mlajšem halštatskem obdobju in trajala še v latensko obdobje (ib., 35). Pregled gumbov, ki jih je Sakara Sučević uvrstila v vrsto 2, je pokazal, da se med seboj precej razlikujejo in da nekateri od njih niti ne sodijo vanjo. Gumb iz groba 110 na halštatskem grobišču na Križni gori nad Ložem (Urleb 1974, 58, t. 22: 4) ni kalotast in ima visoko polno izboklino ter razmeroma ozko zanko. Dva gumba iz Šmihela pod Nanosom (Guštin 1979, 46, t. 68: 33 a in c) in eden iz groba Sz 1484 z Mosta na Soči (Teržan, Trampuž 1973, t. 16: 12; Teržan, Lo Schiavo, Trampuž-Orel 1984–1985, 245, t. 137: 25) sploh nimajo izbokline, ampak sploščen vrh. Njihove zanke so oglate. Pri gumbih iz groba Benvenuti 278 iz Este je izboklina votla, namesto zanke pa imajo diametralno razporejeni luknjici ob robovih (Frey 1969, 15, sl. 3: 5).

Od gumbov, ki jih je vrsti 2 prištela Sakara Sučević, imajo tako kot večina gumbov iz stiškega groba z oklepom (sl. 1: 3) polno izboklino in bolj ali manj široko zanko samo en gumb s Kaštelirja pri Novi vasi (Sakara Sučević 2004, 34, sl. 202; sl. 5: 4), gumbi iz Velega Mišince pri Kastvu blizu Reke (Guštin 1987, sl. 7: 7 in 8: 3; sl. 6: 11,12) in gumbi iz groba 52 iz liškega Prozora (Drechsler-Bižić 1972–1973, 37, t. 28: 14; sl. 6: 7). Gumba iz Nezakcija (Mihovilić 2001, 233, t. 76: 47; sl. 5: 5,6) sta nekoliko drugačna. Polna izboklina trapezastega preseka je zelo visoka, zanka v obliki črke V pa zelo ozka. Ozko zanko ima tudi 15 gumbov z nizko izboklino z Grobišča pri Grobniku (Blečić 2004, 77, t. 8: 5.1.11), vendar je ta oglata.

⁶ Napačni podatki na tem listku so bili očitno povzeti v prej omenjenih dopisih v arhivu berlinskega muzeja z dne 27. oziroma 30. oktobra in z dne 21. novembra 1913, ki navajata, da je bila spona najdena v grobu s kamnitimi ploščami št. 30.

Kalotasti gumbi vrste Vinica

(seznam 1 in sl. 13)

Za navadno bronaste, izjemoma pa tudi železne kalotaste gube s polno izboklino na sredini zunanje strani in z večinoma široko zanko na spodnji strani predlagam ime "kalotasti gumbi vrste Vinica". Poleg gumbov iz Nove vasi in Nezakcija v Istri, iz Kastva in iz groba 52 iz Prozora sodi v to vrsto še nekaj gumbov iz Ribiča v dolini Une (sl. 5: 10,11) in z otoka Krka (sl. 5: 7–9), dalje številni gumbi z Grobnika blizu Reke (sl. 6: 14–16) ter štirje gumbi iz groba 22 latenske nekropole na Pungartu v Metliki (sl. 6: 5). V grobovih starejše in mlajše železne dobe na Dolenjskem takih gumbov niso našli. Edina izjema naj bi bili gumbi iz dveh gomil, ki ju je v Stični izkopala vojvodinja Mecklenburška, in sicer gumbi iz groba z oklepom iz gomile 52 oziroma IV (sl. 1: 3; 6: 1) in med posamičnimi najdbami iz gomile 55 oziroma VI (sl. 5: 1).

Poleg tega je gube te vrste vsebovalo vsaj 12 grobov grobišča, ki ga je vojvodinja Mecklenburška raziskala v Stražnem dolu blizu Goleka pri Vinici (Dular 1985, 106 s, sl. 103 in 126).⁷ Odkrila je okrog 350 planih grobov (Polizzotti Greis 2006, 26). Veliko večino njihovih pridakov hrani zdaj Muzej Peabody pri Harvardski univerzi, vendar so skoraj v celoti neobjavljeni (Mahr 1934, 47–56, 85–109, kat. št. 49–121; Polizzotti Greis 2006, 25–28 in 55, t. 2; 5–9), njihove fotografije pa si je mogoče ogledati na spletni strani Muzeja Peabody. Napredno iskanje po muzejskih zbirkah (<http://140.247.102.177/col/advanced.cfm>)⁸ omogoča iskanje po štirih podatkih hkrati. Z iskanjem po kraju Vinica (podatek WHERE) in predmetu gumb (button, podatek WHAT) pridemo do povezave do 72 fotografij gumbov. Na fotografijah je mogoče prepoznati številne kalotaste gube vrste Vinica.

Prisotnost gumbov vrste Vinica v dveh halštatskih gomilah iz Stične bi nakazovala, da so se pojavili že v halštatski dobi, vendar kot bomo videli, gumbi, pripisani stiškiška gomilama, sploh niso iz Stične! Ker se je izkazalo, da nekatere domnevne grobne celote z grobišča Veli Mišinac pri Kastvu to niso (Blečić 2002, 79), in ker grobne celote z Goleka pri Vinici niso niti objavljene niti zanesljive, so za datacijo gumbov vrste Vinica tako na voljo samo grob 1/1979 iz Kastva, grob 52 iz Prozora, grob 2/1987 z Grobnika in grob 22 s Pungarta v Metliki.

Vendar si tudi s prvim od teh štirih grobov, z grobom iz Kastva, ne moremo kaj prida pomagati. V njem je bil glede na antropološko analizo pokopan odrasel moški. Po Blečićevi so bili v grob pridani slabo ohranjen železen nož in štirje gumbi vrste Vinica (ib., 85, 98 s, št. 10.8; 100, št. 12, t. 1). Groba na podlagi noža ni mogoče natančneje datirati. Blečićeva ga je kljub temu pripisala stopnji LT C1 po srednjeevropski kronologiji zaradi verižnega pektoral, ki je bil odkrit v bližini, vendar zunaj groba (ib., 85, sl. 5). Tudi sicer je povezava štirih gumbov z moškim okostjem zelo vprašljiva. Kot je razvidno iz tlorisa, v nasprotju s

trditvijo Blečićeve ne drži, da so bili v grob pridani vsi štirje gumbi, ampak sta v grobni jami ležala samo dva. Druga dva sta se nahajala zunaj groba med kostmi, ki so po Šlausu pripadale odraslemu oslu in kravi ter še dvema osebam (ib.)!

Pač pa je zanesljiva grobna celota ženskega groba 52 iz Prozora, ki je poleg okostja vseboval razmeroma bogate prdatke. Poleg štirih bronastih fibul in 114 bronastih kalotastih gumbov (preprostih in vrste Vinica), ki so bili prišiti na usnjen pas (sl. 6: 7–10), so v njem našli številne steklene in jantarne jagode (Drechsler-Bižić 1972–1973, 37, t. 27–28; Bakarić 1993). Drechsler-Bižićeva je sprva menila, da bi grob zaradi dveh fibul s po dvema peresovinama in fibule s čolničastim lokom lahko pripadal stopnji LT D (Drechsler-Bižić 1972–1973, 20). Pozneje je datacijo spremenila. Grob je postavila v stopnjo 6 japonske skupine, ki ustreza stopnji LT C po srednjeevropski kronologiji oziroma 3.–2. stoletju pr. n. št. (Drechsler-Bižić 1987, 411 in 414). Lidije Bakarić nova datacija groba v srednjo latensko dobo očitno ni prepričala, ker ga je datirala v 1. stoletje pr. n. št. (Bakarić 1993, 114, kat. št. 96). Je pa spremenjeno datacijo prevzela Sakara Sučević (2004, 35): "Grob lahko na podlagi ... datiramo v japonsko šesto stopnjo, 3. stol. pr. n. št." Aleksandar Palavestra ga je v svoji knjigi o prazgodovinskem jantaru prvič datiral v čas od 300 do 1 pr. n. št. (Palavestra 1993, 82 in 84), drugič pa v stopnjo LT C2 (ib., kronološka tabela na str. 274).

Prva datacija Drechsler-Bižičeve v poznolatsko dobo je bila utemeljena, saj jo je podkrepila z ugotovitvijo, da so bile fibule, ki so primerljive fibulama z dvema peresovinama in fibuli s čolničastim lokom v grobu 52, najdene v grobnih celotah z Jezerin in iz Ribiča, ki jih je Marić pripisal svoji stopnji Vb, in v zakladni najdbi iz Ličkega Ribnika (Drechsler-Bižić 1972–1973, 20). Fibule s čolničastim lokom, kakršnih ena je bila v grobu 52 (ib., 37, t. 27: 8), se res pojavljajo v izrazito poznih grobovih nekropol Jezerine in Ribič (Marić 1968, 34, t. 5: 6; 16: 20; 17: 12,19,22,23, 31; 18: 29,30). Nekateri od njih vsebujejo fibule vrst Jezerine in Alezija, značilne za stopnjo LT D2 po srednjeevropski kronologiji (ib., t. 5: 7; 16: 21; 18: 31; Božič 2008, 145, tab. 5), najmlajši grob pa sodi zaradi močno profiliranih fibul že v zgodnjecesarstvo dobo (Marić 1968, t. 17: 29–34). V nekaterih od teh grobov so našli tudi fibule z dvema peresovinama in jagodo na loku (ib., t. 5: 3; 16: 22,28; 18: 25,26) ter jantarne jagode vrste 10 po Palavestri (ib., t. 5: 8,12; 16: 29; 18: 34; Palavestra 1993, tipološka tabla 1 na str. 33), torej oblike, ki jih je vseboval tudi grob 52 iz Prozora (Drechsler-Bižić 1972–1973, t. 27: 1,4–7; Palavestra 1993, 82, 300–1 pr. n. št.).

Gumbi vrste Vinica so torej glede na grob 52 iz Prozora poznolatski. Ker gre za pokop ženske, so sodili k ženski noši, in sicer so bili skupaj s preprostimi kalotastimi gumbi prišiti na pas. Omenil sem že, da se je v grobu ohranilo skupno 114 gumbov obeh vrst. Njihova velikost je zelo različna, saj imajo največji skoraj štirikrat večji premer kot najmanjši (sl. 6: 7–10). Zelo verjetno so deli podobnih pasov tudi številni različno veliki kalotasti gumbi (preprosti in vrste Vinica) iz Kastva in z Grobnika (Blečić 2002, t. 10 in 11; Blečić 2004, t. 7 in 8 – sl. 6: 11–13 in 14–20).

S kalotastimi gumbi dveh velikosti in dveh vrst je bil okovan tudi 4 cm širok pas, ki je ležal v okostnem grobu

⁷ Poznavanje najdb s planega poznohalštatsko-latenskega grobišča blizu Goleka pri Vinici mi je omogočil Michael Geselowitz, ki mi je pred mnogimi leti poslal fotokopije njihovih risb.

⁸ Zadnji dostop 22. 9. 2009.

2/1987 na Grobniku (Cetinić 1996, 195, sl. 11; Blečić 2003; Blečić 2004, 57 s, 63, 91 s, sl. 17, t. 1: 1–2). Dva niza večjih gumbov sta bila prišita ob robovih, na vmesnem pasu pa so bili prišiti manjši gumbi, razporejeni v obliki cvetov s petimi venčnimi listi. Blečićeva gumbov ni podrobno opisala, ampak je samo navedla, da gre za kalotaste oziroma polkalotaste gumbe (ib., 58, 63, 2. Pojasna pločica, 91). Tudi risb gumbov ni objavila. Fotografija, ki prikazuje gumbe in ploščici (ib., sl. 17), je sicer majhna, vendar se na njej kljub temu vidi, da imajo večji gumbi, prišiti ob robovih, na sredini izboklino. Gre torej za kalotaste gumbe vrste Vinica, ki jih je bilo v sondi 3, v kateri je bil odkrit grob 2/1987, najdenih še 57 (ib., 75, št. 5.1.1, 5.1.2 in 5.1.3, t. 7: 5.1.1 in 5.1.2). Pas se je spenjal s pravokotno ulito spono vrste Bela Cerkev (ib., sl. 17 in t. 1: grob 2/1987, št. 2), ki omogoča datacijo groba v stopnjo Mokronog IIIa oziroma LT D1 (Božič 1999, 211). Na pasu je bil tudi pravokoten ovok, ki je bil nanj pritrjen na štirih mestih in je bil ulit v istem kalupu kot spona.

V grobu je bil najden tudi odlomek jantarne jagode, najverjetneje ostanek ogrlice. Okostje je bilo zelo slabo ohranjeno. Po antropološki analizi naj bi šlo za moškega (Blečić 2004, 58), vendar je to zelo malo verjetno.

Gumbe vrste Vinica je vseboval tudi grob 22 s Pungarta v Metliki. V tem žganem ženskem grobu je bilo poleg para srebrnih fibul srednjelatenske sheme z dolgo peresovino (Šribar 1974, 321, t. 3: 3,4; sl. 7: 1,2) še veliko gumbov, in sicer štirje večji s premerom pribl. 12 mm in okoli sto manjših s premerom 4 mm (ib., t. 3: 10). Večji gumbi imajo izboklino, ki je na risbi v Šribarjevem članku narisana kot votla, čeprav je polna (sl. 6: 5,6).⁹

Fibuli imata tričleno objemko in po dve tričleni in spodaj ravni odebelitvi na zapognjeni nogi (Božič 1983, 119, sl. 37). Ena leži pred objemko, druga pa pred lokom. Zelo podobne srebrne fibule, najdene predvsem v Mihozem (Aubelj 1999, sl. na str. 172) in tudi na Strmcu nad Belo Cerkvijo (Stare 1973, 41, št. 879 in 880, t. 47: 2,3; sl. 7: 3,4), so značilnost ženske noše stopnje Mokronog IIIa mokronoške skupine (Božič 1999, 210; Božič 2008, 56 s), ki ustreza stopnji LT D1 po srednjeevropski kronologiji. Razlika med njimi in fibulama iz Metlike je le v tem, da pri metliških lok ni ploščat in peresovina ni tako izrazito dolga. Fibuli torej nakazujejo, da je grob 22 iz Metlike sočasen grobu 2/1987 z Grobnika. Oba sta vsebovala pas, okovan z velikimi kalotastimi gumbi vrste Vinica in majhnimi preprostimi kalotastimi gumbi.

Gumbi vrste Vinica imajo, če ne upoštevamo primerkov iz Stične, omejeno razprostranjenost od Istre na zahodu do doline Une na vzhodu (sl. 13). Tisti, ki so jih našli v grobu 22 iz Metlike, v grobu 2/1987 z Grobnika¹⁰ in v grobu 52 iz Prozora, so bili skupaj s preprostimi kalotastimi gumbi prišiti na ženske pasove. To velja zelo verjetno tudi za gumbe iz grobov na Goleku pri Vinici in številne gumbe brez grobnih celot iz Kastva in z Grobnika. Glede na starost omenjenih treh grobov so poznolatenški. Zato ni verjetno, da gumb, pripisan grobu 3 iz Baške (sl. 5: 8), res sodi v ta grob (Lo Schiavo 1970, 426, t. 24: 14). Grobova

iz Ribiča sta že zgodnjerimska in sta tako kot grob 3 iz Baške vsebovala samo po en gumb vrste Vinica. Gumba je že Marić prištel med starejše oblike, ki se še pojavljajo v nekaterih grobovih stopnje VI v Pounju (Marić 1968, 37, t. 20: 20; 22: 3; sl. 5: 10,11).

NOVA REKONSTRUKCIJA GROBA Z OKLEPOM IZ STIČNE

Povedal sem že, da gumbov vrste Vinica na Dolenjskem razen v Stični ni. Gumbi te vrste, pripisani leta 1913 izkopenemu grobu z oklepom (sl. 1: 3; 6: 1), so bili glede na navedene primerjave skupaj s preprostimi kalotastimi gumbi treh velikosti (sl. 1: 2; 6: 2–4) prišiti na poznolatenški ženski pas. Zato je seveda izključeno, da bi bili res iz tega groba. Po Goldbergovih zapiskih je grob sicer vseboval nekaj okroglih gumbov, ki pa se niso ohranili ali pa so bili dodani nekemu drugemu grobu iz Mecklenburške zbirke.

Gumbi so dokaz, da je sestava groba z oklepom, kot jo prinašajo dosedanje objave, napačna. Namesto pravih gumbov so bili grobu pripisani gumbi, ki niso samo iz drugega groba, ampak celo z drugega najdišča. Ker so poznolatenški, zagotovo niso iz Stične, saj stiške gomile niso vsebovale naknadnih pokopov latenske dobe (Gabrovec 1994a, 40). Tudi z Magdalenske gore niso, ker v tamkajšnjih poznolatenških grobovih takih gumbov niso našli. Lahko so samo z Goleka pri Vinici, kjer so gumbe vrste Vinica, ki jih praviloma spremljajo preprosti kalotasti gumbi, našli v najmanj 12 grobovih. Z istega najdišča so gotovo tudi gumbi vrste Vinica, pomešani med posamične najdbe gomile 55 oziroma VI iz Stične (seznam 1, št. 2; sl. 5: 1). Tudi pri teh gre očitno za gumbe, ki so bili skupaj s preprostimi kalotastimi gumbi prišiti na ženski pas, saj so med posamičnimi najdbami gomile VI poleg njih tudi preprosti gumbi z zanko in gladko kaloto treh velikosti (Wells 1981, 80, posamične najdbe gomile VI, 213, sl. 161: a, četrta vrsta), kar natanko ustreza kalotastim gumbom, pripisanim grobu 30 gomile IV (sl. 6: 1–4), in tistim iz groba 52 iz Prozora (sl. 6: 7–10).

Če v grobu z oklepom niso bili najdeni kalotasti gumbi z zanko, lahko to velja tudi za druge pridane. Zanesljivo so iz njega le predmeti, ki jih lahko prepoznamo iz opisa oziroma so vidni na fotografijah. Po Mahrovem prepisu Goldbergovih zapiskov (sl. 3) so bile v grobu tri keramične posode, dve od teh zelo lepo izdelani in zelo redke oblike. Prva, ki jo je Mahr leta 1933 označil s (c), je imela po Goldbergu na zgornjem delu 4 posodice ("am oberen Rand der Urne sind 4 kl. Urnen"). Gre torej za kernos (sl. 4: 2; 8: 2), ki je viden tudi na fotografiji.¹¹

¹¹ Vojvodinja Mecklenburška je oklep in kernos že junija 1913, to je dva meseca po odkritju groba z oklepom, podarila cesarju Wilhelmu II. (Weiss 1993, 175 ss, op. 19 in 24). Kernos je grobu prvi pripisal Gabrovec na podlagi fotografije odprtega groba, na kateri sta vidna oklep in kernos (Gabrovec 1978, 142 s, sl. 5; sl. 4: 2), za njim so to storili tudi Wells, Weiss in nazadnje Teržanova (sl. 2: 3). Do iste ugotovitve pa bi bil lahko že veliko prej prišel zlasti kateri od prazgodovinarjev Muzeja za prazgodovino

⁹ Podatek Janeza Dularja.

¹⁰ Kot sem že omenil, je zelo malo verjetno, da bi bil grob 2/1987 z Grobnika moški.

V Zürichu ga ni bilo, saj je bil že junija 1913 poklonjen nemškemu cesarju. Skladno z Goldbergovim podatkom o treh posodah je Mahr leta 1933 grobu z oklepom poleg kernosa pripisal še dve posodi. Druga, ki jo je označil z (d), je bila majhna ("kl. Gefäß"), tretja, ki jo je označil z (e), pa večja ("größeres Gefäß"). Z majhno posodo je lahko označil samo lonček (sl. 8: 4),¹² v katerem je bil očitno listek, ki je zdaj nalepljen na prvi kartotečni list (sl. 3). Na njem piše: "Kl Urne aus Grab 30. (d) Gr Gomila St Veit 15 April 1913." Z večjo posodo pa je Mahr lahko označil samo veliki lonec z nagubanim trebuhom (sl. 4: 3/11), ki grobu zagotovo ni bil dodan šele v Muzeju Peabody, saj ne ustreza Hencknovim opisom (sl. 3: g–j).

Po objavah Wellsa in Weissa naj bi h grobu poleg kernosa, lončka in lonca z nagubanim trebuhom sodili tudi deli treh posod, manjšega ciborija z grafitnim premazom (sl. 2: 5) in dveh pokrovov (sl. 2: 4), ki jih je grobu z oklepom dodal šele Hencken (sl. 3: g–j). Teržanova je lonec spremenila v ciborij (sl. 2: 2) in dodala še en manjši ciborij (Teržan 2006, 266, t. 208: 7; sl. 2: 6). Rekonstruirala ga je iz dveh pri Gabrovcu objavljenih odlomkov (Gabrovec 1978, sl. 7: 1,8; sl. 4: 3/1,8). Prvega od njiju Wells nima, drugega pa ni opredelil tako kot Gabrovec za ustje, ampak za spodnji rob noge (Wells 1981, sl. 85: i).

Grobu z oklepom lahko poleg kernosa (sl. 8: 2) zanesljivo pripišemo tudi lonček (sl. 8: 4), v katerem je bil očitno listek, ki je zdaj nalepljen na prvem kartotečnem listu. Ker je lonček preproste oblike in neokrašen, se Goldbergov podatek, da sta dve od treh posod zelo lepo izdelani in zelo redke oblike, nanaša na kernos in na tretjo posodo. Oznaki "zelo lepo izdelan in zelo redke oblike", ki pa je za zanesljivo določitev še vedno presplošna, sicer dobro ustreza ciborij z nagubanim trebuhom (Teržan 2006, 266, op. 8, t. 208: 10; sl. 8: 5), ki ga je grobu z oklepom pripisal že Mahr leta 1933. Vendar pa je glede na druge zamenjave možno, da je tudi ta posoda dejansko iz kakega drugega groba. Isto velja za sulični osti (sl. 8: 6,7): lahko sta iz

in zgodnjo zgodovino v Berlinu, kjer sta bila od leta 1922 dalje oklep in kernos vključena na stalno razstavo (Weiss 1993, 177, op. 24; Weiss 1999, 64). Pri pazljivem branju dražbenega kataloga, ki je izšel leta 1934 v New Yorku (prim. Weiss 1993, 182, op. 47; Weiss 1999, 66), bi bil namreč lahko ugotovil, da je Ferenc de Tompa iz Budimpešte v članku o gomilnem grobišču pri Stični (Mahr 1934, 59 s) omenil, kako je pokojna vojvodinja Mecklenburška predala bronasti oklep iz groba 30 gomile IV nekdanjemu nemškemu cesarju in na ta način razbila grobno celoto ("The whole grave in which this armor was found was thus split up"). V kataloškem delu dražbenega kataloga oklep iz groba 30 gomile IV ni omenjen, so pa v njem naštet drugi pridatki tega groba: 67 bronastih gumbov z zanko, dve železni sulični osti in trije značilni primerki keramike, med temi posoda s štirimi čašicami na zgornjem delu ("one with four little cups attached to the upper part of the vessel", ib., 113, kat. št. 128). Za morebitnega kupca je bil ta podatek zavajajoč, saj kernosa, ki je že leta 1913 prispel v Berlin, seveda ni bilo na dražbi.

¹² Teržanova (2006, 266, t. 208: 5) navaja, da je visok 6 cm. Glede na merilo 1:4 v Wellsovi objavi (Wells 1981, 176, sl. 85: j) je visok 8 cm.

groba z oklepom, lahko pa tudi iz kakega drugega groba. Ker je po Goldbergu grob z oklepom vseboval samo tri glinaste posode, od katerih smo lahko določili kernos in lonček, medtem ko je bila tretja zelo lepo izdelana in zelo redke oblike (morda ciborij z nagubanim trupom), iz njega zanesljivo niso deli dveh pokrovov in enega ali dveh ciborijev z grafitnim premazom, ki jih je grobu dodal šele Hencken.

Glede na to so bili v grobu z oklepom zanesljivo najdeni samo oklep, kernos in lonček ter nekaj okroglih gumbov, ki so zdaj izgubljeni ali neznano kje (sl. 8: 1–4), morda pa tudi ciborij z nagubanim trupom in sulični osti (sl. 8: 5–7). Zanesljivo pa mu ne pripadajo pokrova, eden oziroma dva manjša ciborija z grafitnim premazom in 67 kalotastih gumbov z zanko (vrste Vinica in preprostih) (sl. 2: 4–6; I: 2,3).

ZANESLJIVOST GROBNIH CELOT MECKLENBURŠKE ZBIRKE

Grobne celote iz Stične in z Magdalenske gore

V dosednji literaturi o Mecklenburški zbirki, ki poleg manjšega števila najdb z nekaterih drugih najdišč obsega zlasti najdbe iz Hallstatta, z Vač, iz halštatskih gomil na Magdalenski gori in pri Stični ter s planega halštatsko-latenskega grobišča na Goleku pri Vinici (Mahr 1934; Hencken 1978; Wells 1981; Dobiati 1982; Polizzotti Greis 2006), ni bilo dovolj poudarjeno dejstvo, da so objavljene grobne celote velikokrat napačne (prim. Weiss 1996), saj je gradivo pomešano. Kako je z grobnimi celotami z Vač, ni mogoče reči, ker še niso objavljene. V halštatske grobove iz Stične in z Magdalenske gore pa je zašlo precej najdb, ki nedvomno izvirajo z Goleka pri Vinici. To dejstvo doslej ni bilo tako očitno, ker velik del viniških najdb še ni bil objavljen. Najdbe viniškega značaja se pojavljajo samo v tistih grobovih z Magdalenske gore in iz Stične, ki jih je izkopala vojvodinja Mecklenburška in katerih gradivo se zdaj hrani v Muzeju Peabody, ne pa v grobovih s teh dveh najdišč, katerih pridatke hranita Narodni muzej v Ljubljani in Naravoslovni muzej na Dunaju (Tecco Hvala, Dular, Kocuvan 2004; Gabrovec et al. 2006), in seveda tudi ne v grobovih z drugih halštatskih najdišč na Dolenjskem.

Na tem mestu bi rad opozoril le na nekaj primerov. V nekaterih halštatskih grobovih z Magdalenske gore se pojavljajo v dvodelnem kalupu uliti obročki z izrastki, ki so v dražbenem katalogu Mecklenburške zbirke in v Hencknovi knjigi imenovani sončni obročki – "sun rings" (Mahr 1934, 80, kat. št. 25, grob 30, t. 7: 25; 82, kat. št. 34, grob 44, t. 1: 34; Hencken 1978, sl. 63: b; 127: d; 204: e; 265: d; 359: q; sl. 9: 1). Taki obročki so sicer znani samo z Goleka pri Vinici (Gabrovec 1966a, 179, št. 43, t. 20: 12,14–16,18; Lo Schiavo 1970, 469, št. 29, t. 37: 25; sl. 9: 2,3; 10), iz Podzemlja (Dular 1978, t. 14: 5) in iz naselbinskih plasti pri Sv. Duhu v Črnomlju (Božič 1992, 191, op. 10).¹³ Tudi

¹³ Po podatkih, ki mi jih je 25. maja 2009 poslal izkopavalec Phil Mason, je bil sončni obroček iz Črnomlja – gre za 2 kosa istega obročka – najden leta 1990 v stratigrafski enoti 160, to je v poznorimski plasti odpa-

latenskodobne igle v obliki pastirske palice, zanesljivo izpričane samo na Goleku pri Vinici (Gabrovec 1966a, t. 19: 1–9), v Podzemlju (Dular 1978, t. 15: 23; 16: 1–6; Božič 2001, 187, sl. 15; 18–20; 192, seznam 4) in Kastvu (Blečić 2002, 82 s, 92 s, kat. št. 2, sl. 4, t. 1: 2), so se znašle v dveh halštatskih grobovih iz Mecklenburške zbirke, izkopanih na Magdalenski gori (Hencken 1978, 24, grob 37, sl. 78: a) in v Stični (Wells 1981, 59, grob 19, sl. 73: a,b), pa celo med posamičnimi najdbami v samem Hallstattu (ib., 24, sl. 27: a).¹⁴ Očitno gre tudi v teh treh primerih za igle z Goleka pri Vinici, ki so bile dodane gradivu z drugih najdišč (Božič 2001, 197).

Jantarne jagode vrst 8d in 8e po Palavestri

Med neobjavljenim gradivom z Goleka pri Vinici je veliko jantarnih jagod, ki imajo poleg navpične luknjice na sredini še eno vodoravno tangencialno luknjico. Pri nekaterih je obod na mestih, kjer se luknjica konča, izjedeno. Palavestra (1993, 31, tipološka tabla 1) je take jagode označil kot vrsto 8d (z zaobljenim obodom) oziroma 8e (z izjednim obodom). Viniških primerkov ni poznal. Z njegove karte razprostranjenosti (ib., stran 187) izhajajo, da se take jagode pojavljajo samo v Liki (na najdiščih Kompolje in Prozor – Bakarić 2004, kat. št. 5.1; Bakarić 2008) in na nekropoli Jezerine v Pounju, na Magdalenski gori in v Stični (v halštatskih grobovih Mecklenburške zbirke) ter v latenskem grobu na Kapiteljski njivi v Novem mestu (Palavestra 1993, 174, vrsti 8d in 8e).

Jagoda vrste 8d iz razmeroma zgodnjega groba 139 v Kompolju (ib., 77, 750–650, 79, tip 8d), znana s starih Brunšmidovih izkopavanj, je po starosti povsem osamljena. Na nekropoli Jezerine so tovrstne jagode (glej grobove, našete ib., 99, tip 8d, in tudi grob 264) našli v grobovih faz II, IV, Va, Vb in VI po Mariću:

faza II: Jezerine 129 in 216 (Radimský 1895, 94 s in 112; Marić 1968, 17, op. 142 na str. 68)

faza IV: Jezerine 264, 318 in 520 (Radimský 1895, 123, sl. 306, 137 in 177 s; Marić 1968, 27, op. 221 na str. 73)

faza Va: Jezerine 325 (Radimský 1895, 138, sl. 378 na str. 130; Marić 1968, t. 4: 12; 32, op. 244 na str. 74; sl. 11: 2)

faza Vb: Jezerine 136b in 175 (Radimský 1895, 96 in 104; Marić 1968, 35, op. 272 in 274 na str. 75)

faza VI: Jezerine 68 (Radimský 1895, 81, sl. 127; Marić 1968, t. 6: 17; 38, op. 300 na str. 76).

Od dveh grobov iz faze II, ki naj bi po Mariću (1968, 40) trajala od 500 do 360 pr. n. št., skeletni grob 129 s

polkrožno ločno fibulo ni objavljen, grob 216 pa je tako kot grob 121a vseboval certoško fibulo vrste Xg po Teržanovi (Radimský 1895, 93, sl. 169; 112; Marić 1968, t. 2: 20 in tab. 3: 85; Teržan 1976, 334). Po Mariću (1968, 17) naj bi fibuli kazali na neposredne povezave z vzhodnoalpskim prostorom in naj bi imeli dobre primerjave samo med najdbami iz Šmihela pod Nanosom. Po Teržanovi (1976, 334, sl. 52) pa so fibule različice Xg razprostranjene v Posočju, na Notranjskem in Krasu, v zaledju Reke, na Dolenjskem, v Beli krajini in dolini Une. O dataciji Marićeve II. faze je menila, da nima izrazitih elementov, ki bi upravičili tako zgodnjo datacijo (ib., op. 164 na str. 421). Grobova 121a in 216 s fibulama različice Xg in grob 95 s fibulo vrste XII je postavila v prvi mladohalštatski horizont grobov v Jezerinah, ki se po njenem mnenju ni začel pred sredino 4. stol. (ib., 382).

Glede na datacijo grobov iz Jezerin, ki vsebujejo jantarne jagode vrste 8d po Palavestri, lahko trdimo, da so se te pojavile na koncu halštatske dobe, da so bile v rabi celotno latensko dobo in izjemoma tudi na začetku rimske. Jagode vrste 8e pa so, kot se zdi, latenskodobne, saj so bile na nekropoli Jezerine (glej grobove, našete v Palavestra 1993, 99, tip 8e, in tudi grobova 467 in 518) najdene samo v grobovih faz III, IV, Va in Vb po Mariću:

faza III: Jezerine 103 (Radimský 1895, 87, sl. 154; Marić 1968, 23, op. 193 na str. 72; sl. 12: 1)

faza IV: Jezerine 318, 515, 520 in 524 (Radimský 1895, 137, 176, sl. 570, 178; Marić 1968, 27, op. 221 in 222 na str. 73)

faza Va: Jezerine 308, 359 in 467 (Radimský 1895, 135, 145, sl. 415, 168, sl. 523; Marić 1968, t. 4: 28; 32, op. 244 in 245 na str. 74; sl. 12: 2)

faza Vb: Jezerine 518 (Radimský 1895, 177, sl. 575; Marić 1968, 35, op. 273 na str. 75).

Nekaj primerkov jantarnih jagod vrste 8e je bilo najdenih tudi v Prozoru (Palavestra 1993, 85, tip 8e), vendar niso datirani.

Kot že rečeno, vsebujejo jagode vrst 8d in 8e tudi halštatski grobovi z Magdalenske gore in iz Stične v Mecklenburški zbirki (Magdalenska gora: Hencken 1978, sl. 20: b; 75: a,b; 89: d; 98: a; 262: l,m; 365: c; Palavestra 1993, 174; Stična: Wells 1981, sl. 58: b; 78: a; 84: a; 96: a; 147: c; 150: g; 157: c; Palavestra 1993, 174; sl. 11: 1; 12: 3) ter latenski grob 35 gomile A na Kapiteljski njivi v Novem mestu (Knez 1986, 97, t. 48: 13).

Glede na to, da so bile jagode vrst 8d in 8e zanesljivo najdene samo v grobovih nekropole Jezerine v Pounju, datiranih od pozne halštatske do pozne latenske dobe, in izjemoma še v zgodnjerrimskih grobovih, dalje v Kompolju in Prozoru v Liki, v številnih grobovih z Goleka pri Vinici in v enem od latenskih grobov v Novem mestu, medtem ko jih v halštatskih grobovih na Dolenjskem z izjemo grobov z Magdalenske gore in iz Stične iz Mecklenburške zbirke ni bilo, je na dlani, da tudi tiste jagode, ki so bile objavljene kot deli halštatskih ogrlic z Magdalenske gore in iz Stične, niso od tam, ampak gre za viniško gradivo, ki je bilo zamešano med najdbe iz halštatskih grobov s teh dveh dolenskih najdišč. Tudi ogrlica, ki jo je objavila Polizzotti Greis in naj bi izvirala z Magdalenske gore, ne more biti od tam, ampak je lahko samo z Goleka pri Vinici (Polizzotti Greis 2006, 94 s, t. 19).

dnega materiala stožčaste oblike na severni, zunanji strani poznorimskega obrambnega stolpa pri cerkvi sv. Duha. Očitno gre za najdbe iz poznolatskih plasti, ki so bile poškodovane ob gradnji poznorimskodobne utrdbe na mestnem pomolu.

¹⁴ Wells igle ni prepoznal in je mislil, da sta njena odlomka verjetno eden ali dva ročaja bronaste posode. Igla po okrasu na eni strani glave in po spodnjem delu, ki je v preseku pravokoten in ima zapognjen konec, povsem ustreza tistim iglam v obliki pastirske palice iz Podzemlja, ki so dobro ohranjene (Dular 1978, t. 16: 2,4; Božič 2001, 187, sl. 15 in 19).

Grobne celote z Goleka pri Vinici

Niso pa pomešane samo grobne celote z Magdalenske gore in iz Stične, ampak tudi tiste z Goleka pri Vinici. Gotovo je tudi pri viniškem gradivu prihajalo do tega, da so bile najdbe iz določenega groba pripisane kakemu drugemu grobu. Poleg tega so bile nekaterim viniškim grobnim celotam dodane najdbe iz halštatskih gomil na Magdalenski gori in pri Stični. Dva primera sta zelo zgovorna.

Grob 97 z Goleka pri Vinici je po dražbenem katalogu Mecklenburške zbirke vseboval ostanke bronaste posode (Mahr 1934, 93, kat. št. 69).¹⁵ V resnici gre za dele krajcev sestavljene čelade,¹⁶ in sicer glede na okras natanko tiste, ki je bila odkrita v grobu 15 gomile V pri Stični (Gabrovec 1962–1963, 308, op. 65, t. 9: 2; Egg 1980, 246, sl. 3: 1; Wells 1981, 71, grob 15, sl. 125: f; Egg 1986, 167, kat. št. 105, sl. 115: 2, t. 49: b; Božič 1992, 191, op. 13 in 14). Iz istega viniškega groba naj bi bila tudi dva zaključka votle ovratnice v obliki živalske glave.¹⁷ Tudi za ta je komaj verjetno, da sta res z Goleka pri Vinici. Podobni zaključki se namreč pojavljajo predvsem na zahodu Slovenije, v Posočju (na Mostu na Soči, Teržan, Lo Schiavo, Trampuž-Orel 1984–1985, 30 s, št. 8, votla ovratnica, 368, grob 2337, št. 5, t. 246: C5; Mlinar 2009, 221, sl. 4: 3; 5), na Gorenjskem (v Mošnjah, ib., 221, op. 43) in Notranjskem (v Šmihelu pod Nanosom, Guštin 1979, 46, t. 65: 7). Na Dolenjskem sta znana dva zaključka ovratnice z Magdalenske gore (Tecco Hvala, Dular, Kocuvan 2004, 82, grob 1/1, št. 14, t. 127: 14; Mlinar 2009, 221, op. 39), bolj proti vzhodu pa niso bili najdeni. Še najverjetneje je torej, da sta tudi zaključka iz groba 97 na Goleku pri Vinici z Magdalenske gore, ni pa izključena niti možnost, da sta iz Stične tako kot deli sestavljene čelade v istem grobu.

Iz groba 222 na Goleku pri Vinici pa naj bi bil odlomek figurarno okrašene situle. Med zakovicami, ki spenjajo plašč, je okras petih križno razporejenih iztolčenih bunčic. V halštatskih grobovih v Beli krajini sicer niso našli nobenega predmeta, ki bi bil okrašen v situlskem slogu. Glede na okras sodi "viniški" odlomek zelo verjetno k situli iz groba 6-7-7a gomile V na Magdalenski gori (Hencken 1978, 30, sl. 111), kjer ustrezen odlomek manjka.

Sklep

Zgornje ugotovitve nas opozarjajo, da je treba grobne celote z Magdalenske gore, iz Stične in z Goleka pri Vinici v Mecklenburški zbirki obravnavati skrajno previdno. Kadar najdb ni mogoče zanesljivo prepoznati na podlagi podatkov v Goldbergovih zapiskih, skic ali fotografij (kot npr. kernos iz groba z oklepom, ki je viden na fotografiji in ga Goldberg opisuje kot keramično posodo s 4 posodi-

¹⁵ "69. Vinica, continued: graves 96, 97, 98a, and 98b. Comprising fragments of a rare bronze vessel (?) with hering-bone ornamentation, found in gr. 97. Unfortunately it was possible to preserve fragments only."

¹⁶ Spletni katalog. <http://140.247.102.177/col/longDisplay.cfm?ObjectKey=117004> [zadnji dostop 22. 9. 2009].

¹⁷ Spletni katalog. <http://140.247.102.177/col/longDisplay.cfm?ObjectKey=116417> [zadnji dostop 22. 9. 2009].

cami), pri nobeni ni trdnega jamstva, da je res iz groba, v katerega je uvrščena v objavi. Lahko je iz kakega drugega groba z istega najdišča ali pa celo z drugega najdišča. Da je prihajalo do številnih zamenjav, ni niti najmanj presenetljivo, če upoštevamo ugotovitve Janeza Dularja, kaj vse se je z najdbami Mecklenburške zbirke dogajalo od leta 1905 do leta 1933, ko so jo v Zürichu pripravljali za dražbo (Dular 2009). Najdbe viniškega značaja iz halštatskih grobov na Magdalenski gori in v Stični so nedvomno z Goleka pri Vinici.

Če se na koncu dotaknem še na začetku navedenega prepričanja Petra Wellsa, češ da so grobne celote gomile 52 oziroma IV po vojvodinji Mecklenburški iz Stične popolnoma zanesljive, moram žal ugotoviti, da je napačno. Dokaz za to so med drugim grob z oklepom (št. 30), grob z dvema iglama v obliki pastirske palice (št. 19 – Wells 1981, 59, sl. 73)¹⁸ in tisti grobovi iz te gomile, ki vsebujejo jantarne ogrlice, ki imajo v svoji sestavi tudi jagode vrst 8d in 8e (št. 4, 23, 29 in 41a). Manjša ciborija in pokrova (Teržan 2006, 266, št. 7–9; sl. 2: 4–6), pripisani grobu z oklepom, so iz kakega drugega stiškega groba, z Magdalenske gore ali celo s kakega drugega najdišča dolenjske halštatske kulture, na katerem je izkopavala vojvodinja Mecklenburška. Kalotasti gumbi (preprosti in vrste Vinica) iz istega groba (sl. 1: 2,3), igli v obliki pastirske palice iz groba 19 in jantarne jagode vrst 8d in 8e iz grobov 4 (sl. 11: 1), 23, 29 ter 41a pa so z grobišča v Stražnem dolu blizu Goleka pri Vinici v Beli krajini.¹⁹

SEZNAM 1 (sl. 13)

Kalotasti gumbi vrste Vinica²⁰

1. Metlika – Pungart, grob 22 (sl. 6: 5)

4 gumbi pr. približno 1,2 cm.

Šribar 1974, 321, grob št. 22, št. 23, t. 3: 10.

2. Golek pri Vinici – Stražni dol, grobovi 1, 3, 30, 34, 35, 43A, 78, 127, 145, 204, 215 in 277 ter posamične najdbe

¹⁸ Po mnenju Teržanove in Gabrovca je iz tega groba verjetno skledasta čelada, ki je prišla v berlinski muzej (Gabrovec et al. 2006, 262, t. 206).

¹⁹ Za dragocene podatke v zvezi z zgodovino Mecklenburške zbirke in posredovano literaturo se zahvaljujem sodelavcu Janezu Dularju. Za podatke o najdbah sem hvaležen Martini Blečić Kavur s Filozofske fakultete Univerze na Reki in Philu Masonu z območne enote Novo mesto Javnega zavoda RS za varstvo kulturne dediščine, pri pripravi slikovnega gradiva pa so mi ljubezno pomagali Polona Bitenc, Barbara Jerin, Ida Murgelj in Peter Turk iz Narodnega muzeja Slovenije v Ljubljani, Manfred Nawroth iz Muzeja za prazgodovino in zgodnjo zgodovino v Berlinu ter Patricia Kervick iz Muzeja Peabody pri Harvardski univerzi v Cambridgeu v Združenih državah Amerike." Toplo se zahvaljujem tudi Nini Crummy iz Colchestra za skrbno opravljeno lekturo prevoda.

²⁰ Kalotasti gumbi vrste Vinica so navadno bronasti, v Kastvu pa so poleg bronastih našli tudi 12 železnih. Na gumbе iz Baške in Garice na Krku, s Krka in iz Ribiča me je ljubezno opozorila Martina Blečić Kavur z Reke.

Gumbi iz grobov so neobjavljeni.

Najmanj 34 gumbov pr. večinoma 1,6 do 1,7 cm (pripisani grobu 30 gomile 52 iz Stične, *sl. I*: 3; 6: 1).

Wells 1981, 62, grob 30, 176, sl. 85: l.

Nekaj gumbov (pripisani posamičnim najdbam gomile 55 pri Stični, *sl. 5*: 1).

Wells 1981, 80, posamične najdbe gomile VI, 213, sl. 161: a, tretja vrsta desno.

2 gumba (*sl. 5*: 2,3).

Dobiat 1982, 43, št. 3412–3421, t. 10: 39,45.

3. Nova vas – Kaštelir (*sl. 5*: 4)

En gumb pr. 1,8 cm.

Sakara Sučević 2004, 137, sl. 202.

4. Nezakcij (*sl. 5*: 5,6)

2 gumba pr. 1,8 cm. Nekoliko drugačna.

Mihovilić 2001, 233, t. 76: 47.

5. **Kastav – Veli Mišinac**, grob 1/1979 in posamične najdbe (*sl. 6*: 11,12)

Guštin 1987, 47 s, sl. 7: 7; 8: 3.

Cetinić 1996, 196, sl. 12.

Blečić 2002, 97 s, kat. št. 10.2 (44 gumbov pr. 1,8 cm in manjših); 98, t. 10: 10.3 (5 železnih gumbov pr. 1,67 cm); 98, t. 11: 10.5 (20 gumbov pr. 1,75 cm); 98, kat. št. 10.6 (7 železnih gumbov pr. 1,7 cm); 85, 98 s, t. 1: 10.8 (grob 1/1979: 4 gumbi pr. 0,82 cm); 99, t. 11: 10.09 (8 gumbov pr. 0,83 cm); 99, kat. št. 10.10 (2 gumba pr. 1,8 cm); 99, kat. št. 10.11 (en gumb pr. 1,87 cm).

6. **Grobnik – Grobišće**, grob 2/1987 in posamične najdbe (*sl. 6*: 14–16)

Ljubić 1889, 155, št. 11.

Blečić 2004, 57 s, sl. 17 (grob 2/1987); 75, t. 7: 5.1.1 (7 gumbov pr. 0,82–0,93 cm), 5.1.2 (7 gumbov pr. 1,31 cm); 75, kat. št. 5.1.3 (43 gumbov pr. 1,34 cm); 76, t. 7: 5.1.6 (61 gumbov pr. 1,72 cm); 76, kat. št. 5.1.7 (1 gumb pr. 1,24 cm); 77, t. 8: 5.1.11 (15 gumbov pr. 1,24 cm).

7. Garica

Neobjavljeni. Podatek Martine Blečić Kavur.

8. Baška, grobova 1 in 3 (*sl. 5*: 7,8)

9 kalotastih gumbov (vrste Vinica in preprostih) pr. 1,1 do 1,7 cm (grob 1) in en gumb pr. 1,2 cm (grob 3).

Lo Schiavo 1970, 425, grob 1, št. 2, t. 24: 2; 426, grob 3, št. 3a, t. 24: 14.

9. Otok Krk (*sl. 5*: 9)

Večje število različno velikih gumbov.

Lo Schiavo 1970, 425, kat. št. 230, t. 23: 12a.

10. Prozor, grob 52 (*sl. 6*: 7)

114 različno velikih kalotastih gumbov (vrste Vinica in preprostih) s pr. od 0,4 do 1,5 cm. Gumbi so bili prišiti na usnjen pas.

Drechsler-Bižić 1972–1973, 37, grob 52, št. 14, t. 28: 14.

Bakarić 1993, 115, kat. št. 96, n.

11. Ribić, grobova 33 in 273 (*sl. 5*: 10,11)

En gumb pr. 1,8 cm (grob 33) in eden pr. 1,6 cm (grob 273).

Čurčić 1900, 9, grob 33; 28, grob 273, št. 9.

Marić 1968, 37, t. 22: 3; 20: 20.²¹

Dragan Božić

Inštitut za arheologijo

Znanstvenoraziskovalnega centra SAZU

Novi trg 2

SI-1000 Ljubljana

dragan.bozic@zrc-sazu.si

²¹ Potem ko je bil članek že končan, me je Blečić Kavurjeva opozorila še na halštatskodobni grob 18 nekropole Gradine pri Dragišiću v Dalmaciji. V njem sta bila najdena vsaj dva kalotasta gumba (Brusić 1999, t. 16: 1,2). Ker Brusićeva objava nima kataloga, ne vemo, kje v grobu sta ležala. Večji ima polno izboklino, manjši pa je neokrašen. Gumb z izboklino je podoben gumbom vrste Vinica, vendar se od njih razlikuje po tem, da je odprtina v zanki izredno majhna in da je izboklina razmeroma visoka. Po tem mu je blizu gumb iz groba 19 iste nekropole (ib., t. 17: 6), ki ima prav tako zelo majhno odprtino, a še višjo izboklino in strešast, ne pa zaobljen presek. Razmeroma blizu sta mu tudi gumba iz Nezakcija (*sl. 5*: 5,6), o katerih sem že navedel, da sta drugačna od običajnih gumbov vrste Vinica. Grob 18 iz Dragišića je zaradi jantarnih jagod in bronaste šivanke (ib., t. 16: 5,6) nedvomno ženski. Glede na to, da je Brusić od 160 kalotastih gumbov v grobu 4B nekropole pri Dragišiću (ib., 8, t. 27: 2) objavil risbo enega samega (ib., t. 4: 4), je verjetno, da je bilo tudi v grobu 18 precej več gumbov kot samo dva. Če so ležali v predelu pasu, je bil z njimi okrašen pas, ki bi ga lahko šteli za predhodnika poznolatskih ženskih pasov, okovanih z gumbi vrste Vinica in preprostimi kalotastimi gumbi.