

# THE HIGH-TEMPERATURE CHARACTERISATION OF WELDED JOINTS USING SMALL-PUNCH TESTING

## VISOKOTEMPERATURNA KARAKTERIZACIJA ZVARNIH SPOJEV Z UPORABO PREIZKUŠANJA SMALL-PUNCH

Karel Milička, Ferdinand Dobeš

Institute of Physics of Materials, AS CR, Žitkova 22, 616 62 Brno, Czech Republic  
milicka@ipm.cz

Prejem rokopisa – received: 2003-10-01; sprejem za objavo – accepted for publication: 2004-03-10

The paper presents the results of an investigation to test the applicability of small-punch tests on small, thin discs for characterizing welds. Both basic types of tests, i.e., tests with a constant penetrating force and tests with a constant penetrating rate of the punch were performed at 873 K. The tests appear to be useful for characterizing and analysing welds. Some experiences related to applications of the tests are summarized.

Key words: small-punch testing, weld

V članku so predstavljeni rezultati raziskave s ciljem preverjanja uporabnosti preizkusa small-punch za karakterizacijo zvarov. Obe temeljni vrsti preizkusa, preizkus s konstantno silo penetracije in s stalno hitrostjo penetracije, sta bila izvršena pri 873 K. Preizkus se je pokazal kot primeren za karakterizacijo in analizo zvarov. Predstavljene so izkušnje in uporabe preizkusa.

Ključne besede: preizkus small-punch, zvari

### 1 INTRODUCTION

The use of small-punch (SP) tests on miniaturized, thin discs is considered to be a potentially powerful way of characterizing their mechanical properties<sup>1</sup>. In SP tests, a small punch penetrates a thin disc into a hole (Figure 1). The thickness of the disc specimens – which is generally of the order of tenths of a millimetre – and planar dimensions up to ten millimetres – provides a number of testing advantages:

- only a small volume of the material under investigation is needed;
- the possibility of selecting the tested material from a very localized volume;
- the possibility of controlling and analyzing the structure of virtually the entire volume of the specimen; both surfaces of the test specimen are generally processed by techniques used in surface metallography.

As a rule, two basic types of SP test are performed:

- The punch penetrates through the disc at a given constant displacement rate and the necessary force is measured<sup>2</sup>. This test is referred to as the **CPR** (Constant Penetrating Rate) test in what follows. During this test the relationship between the instantaneous force,  $F$ , and the central disc deflection,  $\delta$ , i.e.,  $F = F(\delta)$  of the disc specimen, is measured. This test is similar to a stress vs. strain test under a constant strain rate.
- The **CPF** (Constant Penetrating Force) test involves the punch penetrating under a constant force,  $F$ , and the time dependence of the deflection,  $\delta$ ,  $\delta = \delta(t)$ , is

recorded<sup>3</sup>. This test is similar to the conventional constant-load creep test.

Both of these tests are run until the disc bursts. Usually, the punch is a ball or a bar with a hemispherical tip. Both types of SP test can also be performed at elevated temperatures, and so need a protective atmosphere.

Attempts to apply the SP tests have been verified over the past decade with the aim to prove their use in the assessment of the safety of serviced parts in power-plants facilities<sup>4,5</sup>. Because the specimens are extracted from the surface of these parts and the extraction

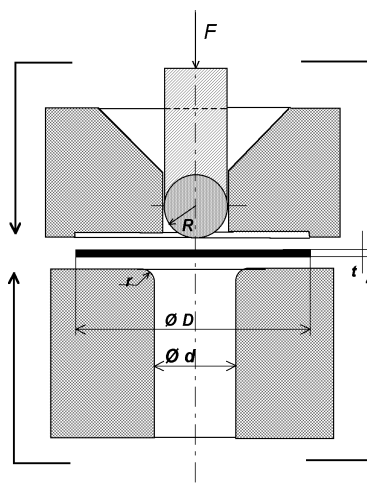

Figure 1: Scheme of the arrangement for small-punch tests on thin discs

Slika 1: Shema naprave za preizkus small-punch tankih diskov

does not usually affect their service, these techniques are classified as non-invasive. However, the problem of using surface specimens to describe the volume properties of the part is crucial in such an application <sup>6</sup>.

The possibility to investigate strain behaviour in a very small and localized volume, and to analyze the structure of the disc, is very advantageous for investigating and describing or mapping the distribution of this behaviour in a greater inhomogenous volume. Typical examples of such volumes are welds. Therefore, a systematic study of the application of SP tests in weld analyses is being performed at the IPM AS CR Brno. Some experiences resulting from this study are summarized in this paper.

## 2 EXPERIMENTAL

For the experiments we used a model V-type weld of two pipes with an external diameter of 324 mm and a wall thickness of 45 mm made from a Czech steel ČSN 15 128.5 (DIN equivalent 14 MoV 6 3) prepared at VÍTKOVICE Steel. The parent metal had the following composition (wt. %): 0.14 C, 0.54 Mn, 0.25 Si, 0.013 P, 0.006 S, 0.58 Cr, 0.46 Mo, 0.3 V, 0.006 Al, 0.06 Cu, 0.12 Ni, 0.0046 O, 0.011 N and Fe bal. The welding consisted of two combined procedures – TIG and manual arc welding. The TIG procedure (141) with GI 321 rods was used for a radix level. For manual arc welding (111), electrodes from E-B 321 were used. A micrograph and a scheme of the weld are presented in **Figures 2 and 3**, respectively.

The choice of the testing discs is clear from **Figure 3**. Two cylinders of 8-mm diameter were cut from various depths of the weld with the cylinder axis parallel to the pipe axis. The cylinders were subsequently spark cut to slices of 1.1 mm thickness in a direction from the centre of the weld; the cutting plane was parallel with the fusion line; the cutting layer was approximately 0.2 mm thick. The ellipse-shaped slices were treated by grinding into a circular form and then equally ground from both sides to a thickness of  $(0.500 \pm 0.002)$  mm, with the final

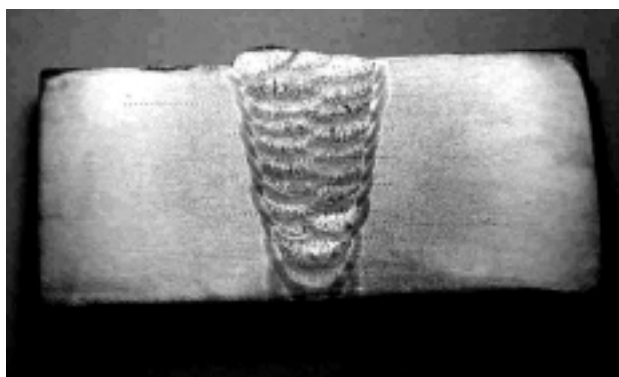

**Figure 2:** Macrograph of the experimental weld  
**Slika 2:** Makroposnetek preizkusnega zvara

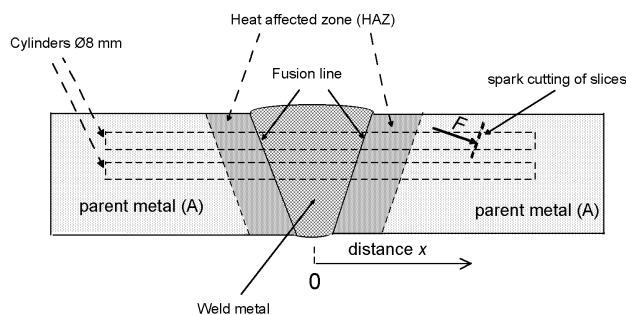

**Figure 3:** Scheme of the weld, illustration of sample selections  
**Slika 3:** Shema zvara, mesta odvzema preizkušancev

polishing on 1200-grade paper. A reference coordinate  $x$  of the disc centre from an assumed centre plane of the weld characterized the position of each specimen in the weld. In several cases both surfaces of the discs were also prepared for more detailed microstructure investigations (optical and SEM). An example of a disc specimen before and after a SP test is shown in **Figure 4**.

The parameters of the small-punch arrangement were:

diameter of the disc, $\phi D$	8.0–0.1 mm
thickness of the disc, $t$	$0.500 \pm 0.002$ mm
diameter of puncher $\phi 2R$ ceramic ball from FRIALIT® F99.7	$2.500 \pm 0.001$ mm
diameter of the hole in the lower die $\phi d$	$4.00 \pm 0.01$ mm
radius $r$ (lower die)	$\approx 0.20$ mm

The arrangement was put into an adapted creep machine. The testing facility allows both types of SP test to be made in a protective atmosphere and at temperatures ranging from room temperature to 1173 K. In all tests the force  $F$  acted on the disc in a direction away from the central plane of the weld. Both types of SP test were performed at 873 K in a protective atmosphere of dried and purified argon. During the tests the temperature was kept constant to within  $\pm 1$  K.

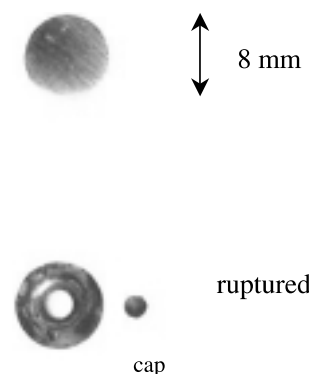

**Figure 4:** Samples for small-punch tests  
**Slika 4:** Preizkušanci za preizkus small-punch

### 3 RESULTS

#### 3.1 CPF tests

All the CPF tests were performed at a force  $F = 500$  N. A typical example of a CPF test is illustrated in **Figure 5**. The similarity of the curve to creep curves obtained in conventional tests is apparent. Thus, analogous characteristics can be defined from the CPF test – the deflection,  $\delta$ ; the minimum deflection rate,  $\dot{\delta}$ ; the time-to-fracture,  $t_f$ ; the total deflection,  $\delta_f$ , at fracture; etc. The dependence of the time-to-fracture,  $t_f$ , on the distance  $x$  is plotted in **Figure 6**. The plot clearly shows that the dependence exhibits a minimum of the force  $F$ . Such behaviour is to be expected. The minimum fracture time,  $t_f$ , in the vicinity of the weld-fusion line is about three times shorter than the time corresponding to the unaffected parent material.

#### 3.2 CPR tests

All the CPR tests were performed at the deflection rate  $\dot{\delta} = 5 \cdot 10^{-5}$  mms<sup>-1</sup>. A typical curve  $F = F(\delta)$  is illustrated in **Figure 7**. From the curve, several characteristics similar to those obtained from conventional tests,  $\sigma = \sigma(\epsilon)$ , i.e., an "elastic" region, the maximum force,  $F_{max}$ , the deflection to the massive gap rise, etc., can be derived. The dependence of the maximum force,  $F_{max}$ , on the distance  $x$  is plotted in **Figure 8**. It is apparent that  $F_{max}$  significantly changes with the distance  $x$ ; the shape of the plot corresponds to expectations. Typically, the weld is of a "hard" type.

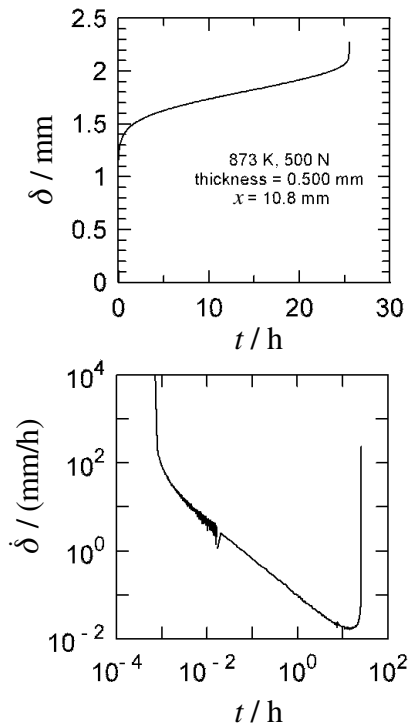

**Figure 5:** Example of a CPF test plot  
**Slika 5:** Primer odvisnosti pri CPF-preizkusu

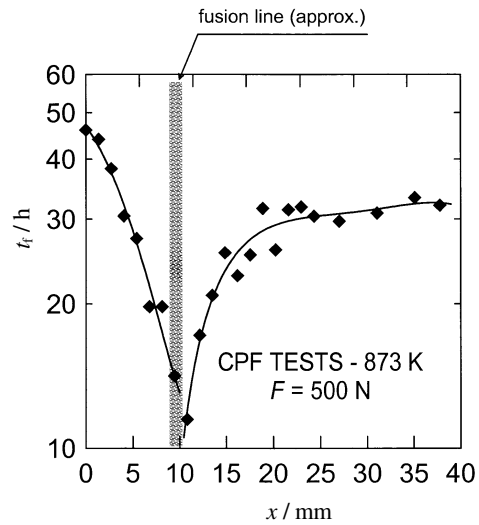

**Figure 6:** Dependence of time-to-fracture  $t_f$  on distance  $x$  – CPF tests  
**Slika 6:** Odvisnost časa  $t_f$  do zloma od razdalje  $x$  – CPF-preizkus

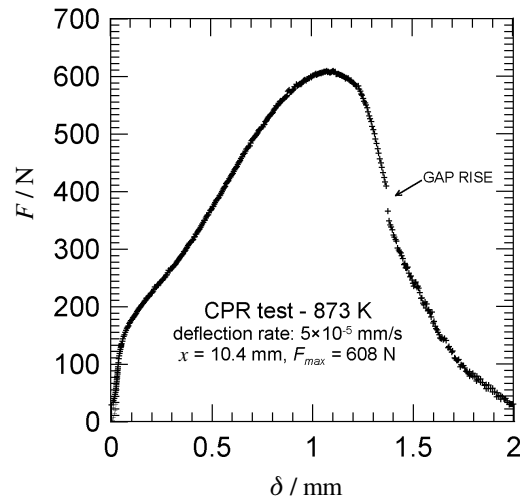

**Figure 7:** Example of a CPR test plot  
**Slika 7:** Primer CPR-preizkusa

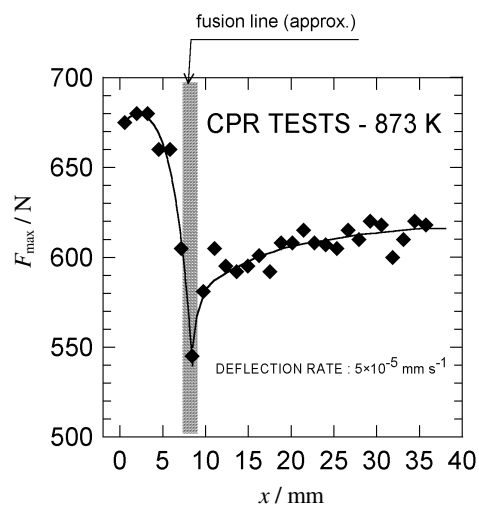

**Figure 8:** Dependence of  $F_{max}$  on coordinate  $x$  – CPR tests  
**Slika 8:** Odvisnost  $F_{max}$  od koordinate  $x$ , CPR-preizkus

#### 4 DISCUSSION

The results of both SP tests showed that the parameters derived from their plots strongly depend on the position from which the specimen was taken. The dependence seems to correspond to the scheme of the assumed distribution of strength in various parts of the weld. From the dependences of  $F_{\max}$  in the CPR tests, and the time-to-fracture,  $t_f$ , in the CPF tests, on the distance  $x$ , it can be deduced that both these parameters probably increase – though slightly – even at relatively large distances of  $x$ . Nevertheless, it can be deduced that the minimum observed time-to-fracture,  $t_f$ , in the CPF tests is approximately three times shorter than the average value corresponding to the unaffected parent material of the welded segments. Note that the CPF tests were relatively short-term. From results of the CPR tests it follows that the difference between the minimum value of  $F_{\max}$  and the average value of  $F_{\max}$  for the parent material is greater than 60 N; the difference between this minimum value and the values of the weld material is much greater – approximately 150 N.

With respect to these results, it can be deduced that both types of SP test can be considered as suitable for complex investigations of the distribution of strength properties in the weld volume. However, such a conclusion gives rise to several questions or problems that should be discussed. Let us mention at least some of these problems:

1. It must be emphasized that all the above results were obtained at a temperature of 873 K, which is close to the usual service temperature of low-alloy steel pipes. In fact, the SP tests can be performed over a large temperature interval. This fact, together with the possibility for also performing long-term SP tests (longer than 1000 h), can be considered very convenient for the application of these tests.
2. A direct interpretation of results of the SP tests necessitates a knowledge of their relationships to the parameters usually obtained from the analogous tests on massive specimens, i.e., creep tests and stress-strain tests. The majority of modern procedures of weld modelling deal with characteristics resulting from conventional tests. However, a knowledge of these relationships is a crucial issue in any application of SP tests results, and great attention must be given to it. Some recent investigations have shown that, at least in some cases, this issue may be resolvable. For example, it was shown that there is a simple linear relationship between the force  $F$  in the CPF test and the applied stress  $\sigma$  acting in creep at an identical fracture time and a given temperature in frequently used heat-resistant steels<sup>7</sup>. Apparently simpler is a case in which the SP test results can only serve as a qualitative comparison of the strength properties of two or more materials. Probably, the results of suitable SP tests should be considered sufficient for such purposes.

3. The problem of determining the exact position of the specimen and its surfaces with respect to the fusion line must be solved. This issue should not be too troublesome; it needs only the introduction of some suitable markers or procedures allowing a quite specific choice of specimen position. In the present investigation, the position of the fusion line was determined relatively roughly.
4. A more detailed mapping of the properties by means of SP tests could be achieved by using smaller and thinner disc specimens. This question is closely connected with the principal problems of the SP techniques, such as the choice of parameters of the SP experimental arrangement, the procedure of specimen preparation (influence of spark cutting, etc.) and – finally – some material properties, e.g., the relationship between allowable disc thickness and the grain size of the material.

#### 5 CONCLUSIONS

The following conclusions can be drawn from the application of small-punch (SP) tests to the weld of a particular type of heat-resistant steel:

- both types of SP test appear to be useful tools for the analysis of the strength distribution over the whole weld volume;
- the relationships between the results of the SP tests and the corresponding conventional tests are a possible way of applying SP results in existing procedures of weld analyses; any direct application of SP results needs further investigation.
- applications of SP tests necessitate preferential solutions of some method-related problems.

**ACKNOWLEDGEMENTS.** The financial support of the Grant Agency of the Czech Republic as part of grant 106/03/1353 is gratefully acknowledged.

#### 6 REFERENCES

- <sup>1</sup> G. E. Lucas, *Met. Trans.* 21A (1990), 1105
- <sup>2</sup> J. M. Baik, J. Kameda, O. Buck, *Scripta Met.*, 17 (1983), 92
- <sup>3</sup> J. D. Parker, J. D. James, Disc-bend Creep Deformation Behaviour of  $\frac{1}{2}\text{Cr}/\frac{1}{2}\text{Mo}/\frac{1}{4}\text{V}$  Low Alloy Steel. Proc. 5<sup>th</sup> Int. Conf. on the Creep and Fracture of Engineering Materials and Structures, 651. The Institute of Metals, London, 1993, 651
- <sup>4</sup> T. Misawa, T. Adachi, M. Saito, Y. Hamaguchi, *J. Nucl. Mat.* 150 (1987), 194
- <sup>5</sup> J. D. Parker, Stratford, G. C. Shaw, N. H. Metcalfe: The Application of Miniature Disc testing for the Assessment of Creep Damage in CrMoV Rotor Steel. Baltica IV – Plant Maintenance for Managing Life & Performance, VTT Symposium. Helsinki – Stockholm, September 2 (1998), 477
- <sup>6</sup> K. Milička, F. Dobeš: Comparison of small punch tests performed on exposed power plant part. Baltica V – Condition and Life Management for Power Plants, VTT Symposium. Porvoo, Finland 1 (2001), 383
- <sup>7</sup> F. Dobeš, K. Milička, *J. Test. Eval.*, 29 (2001), 31