

Sneža Tecco Hvala

Magdalenska gora

Družbena struktura in grobni
rituali železnodobne skupnosti

Social structure and burial rites
of the Iron Age community



Zbirka / Series
Uredniki zbirke / Editors of the series

OPERA INSTITUTI ARCHAEOLOGICI SLOVENIAE 26
Jana Horvat, Andrej Pleterski, Anton Velušček

Sneža Tecco Hvala

MAGDALENSKA GORA.
Družbena struktura in grobni rituali železnodobne skupnosti
MAGDALENSKA GORA.
Social structure and burial rites of the Iron Age community

Recenzenta / Reviewed by Biba Teržan, Janez Dular
Prevod / Translation Andreja Maver
Jezikovni pregled / Language Editors Marjeta Humar
Tehnična ureditev / Technical Editor Mateja Belak
Oblikovanje ovitka /
Front cover design Ivian Kan Mujezinović
Risbe / Drawings Dragica Knific Lunder
Računalniški prelom / DTP Mateja Belak
Priprava slikovnega gradiva /
Preparation of illustrations Drago Valoh, Mateja Belak
Izdala in založila / Published by Inštitut za arheologijo ZRC SAZU, Založba ZRC
Zanju / Represented by Oto Luthar, Jana Horvat
Glavni urednik / Editor-in-Chief Aleš Pogačnik

Izid knjige sta podprla /
Published with the support of

Javna agencija za knjigo RS, Znanstvenoraziskovalni center SAZU

CIP - Kataložni zapis o publikaciji
Narodna in univerzitetna knjižnica, Ljubljana

903.5(497.4Magdalenska gora)"638"(0.034.2)

TECCO Hvala, Sneža

Magdalenska gora [Elektronski vir] : družbena struktura in grobni rituali železnodobne skupnosti = Magdalenska gora : social structure and burial rites of the Iron Age community / Sneža Tecco Hvala ; [prevod, translation Andreja Maver ; risbe, drawings Dragica Knific Lunder ; priprava slikovnega gradiva, preparation of illustrations Drago Valoh, Mateja Belak]. - El. knjiga. - Ljubljana : Inštitut za arheologijo ZRC SAZU, Založba ZRC, 2013. - (Opera Instituti Archaeologici Sloveniae, ISSN 1408-5208 ; 26)

Vzpor. besedilo v slov. in prevod v angl.

ISBN 978-961-254-600-7 (pdf)

<https://doi.org/10.3986/9789612546007>

269257984



© 2012, ZRC SAZU, Inštitut za arheologijo, Založba ZRC

Vse pravice pridržane. Noben del te knjige ne sme biti reproduciran, shranjen ali prepisan v kateri koli obliki oz. na kateri koli način, bodisi elektronsko, mehansko, s fotokopiranjem, snemanjem ali kako drugače, brez predhodnega pisnega dovoljenja lastnikov avtorskih pravic.

All rights reserved. No part of this publication may be reproduced, stored in a retrieval system or transmitted, in any form or by any means, electronic, mechanical, photocopying, recording or otherwise, without the prior permission of the publisher.

Sneža Tecco Hvala

MAGDALENSKA GORA

**Družbena struktura in grobni rituali
železnodobne skupnosti**

MAGDALENSKA GORA

**Social structure and burial rites
of the Iron Age community**



LJUBLJANA 2012

VSEBINA

Predgovor	11
Pojasnila k rabi oznak	13
1 Viri in metodološki pristop	15
1.1 Viri	15
1.1.1 Najdbe	18
Najdbe v Narodnem muzeju Slovenije	18
Najdbe v Naravoslovnem muzeju na Dunaju	21
Najdbe v Peabodyjevem muzeju	22
1.1.2 Dokumentacija o izkopavanjih	24
1.1.3 Analize kostnih ostankov	27
Zoološki ostanki	28
Antropološki ostanki	31
1.2 Metodološki pristop	38
2 Kulturno-kronološki okvir	41
3 Pogrebni običaji	49
3.1 Lega in struktura grobišč	49
3.2 Način pokopa	50
3.2.1 Žgani pokopi	50
Žarni grobovi	55
Grobovi z žganino, raztreseno po dnu jame	69
Žgani pokopi v kamnitih skrinjah	70
Žgani grobovi z leseno podlogo?	76
3.2.2 Skeletni grobovi	79
3.2.3 Skupni pokopi	82
3.2.4 Živalski ostanki v grobnem kultu	89
3.3 Grobni pridatki	93
3.3.1 Grobovi brez pridatkov	97
3.3.2 Grobovi s keramiko brez drugih pridatkov	103
3.3.3 Grobovi z orožjem in nakitom	106
4 Oprave	109
4.1. Orožje	109
4.1.1 Sekire	109
Križne sekire	109
Sekire z dvostranskimi plavutmi	111
Tulaste sekire	114
Sekire z enostranskimi plavutmi	118
Uhate sekire	119

CONTENTS

Preface	11
Marks and abbreviations	13
1 Sources and methodological approach	15
1.1 Sources	15
1.1.1 Finds	18
Finds in the National Museum of Slovenia	18
Finds in the Natural History Museum in Vienna	21
Finds in the Peabody Museum	22
1.1.2 Documentation of the excavations	24
1.1.3 Analyses of bone remains	28
Zoological remains	29
Anthropological remains	31
1.2 Methodological approach	38
2 Cultural and chronological outline	41
3 Funerary customs	49
3.1 Cemetery layout and structure	49
3.2 Burial rite	50
3.2.1 Cremation burials	50
Urn graves	56
Cremated remains in grave pit	70
Cremation burials in stone cists	71
Cremation graves with a wooden bedding?	76
3.2.2 Inhumation burials	79
3.2.3 Multiple burials	82
3.2.4 Animal remains in the funerary cult	89
3.3 Grave goods	93
3.3.1 Graves without grave goods	97
3.3.2 Graves with pottery as the only grave good	103
3.3.3 Graves with weapons and jewellery	106
4 Outfit	109
4.1 Weapons	109
4.1.1 Axes	109
Lugged axe	109
Winged axe	111
Socketed axes	114
One-sided winged axes	118
Shaft-hole axes	119

4.1.2	Sulice, kopja in puščice	123
	Osti sulic in kopij	123
	Puščične osti	128
4.1.3	Bodala in meči	131
	Bodala	131
	Meči	133
4.1.4	Noži in britve	135
4.2	Čelade	143
	Stožčaste čelade	149
	Sestavljene čelade	150
	Dvogrebenaste čelade	151
	Negovske čelade	153
4.3	Konjska oprema, ostroge in dereze	157
4.3.1	Konjske brzde in jermensko okrasje	157
4.3.2	Ostroge	163
4.3.3	Dereze	164
4.4	Pasne sponje	164
4.4.1	Železne rombične in pravokotne sponje	165
4.4.2	Bronaste pravokotne sponje	171
4.4.3	Kavljaste in predrte pasne sponje	179
	Kavljaste pasne sponje s sredinsko prečko	179
	Predrte pasne sponje	181
4.5	Žezla in ražnji	185
4.5.1	Žezla	185
4.5.2	Ražnji ali oboloi	188
4.6	Igle	189
4.7	Fibule	195
4.7.1	Enozankaste fibule	195
	Enozankaste fibule z žičnatim lokom	195
	Enozankaste fibule z listastim lokom	198
4.7.2	Dvozankaste fibule	199
4.7.3	Čolničaste fibule	208
4.7.4	Dvo- ali trortaste fibule	218
	Trortaste fibule	218
	Dvortaste fibule	224
4.7.5	Fibule z oblogo	226
4.7.6	Kačaste fibule	231
4.7.7	Trakaste, dolgonožne in drobne ločne fibule	242
	Trakaste fibule	242
	Dolgonožne fibule	244
	Drobne ločne fibule	246
4.7.8	Certoške fibule	247
4.7.9	Figuralne in samostrelne fibule	258
	Figuralne fibule	258
	Vzhodnoalpske živalske fibule	263
	Samostrelne fibule z okrasno nogo	265
	Pavkaste fibule	266
4.7.10	Zaključek	267
4.8	Ovratnice in ogrlice	270
4.8.1	Ovratnice	270
4.8.2	Ogrlice	280
	Jantarne ogrlice	280
	Steklene ogrlice	287

4.1.2 Spears, javelins and arrows	123
Spear- and javelinheads	123
Arrowheads	128
4.1.3 Daggers and swords	131
Daggers	131
Swords	133
4.1.4 Knives and razors	135
4.2 Helmets	143
The conical helmets	150
Composite helmets	151
Double-crested helmets	152
Negova helmets	153
4.3 Horse gear, spurs and crampons	157
4.3.1 Bridle-bits and strap decoration	157
4.3.2 Spurs	164
4.3.3 Crampons	164
4.4 Belt clasps	165
4.4.1 Iron rhombic and rectangular clasps	165
4.4.2 Bronze rectangular clasps	171
4.4.3 Hook and openwork belt clasps	180
Hook belt clasp with a central bar	180
Openwork belt clasp	181
4.5 Maces and spits	185
4.5.1 Maces	185
4.5.2 Spits or oboloi	188
4.6 Pins	190
4.7 Fibulae	195
4.7.1 Single-looped fibulae	195
Single-looped fibulae with a wire bow	195
Single-looped fibulae with a leaf bow	197
4.7.2 Two-looped fibulae	198
4.7.3 Boat fibulae	208
4.7.4 Two- or three-knobbed fibulae	218
Three-knobbed fibulae	218
Two-knobbed fibulae	224
4.7.5 Fibulae with a bow overlay	226
4.7.6 Serpentine fibulae	231
4.7.7 Band, long-footed and small bow fibulae	243
Band bow fibulae	243
Long-footed fibulae	244
Small bow fibulae	246
4.7.8 Certosa fibulae	247
4.7.9 Figural and various crossbow fibulae	258
Figural fibulae	258
East Alpine animal-headed fibulae	264
Crossbow fibulae with a decorated foot	265
Kettledrum fibulae	267
4.7.10 Conclusion	268
4.8 Torques and necklaces	272
4.8.1 Torques	272
4.8.2 Necklaces	281
Amber necklaces	281
Glass necklaces	287

4.9 Zapestnice, narokvice in nanožnice	290
4.9.1 Železne zapestnice	290
4.9.2 Bronaste zapestnice, narokvice in nanožnice	291
Polne gladke zapestnice in nanožnice	291
Polne narebrene zapestnice in nanožnice	299
Spiralne žičnate ali trakaste zapestnice in narokvice	310
Votle zapestnice in nanožnice	313
4.9.3 Svinčene narokvice	321
4.9.4 Zaključek	324
4.10 Uhani in lasni obročki	327
4.10.1 Žičnati uhani ali lasni obročki	328
4.10.2 Trakasti uhani ali lasni obročki	329
4.10.3 Valjasti uhani ali lasni obročki	331
4.11 Scepri, diadem in zlat nakit	334
4.11.1 Scepri	334
4.11.2 Diadem in zlat nakit	339
4.12 Drugi pridatki	341
5 Nastanek in razvoj magdalenskogorske skupnosti	343
Faza I	343
Faza II	347
Faza III	350
Faza IV	352
Faza V	358
Faza VI	361
6 Družbeni in kulturni procesi v starejši železni dobi	363
Teritorialna organizacija	363
Družbena struktura in diferenciacija	370
Kultno-religiozna sfera	384
7 Literatura	389
8 Indeks grobov	409

4.9 Bracelets, armlets and anklets	290
4.9.1 Iron bracelets	290
4.9.2 Bronze bracelets, armlets and anklets	291
Solid plain bracelets and anklets	291
Solid ribbed bracelets and anklets	301
Spiral wire or band bracelets and armlets	310
Hollow bracelets and anklets	314
4.9.3 Lead armlets	322
4.9.4 Conclusion	324
4.10 Ear- and hair-rings	327
4.10.1 Wire ear- or hair-rings	328
4.10.2 Band ear- or hair-rings	329
4.10.3 Cylindrical ear- or hair-rings	331
4.11 Sceptres, diadems and gold jewellery	334
4.11.1 Sceptres	334
4.11.2 Diadem and gold jewellery	339
4.12 Other grave goods	341
5 Beginning and development of the Magdalenska gora community	343
Phase I	343
Phase II	347
Phase III	349
Phase IV	352
Phase V	358
Phase VI	361
6 Social and cultural processes in the Early Iron Age	363
Territorial organisation	363
Social structure and differentiation	370
Cult and religious sphere	383
7 Bibliography	389
8 Index of graves	409

PREDGOVOR

PREFACE

“Gomile na Gori pod cerkvijo sv. Magdalene pri Šmarju hranijo toliko lepih in zanimivih starin, da bi se ž njimi napolnil mal muzej”, je davnega leta 1893 zapisal Jernej Pečnik, eden od izkopavalcev na tem pomembnem najdišču iz starejše železne dobe. Izkopanine, ki so prišle na dan v več akcijah pred prvo svetovno vojno, so doživljale različno usodo in nazadnje pristale v muzejskih zbirkah v raznih državah.

Deziderat povojne slovenske prazgodovinske arheologije je bil dokumentirati, objaviti in ovrednotiti arheološko gradivo, ki ga s slovenskih najdišč hranijo tuji muzeji. Na pobudo akad. prof. dr. Staneta Gabrovca ter s prizadevanjem njegovih študentov in strokovnjakov za prazgodovino, ki so izšli iz Arheološkega seminarja v Ljubljani, je bil ta cilj v precejšnji meri izpolnjen, vsaj kar zadeva Naravoslovni muzej na Dunaju, s katerim je bilo vzpostavljeno zgledno sodelovanje po zaslugi dr. Wilhelma Angelija, dr. Fritza Eckarta Bartha, dr. Angelike Heinrich in dr. Antona Kerna.

Z magdalenskogorskimi najdbami sem se поблиže seznanila v začetku osemdesetih let ob pripravi diplomske naloge na Oddelku za arheologijo Filozofske fakultete pri Univerzi v Ljubljani, ki sva si jo delili z Evo Kocuvan. Naloga je zajemala dokumentiranje in obdelavo gradiva, ki ga z Magdalenske gore hranita Naravoslovni muzej na Dunaju in Narodni muzej Slovenije v Ljubljani, nastala pa je pod mentorstvom prof. Gabrovca in njegove tedanje asistentke Bibe Teržan, ki je delo ves čas zavzeto spremljala. Katalog najdb, dopolnjen z arhivskimi viri in rekonstrukcijo poteka raziskav, je nazadnje dočkal objavo leta 2004 v sodelovanju z dr. Janezom Dularjem. Ob tem smo na novo izdelali topografski načrt najdišča in identificirali nekatere grobne celote v tipološko urejeni zbirki ljubljanskega muzeja. Najdbe, ki jih s tega najdišča hrani Peabodyjev muzej pri Harvardski univerzi v Cambridgeu (Massachusetts, ZDA), pa je že leta 1978 objavil ugledni ameriški raziskovalec evropske prazgodovine Hugh Hencken. Še poprej sta leta 1968 izšli razpravi o človeških in živalskih kostnih ostankih iz Mecklenburške zbirke v tem muzeju. Omenjena temeljna dela so skupaj z drugimi študijami starejše železne dobe v jugovzhodnih Alpah ponujala dobro izhodišče

It was an observation noted in 1893 by Jernej Pečnik, one of the excavators at Magdalenska gora, that the tumuli at ‘Gora’ below the church of St. Mary Magdalene kept so many beautiful and interesting finds as to fill a small museum. The truly numerous and rich finds from this very important site of the Early Iron Age were coming to light during several campaigns conducted prior to World War I. They now form part of several museum collections across the world, while they were published entirely after World War II.

It was one of the aims of the post-war Slovenian archaeology to document, publish and assess the archaeological material from Slovenian sites kept in foreign museums. On the incentive of Stane Gabrovec and through the efforts on the part of his students and experts in prehistory educated at the Department of Archaeology in Ljubljana, this aim was largely realized. This was particularly true of the finds kept in the Museum of Natural History in Vienna, the cooperation with which was fostered by Wilhelm Angeli, Fritz Eckart Barth, Angelika Heinrich and Anton Kern.

Personally, I became better acquainted with the finds from Magdalenska gora in the early 1980s while working, together with Eva Kocuvan, on the graduate thesis at the Department of Archaeology at the Faculty of Arts, University of Ljubljana. The thesis, written under the mentorship of Stane Gabrovec and Biba Teržan, involved documenting and analysing the material unearthed at Magdalenska gora and kept in the Museum of Natural History in Vienna and the National Museum in Ljubljana. The catalogue of finds, supplemented by archival sources and a reconstruction of the course of investigation, finally saw the light of day in 2004, written in collaboration with Janez Dular. The publication included an assessment of the topographic situation and a ground-plan of the site as well as an identification of several grave groups within the otherwise typologically arranged collection of the museum in Ljubljana. The finds kept in the Peabody Museum of Harvard University in Cambridge (Massachusetts, USA) had already been published in 1978 by Hugh Hencken, a renowned American researcher of European prehistory. Prior to

za nadaljnje analize in celovitejši vpogled v nastanek in razvoj te skupnosti, njene grobne rituale in družbeno strukturo, kar je tema te knjige.

Za recenzijo besedila, kritične pripombe in sugestije, ki so pripomogle k boljši kakovosti, se najlepše zahvaljujem akad. red. prof. dr. Bibi Teržan in dr. Janezu Dularju, ob katerem sem si tudi nabirala dragocene raziskovalne izkušnje na Inštitutu za arheologijo ZRC SAZU, kjer sem zaposlena. Prav tako so mi bili v veliko pomoč pogovori z dr. Draganom Božičem, dr. Jano Horvat in dr. Marjeto Šašel Kos. Zahvalo dolgujem še drugim sodelavcem inštituta, ki so sodelovali pri oblikovanju te knjige – Dragici Knific Lunder za risbe, Dragu Valohu za obdelavo slikovnega gradiva, Mateji Belak za grafični prelom, dr. Primožu Pavlinu in Andreji Dolenc Vičič za tehnični in Marjeti Humar za jezikovni pregled besedila, dr. Zvezdani Modrijan in Luciji Lavrenčič pa za prijateljsko spodbudo. Prav tako sem hvaležna sodelavcem Narodnega muzeja Slovenije, zlasti dr. Nevi Trampuž Orel in Barbari Jerin, ki sta mi vedno omogočili dostop do gradiva, kadar sem to potrebovala. Posebna zahvala gre prevajalki Andreji Maver za njeno vestno opravljeno delo in trud, ki ga je vložila v iskanje angleških ustreznih slovenske strokovne izraze.

Največjo zahvalo pa dolgujem svoji družini za moralno oporo – možu Simónu in sinu Simónu Juniorju, ki sta pravzaprav moja glavna življenjska motivacija, zato jima to delo tudi posvečam. Na koncu se želim pokloniti še spominu na mojo sestro Tanjo.

*Sneža Tecco Hvala
Ljubljana, oktober 2012*

that, in 1968, the studies of the human and animal bone remains from the Mecklenburg Collection of the Peabody Museum had been published. These publications represent basic works that afforded, together with other studies of the Early Iron Age in the south-eastern Alps, good grounds for further research as well as a greater insight into the beginning and development of the Magdalenka gora community, its funerary rituals and social structure, which is the topic of this book.

A review of the book, together with critical remarks and suggestions that led to further improvement of my text, was provided by Biba Teržan and Janez Dular, to whom I extend my sincere gratitude; it was also alongside Dular that I gained valuable research experience at the Institute of Archaeology at ZRC SAZU, where I am employed. Furthermore, I was greatly aided in writing this book by the discussions I had with Dragan Božič, Jana Horvat and Marjeta Šašel Kos. I would also like to thank other colleagues at the Institute who actively helped in shaping the publication, namely Dragica Knific Lunder for her drawings, Drago Valoh for preparing the illustrations, Mateja Belak for DTP, Primož Pavlin and Andreja Dolenc Vičič for technical editing and Marjeta Humar for language editing, as well as Zvezdana Modrijan and Lucija Lavrenčič for friendly support. I would like to thank my colleagues at the National Museum of Slovenia, particularly Neva Trampuž Orel and Barbara Jerin, who provided free access to the material kept there. I would also like to thank Andreja Maver for translating the text with diligence and accuracy.

My greatest gratitude, for their generous moral support, goes to my family – to my husband Simón and my son Simón Junior – to whom I dedicate this book. With it, I would also like to pay homage to my sister Tanja.

*Sneža Tecco Hvala
Ljubljana, October 2012*

Izkopavanja so na Magdalenski gori potekala v več kampanjah in vsak izkopavalec je po svoje označeval gomile, zato se oznake gomil mestoma podvajajo ali so celo potrjene. V skladu z njihovimi oznakami so popisane tudi najdbe v primarnih dokumentih, muzejskih inventarnih knjigah in objavah. V objavi gradiva, ki ga hranita ljubljanski in dunajski muzej, smo v orisu topografske situacije in na generalnem načrtu upoštevali prvotno številčenje gomil, v korelacijskih tabelah pa prikazali oznake, ki so jih za isto gomilo uporabljali razni izkopavalci.¹ Lege gomil, ki sta jih vojvodinja Mecklenburška in njen pomočnik Goldberg označila s številkami I do III, na terenu in topografskem načrtu ni mogoče identificirati.

Da bi se izognila zmedi, uporabljam v tej knjigi **rimске** številke za gomile, ki jih je kopala vojvodinja Mecklenburška, **arabske** številke pa za gomile, ki so bile kopane v okviru terenskih akcij ljubljanskega in dunajskega muzeja.² Za nedvoumno sklicevanje in citiranje grobnih celot navajam še ime ledine, na kateri stoji gomila, v tabelaričnih prikazih pa uporabljam spodaj navedene kratice in oznake.

Ledine:

- L = Laščik
- P = Preloge
- V = Voselca

Način pokopa:

- C = žgan
- S = skeleten

Spol ali starost pokojnika:

- A = odrasla oseba
- F = oseba ženskega spola
- I = otrok
- Iuv = mlada oseba
- M = oseba moškega spola

Muzeji:

- NHMW = Naturhistorisches Museum, Wien
- NMS = Narodni muzej Slovenije, Ljubljana
- PM = Peabody Museum of Archaeology and Ethnology, Harvard University, Cambridge, Massachusetts

Za časovno opredeljevanje uporabljam sledeče izraze:

- Starejša železna doba = halštatska doba (Ha)
- Starejše halštatsko obdobje (Ha C) = stopnja Podzemelj in stopnja Stična
- Mlajše halštatsko obdobje (Ha D1–LT B1) = stopnja kačastih in stopnja certoških fibul ter stopnja negovskih čelad
- Mlajša železna doba = latenska doba (LT)

Excavations at Magdalenska gora took place in several campaigns and each excavator used his own numbering of the uncovered tumuli and thus the same number may appear twice or even three times. These numbers are also used in the lists of finds in the primary documents, museum inventory books and in publications. The publication of the material kept at the museums in Ljubljana and Vienna respects the original numbering of tumuli in the topographical outline and on the general plan, while markings used by different excavators for the same tumuli are given in the correlation tables.¹ The positions of the tumuli excavated by the Duchess of Mecklenburg and her secretary Goldberg, and marked with numbers from I to III, could not be identified neither on the field nor on the topographical map.

To avoid confusion in the present book, **Roman** numerals are used to mark tumuli excavated by the Duchess of Mecklenburg, while the tumuli excavated within the campaigns of the Ljubljana and Vienna museums are marked with **Arabic** numerals.² For reasons of clarity, when citing or referring to individual graves, these are also marked by the name of the fallow where the tumulus stood, while the synoptically tables use the abbreviations and marks listed below.

Fallows:

- L = Laščik
- P = Preloge
- V = Voselca

Types of burial:

- C = cremation
- S = skeletal

Age or sex of deceased:

- A = adult
- F = female
- I = infant
- Iuv = young individual
- M = male

Museums:

- NHMW = Naturhistorisches Museum, Wien
- NMS = Narodni muzej Slovenije, Ljubljana
- PM = Peabody Museum of Archaeology and Ethnology, Harvard University, Cambridge, Massachusetts

The following terms are used for chronological determination:

- Early Iron Age = Hallstatt period (Ha)
- Early Hallstatt period (Ha C) = Podzemelj and Stična phases
- Late Hallstatt period (Ha D1–LT B1) = Serpentine Fibulae, Certosa Fibulae and Negova Helmets phases
- Late Iron Age = La Tène period (LT)

¹ Tecco Hvala/Dular/Kocuvan 2004, sl. 14, 21.

² Takšno rešitev je predlagala Teržanova in se zdi najbolj primerna (Teržan 2008, 211, op. 71).

¹ Tecco Hvala/Dular/Kocuvan 2004, Abb. 14, 21.

² This solution was proposed by Teržan and is deemed suitable (Teržan 2008, 211, n. 71).

1 VIRI IN METODOLOŠKI PRISTOP

1 SOURCES AND METHODOLOGICAL APPROACH

1.1 VIRI

Arheološka odkritja na Magdalenski gori so postavila ta kraj na zemljevid najpomembnejših središč železne dobe jugovzhodnoalpskega prostora. Naselbina sicer ni bila kopana, zato pa so pred stotimi leti delno ali v celoti raziskali malodane vse gomile v bližnji okolici (*sl. 1*).

Gradivo je danes v štirih državah. V *Narodnem muzeju Slovenije* v Ljubljani so shranjene najdbe, ki so bile odkrite od 1882 do spomladi 1893 ter nekaj malega predmetov iz arheološke zapuščine vojvodinje Mecklenburške. *Naturhistorisches Museum* na Dunaju hrani gradivo z izkopavanj v letih 1893 in 1894, pridobili so tudi manjše število predmetov od Centralne komisije in lokalnega zbiratelja starin Valentina Sadnikarja. Zbirko vojvodinje Mecklenburške, ki je na Magdalenski gori kopala v letih od 1905 do 1913, je odkupil *Peabody Museum* Harvardske univerze v Cambridgeu v ZDA.³ Med dragocenostmi, ki jih je vojvodinja podarila nemškemu cesarju Wilhelmu II., se je znašlo tudi nekaj kosov z Magdalenske gore, ki so sedaj v *Museum für Vor- und Frühgeschichte* v Berlinu.⁴

O terenskih akcijah obstaja skromna dokumentacija, zabeležena pretežno v pisni obliki; načrtov, skic grobov in predmetov ter fotografij je bolj malo z izjemo fotografskih posnetkov z izkopavanj vojvodinje Mecklenburške. Dokumentarno gradivo je arhivirano na različnih mestih. Dopise, poročila in korespondenco, ki vsebujejo podatke o terenskih raziskavah, je moč najti v *Arhivu Republike Slovenije* med listinami Deželnega zbora in odbora za Kranjsko ter Centralne komisije, razen tega v fasciklu spisov Jerneja Pečnika, pa tudi med zapuščino Simona Rutarja, shranjeno na rokopisnem oddelku *Narodne in univerzitetne knjižnice*. Izjemno dragoceni so podatki, ki so zabeleženi v dnevnikih Franza Brattine in Josefa Szombathyja ter v Szombathyjevi korespondenci iz arhiva dunajskega Naravoslovnega muzeja.⁵ Originalno dokumentacijo o terenskih akcijah

³ Gabrovec 1975b; id. 1990a.

⁴ Dobiati 1982, 19, 25; Weiss 1996; id. 1999, Abb. 66a,c, 67c, Taf. 19.

⁵ *Archiv RS*: fond AS 38, Deželni zbor in odbor za Kranjsko

1.1 SOURCES

Magdalenska gora figures among the most important centres of the Iron Age in the south-eastern Alpine area. It is a status attained through archaeological discoveries, though not in the settlement, which has not been excavated yet, but rather in the tumuli extending below, almost all of which were investigated a century ago, some partly, some entirely (*fig. 1*).

The material excavated at Magdalenska gora is scattered across four countries. The National Museum of Slovenia (*Narodni muzej Slovenije*) in Ljubljana keeps the finds unearthed from 1882 to the spring of 1893, as well as a small number of finds excavated by the Duchess of Mecklenburg. The Museum of Natural History in Vienna (*Naturhistorisches Museum Wien*) keeps the material unearthed in 1893 and 1894, as well as some finds acquired from the Central Commission for Art and Historical Monuments (*Zentralkommission zur Erforschung und Erhaltung der Kunst- und historischen Denkmale*) and the local antique collector Sadnikar. The bulk of the finds excavated between 1905 and 1913 by the Duchess of Mecklenburg was acquired by the *Peabody Museum* of Harvard University in Cambridge, USA, and is known today as the Mecklenburg Collection.³ The Duchess herself offered some of the prestigious finds to Emperor Wilhelm II, among them also several items from Magdalenska gora; these are now kept at the Museum of Prehistory and Early History (*Museum für Vor- und Frühgeschichte*) in Berlin.⁴

The field campaigns at Magdalenska gora are scantily documented, mostly in written form. Only a few plans and sketches of graves and finds exist, while there are a few more photographs, primarily those taken during the excavations by the Duchess of Mecklenburg. Similarly as the finds, the documentary material as well is scattered among archives in various institutions. Letters, reports and correspondence on the field investigations is kept at the Archives of the Republic of Slovenia (*Archiv Republike Slovenije*). Further information can be found among the

³ Gabrovec 1975b; id. 1990a.

⁴ Dobiati 1982, 19, 25; Weiss 1996; id. 1999, Abb. 66a,c, 67c, Taf. 19.

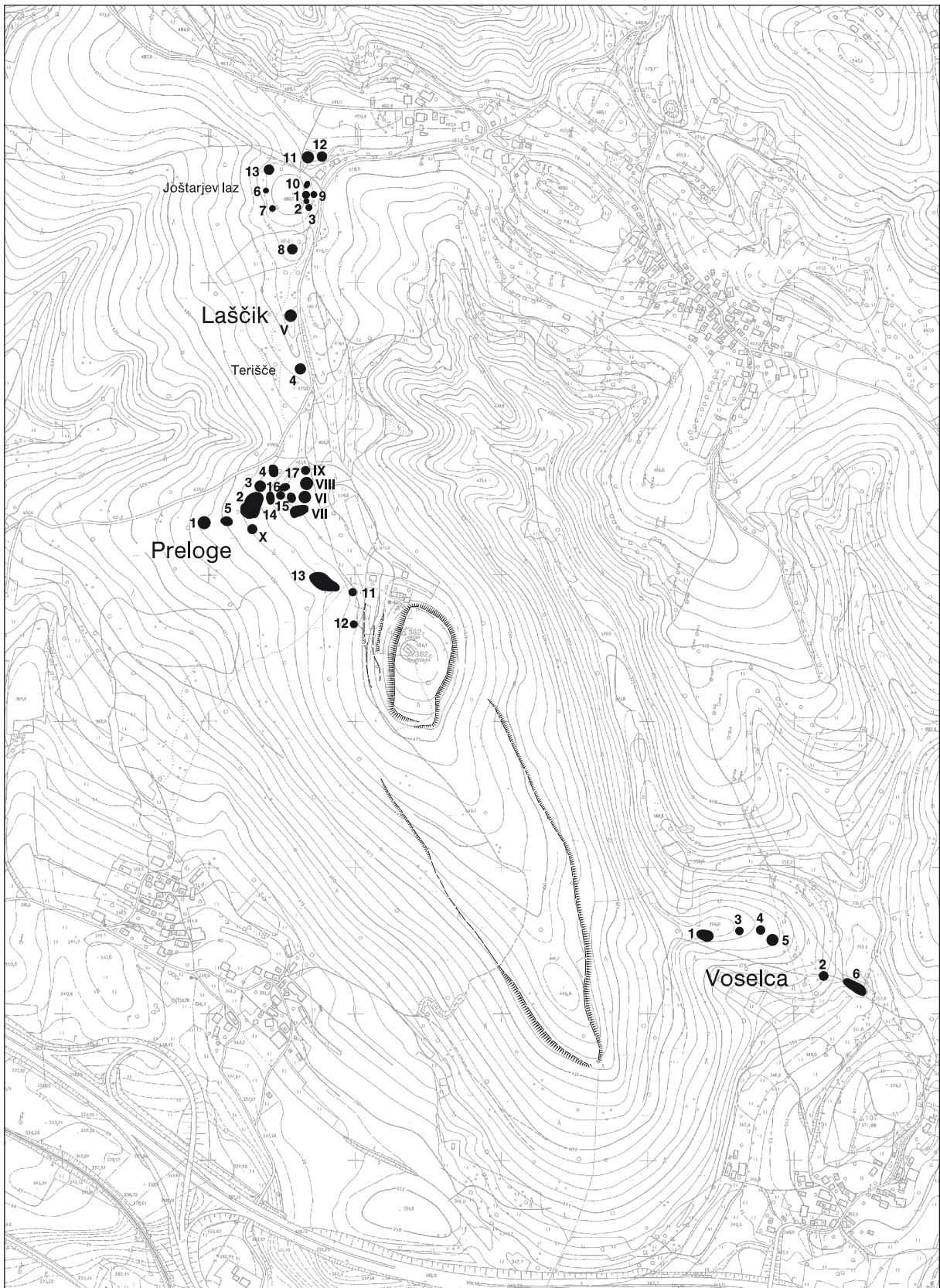

Sl. 1: Naselje in gomile na Magdalenski gori (po Tecco Hvala/Dular/Kocuvan 2004, sl. 4).

Fig. 1: Settlement and tumuli at Magdalenska gora (after Tecco Hvala/Dular/Kocuvan 2004, Abb. 4).

vojvodinje Mecklenburške, ki obsega zapiske njenega pomočnika Gustava Goldberga in izjemno dragocene fotografske posnetke z izkopavanj, je pridobil Peabodyjev muzej Harvardske univerze v ZDA skupaj z najdbami in kartotečnimi listi, ki so nastali ob popisu njene zbirke.⁶

Pomemben vir o odkrivanju tega najdišča predstavljajo tudi objavljene notice in poročila izpod peresa Dežmana in Szombathya v *Mittheilungen der Anthropologischen Gesellschaft*, Rutarja in Črnologarja v *Mittheilungen der Central Commission*, pa tudi Pečnikov in Rutarjevi prispevki v *Izvestjih Muzejskega društva za Kranjsko*.⁷

Prvo kronološko in kulturnozgodovinsko oceno magdalenskogorskih najdb je leta 1915 podal Moritz Hoernes, profesor za prazgodovinsko arheologijo na dunajski univerzi.⁸ Publikacijo arheološke zapuščine vojvodinje Mecklenburške je v sodelovanju s strokovnjaki za evropsko prazgodovino pripravil in uredil Adolf Mahr; znana je kot *Treasures of Carniola* in je izšla leta 1934 v New Yorku. Istega leta je Rajko Ložar napisal prispevek *Predzgodovina Slovenije, posebej Kranjske, v luči zbirke Mecklenburg*, v katerem je objavil predmete iz njene zapuščine, ki jih hrani Narodni muzej Slovenije.⁹ Katalog gradiva z Magdalenske gore v Narodnem muzeju v Ljubljani in v Naravoslovnem muzeju na Dunaju sta pričela pripravljati Stane Gabrovec in Karel Kromer. Gabrovec je v svojih študijah o železni dobi orisal in izpostavil pomen tega arheološkega najdišča ter predstavil reprezentativni izbor predmetov in grobnih celot.¹⁰ Na njegovo pobudo in prizadevanje ter s sodelovanjem Bibe Teržan so bile v začetku osemdesetih let prejšnjega stoletja zrisane in opisane najdbe v dunajskem in ljubljanskem muzeju.

Toda minilo je skoraj stoletje od izkopavanj preden so bile objavljene vse magdalenskogorske izkopanine. Najprej so bili priobčeni rezultati osteoloških analiz živalskih kosti in človeških ostankov iz Mecklenburške zbirke, ki sta jih opravila Sándor Bökönyi in J. Lawrence Angel. Svoji razpravi sta združila v publikaciji *Mecklenburg Collection, Part I, American School of Prehistoric*

documents, held at the Manuscript Collection of the National and University Library (*Narodna in univerzitetna knjižnica*) in Ljubljana. Of particularly great value is the information in the diaries of Franz Brattina and Joseph Szombathy, as well as the correspondence of the latter, all kept at the archives of the museum in Vienna.⁵ Finally, the original documentation of the field campaigns by the Duchess of Mecklenburg, which includes the notes of her secretary Gustav Goldberg and very valuable photos of the excavations, was acquired by the Peabody Museum together with the finds and card files that had been made for the purpose of inventorying her collection.⁶

An important source on the investigations at the site can also be found in the notices and reports written by Deschmann and Szombathy in *Mittheilungen der Anthropologischen Gesellschaft*, by Rutar and Črnologar in *Mittheilungen der Central Commission*, as well as in the articles written by Pečnik and Rutar in *Izvestja Muzejskega društva za Kranjsko*.⁷

The finds from Magdalenska gora were first given a chronological, cultural and historical evaluation in 1915 by Moritz Hoernes, professor of prehistoric archaeology at the University of Vienna.⁸ The finds in the Mecklenburg Collection were first published in 1934 in New York under the title *Treasures of Carniola*, prepared and arranged by Adolf Mahr in collaboration with experts on European prehistory. Also in 1934, Rajko Ložar wrote an article on the prehistory of Slovenia, particularly Carniola, in the light of the Mecklenburg Collection, in which he published the finds from the Duchess' excavations kept at the National Museum of Slovenia.⁹ A catalogue of the material from Magdalenska gora kept both at the National Museum of Slovenia in Ljubljana and the Museum of Natural History in Vienna began to be compiled later by Stane Gabrovec and Karel Kromer. Gabrovec, in his studies of the Iron Age, outlined the archaeological site and emphasized its significance, which included a representative selection of objects and grave groups.¹⁰ It

IX-5, 1882/1459, 1883/2007, 1893/3150, 1893/5019; fond AS 1100, C. kr. spomeniški urad, K 59/191, K 61/18,20,21,24-26,33,34,39-45,49,50,53; fond AS 965, Pečnik Jernej, fasc. 1; NUK: Rokopisni oddelek, Ms 1426, fasc. IX/47-49, 51, 56; NMS: Akcesijska knjiga, št. 1892/187; *Fundaktenarchiv Prähistorische Abteilung NHMW*: J. Szombathy, Tagebuch, Büchlein 33, Brattina, Tagebuch, Büchlein 34.

⁶ Hencken 1978, Fig. 100, 108, 135, 173, 175, 177, 179, 185, 199, 225, 298, Polizzotti Greis 2006, 8, 16, 22, 48; Weiss 1996, Abb. 6.

⁷ Deschmann 1884; Črnologar 1892; Rutar 1893a; *id.* 1893b; *id.* 1893c; *id.* 1893d; Pečnik 1893; Rutar/Pečnik 1894; Rutar 1894; Szombathy 1894; Rutar 1895.

⁸ Hoernes 1915, 98 ss.

⁹ Mahr (ur.) 1934; Ložar 1934.

¹⁰ Gabrovec 1962–1963, 293 ss; *id.* 1964–1965a, 21 ss; *id.* 1964–1965b, 127 ss; *id.* 1965b, 177 ss; *id.* 1966c, 169 ss; *id.* 1975b, 200 s; *id.* 1987, 35 ss *id.*

⁵ *Arhiv Republike Slovenije*: fond AS 38, Deželni zbor in odbor za Kranjsko IX-5; fond AS 1100, C. kr. spomeniški urad, K 59; fond AS 965, Pečnik Jernej, fasc. 1; *Narodna in univerzitetna knjižnica*: Rokopisna zbirka, Ms 1426, fasc. IX; *Narodni muzej Slovenije*: Akcesijska knjiga, št. 1892/187; *Fundaktenarchiv Prähistorische Abteilung, Naturhistorisches Museum Wien*: J. Szombathy, Tagebuch, Büchlein 33, Brattina, Tagebuch, Büchlein 34.

⁶ Hencken 1978, Figs. 100, 108, 135, 173, 175, 177, 179, 185, 199, 225, 298, Polizzotti Greis 2006, 8, 16, 22, 48; Weiss 1996, Abb. 6.

⁷ Deschmann 1884; Črnologar 1892; Rutar 1893a; *id.* 1893b; *id.* 1893c; *id.* 1893d; Pečnik 1893; Rutar/Pečnik 1894; Rutar 1894; Szombathy 1894; Rutar 1895.

⁸ Hoernes 1915, 98 ff.

⁹ Mahr (ed.) 1934; Ložar 1934.

¹⁰ Gabrovec 1962–1963, 293 ff; *id.* 1964–1965a, 21 ff; *id.* 1964–1965b, 127 ff; *id.* 1965b, 177 ff; 1966c, 169 ff; *id.* 1975b, 200 f; *id.* 1987, 35 ff etc.

Research, Peabody Museum, Harvard University, Bulletin 25, 1968. Desetletje kasneje ji je sledil drugi del z objavo kataloga grobov in najdb, ki jo je pripravil Hugh Hencken ob uredniški pomoči Petra S. Wellsa. To monografsko delo z naslovom *The Iron Age Cemetery of Magdalenska gora in Slovenia, Mecklenburg Collection, Part II, American School of Prehistoric Research, Peabody Museum, Harvard University, Bulletin* 32, 1978, vključuje še analizo ostankov tkanine na kovinskih predmetih ter analizo grafitna na lončenini. Nazadnje je luč sveta v tiskani obliki zagledalo tudi gradivo iz Narodnega muzeja Slovenije in Naravoslovnega muzeja na Dunaju. Objavo smo pripravili Sneža Tecco Hvala, Janez Dular in Eva Kocuvan, izšla pa je leta 2004 z naslovom *Železnodobne gomile na Magdalenski gori (Eisenzeitliche Grabhügel auf der Magdalenska gora)* kot 36. zvezek v seriji Katalogov in monografij, ki jih izdaja Narodni muzej Slovenije. V njem je podrobneje predstavljena zgodovina raziskovanj, na novo je ovrednotena tudi topografska situacija arheoloških ostalin na Magdalenski gori s pomočjo zbranih arhivskih virov in dokumentov, ki so integralno vključeni. Omenjena dela predstavljajo osnovo za to razpravo, poleg temeljnih študij starejše železne dobe v jugovzhodnih Alpah, zlasti razprav Gabrovca in Teržanove, ki sta utemeljila kronološko shemo dolenske halštatske skupnosti in postavila izhodišča za študij kulturnih značilnosti, družbene strukture in družbenih vlog.

Da bi si lažje ustvarili nazorno predstavo o potencialu primarnih virov, ki jih imamo na voljo za preučevanje železnodobne skupnosti na Magdalenski gori, si fonde oglejmo v kontekstu poteka raziskav.

1.1.1 NAJDBE

NAJDBE V NARODNEM MUZEJU SLOVENIJE

V Narodnem muzeju Slovenije je evidentiranih 491 predmetov (*sl. 2*) iz prvih kopanj na Magdalenski gori, ki so potekala v času, ko je bila slovenska arheologija šele v zametkih, kar se je razumljivo odrazilo tudi v načinu kopanja in dokumentiranja, ki je z današnjega zornega kota precej pomanjkljivo. Razen tega so najdbe v muzeju inventarizirane v okviru najdišč po tipološkem principu brez grobnih oznak; zavedene so pod številkami P 2943-2997, 3956-4310, 4325-4330, 7103, 11698-11760, 13304. V celoti so bile objavljene šele leta 2004.¹¹ Po tej objavi povzemam tudi zgodovino raziskovanj. Na podlagiotic o izkopavanjih in redkih fotografij je bilo moč prepoznati nekatere izjemne kose ter delno rekonstruirati 18 grobnih celot in dva skupka predmetov. V naši objavi so označene z ledinskim imenom, številko gomile ali letni-

¹¹ Tecco Hvala/Dular/Kocuvan 2004, T. 1, 2 A, 2 B, 3 B, 3 C, 4, 5 A, 6 B, 7-14, 143-145, 146: 1-5, 7-10, 16-18, 25, 26, 31, 32, 147-151, 152: 1-8, 10-13, 15-22, 153-170, 171: 1, 172, 173.

was also his incentive and efforts – in collaboration with Biba Teržan – that led to the finds kept in the museums in Vienna and Ljubljana to be drawn and described in the early 1980s.

Having said that, the integral publication of the finds from Magdalenska gora came almost a century after they had been unearthed. The first to be published were the results of osteological analyses of animal bones and human remains from the Mecklenburg Collection, conducted by Sándor Bökönyi and J. Lawrence Angel, respectively, in *Mecklenburg Collection, Part I, American School of Prehistoric Research, Peabody Museum, Harvard University, Bulletin* 25, 1968. A decade later came *Part II*, containing the catalogue of graves and finds compiled by Hugh Hencken with the editorial aid by Peter S. Wells, under the title of *The Iron Age Cemetery of Magdalenska gora in Slovenia, Mecklenburg Collection, Part II, American School of Prehistoric Research, Peabody Museum, Harvard University, Bulletin* 32, 1978. This monographic publication further includes the analysis of the textiles remains adhered to metal objects and the analysis of the graphite on ceramic vessels. Published last was the material kept at the National Museum of Slovenia and Natural History Museum in Vienna – by Sneža Tecco Hvala, Janez Dular and Eva Kocuvan in 2004 under the title *Železnodobne gomile na Magdalenski gori (Eisenzeitliche Grabhügel auf der Magdalenska gora)*, as Volume 36 of the *Catalogi et monographiae* series of the National Museum of Slovenia. This publication brought a detailed history of research as well as a new evaluation of the topographic situation of the archaeological remains at Magdalenska gora on the basis of archival sources and documents, all of them integrally included in the book. The publications mentioned above, focusing on Magdalenska gora, represent an important basis for the analyses and discussions in this book; the other being the basic studies on the Iron Age in the South-Eastern Alps, particularly those written by Gabrovca and Teržan, who established the chronological outline of the Dolenska Hallstatt community and set points of departure for the study of cultural characteristics, as well as social structure and role of the said community.

In order to present more clearly the potential and scope of the primary sources available for the study of the Iron Age community from Magdalenska gora, these will be presented below within the context of the course of research.

1.1.1 FINDS

FINDS IN THE NATIONAL MUSEUM OF SLOVENIA

The National Museum of Slovenia keeps 491 objects (*fig. 2*) from the first excavation campaigns at Magdalenska gora. These took place in the time when Slovene

Muzej / Museum	Št. grobnih celot No. of grave groups	Št. predmetov No. of objects
Narodni muzej Slovenije, Ljubljana	20	622
Naturhistorisches Museum, Wien	266	1635
Peabody Museum, Harvard University, Cambridge, Massachusetts	370	1258
Skupaj / Total	656	3515

Sl. 2: Število grobnih celot in predmetov oz. skupkov predmetov z Magdalenske gore po muzejih.

Fig. 2: Number of grave groups and objects or sets of objects from Magdalenska gora kept at different museums.

co odkritja ter s črko ali številko groba oz. skupka najdb za poševnico (npr. Preloge 2/p, Laščik 1892/6, Voselca 6/skupek 1). V Narodnem muzeju Slovenije je še 131 predmetov z izkopavanj vojvodinje Mecklenburške, ki so označeni s številkami P 6763-6810, 6813, 6816-6817, 6887, 6919-6921, 6937, 11802-11878; prvi jih je objavil Ložar in pozneje še Hencken.¹²

V Deželnem muzeju za Kranjsko – predhodniku Narodnega muzeja Slovenije v Ljubljani – so se odločili pregledati neposredno okolico Magdalenske gore po tistem, ko se je razvedelo, da so kmetje pri kopanju peska ob poti v Zgornjo Slivnico naleteli na starine, ki so jih pozimi leta 1881/82 prodali lokalnemu zbiratelju Valentinu Sadnikarju. Muzejski preparator Ferdinand Schulz je zato leta 1882 opravil v šestih dneh več sondiranj na severnem delu nekropole, ki se širi na pašniku Laščik od ledine Terišče na južnem koncu do Joštarjevega laza na skrajnem severnem robu (sl. 1). Najprej si je ogledal vkop, ki so ga za sabo pustili kmetje in tam našel razmetane kosti in črepinje posod, nato se je lotil ene izmed bližnjih gomil (Laščik, gomila 9),¹³ v kateri je odkril en skeletni in dva žarna grobova ter več ostankov človeških kosti po vsej gomili. Načel je tudi veliko gomilo na Terišču (gomila 4), kjer je izkopal dva skeletna in en žarni grob ter še nekaj bronastih predmetov brez prepoznanih kontekstov. Istega leta sta si z Dragotinom Dežmanom, ki je bil takrat na čelu Deželnega muzeja, ogledala tudi jugovzhodno gomilno grobišče na ledini Voselca pri Hrastju. Tam je v največji gomili (gomila 6) aprila 1882

¹² Ložar 1934, 10 ss, T. 1: 3-7, 2, 3; 4: 1-6; Hencken 1978, Fig. 7a, 32, 40, 58, 61, 85, 86, 100, 102, 108, 115, 118, 120, 131, 132, 135, 147-149, 171, 173, 175, 177, 179, 185, 193, 225, 242, 244, 258, 260, 271, 287, 289, 298, 309, 311, 316, 325, 340, 342, 356.

¹³ V nadaljevanju navajam v oklepaju številko gomile, ki jo ima na sl. 1.

archaeology was only in its infancy, which is naturally reflected in the method of excavation and documentation, both wanting from the modern perspective. A further problem is that these museum finds are inventoried typologically within a particular site, without their grave provenance being marked. The finds from Magdalenska gora can be found under the numbers P 2943-2997, 3956-4310, 4325-4330, 7103, 11698-11760, 13304 and were integrally published in 2004.¹¹ Among these, certain exceptional objects could be identified on the basis of newspaper notices on the excavations and rare photographs, which allowed for 18 grave groups and two other sets of objects to be partly reconstructed. These graves are marked here with the name of the fallow where they were found, tumulus number or year of discovery and, following a slash, the letter or number of the grave or set of finds (for example Preloge 2/p, Laščik 1892/6, Voselca 6/Set 1). Besides these finds, the museum in Ljubljana keeps further 131 objects from the excavations of the Duchess of Mecklenburg marked as P 6763-6810, 6813, 6816-6817, 6887, 6919-6921, 6937, 11802-11878, first published by Ložar and later also by Hencken.¹²

After hearing of farmers finding antiquities while digging for gravel along the road to Zgornja Slivnica, which were sold to Valentin Sadnikar, a local antique collector, in the winter of 1881/82, the Provincial Museum for Carniola (*Krainisches Landesmuseum – Rudolfinum*) – predecessor of the National Museum of Slovenia in Ljubljana – decided to survey the immediate vicinity of Magdalenska gora. It was Ferdinand Schulz, museum technician, who conducted several trenching campaigns within six days of 1882, in the northern part of the cemetery on the pasture named Laščik, from the Terišče fallow in the south to Joštarjev laz on the northernmost edge (fig. 1). He first inspected the hole dug by the farmers and found scattered bones and pottery shards. He proceeded to investigate one of the nearby tumuli (Laščik, Tumulus 9),¹³ in which he found one inhumation and two cremation graves as well as human bone remains scattered across the surface of the tumulus. He also began investigating the large tumulus at Terišče (Tumulus 4), where he excavated two inhumations and one cremation grave as well as several bronze objects without clear contexts. In the same year, he and Deschmann, head of the museum in Ljubljana at the time, inspected the south-eastern tumulus cemetery on the Voselca fallow near Hrastje. In

¹¹ Tecco Hvala/Dular/Kocuvan 2004, T. 1, 2 A, 2 B, 3 B, 3 C, 4, 5 A, 6 B, 7-14, 143-145, 146: 1-5,7-10,16-18,25,26,31,32, 147-151, 152: 1-8,10-13,15-22, 153-170, 171: 1, 172, 173.

¹² Ložar 1934, 10 ff, T. 1: 3-7, 2, 3; 4: 1-6; Hencken 1978, Figs. 7a, 32, 40, 58, 61, 85, 86, 100, 102, 108, 115, 118, 120, 131, 132, 135, 147-149, 171, 173, 175, 177, 179, 185, 193, 225, 242, 244, 258, 260, 271, 287, 289, 298, 309, 311, 316, 325, 340, 342, 356.

¹³ The tumulus number within brackets corresponds to that on fig. 1.

nek domačin pri kopanju zemlje zadel na glinasto situlo. Schulz je zatem gomilo na dveh mestih poskusno načel, bolj obsežno pa jo pričel kopati v mesecu avgustu. Zaradi slabih vremenskih razmer in po smrti nezgodi enega izmed kopačev je delo prekinil in jo dokončno prekopal naslednjo pomlad, v njej je zabeležil vsega skupaj pet skupkov predmetov. Tri dni je posvetil tudi višje ležeči gomili (gomila 5), kjer je izkopal nekaj sporadičnih najdb. Leta 1884 se je Schulz vnovič usmeril na Laščik in odprl še eno gomilo, v kateri ni odkril ničesar. Kopali so menda tudi nekje ob poti k cerkvi in našli več žar z žganino ter nekaj pridatki.¹⁴

Odtlej so izkopavanja na Magdalenski gori zastala vse do leta 1892, ko je ob podpori dunajske Centralne komisije delo zastavil arheološki samouk Jernej Pečnik. Začel je na rahli vzpetini na severnem koncu Laščika (na gomili 8), kjer so menda že leta 1870 pri krčenju gozda našli več zapestnic in ogrlic ter baje celo rimski srebrnik, vendar ti predmeti niso ohranjeni. Pečnik je tistikrat odkril tri žgane grobove, v istem letu pa je na Laščiku izkopal še petnajst grobov. V jeseni je načel tudi dve največji gomili za Joštarjevo hišo (gomili 11 in 12), toda brez zelenega uspeha, zato se je premaknil na lokacijo bližje naselju.

Na Prelogah je preizkušal srečo na treh manjših gomilah (gomile 5, 6 in 8), a je bila bera bolj pičla. V gomili 5 je našel skelet in zdrobljeno bronasto posodo s pokrovom, pasno spono z obročki, železno orožje, fibulo ter uhane, v gomili 8 pa dva žgana grobova; kaj je našel v gomili 6, ni znano. Gomili 6 in 8 je za njim dokončno raziskala vojvodinja Mecklenburška. Bolj obetavno se je začelo kopanje oktobra 1892, ko je Pečnik v največji gomili iz te gruč (gomila 2) že takoj na začetku naletel na več grobov. Nadaljeval je v decembru, resneje pa se je je lotil februarja 1893. Odpiral jo je frontalno od severa proti jugu. Izkop je nadziral konservator Centralne komisije, Simon Rutar, v njegovi odsotnosti pa korespondent te komisije, Konrad Črnologar. Februarja 1893 je sondiral tudi sosednjo gomilo (gomila 3), v kateri je odkril tri žarne grobove, obdane s kamni. Najdbe je pošiljal Deželnemu muzeju v Ljubljani. Ker zanje ni prejel težko pričakovane kupnine, se je obrnil na dvorni muzej na Dunaju, ki ga je bil pripravljen denarno podpreti. Datum 15. april 1893 predstavlja nekakšno prelomnico, kajti poslej so vse izkopanine odšle na Dunaj. Še pred tem, najverjetneje v aprilu 1893, se je Pečnik vrnil k velikima gomilama za Joštarjevo hišo (gomili 11 in 12), ki ju je načel leto poprej. Tokrat je v vsaki odkril po en žarni grob, pridatke pa poslal v Ljubljano.¹⁵

Narodni muzej hrani le manjši delež najdb, ki so bile izkopane na Magdalenski gori. Zdi se, da tedanji politiki in ustanove v Ljubljani niso imeli zadostnega vpliva ali pa se morda niso zavzeli dovolj za to, da bi

the largest tumulus of the cemetery (Tumulus 6), a local man reportedly hit upon a clay situla in April 1882. Schulz first dug test pits in two places of the tumulus, while more extensive excavation was conducted in August. He interrupted the excavation due to bad weather conditions and the death of one of the diggers. He finished investigating the tumulus next spring, altogether recording five sets of objects in the tumulus. Schulz consecrated three days to a tumulus further uphill (Tumulus 5), where he dug up several individual finds. In 1884, he again excavated at Laščik, opening another tumulus, which he found to be empty. Further digging was reportedly done along the path leading to the church, revealing several urns with burnt remains and grave goods.¹⁴

Excavation at Magdalenska gora was resumed in 1892, when Jernej Pečnik, a self-taught archaeologist from Dolenjska, began digging with the support by the Viennese Central Commission. He started on a slightly elevated area on the northern end of Laščik (Tumulus 8), where several now unpreserved bracelets and necklaces, even a Roman silver coin, had presumably been found in 1870. Pečnik found three cremation graves and further fifteen graves in the same year at Laščik. In the autumn, he began digging two largest tumuli behind Joštar's house (Tumuli 11 and 12). Excavations not producing the desired results, he moved to a location closer to the settlement.

Pečnik tried his luck on three smaller tumuli at Preloge (Tumuli 5, 6 and 8), though finds were scarce. Tumulus 5 revealed a skeleton and a broken bronze vessel with a lid, belt buckle with rings, iron weapons, a fibula and earrings. Tumulus 8 revealed two cremation graves, while the contents of Tumulus 6 are unknown; the latter two tumuli were investigated later also by the Duchess of Mecklenburg. More promising excavation for Pečnik began in October 1892, when he began digging Tumulus 2, the largest of the group, and came across several graves at the very beginning. He resumed work in December, though more serious work began in February 1893. Pečnik dug the tumulus frontally from north to south. Excavation was supervised by the curator at the Central Commission, Simon Rutar, and in his absence, Konrad Črnologar, correspondent of the said commission. In February 1893, Pečnik also test-pitted the adjacent tumulus (Tumulus 3), which revealed three cremation graves encircled by stones. At first, he was sending the finds to the museum in Ljubljana. Not receiving the much-needed purchase money, however, he turned to the museum in Vienna, which was prepared to financially support his efforts. Thus, after 15 April 1892 all finds went to Vienna. Just before that date, most probably in April 1893, Pečnik again dug the large tumuli behind Joštar's house (Tumuli 11 and 12). He found a cremation grave in each and sent the finds to Ljubljana.¹⁵

¹⁴ Tecco Hvala/Dular/Kocuvan 2004, 17 ss ter 81 in 88, z navedeno literaturo in arhivskimi viri; glej še Vuga 2006, 226.

¹⁵ Tecco Hvala/Dular/Kocuvan 2004, 20 ss.

¹⁴ Tecco Hvala/Dular/Kocuvan 2004, 17 ff and 81, 88 with references; see also Vuga 2006, 226.

¹⁵ Tecco Hvala/Dular/Kocuvan 2004, 120 ff.

izkopanine ostale na domačih tleh; tako je večji del gradiva (med drugim tudi izjemni primerki) pristal v tujih muzejih.¹⁶ Na drugi strani pa potek izkopavanj in ohranjen dokumentacija kaže, da se jih niso lotili ravno sistematično in tudi dokumentirali so jih precej slabo, zato ponuja ta fond za analizo družbene strukture bolj malo možnosti.

NAJDBE V NARAVOSLOVNEM MUZEJU NA DUNAJU

Na Dunaj so v Naravoslovni muzej romale najdbe z izkopavanj v letih 1893 in 1894, razen tega so odkupili predmete od zbiratelja Sadnikarja, ki jih je ta pridobil od kmetov pozimi 1881/82 (gre za pridatke enega groba in nekaj sporadičnih najdb). Od Centralne komisije so prejeli serijo steklenih in jantarnih jagod ter nekaj bronastih pasnih okovov in obeskov, ki jih je Pečnik izkopal med januarjem in marcem 1893 v gomili 2 na Prelogah ter predal tej komisiji. Najdbe so inventarizirane po grobnih celotah, gre za 266 enot. Vsebovale so okoli 1635 predmetov (*sl. 2*), ki so označeni s številkami 6828-6834, 21721-22109, 22605-23090, 27342-28058, 28419-28422, 55454-55494, 86601-86755, 86772. V kataloški obliki so predstavljene skupaj s prepisi arhivskih virov v isti publikaciji kot predmeti iz Narodnega muzeja Slovenije.¹⁷

Kot je znano, se je sodelovanje dunajskega muzeja z dolenskim starinokopom Pečnikom začelo v sredini aprila 1893, ki je odtlej ravnal po navodilih vodje Antropološko-prazgodovinske zbirke Josefa Szombathyja in najdbe opremljal s podatki o grobovih.¹⁸

Marca 1893 je poskusno zakopal v veliko gomilo na Prelogah, ki leži blizu naselbine (gomila 13), in pri tem zadel na bronast kotliček in pasno spono. Tisto leto je maja z vrha načel tudi gomilo na jugovzhodnem grobišču na ledini Voselca pri Hrastju (gomila 1), kjer so domačini že večkrat našli staro orožje, o čemer poroča Dežman. Pečnik je tam naletel na ženski in moški grob, nato pa je delo na njej opustil. Junija 1893 je prekopal še eno gomilo na Voselci – gomilo 2 s 25 grobovi. Avgusta se je znova lotil gomile 8 na severnem grobišču, na ledini Joštarjev laz, v kateri je leto poprej odkril tri grobove in najdbe predal Deželnemu muzeju v Ljubljani. Tokrat je v njej našel še en grob, pridatke pa poslal na Dunaj. Dunajskemu muzeju je izročil tudi predmete dveh drugih grobov, ki jih je izkopal na Laščiku.

Sredi marca 1894 je zaključil z delom na največji gomili na Prelogah (gomila 2), ki naj bi po njegovi oceni vsebovala skupno okoli 400 grobov. Skorajda vse, kar je

The National Museum of Slovenia keeps only a small part of the finds excavated at Magdalenska gora. It seems that the politicians and institutions of the time did not carry enough clout, or possibly did not muster up the enthusiasm for keeping the finds in the province. Most of the material – among them also exceptional pieces – thus ended up in foreign museums.¹⁶ Moreover, the way the finds were excavated and the surviving documentation of the excavation show that the latter had not been undertaken very systematically nor had it been well documented. For that reason, the material kept in Ljubljana offers only limited possibilities for the study of the social structure at Magdalenska gora.

FINDS IN THE NATURAL HISTORY MUSEUM IN VIENNA

The finds excavated in 1893 and 1894 were being sent to the Viennese Museum of Natural History. Apart from those, the museum purchased finds constituting the goods of one grave and some individual finds from the collector Sadnikar, who obtained them from a farmer in the winter of 1881/82, as mentioned above. Furthermore, the museum received a series of glass and amber beads as well as several bronze belt fittings and pendants from the Central Commission, which obtained them from Pečnik who had found these objects in Tumulus 2 at Preloge between January and March 1893. All the finds from Magdalenska gora at the museum were inventoried according to grave groups, altogether 266 of them (*fig. 2*), consisting of approximately 1635 objects marked with the following numbers: 6828-6834, 21721-22109, 22605-23090, 27342-28058, 28419-28422, 55454-55494, 86601-86755, 86772. The finds were compiled in a catalogue, together with the transcripts of archival sources, in the same publication as the finds kept at the National Museum of Slovenia.¹⁷

As stated above, the collaboration between the museum in Vienna and Pečnik began in the middle of April 1893. From that time onwards, Pečnik adhered to the instructions given to him by Joseph Szombathy, head of the Anthropological and Prehistoric Collection at the museum, and equipped the finds with burial data.¹⁸

In March 1893, Pečnik test-pitted in a large tumulus at Preloge near the settlement (Tumulus 13), and found a bronze pot and a belt buckle. In May of the same year, he began digging another tumulus, starting at its top (Tumulus 1), in the south-eastern cemetery on the Voselca fallow near Hrastje, where local people had

¹⁶ Ložar 1934, 6 ss; Gabrovec 1978, 138 ss; Dular J. 2003, 59 ss; Gabrovec 2008, 28 ss; Dular J. 2009a.

¹⁷ Tecco Hvala/Dular/Kocuvan 2004, T. 2 C, 3 A, 5 B, 6 A, 15-142, 146: 6,11-15,19-24,27-30, 152: 9,14.

¹⁸ Dular J. 2003, sl. 47.

¹⁶ Ložar 1934, 6 ff; Gabrovec 1978, 138 ff; Dular J. 2003, 59 ff; Gabrovec 2008, 28 ff; Dular J. 2009a.

¹⁷ Tecco Hvala/Dular/Kocuvan 2004, T. 2 C, 3 A, 5 B, 6 A, 15-142, 146: 6,11-15,19-24,27-30, 152: 9,14.

¹⁸ Dular J. 2003, Abb. 47.

našel v tej gomili od oktobra 1892 do sredine aprila 1893, je v tipološko urejeni zbirki muzeja v Ljubljani, kasneje odkrite izkopanine pa hrani dunajski muzej, kjer so inventarizirane po grobnih celotah – gre za pridatke iz 88 grobov in nekaj sporadičnih najdb. Na začetku jeseni je Szombathy organiziral sistematično raziskovanje gomile 13 na Prelogah, ki je trajalo od 18. septembra do 15. novembra 1894. Ob pomoči preparatorja dunajskega muzeja Franza Brattine, ki je skrbel za dokumentacijo in najdbe, je Pečnik spraval na dan 149 grobnih celot in 24 grobov brez pridakov.

V letu 1905 je Pečnik na lastno pest izkopal tri grobove v gomili 4 na Prelogah in gradivo poslal dunajskemu muzeju z upanjem, da mu bodo naklonili kakšen zaslužek, vendar mu denarja za nadaljevanje izkopavanja niso odobrili. Izkop gomile je nato dokončala vojvodinja Mecklenburška.¹⁹

Gradivo v dunajskem Naravoslovnem muzeju predstavlja najdragocenejši in najzanesljivejši vir podatkov za nadaljnje analize. Najdbe so ohranjene po grobnih celotah, v muzej so prišle skupaj s sezname in opisi kontekstov neposredno po izkopavanju, ki je bilo sistematično zastavljeno in za tisti čas dokaj natančno dokumentirano. To velja zlasti za gomilo 13 na Prelogah, saj smo lahko na osnovi zabeleženih merskih podatkov rekonstruirali tlorisni načrt gomile z lego grobov, ohranjena pa je tudi skica preseka gomile.²⁰

NAJDBE V PEABODYJEVEM MUZEJU

Večji del najdb iz zbirke vojvodinje Mecklenburške je zaključil svojo pot v ameriški zvezni državi Massachusetts v Peabodyjevem muzeju Harvardske univerze v Cambridgeu. Z Magdalenske gore je evidentiranih približno 355 do 370 grobov s skupno 1258 predmeti (sl. 2), ki jih je objavil Hencken, vključno s povzetki Goldbergovih opisov.²¹

Vojvodinja Mecklenburška je v letih od 1905 do 1913 na Magdalenski gori prekopala deset gomil ob pomoči svojega tajnika Gustava Goldberga, ki je izkopavanja dokumentiral. Maja 1905 je načela eno izmed gomil na Prelogah, h kateri se je vrnila še v oktobru istega leta in maja 1908. V aprilu in maju 1906 je prekopala še drugo gomilo na tej ledini, potem pa je delo na tem najdišču za dve leti prekinila. Nadaljevala je leta 1908, ko je od maja

been finding old weapons, as reported by Deschmann. Pečnik found a female and a male grave, after which he ceased digging there. He moved to another tumulus at Voselca (Tumulus 2) in June 1893, which contained 25 graves. In August, he again dug a tumulus in the northern cemetery, on the Joštarjev laz fallow (Tumulus 8), where he had found three graves a year earlier, the contents of which went to the museum in Ljubljana. On this occasion, he found another grave and sent the goods to Vienna. He also delivered to the museum the objects from two other graves excavated at Laščik.

In mid-March 1894, Pečnik finished excavating the largest tumulus at Preloge (Tumulus 2), which by his estimation contained roughly 400 graves. Almost all of the finds excavated there from October 1892 to April 1893 are kept typologically arranged in the museum in Ljubljana, while the finds unearthed later are held at the museum in Vienna and inventoried according to graves. The latter comprise 88 grave groups and several individual finds. Later, from 18 September to 15 November 1894, Szombathy organized a systematic investigation of Tumulus 13 at Preloge. Aided by Franz Brattina, museum technician at the Viennese museum, who was in charge of documentation and finds, Pečnik unearthed 149 grave groups and further 24 graves without grave goods.

Pečnik again excavated in 1905, on his own initiative, unearthing three graves in Tumulus 4 at Preloge and sent the material to Vienna in hope of earning money. However, the museum did not grant him means for further excavation. The excavation of the tumulus was later finished by the Duchess of Mecklenburg.¹⁹

The material kept at the Natural History Museum in Vienna represents the most valuable and reliable source of information for further analyses. The finds there are kept according to graves and came to the museum equipped with lists and descriptions of the find context, which had been conceived systematically and documented quite accurately. This is particularly true of Tumulus 13, for which a ground-plan with the position of graves could be reconstructed on the basis of measurements noted in the documentation, while a sketch of the tumulus' cross-section has also been preserved.²⁰

FINDS IN THE PEABODY MUSEUM

Most of the finds unearthed by the Duchess of Mecklenburg ended their journey in the USA, in the Peabody Museum of Harvard University in Cambridge, Massachusetts. The Peabody Museum keeps records of roughly 355 to 370 graves containing 1258 finds from

¹⁹ Tecco Hvala/Dular/Kocuvan 2004, 20 s, 26, 50, 52 s, 81 ss.

²⁰ Ibid., sl. 27 in 28.

²¹ Mahr 1934, 27; Ložar 1934, 10 ss; Gabrovec 1975b; Hencken 1978; Dobiat 1982, 32; Polizzotti Greis 2006, 10, 16, 22, 48, 58, 85, 87, 89, 91, 94, 95, 97, 99–103, 105. Fotografije predmetov so dostopne tudi na spletnem naslovu muzeja: <http://www.peabody.harvard.edu/node/39>.

¹⁹ Tecco Hvala/Dular/Kocuvan 2004, 120 f, 124 f, 140 f, 142 f, 164 ff.

²⁰ Ibid., Abb. 27 and 28.

do julija preiskala dve gomili. Vnovič se je kopanja na Magdalenski gori lotila leta 1913. V tej zadnji kampanji, ki je trajala neprekinjeno od julija do konca septembra, je raziskala pet gomil na ledini Preloge ter veliko gomilo na osrednjem delu Laščika (gomila V). Zavidljivo raven njenih izkopavanj so ji priznavali nekateri tedanji ugledni evropski arheologi, kot sta Oskar Montelius in Joseph Déchelette, ki sta si njeno delo ogledala na terenu.²²

Arheološko udejstvovanje vojvodinje in usoda njene zbirke sta opisana v mnogih prispevkih, nazadnje je odisejado njene zapuščine osvetlil in dopolnil še z nekaterimi dejstvi Janez Dular.²³ V njih lahko preberemo, da je v času političnih sprememb leta 1919 njena zbirka zapadla pod sekvester in je bil nad njo uveden državni nadzor. Leta 1924 so jo na predlog sorodnika vojvodinje začasno prenesli iz gradu Bogenšperk pri Litiji v muzej v Ljubljano; ona se je namreč pred tem za stalno odselila na Mecklenburško. Državno skrbstvo nad njenim premoženjem je bilo leta 1928 preklicano in zbirka je tako znova prešla v njeno last. Po smrti vojvodinje (umrla je 9. julija 1929) sta jo podedovala njena potomca. Hči, Marie Antoinette, je leta 1932 dosegla, da so zbirko iz ljubljanskega muzeja prepeljali na njen dom na Bledu. Tistikrat je ostal en zaboj z najdbami v muzeju, ker so ga spregledali. Marie Antoinette je bila tedaj že trdno odločena, da materino zapuščino proda. Nazadnje se ji je ponudila možnost avkcijske prodaje s posredovanjem American Art Association Anderson Galleries. Pred prodajo je dovolila, da je muzej v Ljubljani odbral nekaj predmetov v spomin na njeno mater. Leta 1933 je zbirka romala v Zürich, kjer so jo uredili, popisali in za objavo pripravili vrhunski znanstveniki za evropsko prazgodovino. V publikaciji, ki je izšla 1934, je magdalenskogorsko nekropolo predstavil Raymond Lantier, tedanji direktor ustanove Musée des Antiquités Nationales v St. Germain-en-Laye.²⁴

Dražba, ki je bila januarja 1934 v New Yorku, ni uspela. Zaradi splošne gospodarske krize zainteresirani muzeji za odkup niso zbrali dovolj sredstev, na srečo pa tudi pri ljubiteljih starin ni doživela odziva. Po kosih sta jo nato odkupila britanski Ashmolean Museum v Oxfordu in ameriški Peabody Museum v Cambridgeu. Magdalenskogorske najdbe so z dokumentacijo vred pristale v Peabodyjevem muzeju Harvardske univerze, za kar si je zelo prizadeval Hugh Hencken.

Dogajanje z zbirko, preden je našla svoje stalno mesto v muzeju, je nedvomno vplivalo na zanesljivost ohranjenih kontekstov.²⁵ Vojvodinja je gradivo z raz-

Magdalenska gora (*fig. 2*), which were published by Hencken together with the summaries of Goldberg's descriptions.²¹

The Duchess of Mecklenburg excavated ten tumuli at Magdalenska gora from 1905 to 1913, with the aid of her secretary, Gustav Goldberg, who documented the excavation. In May 1905, she began digging one of the tumuli at Preloge, to which she returned in October of the same year and again in May 1908. In April and May 1906, she excavated the second tumulus at Preloge. After a two-year pause, she resumed excavation in 1908 by investigating two tumuli from May to July. Her last campaign at Magdalenska gora was in 1913, which took place uninterruptedly from July to the end of September. She excavated five tumuli at Preloge as well as a large tumulus in the central part of Laščik (Tumulus V). Her excavations were conducted at a level that astonished even reputable European archaeologists such as Oscar Montelius and Joseph Déchelette, who came to inspect her fieldwork.²²

The archaeological activity of the Duchess and the fate of her archaeological collection is the subject of numerous articles, with the last one to shed light on the odyssey of her finds and to supplement it with certain facts being written by Janez Dular.²³ These articles reveal that in the time of the political changes of 1919 her collection was sequestered and placed in state custody. In 1924, it was temporarily moved from Bogenšperk Castle to the museum in Ljubljana on the suggestion of a relative of the Duchess; she had prior to that moved her permanent residence to Mecklenburg in Germany. The state custody of her property was revoked in 1928 and the collection again came into her possession. The Duchess died on 9 July 1929, with her collection inherited by her two children. The daughter, Marie Antoinette, succeeded in 1932 in having the collection transferred from the museum in Ljubljana to her home in Bled. During the transfer, one of the packing cases was overlooked and thus remained in the museum. Marie Antoinette was already at that time firmly intent on selling her mother's legacy. Finally, she had the opportunity to sell the collection at an auction with the mediation of the American Art Association Anderson Galleries. Prior to the auction, she allowed the museum in Ljubljana to choose several objects in memory of her

²² Mahr 1934, 2; Lantier 1934, 39, op. 1; Polizzotti Greis 2006, 40 ss; Dular J. 2009a, op. 50.

²³ Mahr (ur.) 1934; Ložar 1934; Hencken 1968b; *id.* 1978, 1 s; Gabrovec 1978; Dobiat 1982; Weiss 1999; Polizzotti Greis 2006; Gabrovec 2008, 19 ss; Dular J. 2009a.

²⁴ Lantier 1934.

²⁵ Hencken 1978, 2; Weiss 1996; Gabrovec 2008, 19 ss; Dular J. 2009a; Božič 2009.

²¹ Mahr 1934, 27; Ložar 1934, 10 ff; Gabrovec 1975b; Hencken 1978; Dobiat 1982, 32; Polizzotti Greis 2006, 10, 16, 22, 48, 58, 85, 87, 89, 91, 94, 95, 97, 99–103, 105. The photographs of objects are accessible also on the web: <http://www.peabody.harvard.edu/node/39>.

²² Mahr 1934, 2; Lantier 1934, 39, n. 1; Polizzotti Greis 2006, 40 ff; Dular J. 2009a, n. 50.

²³ Mahr (ed.) 1934; Ložar 1934; Hencken 1968b; *id.* 1978, 1 f; Gabrovec 1978; Dobiat 1982; Weiss 1999; Polizzotti Greis 2006; Gabrovec 2008, 19 ff; Dular J. 2009a.

ličnih najdišč hranila skupaj v treh sobanah na svojem gradu. Pogled v njene prostore, ki se je avgusta 1919 odstrl ravnatelju Deželnega muzeja Josipu Mantuaniju ob njegovem uradnem obisku z namenom, da zbirko popiše, je razkril vse prej kot urejeno stanje. Že takrat so določeni predmeti manjkali. Ne glede na to, da so grobne celote kontaminirane in je provenienca posameznih predmetov problematična, pa dokumentarna vrednost Goldbergovih zapiskov o grobovih in gomilah zagotovo ni sporna. Na osnovi njegovih precej podrobnih opisov, ki jih je v svoji objavi povzel Hencken, v čigar verodostojnost verjamemo, smo uspeli prepoznati lego malodane vseh takrat prekopanih gomil, razen prvih treh. Nekateri naši "ubikaciji" sicer oporekajo, vendar z ne prav prepričljivimi argumenti.²⁶

1.1.2 DOKUMENTACIJA O IZKOPAVANJIH

Najstarejši znani dokument, ki govori o izkopanih na Magdalenski gori, hrani dunajski muzej. Gre za pismo lokalnega zbiratelja starin Valentina Sadnikarja predsedniku Prazgodovinske komisije na Dunaju, Ferdinandu von Hochstetterju, v katerem piše o naključnem odkritju arheoloških predmetov v peskokopu na Laščiku pozimi 1881/82. O tej zadevi je mesec dni zatem poročal ravnatelj ljubljanskega muzeja Dragotin Dežman Deželnemu odboru, njegovo pismo je ohranjeno v Arhivu Republike Slovenije.²⁷

Terenske akcije Deželnega muzeja, ki so potekale v letih 1882–1884, so slabo dokumentirane. O kopanju muzejskega preparatorja Ferdinanda Schulza leta 1882 obstaja Dežmanovo poročilo Deželnemu zboru in odboru za Kranjsko, ki ga je dve leti zatem v celoti objavil v 14. številki *Mittheilungen der Anthropologischen Gesellschaft*. V njem piše o ogledu terena in Schulzovih odkritjih na Laščiku in Voselci. Poročilo je opremil z risbama fragmenta okrašene čelade in latenskih fibul iz gomile na Terišču ter z risbo kačaste fibule s pestiči in ptičkom na loku, ki je bila najdena v gomili 6 na Voselci, danes pa je pogrešana. Razen tega je dokumentiral tloris gomile 6 na Voselci in označil na njem pet skupkov najdb.²⁸ Izkopavanja v letu 1884 na Laščiku in ob poti

mother. In 1933, the collection travelled to Zürich, where it was arranged, listed and prepared for publication by top researchers of European prehistory. The publication, released in 1934, included a presentation of the cemetery at Magdalenska gora written by Raymond Lantier, then director of the Musée des Antiquités Nationales at Saint-Germain-en-Laye.²⁴

The auction of the Duchess' collection was held in January 1934 in New York, unsuccessfully. Due to a general economic crisis, the interested museums could not raise the means to purchase the collection in its entirety and, fortunately, it did not raise the interest of antiquarians. It was rather purchased in parts, by the British Ashmolean Museum in Oxford and the American Peabody Museum of Harvard University in Cambridge. The finds from Magdalenska gora, together with their documentation, ended up in the Peabody Museum due to considerable efforts by Hugh Hencken.

As discernible from the above, the collection had an eventful journey before reaching its permanent place at the Peabody Museum, which certainly influenced the reliability of the preserved contexts.²⁵ Even when still at Bogenšperk Castle, the Duchess kept the material from different sites together in three rooms. When Josip Mantuani, director of the museum in Ljubljana, came for an official visit to her castle in August 1919 with the aim of cataloguing the collection, he saw all but an orderly arrangement, with some of the finds missing. However, in spite of the fact that the grave groups are contaminated and the provenance of certain objects problematic, the documentary value of Goldberg's notes on graves and tumuli remains undisputed. Based on his quite precise descriptions, used by Hencken whose credibility is not to be questioned, we were able to identify the position of almost all of the tumuli excavated by the Duchess with the exception of the first three. It has to be said on that subject that there are some that contradict the proposed "ubiety"; their arguments, however, are not convincing.²⁶

1.1.2 DOCUMENTATION OF THE EXCAVATIONS

The oldest known document mentioning the finds from Magdalenska gora is kept at the Museum of Natural History in Vienna. It is a letter by Sadnikar to Ferdinand von Hochstetter, president of the Prehistoric Commission in Vienna, in which Sadnikar writes of a chance discovery of archaeological objects in a gravel

²⁶ Vuga 2006, 226 ss. V odgovoru na njegovo kritiko je Dular še bolj obširno in nazorno predstavil argumente za našo rekonstrukcijo: glej Dular J. 2007a, 435 ss.

²⁷ Pismo Sadnikarja Hochstetterju z dne 2. 2. 1882 (*Fundaktenarchiv Prähistorische Abteilung NHMW*); pismo Dežmana Deželnemu odboru z dne 6. 3. 1882 (*Archiv RS*, fond AS 38, Deželni zbor in odbor za Kranjsko IX-5, 1882/1459).

²⁸ Deschmann, Bericht über die vom krainischen Landesmuseum im Jahre 1882 vorgenommenen prähistorischen Ausgrabungen – 25. 3. 1883 (*Archiv RS*, fond AS 38, Deželni zbor in odbor za Kranjsko IX-5, 1883/2007); Deschmann 1884, 49 ss; glej še Tecco Hvala/Dular/Kocuvan 2004, sl. 15, 16, 42 in 43.

²⁴ Lantier 1934.

²⁵ Hencken 1978, 2; Weiss 1996; Gabrovec 2008, 19 ff; Dular J. 2009a; Božič 2009.

²⁶ Vuga 2006, 226 ff. Janez Dular responded to Vuga's critique with more extensive and persuasive argumentation in favour of our reconstruction: see Dular J. 2007a, 435 ff.

k cerkvi sv. Magdalene omenja Schulz v spisu, ki je v arhivu dunajskega muzeja.²⁹

Podatki o teh najzgodnejših odkritjih so skopi in sumarni, zato situacije ni bilo mogoče v celoti rekonstruirati. Na osnovi opisov in redkih skic se je dalo le v grobem ugotoviti lokacije, kjer so kopali, in delno sestaviti nekaj grobnih celot.³⁰

Pečnikovo delo na Magdalenski gori v letih 1892 in 1893 je razvidno iz njegovih pism Centralni komisiji in Deželnemu odboru, ki so ohranjena v Arhivu RS; v glavnem se nanašajo na kopanje gomile 2 na Prelogah ter na težave s pridobivanjem finančnih sredstev za delo.³¹ Na terenu sta ga bolj ali manj redno obiskovala Simon Rutar in Konrad Črnologar, ki ju je Centralna komisija zadolžila za nadzor in poročanje o kulturnih spomenikih na Kranjskem. V akcesijski knjigi Narodnega muzeja je vložil Rutarjev seznam najdb iz grobov na Laščiku (na območju gomil 1–3 in 9–10) in na Prelogah (iz gomil 5 in 8), ki jih je predal Deželnemu muzeju.³² Rutar je ob terenskih ogledih izdelal tudi dva načrta situacije gomil – prvega je objavil v *Izvestjih Muzejskega društva za Kranjsko* leta 1893, drugega je priobčil dve leti kasneje v *Mittheilungen der k.k. Central-Commission*. Načrta glede števila gomil in oznak nista skladna.³³ V svojih prispevkih je Rutar poročal o Pečnikovih akcijah v letih 1892 in 1893 na Laščiku in Prelogah ter opisal zgolj pomembnejše grobove.³⁴ V njegovi zapuščini je ohranjen še načrt grobišča na Laščiku pa tudi nekaj Pečnikovih popisov najdb iz grobov gomile 2 na Prelogah in gomile 2 na Voselci.³⁵ Črnologar, ki je Rutarja v odsotnosti nadomeščal, je leta 1892 objavil kratko notico, ohranjeni sta tudi dve njegovi pismi iz leta 1893, v katerih govori o kopanju gomile 2 na Prelogah.³⁶ Zdi se, da si Pečnik na terenu spočetka ni

pit at Laščik in the winter of 1881/82. A month later, the matter was reported by Deschmann, director of the Provincial Museum in Ljubljana, to the Provincial Council (*Landesausschuss für Krain*); this letter is kept at the Archives of the Republic of Slovenia.²⁷

The field campaigns conducted between 1882 and 1884 by the Provincial Museum are poorly documented. The excavation in 1882 was conducted by Ferdinand Schulz, museum technician, and written about by Deschmann in his report to the Provincial Diet and the Council for Carniola (*Landtag und Landesausschuss für Krain*). This report was published in its entirety two years later, in Volume 14 of *Mittheilungen der Anthropologischen Gesellschaft*. The article reports on the survey of the site area and of Schulz's discoveries at Laščik and Voselca. It contains several figures, namely a drawing of a fragment of a decorated helmet and La Tène fibulae from a tumulus at Terišče, as well as a drawing of a serpentine fibula with antennae and a bird on the bow, which had been found in Tumulus 6 at Voselca and is today missing. It also includes the plan of Tumulus 6 at Voselca with marked five sets of finds.²⁸ In 1884, excavations were performed at Laščik and along the path to the church and were mentioned by Schulz in his report, now in the archives of the museum in Vienna.²⁹

The data on these earliest discoveries is scarce and sketchy and the situation could thus not be fully reconstructed. Nevertheless, descriptions and rare sketches enable a rough determination of the locations of excavation and a partial reconstruction of some of the grave groups.³⁰

Another excavator at Magdalenska gora was Pečnik. His work in 1892 and 1893 can be traced through his letters to the Central Commission and to the Provincial Council, kept at the Archives of the Republic of Slovenia; these mainly refer to the excavation of Tumulus 2 at Preloge and to the insufficient funds for working.³¹

²⁹ Schulz F. 1884, *Prähistorische Nachgrabungen in Krain im Jahre 1884 (Fundaktenarchiv Prähistorische Abteilung NHMW)*.

³⁰ Gabrovec 1964–1965b; Tecco Hvala/Dular/Kocuvan 2004, 19 ss in 88 s.

³¹ Pisma Pečnika Centralni komisiji z dne 29. 12. 1892 in 12. 1., 13. 2., 20. 2., 25. 2., 14. 3., 31. 3., 9. 4., 29. 4., 10. 5., 18. 6., 25. 6., 16. 7., 5. 10., 22. 10., 8. 12. 1893 ter 20. 2. 1895 (*Arhiv RS*, fond AS 1100, C. kr. spomeniški urad, K 61/20,21,24,25,26,33,34,39,40, 41,42,43,45,49,50; K 59/191); pismo Pečnika Deželnemu odboru z dne 25. 3. in 20. 4. 1893 (*Arhiv RS*, fond AS 38, Deželni zbor in odbor za Kranjsko IX-5, 1893/3150, 1893/5019).

³² S. Rutar, Starine najdene pri Sv. Magdaleni, katere daruje podpisani v imenu centralne komisije deželnemu muzeju. – 11. 11. 1892 (*Akcesijska knjiga NMS*, št. 1892/187).

³³ Rutar 1893a, 1 ss; id. 1895, 39 ss; glej še Tecco Hvala/Dular/Kocuvan 2004, sl. 13, 14, 21 in 22.

³⁴ Rutar 1893, IMK 3, 1 ss, 35 s, 207 s, 252 s; id. 1894, 183 s; id. 1895, 39 ss.

³⁵ Zapuščina Simona Rutarja, *NUK*, Rokopisni oddelek, Ms 1426, fasc. IX/47-49, 51, 56, glej še Dular J. 2003, sl. 26.

³⁶ Črnologar 1892, 127; Pismi Črnologarja Centralni komisiji z dne 24. 2. in 22. 3. 1893 (*Arhiv RS*, fond AS 1100, C. kr. spomeniški urad, K 61/18,44).

²⁷ Sadnikar's letter to Hochstetter (*Fundaktenarchiv Prähistorische Abteilung, Naturhistorisches Museum Wien*); Deschmann's letter to Deželni odbor (*Arhiv Republike Slovenije*: fond AS 38, Deželni zbor in odbor za Kranjsko IX-5, 1882/1459).

²⁸ Deschmann, Bericht über die vom krainischen Landesmuseum im Jahre 1882 vorgenommenen prähistorischen Ausgrabungen. – 25. 3. 1883 (*Arhiv Republike Slovenije*: fond AS 38, Deželni zbor in odbor za Kranjsko IX-5, 1883/2007); Deschmann 1884, 49 ff; see also Tecco Hvala/Dular/Kocuvan 2004, Abb. 15, 16, 42, 43.

²⁹ Schulz F. 1884, *Prähistorische Nachgrabungen in Krain im Jahre 1884 (Fundaktenarchiv Prähistorische Abteilung, Naturhistorisches Museum Wien)*.

³⁰ Gabrovec 1964–1965b; Tecco Hvala/Dular/Kocuvan 2004, 125 ff and 170 f.

³¹ Pečnik's letters to the *Zentral-Kommission* (*Arhiv Republike Slovenije*: fond AS 1100, C. kr. spomeniški urad, K 61 K 59/191); Pečnik's letters to Deželni odbor (*Arhiv Republike*

delal beležk; članek o izkopaninah na Magdalenski gori v *Izvestjih Muzejskega društva za Kranjsko* je napisal bolj ali manj po spominu; v njem je med drugim objavil tudi fotografijo groba iz gomile 12 na Joštarjevem lazju.³⁷ V kratki notici, ki sta jo skupaj z Rutarjem priobčila leto kasneje, pa je omenjena zadnja pošiljka gradiva, ki je bila predana dunajskemu muzeju.³⁸

Pomembnejši vir informacij o Pečnikovem kopanju predstavlja rokopisna dokumentacija, ki jo hrani dunajski muzej. Aprila 1893 se je namreč začelo njegovo sodelovanje s kustosom tega muzeja Josefom Szombathyjem in je v skladu z njegovimi napotki poslej gradivo vedno opremil z oznakami in opisi grobov.³⁹ Szombathy je v prispevku za *Mittheilungen der Anthropologischen Gesellschaft* 24 (1894) objavil okrašeno pasno spono, ki je bila najdena pri kopanju gomile 2 na Prelogah v grobu 58, danes pa je izgubljena. Nekajkrat je teren tudi obiskal in si svoja opažanja zapisal v dnevnik. V njem je zabeležil odkritje prvih dvajsetih grobov iz gomile 13 na Prelogah ter skiciral lego predmetov v grobu 13/10. Sicer pa je skrb za najdbe in dokumentiranje prepustil preparatorju Franzu Brattini, medtem ko je Pečnik nadzoroval kopače. Brattina je vestno zapisoval podatke o legi in relativni globini grobov ter načinu pokopa. V opisih je navajal tudi orientacijo okostij in položaj pridatkov, skiciral je prerez gomile, tlorise grobov 13/97, 13/100, 13/101, 13/136, 13/146 ter žarni grob 13/173 v preseku. V njegovih terenskih zapiskih so tudi skice posebnih najdb iz grobov 13/95, 13/152, 13/163 ter prerez lesene podloge iz groba 13/24. V pismu je Szombathyju poslal risbo znamenitega groba 13/55 z edinstveno čelado in okrašeno situlo.⁴⁰ V Brattinovem dnevniku se mestoma pojavljajo naknadni pripisi, ki jih je v petdesetih letih prejšnjega stoletja dodal Karl Kromer ob pregledu gradiva, ki ga je nameraval objaviti.⁴¹

Celostnega vpogleda v originalno dokumentacijo, ki jo hrani Peabodyjev muzej o izkopavanjih vojvodinje Mecklenburške, nismo imeli. Hencken je Goldbergove

While excavating, he received more or less regular visits from Simon Rutar and Konrad Črnologar, entrusted by the Central Commission with the supervision of and reporting on the cultural monuments in Carniola. The accession register of the museum in Ljubljana includes Rutar's list of finds from the graves at Laščik (in the area of Tumuli 1–3 and 9–10) and at Preloge (Tumuli 5 and 8), which he delivered to the museum.³² During his field surveys, Rutar drew up two ground-plans of the tumuli, publishing the first one in *Izvestja Muzejskega društva za Kranjsko* in 1893 and the second one in *Mittheilungen der Central Commission* two years later, whereby the plans do not agree in the number of tumuli and their markings.³³ Rutar also reported on Pečnik's campaigns in 1892 and 1893 at Laščik and Preloge, giving a description of only the more important graves.³⁴ Among his documentation is also a ground-plan of the cemetery at Laščik and several lists by Pečnik of the finds from the graves of Tumulus 2 at Preloge and Tumulus 2 at Voselca.³⁵ Črnologar, who replaced Rutar during his absence, published a short notice in 1892 and wrote two letters in 1893, where he reported on the excavation of Tumulus 2 at Preloge.³⁶ As for Pečnik, it appears that he did not make notes of his activities at first; the article on the finds from Magdalenska gora in *Izvestja Muzejskega društva za Kranjsko* was written more or less by memory. In it, he published a photo of a grave from Tumulus 12 at Joštarjev laz among other things.³⁷ Finally, the short notice, published by Pečnik and Rutar a year later, mentions the last consignment of material delivered to the museum in Vienna.³⁸

A more important source of information on Pečnik's excavations is the manuscript documentation kept at the museum in Vienna. Pečnik's collaboration with Joseph Szombathy, curator at the museum, began in April 1893. After this date, Pečnik equipped all the excavated material with markings and descriptions of

³⁷ Pečnik 1893, 41 ss; glej še Tecco Hvala/Dular/Kocuvan 2004, sl. 19.

³⁸ Rutar/Pečnik 1894, 78.

³⁹ Pismo Szombathyja Pečniku z dne 24. 4. 1893 (*Arhiv RS*, fond AS 965, Pečnik Jernej, fasc. 1); pisma Pečnika Szombathyju z dne 29. 5., 7. 7., 20. 9., 2. 10, 7. 12. 1893 in 18. 1., 29. 1., 14. 3., 1. 5., 23. 9., 5. 10., 14. 10., 30. 10., 11. 11., 15. 11. 1894 ter 19. 2. 1905 (*Fundaktenarchiv Prähistorische Abteilung NHMW*); pismo Pečnika Centralni komisiji z dne 15. 2. 1905 (*Arhiv RS*, fond AS 1100, C. kr. spomeniški urad, K 61/53); Dular J. 2003, 58 ss.

⁴⁰ J. Szombathy, Tagebuch, Büchlein 33; F. Brattina, Tagebuch, Büchlein 34; pismo Brattine Szombathyju z dne 7. 10. 1894 (*Fundaktenarchiv Prähistorische Abteilung NHMW*); Szombathy 1894, 231, sl. 280; glej še preris pasne sponse po Szombathyjevi objavi: Tecco Hvala/Dular/Kocuvan 2004, T. 53: 1 in sl. 27–40.

⁴¹ Tecco Hvala/Dular/Kocuvan 2004, 53, op. 174.

Slovenije: fond AS 38, Deželni zbor in odbor za Kranjsko IX-5, 1893/3150, 1893/5019).

³² S. Rutar, Starine najdene pri Sv. Magdaleni, katere daruje podpisani v imenu centralne komisije deželnemu muzeju. – 11. 11. 1892 (*Narodni muzej Slovenije*: Akcesijska knjiga, št. 1892/187).

³³ Rutar 1893a, 1 ff; *id.* 1895, 39 ff; see also Tecco Hvala/Dular/Kocuvan 2004, Abb. 13, 14, 21, 22.

³⁴ Rutar 1893, IMK 3, 1 ff, 35 f, 207 f, 252 f; *id.* 1894, 183 f; *id.* 1895, 39 ff.

³⁵ Documents of Simon Rutar (*Narodna in univerzitetna knjižnica*: Rokopisna zbirka, Ms 1426, fasc. IX/47-49, 51, 56); see also Dular J. 2003, Abb. 26.

³⁶ Črnologar 1892, 127; Črnologar's letters to the *Zentral-Kommission* (*Arhiv Republike Slovenije*: fond AS 1100, C. kr. spomeniški urad, K 61/18,44).

³⁷ Pečnik 1893, 41 ff; see also Tecco Hvala/Dular/Kocuvan 2004, Abb. 19.

³⁸ Rutar/Pečnik 1894, 78.

terenske opise povzel v katalogu grobov, v uvodnem poglavju pa je zapisal, da se načrti o legi grobov v gomilah, če so sploh kdaj obstajali, niso ohranili. Izjemo predstavlja delni tloris gomile X, ki ga je tudi objavil. Opozoril je, da so notice o gomilah I do IV ter IX površne, da je pri opisu grobov iz gomile I uporabil podatke, zabeležene z Goldbergovo pisavo na lističih, ki so bili priloženi k najdbam. Omenja tudi, da obstajata o gomilah V, VI, VIII in X dve verziji Goldbergovih zapiskov – prvo predstavlja njegova mala beležnica s kratkimi opisi grobov, drugo pa obširnejše zabeleške, ki so bile iztrgane in vključene v kartotečni indeks grobov. Na kartotečnih listih, ki so nastali ob pripravi zbirke za dražbo, je zabeležena številka gomile in pripadajočega groba ter datum izkopa, pridane so tudi fotografije predmetov in originalni deli Goldbergovega obširnega poročila v rokopisu, prav tako pa tudi lističi z njegovo pisavo, ki so bili priloženi k zavozu z najdbami. Hencken je še opomnil, da obe Goldbergovi različici poročil nista vedno skladni, razen tega se vedno ne ujemata z obstoječim stanjem, nekateri predmeti, ki jih navaja, so pogrešani. Sicer pa ugotavlja, da se je Goldbergov način dokumentiranja iz leta v leto izboljševal, izkopavanja so nazadnje tudi fotografsko dokumentirali. Ker so fotografije obledele, jih je Hencken v svoji objavi nadomestil z risbami, ki so izdelane po prvotni fotografski predlogi.⁴²

Nekaj dopisov, ki osvetljujejo drobce iz spleta okoliščin, povezanih z odtujevanjem najdb iz Mecklenburške zbirke, je očitno tudi v Berlinu in v arhivu švedske državne uprave za dediščino.⁴³ Vsekakor je pri obravnavanju grobnih celot, ki jih hrani Peabodyjev muzej, potrebna določena mera previdnosti. Za preverjanje verodostojnosti obstoječega stanja lahko služijo Goldbergovi zapiski, ki predstavljajo primarni vir.

1.1.3 ANALIZE KOSTNIH OSTANKOV

Za spoznavanje populacijske slike prazgodovinskih skupnosti in vloge živali v njihovem grobnem kultu so osteološki ostanki nedvomno izjemnega pomena, zato si je vredno ogledati rezultate analiz in omembe tovrstnih najdb z Magdalenske gore. Videti je, da so se kosti na Magdalenski gori zaradi pretežno dolomitne osnove bolje ohranile kot npr. v Stični ali Novem mestu. Pred štiridesetimi leti sta kostne ostanke v Peabodyjevem muzeju študijsko obdelala in predstavila v skupni publikaciji Sándor Bökönyi in J. Lawrence Angel. Bökönyi je v svoji razpravi *Data on Iron Age horse of Central and Eastern Europe* priobčil rezultate analize konjskih kosti in zob, Angel pa antropološko študijo z naslovom

⁴² Hencken 1978; Peabody Museum of Archaeology and Ethnology, Mecklenburg Collection Archives, Akcesija 34-25 in 40-77 – glej Polizzotti Greis 2006, op. 21, 22, 25, 27, 29 in 34.

⁴³ Gabrovec 1978, 130 ss; Weiss 1996, Abb. 3; id. 1999; Polizzotti Greis 2006, op. 26 in 28; Gabrovec 2008, 19 ss.

graves in accordance with Szombathy's instructions.³⁹ In the article in *Mittheilungen der Anthropologischen Gesellschaft* 24 (1894), Szombathy published a decorated belt buckle found in Grave 58 of Tumulus 2 at Preloge, which is now lost. He also made several visits to the site and noted his observations in a diary. The latter includes a description of the discovery of the first twelve graves in Tumulus 13 and a sketch of the position of finds in Grave 13/10. As for the finds, he entrusted Franz Brattina, the museum technician, with their care together with the documentation, while Pečnik supervised the diggers. Brattina diligently noted the position and relative depth of the graves as well as the burial rite. His descriptions also contained the orientation of the skeletons and position of the grave goods, he made sketches of the tumulus cross-sections, plans of Graves 13/97, 13/100, 13/101, 13/136, 13/146 and a cross-section of the cremation Grave 13/173. His field notes further include sketches of special finds from Graves 13/95, 13/152, 13/163 and a cross-section of the wooden bier from Grave 13/24. In a letter, he sent to Szombathy a drawing of the famous Grave 13/55 with a unique helmet and a decorated situla.⁴⁰ Brattina's diary contains occasional subsequent notes written by Karl Kromer in the 1950s when examining the material that he intended to publish.⁴¹

The original documentation of the excavation by the Duchess of Mecklenburg is held at the Peabody Museum. Goldberg's field notes were summarized by Hencken in his catalogue of graves, writing in the introduction that the ground-plans of tumuli have not survived, if they had ever existed at all. The exception is a partial plan of Tumulus X, which Hencken also published. He further pointed out that the notes on Tumuli I to IV and IX were sketchy and that, in describing graves from Tumulus 1, he used the information written in Goldberg's handwriting on slips of paper enclosed with the finds. Hencken further mentioned the existence of two versions of Goldberg's notes on Tumuli V, VI, VIII and X – the first in a small notebook with brief descriptions of graves, while the second are lengthier notes cut up and incorporated into the card index of graves. The index cards that were made during the preparation of the collection to be sold at an auction record the number of the tumulus, the number of

³⁹ Szombathy's letter to Pečnik (*Arhiv Republike Slovenije*: fond AS 965, Pečnik Jernej, fasc. 1); Pečnik's letters to Szombathy (*Fundaktenarchiv Prähistorische Abteilung, Naturhistorisches Museum Wien*); Pečnik's letter to the *Zentral-Kommission* (*Arhiv Republike Slovenije*: fond AS 1100, C. kr. spomeniški urad, K 61/53); Dular J. 2003, 58 ff.

⁴⁰ J. Szombathy, Tagebuch, Büchlein 33; F. Brattina, Tagebuch, Büchlein 34; Brattina's letter to Szombathy (*Fundaktenarchiv Prähistorische Abteilung, Naturhistorisches Museum Wien*); Szombathy 1894, 231, Abb. 280; see also Tecco Hvala/Dular/Kocuvan 2004, Abb. 27–40 and T. 53: 1.

⁴¹ Tecco Hvala/Dular/Kocuvan 2004, 143, n. 173.

Human skeletal material from Slovenia. Osem škatel s kostnimi ostanki iz Mecklenburške zbirke je shranjenih v osteološkem depoju Narodnega muzeja Slovenije (šk. 566–573), ki še čakajo na obdelavo;⁴⁴ prav tako doslej še ni bilo objavljeno osteološko gradivo, ki ga hrani Naravoslovni muzej na Dunaju.

ZOOLOŠKI OSTANKI

Bökönyi je analiziral živalske ostanke iz osmih grobov, ki jih je izkopala vojvodinja Mecklenburška (sl. 3). Iz grobov IV/43 s Prelog in V/29 z Laščika so se ohranili deli konjskih skeletov in zobovja, v VII/31 in VII/38 pa posamezna kost, medtem ko so bili v grobovih V/5 ter X/14, X/18 in X/28 najdeni posamezni zobje, v glavnem molarji (M_2 in M_3). Spol in starost je uspel določiti v dveh primerih, preostali so opredeljeni kot deli odraslega konja. V grobu IV/43 je bil po njegovih ugotovitvah pokopan tri- do štiriletni konj skupaj z nekaj kostmi goveda, v grobu V/29 pa trije ali štirje osebk, med katerimi je lahko določil dva samca – eden naj bi bil precej ostarel, drugi pa naj bi bil dopolnil približno devet let. Pri obeh je vidna obraba zob (premolarjev), za katero je domneval, da bi lahko bila posledica uporabe žval. Pri starem konju je opazil tudi resnejše patološke deformacije na vretencih in ekstremitetah, kar je verjetno povzročalo motnjo v gibanju živali, morda celo šepavost. Ob tem omenja, da so za grobni ritual mnogokrat izbirali obnemogle in bolne živali.⁴⁵

Nikjer ni pojasnjeno, kaj se je zgodilo s konjskim skeletom, ki je bil najden v grobu 6–7–7a iz gomile V na Laščiku, o katerem obstaja fotografija, ki jo je objavil Hencken (sl. 4). Razen tega omenja Hencken v katalogu grobov še druge pokope konj, ki jih Bökönyi ni vključil v svojo študijo. Zaradi preskromne ohranjenosti ni upošteval živalskih ostankov iz groba IV/32 s Prelog, imenovanega tudi konjski grob II, toda v opombi piše, da po karakteristikah pripadajo konju iste skupine kot ostali primerki z Magdalenske gore. Konjske kosti iz groba IV/40, ki ga je Goldberg označil kot konjski grob III, so pogrešane; izgubljeni so tudi ostanke konja, ki so razmetani ležali tik nad grobom VII/39. O grobu IV/30, ki ga je Goldberg označil kot konjski grob I, pa Hencken piše, da ni ohranjenih nobenih referenc o živalskih kosteh.⁴⁶

Ob tem je Bökönyi določil še nekaj drugih živalskih kosti, kot npr. goveda (*Bos taurus L.*) iz groba IV/43 in srne (*Capreolus capreolus L.*) v grobovih VII/31 in VII/38 s Prelog. Hencken navaja, da je opredelil še metatarzalne kosti srne (*Capreolus capreolus L.*) iz groba V/2 z Laščika, ki jih je Goldberg pripisal otroku, nadalje fragmente kosti domačega prašiča (*Sus scrofa dom. L.*) v grobu

the grave and the date of excavation. Attached to these cards were photographs of the objects, the original parts of Goldberg's more complete notes as well as the slips of paper or labels also in Goldberg's handwriting that had belonged to the packing cases of objects. Hencken remarked that the two versions of Goldberg's notes were not completely consistent and not always correspond to the existent state in the museum. Hencken observed that Goldberg's documentation method improved as the excavations progressed and even included photographic documentation. These photos faded and were substituted in Hencken's publication by drawings based on the original photos.⁴²

The last source to be considered are several letters illuminating the circumstances connected to the alienation of finds from the Mecklenburg Collection, which apparently exist in Berlin and in the archives of the Swedish National Heritage Board.⁴³ In view of the above, any analysis based on the grave groups kept at the Peabody Museum requires a certain degree of caution, whereby the existent state may be verified against Goldberg's notes as the primary source.

1.1.3 ANALYSES OF BONE REMAINS

Osteological remains undoubtedly represent a very important source of information on prehistoric communities and the role of animals in their funerary cults. The same holds true of the material from Magdalenska gora, the publications and analyses results of which will be discussed below. It seems that bones have been preserved better at Magdalenska gora than, for example, at Stična or Novo mesto, due to the predominantly dolomite bedrock. The bone remains kept at the Peabody Museum were studied some forty years ago by Sándor Bökönyi and J. Lawrence Angel, who presented their results in a joint publication. Bökönyi, in his discussion entitled *Data on Iron Age Horses of Central and Eastern Europe*, published the results of the analysis of horse bones and teeth, while Angel published an anthropological study entitled *Human Skeletal Material from Slovenia*. Besides the remains kept at the Peabody Museum, there are also eight boxes with bone remains from the Mecklenburg excavations kept in the osteological collection of the National Museum of Slovenia (Boxes 566–573), which still await analysis.⁴⁴ Also unpublished is the osteological material kept at the Natural History Museum in Vienna.

⁴² Hencken 1978; Polizzotti Greis 2006, n. 21, 22, 25, 27, 29, 34.

⁴³ Gabrovec 1978, 130 ff; Weiss 1996, Abb. 3; *id.* 1999; Polizzotti Greis 2006, n. 26 and 28; Gabrovec 2008, 19 ff.

⁴⁴ Stare V. 1994, 72 ff.

⁴⁴ Stare V. 1994, 72 ss.

⁴⁵ Bökönyi 1968, 11 ss, Fig. 1–3.

⁴⁶ Hencken 1978, 22 s, 25, 30 s, 58, Fig. 108.

Gom./gr. Tum./Gr.	Inv. št. Inv. No.	Opis	Description
IV/43	7678	– ostanki skeleta in zob 3 ½ ali 4 ½-letnega konja – 9 astragalnih kosti in skočnici 7–8 let starega goveda (<i>Bos taurus L.</i>)	– fragments of skeleton and teeth of a 3 ½ to 4 ½-year-old horse – 9 fragments of astragali and 2 calcanei of 7–8-year-old cattle (<i>Bos taurus L.</i>)
V/5	7682	2 zoba (M_2 , M_3) odraslega konja	2 teeth (M_2 , M_3) of an adult horse
V/29	7679	– konj I: ostanki skeleta in zobovja starega samca; zelo močna obraba zob (P_1), okostenelost torakalnih in lum-balnih vretenc – konj II: ostanki skeleta in zobovja približno 9 let starega samca; močna obraba zob (P_1) – konj III: ostanki skeleta odraslega osebk – konj IV: ostanki tibije odraslega osebk	– horse I: fragments of skeleton and teeth of an old stallion with considerable tooth wear (P_1) and ossified thoracal and lumbar vertebrae – horse II: fragments of skeleton and teeth of an approximately 9-year-old stallion with considerable tooth wear (P_1) – horse III: fragments of adult horse skeleton – horse IV: fragments of adult horse tibia
VII/31	7684	– frag. astragalne kosti mladega konja – frag. lobanje odrasle srne (<i>Capreolus capreolus L.</i>)	– fragment of left astragalus of a young horse – skull fragment of an adult roe deer (<i>Capreolus capreolus L.</i>)
VII/38	7685	– frag. tibije mladega konja – frag. lobanje odrasle srne (<i>Capreolus capreolus L.</i>)	– fragment of young horse tibia – skull fragment of an adult roe deer (<i>Capreolus capreolus L.</i>)
X/14	7680	1 zob (M_2) odraslega konja	1 adult horse tooth (M_2)
X/18	7680	1 zob (P) odraslega konja	1 adult horse tooth (P)
X/28	7680	1 zob (M_3) odraslega konja	1 adult horse tooth (M_3)

Sl. 3: Prikaz osteoloških ostankov konj z Magdalenske gore (po Bökönyiju 1968).

Fig. 3: Overview of the osteological remains of horses from Magdalenska gora (after Bököny 1968).



Sl. 4: Konjski skelet iz groba V/6–7–7a (po Hencknu 1978, Fig. 108).

Fig. 4: Horse skeleton from Grave V/6–7–7a (after Hencken 1978, Fig. 108).

X/52 in vretence ovce (*Ovis aries L.*) ali koze (*Capra hircus L.*) iz groba VII/29 s Prelog, ki ga Goldberg sicer ne omenja. Po Hencknovih navedbah je nekaj živalskih ostankov določila tudi Barbara Lawrence, kustodinja za sesalce v muzeju za primerjalno zoologijo pri Harvardski univerzi; gre za krempelj medveda (*Ursus arctos*) iz groba V/11 z Laščika in volčji oz. bolj verjetno pasji zob v grobu VII/51 s Prelog, ki sta v funkciji obeskov.⁴⁷

⁴⁷ Ibid., 28, 32, 56, 61, 75.

ZOOLOGICAL REMAINS

Bökönyi analysed animal remains from eight graves excavated by the Duchess of Mecklenburg (fig. 3). Preserved from Graves IV/43 and V/29 are parts of horse skeletons and teeth, from Graves VII/31 and VII/38 single bones, while Graves V/5, 14, 18 and 28 in Tumulus X had been found to contain individual teeth, mostly molars (M_2 and M_3). The sex and age could be determined in two cases, while others were broadly determined as remains of adult horses. The first was a three- to four-year-old horse buried in Grave IV/43 together with several cattle bones, while Grave V/29 contained three or four horses, two of which were male – one old and the other adult, an approximately nine-year-old stallion. Both revealed considerable tooth wear (premolars), which Bökönyi assumed to be caused by the abrasive effect of the bridle. For the old horse he also noticed more serious pathological lesions on the vertebrae and extremities, which doubtlessly brought about locomotion disorders, possibly even lameness. In connection with this, Bökönyi mentioned the frequent use of weakened and diseased animals in funerary rituals.⁴⁵

The publication does not mention the horse's skeleton from Grave 6–7–7a of Tumulus V, a photo of which was published by Hencken (fig. 4). In the catalogue of graves Hencken mentions other burials of horses that Bökönyi did not include in his study. Neither did the latter study the animal remains from Grave IV/32, named also Horse Grave II, which was due to poor

⁴⁵ Bökönyi 1968, 11 ff, Figs. 1–3.

Bökönyijeva razprava pa ni omejena zgolj na analizo živalskih kosti iz Mecklenburške zbirke, temveč je širše zasnovana in usmerjena v primerjavo železnodobnih konjev na področju Srednje in Vzhodne Evrope. Na študijskem potovanju je imel možnost pregledati najdbe konj z bolj ali manj sočasnih najdišč v tem prostoru. Ob primerjanju analiz, ki so jih opravili njegovi predhodniki, pa tudi svojih (sam je desetletje pred tem analiziral konje z grobišča Szentes Vekerzug na Madžarskem), je ugotovil podobne karakteristike pri skitskih in grških konjih na ozemlju Ukrajine in južne Rusije, tračanskih konjih iz Bolgarije, iz grške kolonije *Histria* v Romuniji in skitskih konjih iz Madžarske ter z Dolenjske (Magdalenska gora, Stična in Brezje). V kasnejši študiji jim je pridružil še venetske konje.⁴⁸ Uvrstil jih je v prvo skupino konj, ki se po višji rasti, rahlo močnejših okončinah, predvsem pa po krajšem obraznem in nazalnem delu lobanje razlikujejo od halštatskih in latenskodobnih konj na območju Avstrije, Nemčije in Švice, ki so bili nižje rasti, imeli so vitkeje noge in daljši obrazni del. Na osnovi geografske razširjenosti obeh populacij konjev, ki sta prostorsko dokaj dobro ločeni, ju je označil kot vzhodno in zahodno skupino. Za izraz "skupina" se je odločil zaradi nevtralnosti in se tako namenoma izognil rabi terminov, kot sta "tip", ki naj bi predpostavljala genetsko različnost, ali "pasma", ki se nanaša na vzrejo konj z načrtno selekcijo, kar naj ne bi bilo dokazano. Ugotavljal je, da kaže vzorec zahodnih konj bolj homogeno sliko od vzhodnih, ki so heterogeni, kar je interpretiral kot morebitno posledico prilagajanja na dane pogoje v različnih naravnih okoljih.

Po spoznanjih, ki so prevladala v tistem času, je o vzreji domačih živali s selekcijo in o načrtnem križanju konj mogoče govoriti šele v rimskem obdobju v zvezi z rimsko konjenico. Ob tem pa Bökönyi ni izključil možnosti, da se je namenska vzreja konj v rudimentarni obliki začela razvijati že v železni dobi. Na to misel so ga privedla odkritja v kurganih iz Pazyryka, v katerih so bili pokopani konji, ki se razlikujejo po velikosti in konstituciji, kar je morda posledica boljše prehrane in skrbnejše reje. Med njimi izstopajo konji z maskami, ki so v višini vihra merili tudi 148 cm in so spadali med najboljše skitske konje. V zvezi s skitskimi konji navaja še eno zanimivo kulturno značilnost, ki jo predstavlja kratko pristrižena griva, kar kažejo upodobitve teh živali. Omenja tudi velik pomen konjev pri Keltih, kjer so morda veljali za neke vrste totemsko žival, kot sta jo nemara predstavljala tudi bik in prašič. Skratka, v njegovem diskurzu je moč najti zanimive nastavke za razumevanje vloge živali v različnih kulturnih okoljih.

Nekaj omemb živalskih kosti in zob najdemo tudi v opisih grobnih celot s Prelog, ki jih hrani Naravoslovni muzej na Dunaju. Odkritje konjskega okostja omenja Pečnik v grobovih 2/13 in 2/57, iz groba 2/88

preservation: he did add in a note that the animal's characteristics reveal a horse of the same group as the other examples from Magdalenska gora. Also missing are the horse bones from Grave IV/40, marked by Goldberg as Horse Grave III, as well as the remains of a horse that lay scattered just above Grave VII/39. As for Grave IV/30, marked by Goldberg as Horse Grave I, Hencken wrote that there are no preserved references of animal bones.⁴⁶

Besides horses, Bökönyi also determined bone remains of several other animals, namely of cattle (*Bos taurus L.*) in Grave IV/43 and roe deer (*Capreolus capreolus L.*) in Graves VII/31 and VII/38. Hencken stated that he also determined the metatarsal bones of a roe deer (*Capreolus capreolus L.*) in Grave V/2, which Goldberg ascribed to a child, as well as fragments of a domestic pig (*Sus scrofa dom. L.*) from Grave X/52, a vertebra of a sheep (*Ovis aries L.*) or a goat (*Capra hircus L.*) from Grave VII/29, not mentioned by Goldberg. According to Hencken, some animal remains were also determined by Barbara Lawrence, Curator of Mammals at the Museum of Comparative Zoology at Harvard University. She determined a claw of a brown bear (*Ursus arctos*) from Grave V/11 and a tooth of a wolf or more likely a dog from Grave VII/51, both serving as pendants.⁴⁷

Bökönyi's discussion is, as discernible from the title, not limited to analysing animal bone remains from Magdalenska gora, but is rather a comparative analysis of Iron Age horses in Central and Eastern Europe. During his study tour, he had the opportunity of inspecting horse finds from more or less contemporary sites in the above-stated regions. Comparing the analyses done by his predecessors as well as his own – a decade earlier he had analysed horses from the Szentes-Vekerzug cemetery in Hungary – he established similar characteristics between the Scythian and Greek horses on the territory of the Ukraine and southern Russia, Thracian horses from Bulgaria, the Greek colony of *Histria* in Romania, as well as the Scythian horses from Hungary and Dolenjska (Magdalenska gora, Stična and Brezje). In a later study, he added Venetic horses to the above.⁴⁸ All these horses were classified into the eastern group of larger-bodied and thicker-legged horses, with shorter facial and nasal skull parts, differing from the Hallstatt- and La Tène-period horses found in modern Austria, Germany and Switzerland, which were shorter, had slenderer legs and longer facial parts. Based on the different geographic distribution of both populations of horses, he marked them as the eastern and the western group. He chose the term "group" for its neutrality and thus intentionally avoided the use of terms such as "type", which would refer to genetic differences, or "breed", which refers to planned stock-breeding, neither of which could be proven. He observed that the sample of the western

⁴⁶ Hencken 1978, 22 f, 25, 30 f, 58, Fig. 108.

⁴⁷ *Ibid.*, 28, 32, 56, 61, 75.

⁴⁸ Bökönyi 1993, 11 ff, Abb. 14, 15.

⁴⁸ Bökönyi 1993, 11 ss, Abb. 14, 15.

pa konjske zobe; zobe navaja tudi v opisu groba 2/69, vendar jih ni prisodil nobeni konkretni živalski vrsti. V Brattinovich zapiskih zasledimo omembe konjskega skeleta in zobovja v grobu 13/119, pasjega podočnika v grobu 13/87 (menda je bil najden na prsnem košu pokojnice), fragmenta kozjega roga v grobu 13/132 in nesežgane kosti ovce ali kože v žarnem grobu 13/163.⁴⁹

ANTROPOLOŠKI OSTANKI

Predmet Angelove študije so bile človeške kosti. Tudi njegov vzorec je omejen na Mecklenburško zbirko. Kot piše, so bili skeleti na splošno slabo ohranjeni, kar je menda značilno za zmerni pas Evrope. Z magdalensko-gorskega najdišča je uspel opredeliti 28 oseb, med njimi 10 žensk in 18 moških. Na osnovi lobanj, od katerih je bila le ena v celoti ohranjena (inv. št. N/3683), je determiniral šest morfoloških tipov, ki jih je označil s črkami A do F (sl. 5 in 6). Primerjal jih je z mezolitskimi lobanjami z Bavarske, neolitskimi in eneolitskimi primerki z območja severovzhodnega Balkana ter halštatskimi iz Avstrije in latenskimi s Češke. Upošteval je tudi analize človeških ostankov iz železne dobe vse do rimskega časa z območja Glasinca v Bosni, iz Korinta, Atike, Beocije in grške Makedonije iz klasičnega obdobja, pa tudi analizo srednjeveških prebivalcev Ptuja iz 10. st. in Korošcev iz 17. do 19. st.

Tip A je opisal kot grobi mediteranski tip z robato in podolgovato lobanjo z nizkim in strmim čelom, s pravokotno oblikovanimi očesnimi votlinami in poudarjenimi nadočesnimi oboki. Zanj so značilne močne ličnice, kratek in raven nos, krepka brada in dobro razvito zobovje. Za nas je zanimivo, da je ta tip zastopan na grobišču v Novilari na zahodnojadranski obali.

Tip B je opredelil kot klasični mediteranski tip z majhno, gracilno podolgovato lobanjo z izbočenim in relativno nizkim ozkim čelom, s poudarjenim zatiljem in slabo izraženim mišičnim narastiščem. Obraz je ozek, s kvadratno oblikovanimi orbitami in stisnjenimi ličnicami, nos je majhen in ozek, spodnja čeljust s koničasto brado je rahlo potisnjena nazaj. Ta tip je bil menda razširjen v železni dobi na Apeninskem polotoku.

Tip C predstavlja t. i. alpski tip s srednje veliko in kratko, izbočeno lobanjo z ravnim zatiljem, širokim čelom, močnimi ličnicami in brado ter s konkavno profiliranim nosom. Angel piše, da je ta tip zelo blizu "sodobnim Korošcem".

Tip D označuje nordijsko-iranski tip s podolgovato glavo z izrazito nizkim zatiljem ter z visokim in širokim, nazaj pomaknjnim čelom. Obraz je podolgovat z rahlo povešenimi orbitami in udrtimi ličnicami. V profilu sta dominantna orlovski nos in močna čeljust z razcepljeno

⁴⁹ Tecco Hvala/Dular/Kocuvan 2004, 35, 44, 47, 66, 72, 73, 78. Za konjske pokope glej še Dular J. 2007b.

horses that he had studied was more homogenous in comparison to the heterogeneous eastern horses, which he interpreted as possibly the consequence of adapting to different environments.

According to the knowledge available at the time, breeding domestic animals through selection and planned crossbreeding of horses can only be spoken of in the Roman period in connection with the Roman cavalry. Having said that, Bökönyi did not exclude the possibility of intentional breeding of horses, in a rudimentary form, already beginning in the Iron Age. This consideration was brought on by the discoveries in the kurgans from Pazyryk that contained burials of horses differing in size and constitution, which might be the consequence of better fodder and more careful breeding. Exceptional among them are the masked horses, which measured up to 148 cm at the withers and ranked among the best Scythian horses. Bökönyi stated another interesting cultural characteristic in connection with the Scythian horses, namely manes cropped short, which can also be seen on the depictions of these animals. He mentioned the significance of horses for Celts, who possibly considered them a kind of totem animals, alongside other possible totem animals such as the bull and the pig. To conclude, his discussion offers interesting points of departure for understanding the role of animals in various cultural environments.

Finds of animal bones and teeth are also mentioned in the descriptions of grave groups kept at the Natural History Museum in Vienna. Pečnik mentions horse skeletons found in Graves 13 and 57 from Tumulus 2 at Preloge, while in Grave 2/88 he found horse teeth. Finds of teeth are also mentioned in the description of Grave 2/69, though Pečnik did not attribute them to any particular animal species. Brattina mentioned, in his notes on the excavation of Tumulus 13, parts of a horse skeleton and teeth in Grave 119, a canine tooth of a dog presumably found on the chest of a female buried in Grave 87, a fragment of a goat horn documented in Grave 132 from the same tumulus, while the cremation Grave 163 reportedly contained unburnt bones of a caprovid.⁴⁹

ANTHROPOLOGICAL REMAINS

The object of Angel's study was human bones, whereby his sample, as with Bökönyi, was limited to the Mecklenburg Collection. He wrote that the skeletons were in general poorly preserved, supposedly a characteristic of the temperate belt of Europe. He was able to determine 28 individuals, among them 10 female and 18 male. Based on the skulls, of which only one was completely preserved (inv. no. N/3683), he determined six morphological types marked with letters from A

⁴⁹ Tecco Hvala/Dular/Kocuvan 2004, 35, 44, 47, 66, 72, 78, 158. For the horse burials see also: Dular J. 2007b.



to F (figs. 5 and 6). These skulls were compared to the Mesolithic skulls from Bavaria, Neolithic and Eneolithic specimens from the north-eastern Balkans, Hallstatt skulls from Austria and La Tène skulls from the Czech Republic. He also took into consideration the analyses of human remains from the Glasinac area in Bosnia, spanning in date from the Iron Age to the Roman period, as well as remains from Corinth, Attica, Boeotia and Greek Macedonia from the Classical period, the analysis of the medieval inhabitants of the tenth-century Ptuj (Slovenia) and of Carinthians (Austria) from the seventeenth to the nineteenth centuries.

Type A was described as a coarse Mediterranean type with a rugged dolichocrane skull with a low and sloping forehead, angular orbits and heavy brow ridges. It had characteristic robust cheek bones, short and straight nose, strong chin and well-developed teeth. Of interest for this discussion is that this type can be found in the cemetery at Novilara on the west Adriatic coast.

Type B was described as the Classic Mediterranean type with a small, gracile dolichocrane and large-bossed skull with a relatively low and narrow forehead, prominent occiput and weak muscle markings. The face was narrow with square orbits and compressed cheek bones, the nose small and narrow, while the mouth region pinched and incipiently prognathous. In the Iron Age, this type was supposedly also spread on the Apennine Peninsula.

Type C represents the so-called Alpine type with medium-sized and short-headed vault, flat occiput, broad forehead, strong cheekbones and chin as well as a concave profile of the nose. According to Angel, the type is close to "recent" Carinthians.

Type D marks a Nordic-Iranian type with a long head, peculiarly deep occiput and a high and broad, receding forehead. The long face goes with slightly drooping orbits and retreating cheek bones, dominated in profile by a hawk-like nose and strong jaws with a cleft chin. The features of this type show virtual identity with rich Bavarian graves and close resemblances to Anglo-Saxon skulls, among others.

Type E, called Mixed Alpine, combines generalized Mediterranean with Alpine traits. The skull is notably mesocrane, had a long, broad and inflated frontal bone and weak cheek bones. The type is very similar to the Romano-Etruscan, on the one hand, and Scythian and some other types, on the other.

Sl. 5: Človeške lobanje z Magdalenske gore in njihova morfološka opredelitev po Angelu (1968, Fig. 1,4,6,9-11).

Fig. 5: Human skulls from Magdalenska gora and their morphological determination according to Angel (1968, Figs. 1,4,6,9-11).

1 – Tip / Type A (Preloge, Gr. IV/10); 2 – Tip / Type B (Preloge, Gr. X/26); 3 – Tip / Type C (neidentificiran grob HH / unidentified Grave HH); 4 – Tip / Type D (Preloge, Gr. X/28); 5 – Tip / Type E (Preloge, Gr. X/6); 6 – Tip / Type F (Preloge, Gr. X/37).

brado. Poteze tega tipa je moč zaslediti na lobanjah iz bavarskih bogatih grobov, kaže pa tudi veliko sorodnosti na primer z anglosaksonskimi lobanjami.

Type F is called Dinaric-Mediterranean and had a high face, marked by big and slightly drooping orbits and slightly flaring cheek bones. The height of the face was

Gom. / gr. Tum. / Gr.	Inv. št. / Inv. No.	Spol / Sex	Starost / Age	Morfološki tip Morphological type	Opis / Description
HH	3683	M	matur	C	4 zobe zgubil za življenja, 2 kariesa, 3 abscese; nezaceljena trepanacija / 4 teeth lost in life, 2 caries, 3 abscesses; unhealed trephination
FF	3678	F	matur	D	Poteze alpskega mešanega tipa; 5 zob izgubila za življenja, 5 kariesov / Traits of mixed Alpine type; 5 teeth lost in life and 5 caries
LL	3681	F	adult iuv.	E	
IV/II	3725	M	adult iuv.	C	181 cm visok; 1 karies / 181 cm tall; 1 caries
IV/3	3685	M	adult iuv.	E	Mešan alpski tip; 174 cm visok; podoben moškemu iz gr. X/12 / Mixed Alpine type; 174 cm tall; resemble the male from Gr. X/12
IV/10	3686	M	matur	A	Grob mediteranski tip; 6 zob izgubil za življenja, 1 karies, 1 absces / Rugged Mediterranean type; 6 teeth lost in life, 1 caries, 1 abscess
IV/14	3732	F	adult iuv.	C	
IV/25	3691	M	matur	C	Alpski tip; 165 cm visok / Alpine type; 165 cm tall
IV/30	3692	M	matur senil.	E	Z dobrimi zobmi / With good teeth
IV/54	3696	F	iuvenis	E	
IV/55a	3697	F	adult iuv.	E	Mešan alpski tip z izrazitimi mediteranskimi potezami / Mixed Alpines type with superficially Mediterranean traits
IV/55b	3697	M	adult iuv.	E	2 zoba izgubil za življenja / 2 teeth lost in life
IV/58	3699	M	adult iuv.	B	Gracilni mediteranski tip / Gracile Mediterranean type
V/24	3726	F	adult iuv.	A	
X/3	3702	F	adult iuv.	A	Podobna moškemu iz gr. IV/10 / Resembles the male from Gr. IV/10
X/6	3703	M	matur	E	Mešan alpski tip; podoben moškima iz gr. IV/30; 1 zob izgubil za življenja, 1 karies / Mixed Alpine type; resemble the males from Gr. IV/30; 1 tooth lost in life, 1 caries
X/7	3704	M	adult iuv.	C	Alpski tip z dinarskimi potezami; 174 cm visok; 3 kariese / Alpine type with Dinaric traits; 174 cm tall; 3 caries
X/12	3706	M	matur	E	Podoben moškemu iz gr. IV/3 / Resembles the male from Gr. IV/3
X/16	3708	F	adult iuv.	C	
X/18	3709	F	adult iuv.	C	Slabo zobovje / Poor teeth
X/20	3711	M	matur	D	Nordijsko-iranski tip z dobrim zobovjem; podoben moškima iz gr. X/25 in X/57 / Nordic-Iranian type with good teeth; resembles the males from Gr. X/25 and X/57
X/25	3712	M	adult iuv.	D	170,5 cm visok, z odličnim zobovjem; podoben moškima iz gr. X/20 in X/57; na levi orbiti zaceljena rana in sveža rana na temenu / 170.5 cm tall with excellent teeth; resembles the males from Gr. X/20 and X/57; old healed wound over the left orbit and new slash across the forehead
X/26	3713	F	adult iuv.	B	S šibkimi dinarsko-mediteranskimi tendencami; podobna moškemu iz gr. X/32 / With Dinaric-Mediterranean tendencies; resembles the male from Gr. X/32
X/28	3714	M	adult iuv.	D	Idealni halštatsko-nordijski tip, z dobrim zobovjem; 180 cm visok / Ideal Hallstatt Nordic type with good teeth; 180 cm tall
X/32-33	3716	M	Matur	B	3716 – z dinarsko-mediteranskimi tendencami; 4 molarje izgubil za življenja / with Dinaric-Mediterranean trend; 4 molars lost in life
	8548	?	?	?	8548 – medvretenčna hernija, deformacija vretenc in tibije / intervertebral disk herniation; tibial retroversion and vertebral osteophytes
X/37	3719	M	matur	F	Edini čisti primerek dinarsko-mediteranskega tipa; 2 kariesa, 2 abscesa, indikacija globoke infekcije <i>galea aponeurotica</i> / Only clear example of Dinaric-Mediterranean type; 2 caries and 2 abscesses, indication of an infection deep to the <i>galea aponeurotica</i>
X/57	3721	M	matur	D	Halštatsko-nordijska mešanica / with traits of a Hallstatt Nordic amalgam
X/64	3722	M	adult iuv.	C	Alpski tip; visok 181 cm; 5 kariesov / Alpine type; 181 cm tall; 5 caries

Sl. 6: Opredelitev človeških okostij z Magdalenske gore po Angelu (1968).
Fig. 6: Determination of human bones from Magdalenska gora after Angel (1968).

Tip E, imenovan mešani alpski tip, predstavlja kombinacijo splošno mediteranskih in alpskih potez z opazno podolgovato lobanjo in dominantnim izbočnim čelom ter šibko izraženimi ličnicami. Mešan alpski tip naj bi bil zelo podoben rimsko-etrusčanskemu na eni strani, po drugi pa je podoben skitskemu tipu in še nekaterim drugim.

Tip F je opredeljen kot dinarsko-mediteranski s podolgovatim obrazom in poudarjenimi velikimi in povešenimi orbitami in rahlo štrlečimi ličnicami. Podolgovatost obraza poudarja oblika čeljusti z gostimi zobmi. Ta tip se umešča med dinarizirane primerke mediteranske in balkansko alpske skupine.⁵⁰

Angel je ugotovil, da je bila železnodobna skupnost na Magdalenski gori heterogena. Med obravnavanimi predstavniki (*sl. 6*) jih večina kaže značilnosti t. i. alpskega tipa (59%), manj jih ima mediteranske poteze (20%); v manjšini je tudi nordijska skupina (17%), medtem ko so dinarske poteze komajda zaznavne (4%).⁵¹

Na osnovi generaliziranega vzorca je opisal povprečnega Magdalenskogorca kot dokaj visokega, precej krepke postave, toda ne prav mišičastega; glavo je imel jajčasto ovalne oblike, obraz podolgovat s širokim topim čelom ter dolgim krepkim nosom z bolj ali manj ravnim profilom; zobe je imel dokaj zdrave, imel je močno čeljust z rahlo izbočeno mandibulo (*prognatizem*).

Pri nekaterih morfološko različnih lobanjah je opazil skupne značilnosti. Kot pravi, gre morda za družinske poteze (npr. med lobanjami *N/3711*, *N/3719* iz gomile X in *N/3697* iz gomile IV ali pa med primerki *N/3712* iz gomile X in *N/3699* iz gomile IV na Prelogah ter *N/3683*). Dve kombinaciji potez sta po njegovi oceni fenotipski dokaz za rekombinacijo in domnevno križanje sorodstvenih skupin: prvo predstavlja izbočeno, na sencih rahlo stisnjeno čelo, ki v nekaterih primerih prehaja v visoko izbočen nos, kar je vidno pri osmih lobanjah iz različnih gomil (*N/3711*, *3714*, *3721*, *3719*, *3725*, *3708*, *3732* in pri lobanji z Bogenšperka *N/3744*); drugo kombinacijo predstavlja konveksno izbočen predel okoli ust (*prognatizem*) z rahlo štrlečimi zobmi ter nazaj pomaknjeno čeljustjo z relativno kratkim *ramusom*, kar je še posebej opazno v alpski skupini (*N/3713*, *3719*, *3691*, *3704*, *3703*, *3683*, *3711*, *3714* in *3716* po vrstnem redu upadanja izrazitosti). Te posebnosti skupaj z nenavadno visokimi nadočesnimi oboki pripisuje verjetni rekombinaciji specifičnih lokalnih potez, ki kaže na nekakšno izoliranost magdalensko-gorske skupnosti, kjer je do večjega mešanja prišlo kake tri generacije prej.

Kljub majhnosti vzorca je izračunal tudi povprečno starost ob smrti: moški naj bi v povprečju umirali pri 40,7 letih, ženske pri 31,3 letih. To starostno razliko med spoloma je pogojno pripisal umrljivosti žensk

emphasized by the shape of the jaw with crowded teeth. This type stands between the "dinaricised" Mediterranean series and the dinaricised Balkan-Alpine groups.⁵⁰

Angel established that the Iron Age community at Magdalenska gora was heterogeneous. Most of the individuals analysed (*fig. 6*) show traits of the so-called Alpine type (59%). Individuals with Mediterranean feature are in a minority (20%); the same holds true of the Nordic group (17%), while the Dinaric traits are hardly present (4%).⁵¹

Generalizing from his sample, Angel described the average inhabitant of Magdalenska gora as a fairly tall, robustly built individual without excessive muscular crests, with an ovoid-ellipsoid head, large face with a broad and blunt forehead and a long and thick nose of a more or less straight profile. The teeth were of good quality and few were lost in life. The jaw was large and heavy with small-medium protrusion (*prognathism*).

He observed common characteristics on some morphologically different skulls, which he interpreted as family traits (for example on skulls *N/3711*, *N/3719* and *N/3697*; or between skulls *N/3712*, *N/3699* and *N/3683* from Tumuli IV and X). He estimated that two sets of trait combinations represent a phenotypical proof of recombinations and presumably crossing over of linkage groups. The first such combination is the arched, slightly pinched and incipiently byrsoid frontal bone, sometimes going with a high-arched nose, a combination seen in eight skulls from different tumuli (*N/3711*, *3714*, *3721*, *3719*, *3725*, *3708*, *3732* and the skull from Bogenšperk *N/3744*). The second is the combination of a convex or slightly prognathous mouth region with a sloping teeth row and a jaw with somewhat receding chin with a relatively short *ramus*, which is especially noticeable in the Alpine group (*N/3713*, *3719*, *3691*, *3704*, *3703*, *3683*, *3711*, *3714* and *3716* in descending order of definiteness). Angel attributed these particularities, as well as the occurrence of unexpectedly high orbits, to special local trait recombinations, which makes the Magdalenska gora series appear as a relatively isolated group where the last extensive mixture took place three generations or so earlier.

In spite of the small sample, Angel calculated the average age at death: men supposedly died at 40.7 and women at 31.3 years of age. This big age difference between the sexes was conditionally ascribed to the mortality of women at childbirth and possibly to hard work. The cause of death is unknown in most cases, with two exceptions. The skull of the first, late middle-aged, individual (*N/3683*) from the destroyed Grave HH showed traces of *trephination*, which Angel determined as possibly the final and fatal attempt at relieving symptoms of a chronic infection that might have begun in the middle

⁵⁰ Angel 1968, 75 ss.

⁵¹ *Ibid.*, 101.

⁵⁰ Angel 1968, 75 ff.

⁵¹ *Ibid.*, 101.

pri porodih in morda težkemu delu. V glavnem se za vzroke smrti ne ve, le v dveh primerih jih je moč slutiti. Na lobanji moškega poznih srednjih let (*N/3683*) iz uničenega groba HH so opazne sledi *trepanacije*, ki jo je Angel označil kot zadnji in morda usodni poskus lajšanja simptomov kronične infekcije, ki se je začela v srednjem ušesu.⁵² Pri mlajšem moškem (*N/3712*) pa je vidna zaceljena rana na spoju leve ličnice s čelnico ter druga nezaceljena poškodba sredi čelne kosti, ki je po njegovem mnenju verjetno nastala zaradi smrtonosnega udarca z ostrim rezilom.

Čeprav se rezultati Angelove antropološke analize nanašajo le na neznamen delež magdalenskogorske populacije, jih pri obravnavi družbene strukture ne gre prezreti. Zanimivi utegnejo biti v povezavi z nošo pokojnikov in drugimi pridatki v grobu, pa tudi v zvezi z mestom pokopa v okviru gomile oz. grobišča. Za primer si oglejmo predstavnike Angelovega morfološkega tipa A, opisanega kot grobi mediteranski tip, ki je znan tudi iz picenskega najdišča v Novilari. Podobne poteze je zasledil pri zrelem moškem iz groba IV/10 s Prelog in pri dveh mladenkah iz grobov V/24 z Laščika in X/3 s Prelog; pokopani so bili torej v različnih gomilah, skupno pa jim je to, da niso imeli nikakršnih pridatkov. Drug primer predstavlja morfološki tip E z mešanimi alpskimi potezami, ki je najštevilneje zastopan v gomili IV na Prelogah. Večinoma gre za moške,⁵³ mladi ženski je Angel prepoznal v grobovih IV/54 in IV/55a, vendar sta ta dva konteksta vprašljiva. V grobu IV/54 je bila najdena sulična ost, v grobu IV/55 pa naj bi po Goldbergovem opisu našli en skelet, medtem ko je Angel prepoznal moškega in žensko, ki je imela izrazito mediteranske poteze. Hencken piše, da je bil del lobanje iz groba IV/10 med predmeti groba IV/55, del lobanje iz groba IV/55 pa je bil menda poslan Peabodyjev muzej v sklopu groba IV/11, kar kaže na zamešanost teh grobnih celot. Nekateri pripadniki tipa E iz gomile IV so očitno dosegli visok položaj v družbi – mladec iz groba IV/3 je imel čelado, starec iz groba IV/30 pa konjsko opremo. Slednjemu naj bi bil podoben možak zrelih let, ki je bil pokopan brez pridatkov v drugi gomili na Prelogah (X/6). Moškemu, ki je nosil sestavljeno čelado (IV/3), pa naj bi bil podoben pokojnik iz groba X/12, ki je bil skromno opremljen z eno sulico in eno plavutasto sekiro. S plavutasto sekiro sta bila oborožena npr. mladenič z gracilnimi mediteranskimi potezami (tip B) iz groba IV/58 ter predstavnik morfološkega tipa C iz groba X/64.⁵⁴

Opisani primeri ponazarjajo zapletenost te problematike. Iz razpredelnice (sl. 6) lahko razberemo, da so znotraj ene gomile zastopani različni morfološki tipi, kar bi kazalo v smer eksogamije. Angel je po nekaterih

ear.⁵² The second, male individual (*N/3712*) showed a healed wound depression pitting deeply just above the left fronto-malar suture and a crescentic slash through the mid-frontal zone, which, in his opinion, probably occurred due to a death-blow with a sharp object.

As seen above, the results of Angel's anthropological analysis are based on an almost negligible portion of the Magdalenska gora population. Nevertheless, they should not be overlooked when discussing the social structure at the site. Their importance lies in the connection with the costume of the deceased and other goods found in graves, as well as with the position of the burial within a tumulus or a cemetery. To illustrate, the individuals of Angel's morphological Type A, described as the rugged Mediterranean type known also from the Piceni site at Novilara, will be looked at more closely below. Angel observed common traits in a mature male from Grave IV/10 and in two young females from Graves V/24 and X/3; they were buried in different tumuli and none had any grave goods. The second example is the morphological Type E with Mixed Alpine traits, most numerous represented in Tumulus IV. Most of the individuals of this type are males.⁵³ Angel also identified two young females, in Graves IV/54 and IV/55a. However, the two contexts are questionable; Grave IV/54 contained a spearhead and Grave IV/55, according to Goldberg's description, contained a single skeleton, while Angel identified a male and a female, the latter with obvious Mediterranean traits. In connection with that Hencken wrote that part of the skull from Grave IV/10, which contained a skeleton and no grave goods, was found among the objects from Grave IV/55. Part of the skull from Grave IV/55, on the other hand, was supposedly sent to the Peabody Museum as part of the contents of Grave IV/11. Some individuals of Type E from Tumulus IV apparently achieved high social standing. For example, the young man from Grave IV/3 had a helmet, while the old man from Grave IV/30 was buried with horse gear. Similar to the latter was a mature man buried without grave goods in another tumulus (Grave X/6). The man with a composite helmet (Grave IV/3) was similar to the deceased from Grave X/12, modestly equipped with a spear and an axe, the latter between the socketed and the flanged type in shape. A flanged axe was the weapon of a young man from Grave IV/58 with gracile Mediterranean traits (Type B), as well as of a representative of the morphological Type C from Grave X/64.⁵⁴

The examples described above reveal all the complexity of the problem at hand. The table below (fig. 6) shows that different morphological types are present within a tumulus, which would point to exogamy. Certain common traits led Angel to the assumption that a

⁵² O *trepanaciji* v železni dobi v Srednji Evropi glej Pauli 1975, 166 ss.

⁵³ *Preloge, gr. IV/3, IV/30, IV/55b, X/6, X/12.*

⁵⁴ Hencken 1978.

⁵² On *trephination* in the Iron Age in Central Europe see Pauli 1975, 166 ff.

⁵³ *Preloge, Graves IV/3, IV/30, IV/55b, X/6, X/12.*

⁵⁴ Hencken 1978.

Gom./gr. Tum./Gr.	Opis	Description
II/22	otroški grob	Child's grave
IV/20	otroško okostje	Child's skeleton
V/2	Goldberg poroča o otroških kosteh najdenih pri nogah okostja odrasle osebe, ki jih je Bököny opredelil za kosti srne	Goldberg reports on child's bones found at the feet of an adult, determined as roe deer bones by Bököny
V/13-14	2 okostji, drugo ob drugem, domnevno naj bi šlo za možkega in žensko	2 skeletons one beside the other, supposedly a male and a female
V/19-20	2 slabo ohranjeni okostji	2 poorly preserved skeletons
V/29	človeške kosti 2 oseb in kosti 4 konjev	Human bones of 2 individuals and bones of 4 horses
V/44-45	2 okostji	2 skeletons
VI/33a	otroški grob	Child's grave
VII/40	grob zelo bogate ženske in morda tudi majhnega otroka (otroške kosti niso bile najdene)	Grave of a very rich woman and possibly a small child (child's bones were not found)
VIII/3	verjetno gre za grob ženske z otrokom; kosti so skoraj v celoti propadle	Probably the grave of woman buried with child; bones were almost completely decayed
VIII/10-11	2 zelo slabo ohranjeni okostji, drugo vrh drugega	2 poorly preserved skeletons, one above the other
VIII/17-18	2 okostji, drugo poleg drugega	2 skeletons, one beside the other
X/22	sledi okostja, ob njem pokopan tudi otrok	Traces of a skeleton with a child's burial beside it
X/24	sledi otroškega okostja	Traces of a child's skeleton
X/32-33	2 okostji, drugo ob drugem	2 skeletons, one beside the other
X/34-35	2 okostji, drugo vrh drugega; po Howellsu naj bi šlo za dve ženski	2 skeletons, one above the other, supposedly two females after Howells
X/67	otroški grob; ohranjene le sledi okostja.	Child's grave; only traces of bones preserved

Sl. 7: Goldbergove zabeležke o otroških in dvojnih pokopih z izkopavanj na Magdalenski gori (po Hencknu 1978).
Fig. 7: Goldberg's remarks on children's graves and multiple burials from excavations at Magdalenska gora (after Hencken 1978).

skupnih potezah domneval, da je do večjega mešanja prebivalstva na Magdalenski gori prišlo kake tri generacije prej, po njegovem povprečnem izračunu neke v času kulture žarnih grobišč.⁵⁵ Toda grobni pridatki pričajo, da je večina predstavnikov iz te vzorčne skupine živela v času negovske stopnje.⁵⁶ Tako bi lahko sklepali, da se je intenzivno mešanje dogajalo v času stopnje Stična, seveda ob predpostavki, da bi bila Angelova hipoteza o treh generacijah potrjena. Tako pa gre le za (pre)drzne ideje. Da na obstoječih podatkih ne moremo povsem nekritično graditi zaključkov, opozarjajo primeri nejasnih kontekstov, ki jih niti ni tako malo. Kar nekaj uničenih grobov z oznakami FF, HH, LL in IV/II pri Angelu ne moremo povezati s Hencknovim seznamom grobov, v nekaterih primerih pa so očitna razhajanja med Goldbergovim opisom grobnih pridatkov in Angelovo določitvijo spola ali števila okostij.⁵⁷

Povsem drugačne vrste vir predstavljajo opažanja izkopavalcev. Čeprav ne gre za strokovnjake za določanje kosti, so njihovi opisi pomenljivi, zlasti ko gre za omembe otrok in dvojnih pokopov ter izmerjeno

more substantial mixing of population occurred roughly three generations earlier, according to his mean calculation sometime during the Urnfield period.⁵⁵ However, grave goods set the lives of most of the representatives of this sample group into the time of the Negova phase.⁵⁶ On the basis of the latter, we might infer that a more extensive mixing of the different morphological types occurred during the Stična phase, if, of course, Angel's hypothesis were confirmed. As it is, these are only (too) bold ideas. The existing data forms an unreliable basis for drawing conclusions, which is revealed by the examples of unclear contexts that are not so few in number. There are, on the one hand, several destroyed graves marked FF, HH, LL and IV/II in Angel's discussion, which cannot be related to Hencken's list of graves, and, on the other hand, there are differences between Goldberg's descriptions of grave goods and Angel's determination of sex or number of skeletons.⁵⁷

Quite a different kind of a source is the observations of the excavators. Though no experts in osteology, their descriptions are nevertheless telling, particularly when

⁵⁵ Angel 1968, 98.

⁵⁶ *Preloge, gr. IV/30, IV/58, X/12, X/18, X/20, X/25, X/32, X/64.*

⁵⁷ Gre za gr. IV/54, IV/55, X/18 in X/37.

⁵⁵ Angel 1968, 98.

⁵⁶ *Preloge, Gr. IV/30, IV/58, X/12, X/18, X/20, X/25, X/32, X/64.*

⁵⁷ See Gr. IV/54, IV/55, X/18, X/37.

Gom./gr. Tum./Gr.	Opis	Description
1892/8	Žensko okostje: Našli ... tri cele mrliče, med njimi veliko žensko ... (po Rutarju)	Female skeleton: one big woman was found among three corpses (after Rutar)
1893/1	Otroško okostje (po Pečniku)	Child's skeleton (after Pečnik)
2/a	Žensko okostje: Nenavadno velik ženski skelet (po Črnologarju); nenavadno velika in bogata ženska, kakršna še ni bila najdena na Kranjskem (po Rutarju)	Female skeleton: an unusually big female skeleton (after Črnologar); an unusually big and rich woman such as has not yet been found in Carniola (after Rutar)
2/c	8-10 letna deklica (po Pečniku)	8-10 year-old girl
2/o	Otroško okostje (po Pečniku)	Child's skeleton (after Pečnik)
2/11	Otroško okostje (po Pečniku)	Child's skeleton (after Pečnik)
2/37	Otroško okostje (po Pečniku)	Child's skeleton (after Pečnik)
2/48	14-16 letna deklica (po Pečniku) oz. 15-16 letna deklica (po Rutarju)	14-16 year-old girl (after Pečnik) or 15-16 year-old girl (after Rutar)
2/55	Otroško okostje (po Pečniku)	Child's skeleton (after Pečnik)
2/65	Otroški grob brez okostja (po Pečniku)	Child's grave without bones (after Pečnik)
2/66	Otroško okostje (po Pečniku)	Child's skeleton (after Pečnik)
2/81	Otroško okostje (po Pečniku)	Child's skeleton (after Pečnik)
13/3	Okostje dolžine 172-175 cm (po Szombathyju)	Skeleton, length 172-175 cm (after Szombathy)
13/7	Lobanja mlade osebe (po Szombathyju)	Skull of a young individual (after Szombathy)
13/9	Lobanja velike osebe (po Szombathyju)	Skull of a big individual (after Szombathy)
13/11	Lobanja mlade osebe (po Szombathyju)	Skull of a young individual (after Szombathy)
13/13	Otroška lobanja (po Szombathyju)	Child's skull (after Szombathy)
13/21	Okostje dolžine 170 cm (po Brattini)	Skeleton, length 170 cm (after Brattina)
13/37	Okostje dolžine 170 cm (po Brattini)	Skeleton, length 170 cm (after Brattina)
13/37a	Otroška lobanja (po Brattini)	Child's skull (after Brattina)
13/40	Okostje dolžine 160 cm (po Brattini)	Skeleton, length 160 cm (after Brattina)
13/46	Otroško okostje? (po Brattini)	Child's skeleton? (after Brattina)
13/60	Okostje dolžine 175 cm (po Brattini)	Skeleton, length 175 cm (after Brattina)
13/61	Otroško okostje (po Brattini)	Child's skeleton (after Brattina)
13/66	Otroško okostje (po Brattini)	Child's skeleton (after Brattina)
13/69	Okostje dolžine 170 cm (po Brattini)	Skeleton, length 170 cm (after Brattina)
13/71	Okostje dolžine 175 cm (po Brattini)	Skeleton, length 175 cm (after Brattina)
13/77	a) žensko okostje dolžine 160 cm b) otrok ležal ob njej na desni strani (po Brattini)	a) Female skeleton, length 160 cm b) Child lay to her right (after Brattina)
13/81	Okostje dolžine 170 cm (po Brattini)	Skeleton, length 170 cm (after Brattina)
13/84	Okostje dolžine 170 cm (po Brattini)	Skeleton, length 170 cm (after Brattina)
13/85	Okostje dolžine 170 cm (?), kosti niso bile v pravilni legi (po Brattini)	Skeleton, length 170 cm (?), the bones were in irregularly position (after Brattina)
13/90	Okostje dolžine 180 cm (po Brattini)	Skeleton, length 180 cm (after Brattina)
13/109	Okostje dolžine 170 cm (po Brattini)	Skeleton, length 170 cm (after Brattina)
13/114	a) odrasla oseba b) otroška lobanja (po Brattini)	a) Adult individual b) Child's skull (after Brattina)
13/115	Okostje dolžine 180 cm (po Brattini)	Skeleton, length 180 cm (after Brattina)
13/116	Skelet ene osebe in še 2 tibiji ter sledi kosti druge osebe (po Brattini)	Skeleton of one individual as well as another 2 tibiae and traces of the bones of another individual (after Brattina)
13/117	Okostje dolžine 185 cm (po Brattini)	Skeleton, length 185 cm (after Brattina)
13/119	Okostje dolžine 175 cm (po Brattini)	Skeleton, length 175 cm (after Brattina)
13/136	Okostje dolžine 180 cm (po Brattini)	Skeleton, length 180 cm (after Brattina)
13/140	Otroška lobanja, starost ob menjavi mlečnih zob (po Brattini)	Child's skull of the age of milk teeth alternation (after Brattina)
13/149	Otroško okostje (po Brattini)	Child's skeleton (after Brattina)
13/150	Okostje dolžine 160 cm (po Brattini)	Skeleton, length 160 cm (after Brattina)
13/151	Otroško okostje? - majhna lobanja in kratke kosti (po Brattini)	Child's skeleton? - small skull and short bones (after Brattina)
13/152	Okostje dolžine 170 cm (po Brattini)	Skeleton, length 170 cm (after Brattina)
13/164	Okostje dolžine 180 cm (po Brattini)	Skeleton, length 180 cm (after Brattina)
13/172	Mlada oseba (po Brattini)	Young individual (after Brattina)

Sl. 8: Zabeleške o človeških okostjih s Pečnikovih izkopavanj na Magdalenski gori.
Fig. 8: Remarks on human bones from Pečnik's excavations at Magdalenska gora.

dolžino skeletov ob samem odkritju. Goldbergovi terenski zapiski so bili v prvih letih izkopavanj bolj površni, v kasnejših beležkah (od gomile V naprej) pa je natančneje opisoval položaj groba v gomili, velikost grobne jame (kadar je bila prepoznavna), ohranjenost in orientacijo okostja ter položaj predmetov v grobu. Na razpredelnici (*sl.* 7) so navedene njegove omembe otroških in dvojnih pokopov, kakor jih je povzel Hencken v katalogu grobov.

Prav tako so dragocena Pečnikova opažanja in Brattinove zabeležke o velikosti okostij. Brattina, ki je bil zadolžen za dokumentiranje najdb ob izkopavanju gomile 13 na Prelogah, je mnogokrat izmeril dolžino okostja (*sl.* 8). Mere, ki jih zasledimo v njegovem terenskem dnevniku, pritrjujejo ugotovitvam Angela, da so bili magdalenskogorski prebivalci precej visoke rasti. Prav presenetljiva je višina pokojnic iz grobov 2/a, 13/90 in 13/117 s Prelog, ki so merile 180 cm in več. Da gre zelo verjetno za osebe ženskega spola, kaže predvsem nakit, ki je bil v grobovih 2/a in 13/117 za povrh še izjemno bogat; imeli sta celo zlate lističe in vrhunske izdelke situlske umetnosti.⁵⁸ Seveda pa danes antropološka veda z razvojem genetike ponuja boljše možnosti za analizo demografske slike prazgodovinskih skupnosti.⁵⁹

1.2 METODOLOŠKI PRISTOP

Arheološke ostaline so edini razpoložljivi vir informacij za preučevanje strukture in razvoja prazgodovinskih družb. Po povednosti izstopajo grobišča, ki predstavljajo posebno mesto, kjer so "registrirani" preminuli člani neke skupnosti in kamor so "vpisani" v skladu z določenimi pravili in v določenem redu. V njih so zakodirani stvarni sorodstveni odnosi in povezave med generacijami, na simbolni ravni pa tudi idejna in družbena kohezija ter vrednotenje statusa posameznega člana v življenju teh skupnosti. Pogrebni ceremoniali in grobni rituali so sestavljeni iz cele vrste pravil in ravnanj, prek katerih se obnavljajo družbene vezi, vzpostavljajo in prenašajo kulturni vzorci ter ohranjajo in izkazujejo družbeni spomin, religiozne predstave ter z njimi povezano morebitno žrtvovanje, čaščenje prednikov, herojev ipd.⁶⁰ Od prazgodovinskega obredja se je ohranilo le malo sledi v obliki materialnih ostankov, ki se nanašajo v glavnem na:

⁵⁸ Tecco Hvala/Dular/Kocuvan 2004, 28 s, 66, 71, T. 7, 8, 96C, 105, 106.

⁵⁹ *Beiträge zur Archäozoologie und Prähistorischen Anthropologie* 1994; Hunter/Cox 2005.

⁶⁰ Humphreys/King (ur.) 1981; Gnoli/Vernant 1982; Hodder (ur.) 1982; Renfrew (ur.) 1984; Metcalf/Huntington 1985; Haffner 1989; Hodder (ur.) 1991; Clark (ur.) 1993; Davies 1997; Jensen/Nielsen (ur.) 1997; Chesson 2001.

mentioning children, multiple burials or the measured lengths of skeletons during excavation. Goldberg's field notes, for example, are not very precise in the first years of excavation. Later (from Tumulus V onwards), however, they include rather precise descriptions of the position of graves within tumuli, size of grave whenever discernible, preservation and orientation of skeletons as well as the position of grave goods. The table below (*fig.* 7) lists his references of child or double burials, as published by Hencken in his catalogue of graves.

Also valuable are Pečnik's observations on the size of the skeletons. Brattina, who was in charge of documenting finds during the excavation of Tumulus 13, measured the lengths of skeletons in numerous graves (*fig.* 8). These measurements, written in his field diary, confirm Angel's findings on the inhabitants being rather tall. The females buried in Graves 2/a, 13/90 and 13/117, for example, were quite stunningly tall, measuring 180 cm and more. The sex of these individuals is indicated mostly by their jewellery, in Graves 2/a and 13/117 even very rich with both graves containing gold leaves and high-quality products of the situla art.⁵⁸ With the development of genetics, however, the modern anthropological science offers new possibilities for analysing the demography of prehistoric communities.⁵⁹

1.2 METHODOLOGICAL APPROACH

Archaeological remains represent the only available source of information for the study of the structure and development of prehistoric societies. The most telling in that sense are cemeteries, which represent specific points in space where the deceased members of a community are "registered" in accordance with a certain set of rules and in a certain order. Encoded in cemeteries is the kinship or other connections between community members, and on a symbolic level a social cohesion and statuses of individual members. The funerary ceremonies and burial rituals consist of a series of rules and actions, through which social ties are being maintained, cultural patterns established and transmitted, and social memory as well as religious ideas are being kept alive and expressed, such as possible sacrifice, veneration of the ancestors, heroes, deities and so forth.⁶⁰ Only few traces of the prehistoric ritual have been preserved in the material form, most of them relating to:

⁵⁸ Tecco Hvala/Dular/Kocuvan 2004, 28 f, 66, 71, T. 7, 8, 96C, 105, 106.

⁵⁹ *Beiträge zur Archäozoologie und Prähistorischen Anthropologie* 1994; Hunter/Cox 2005.

⁶⁰ Humphreys/King (eds.) 1981; Gnoli/Vernant 1982; Hodder (ed.) 1982; Renfrew (ed.) 1984; Metcalf/Huntington 1985; Haffner 1989; Hodder (ed.) 1991; Clark (ed.) 1993; Davies 1997; Jensen/Nielsen (eds.) 1997; Chesson 2001.

- izbiro kraja pokopa in na prostorsko ureditev “mesta mrtvih”,
- način pokopa (sežig ali inhumacija),
- grobno konstrukcijo in grobna obeležja,
- pogrebno opravilo,
- daritvene predmete, povezane z izvajanjem grobnega rituala ali s simbolnim označevanjem družbene vloge pokojnika.

Za analize teh “matric” sta stanje terenskih raziskav in ohranjenost arheoloških ostalin nedvomno odločilnega pomena in pogojujejo izbiro metodologije za nadaljnja preučevanja. Na splošno bi raziskanost magdalenskogorske nekropole lahko ocenili kot zadovoljivo. Izkopavanja so zajela dobršen del prostora, kamor so nekoč pokopavali prebivalce naselbine na Magdalenski gori. Od 36 gomil, kolikor jih je vidnih v konfiguraciji terena, je bilo v celoti ali deloma raziskanih 24; od teh so jih okoli sedem razkrili na severnem delu nekropole na Laščiku, trinajst v skupini gomil na Prelogah in štiri na Voselci pri Hrastju ob jugovzhodnem vznožju naselja (sl. 1). Dejstvo pa je, da so bila izkopavanja osredotočena le na gomile, zato možnosti obstoja planih grobov ne moremo povsem izključiti. Tudi naselbina doslej še ni bila deležna sistematičnih raziskav; po velikosti se uvršča med največja naselja na območju jugovzhodnih Alp in meri približno 15 hektarjev, kar je mogoče določiti po umetnem preoblikovanju terena in utrdbenih strukturah, ki obkrožajo vrh in greben Magdalenske gore.⁶¹

Vendar je ohranjena dokumentacija o izkopavanjih precej skopa in pretežno opisne narave. Podatki o legi grobov v gomili in stratigrafskih odnosih so fragmentarni in v večini primerov ne omogočajo identifikacije mesta pokopa znotraj gomile. Še najboljše je dokumentirano raziskovanje gomile X (ohranjen je delni tloris) in gomile 13 na Prelogah, pa še v tem primeru so navedene globine grobov relativne, merjene od plašča gomile. Za določevanje faz pokopavanja in časovni razpon poselitve se tako lahko opremo v glavnem le na tipološko analizo predmetov in grobnih sestavov. Skupno je evidentiranih okoli 3515 najdb oziroma skupin predmetov in ohranjenih 656 grobnih celot (sl. 2), kar lahko označimo za dovolj reprezentativen vzorec. Najdbe so zelo raznolike, mnoge med njimi so bile obravnavane v okviru raznih tipoloških in kronoloških študij, o čemer bo tekla beseda v poglavjih, ki sledijo. Velika pozornost je bila namenjena izdelkom situlske umetnosti, ki jim pripada posebno mesto. Razen tega so bili izpostavljeni tudi nekateri kronološko najbolj izpovedni in najprestižnejši grobovi z Magdalenske gore, ki nakazujejo spremembe v materialni kulturi starejše železne dobe.

Kronološkega razvrščanja magdalenskogorskih grobov so se konec sedemdesetih in v osemdesetih letih prejšnjega stoletja lotili s klasično kombinacijsko metodo že Hencken, Bergonzijeva in Parzinger, vendar

⁶¹ Tecco Hvala/Dular/Kocuvan 2004, 13 ss, sl. 4, 7–10; Dular/Tecco Hvala 2007, 161 ss, sl. 88.

- the choice of the burial spot and structuring the “city of the dead”, i.e. necropolis,
- the burial rite (cremation or inhumation),
- grave construction and markers,
- funerary dress,
- objects offered to the deceased for the afterlife.

The key elements in analysing these “matrices” are certainly the state of field investigation and preservation of archaeological remains, since it is they that crucially dictate the methodological approach to further research. The state of investigation of the Magdalenska gora cemetery could be classified as generally satisfactory. The excavations have covered a large part of the burial area. Of the 36 tumuli identifiable from the configuration of the terrain, 24 were either completely or partly investigated; approximately seven of those in the northern part of the cemetery at Laščik, thirteen in a group of tumuli at Preloge and four at Voselca near Hrastje, at the south-eastern foot of the settlement hill (fig. 1). It has to be said that excavations concentrated on tumuli; therefore the existence of flat graves cannot entirely be excluded. The settlement has also not yet been systematically investigated. It extended roughly across 15 hectares, as indicated by the terraces and fortifications surrounding the summit and ridge of the hill of Magdalenska gora. In its size, the settlement ranks among the largest in the south-eastern Alpine area.⁶¹

In spite of the large extent of the tumuli investigated, however, the excavation documentation for the most part does not allow us to precisely locate the burials within the tumuli. The best documented of all is the investigation of Tumulus X (preserved partial ground plan) and Tumulus 13 at Preloge, and even there the grave depth is relative, measured from the surface of the tumulus mound. The phases of burial and chronological span can thus mainly be determined on the basis of the typo-chronological analysis of grave goods and grave groups. In total, approximately 3515 finds or sets of finds and 656 grave groups are recorded (fig. 2), which may be considered a representative enough sample. The finds are heterogeneous; many of them have already been featured in various typo-chronological studies, which will be discussed in the chapters below. Particular attention was paid to the products of the situla art, which hold a pride of place among the finds. Apart from those, some of the chronologically most revealing and prestige graves from Magdalenska gora were also specially treated, since they point to cultural changes in the Early Iron Age.

Attempts at a chronological classification of the Magdalenska gora graves were made in the late 1970s and in the 1980s by Hencken, Bergonzi and Parzinger using the classic combination method, but their work only included limited parts of the material available to

⁶¹ Tecco Hvala/Dular/Kocuvan 2004, 117 f, Abb. 4, 7–10; Dular/Tecco Hvala 2007, 161 ff, fig. 88.

le manjšega dela, ki jim je bil tedaj na razpolago.⁶² Zveze in izključevanja med posameznimi zvrstmi predmetov v grobnih celotah pa ne pomenijo zgolj kronoloških razlik. Da se v strukturi grobnih pridatkov in značilnih kombinacijah skrivajo še drugi pomeni, ki označujejo pripadnost določenemu spolu, starostni skupini, družbenemu statusu ali izražajo kulturne razlike, je izpostavila Teržanova v številnih študijah, v katerih je obravnavala različne noše oz. pogrebne oprave. Magdalenskogorske grobne celote iz Mecklenburške zbirke je vključila v svoj poskus rekonstrukcije halštatske družbene strukture v dolenskem kulturnem krogu (1985). Tudi Bergonzijeva je v analizi gradiva z Dolenske, ki ga hrani dunajski muzej, grobove obravnavala ločeno po skupinah glede na zastopanost orožja v njih.⁶³

Razen tega je Magdalenska gora vključena še v številne druge razprave in karte razprostranjenosti, ki se nanašajo na razširjenost posameznih kulturnih fenomenov in kažejo na lokalno provenienco ali na nadregionalne povezave ter kulturne stike med različnimi teritorialnimi skupnostmi.

Namen tega dela je na osnovi vsega evidentiranega gradiva z Magdalenske gore dopolniti in nadgraditi obstoječe analize v smislu razpoznavanja družbene strukture te skupnosti in njenih običajev.

them at the time.⁶² Connections and exclusions between individual types of objects with regard to the grave groups signify more than just chronological differences; the structure of grave goods and typical combinations may also reveal sex, age group, social status or cultural differences, as was pointed out by Teržan in numerous studies in which she analysed various costumes or funerary dress. When attempting a reconstruction of the Hallstatt social structure in the Dolenska cultural circle (1985), Teržan also considered the grave groups from Magdalenska gora, those which form part of the Mecklenburg Collection. Bergonzi, on the other hand, analysed the material from Dolenska kept at the Natural History Museum in Vienna and treated the graves in separate groups according to the presence or absence of weapons.⁶³

Magdalenska gora was also featured in numerous distribution maps showing the extent of individual cultural phenomena; some are locally delimited while others cover vast expanses and represent interregional connections and cultural contacts between different territorial communities.

The aim of this book is, on the basis of all the recorded material from Magdalenska gora, to supplement and upgrade these analyses in the sense of recognizing the social structure and customs of the community.

⁶² Hencken 1978, Charts 1-4; Bergonzi 1981, Tab. A in C; Parzinger 1988, Taf. 158-159.

⁶³ Bergonzi 1981, 17 ss, Tab. B in D; Teržan 1978; ead. 1984a; ead. 1985; ead. 1986; ead. 1992a; ead. 1992b; ead. 1995b itd.

⁶² Hencken 1978, Charts 1-4; Bergonzi 1981, Tab. A and C; Parzinger 1988, Taf. 158-159.

⁶³ Bergonzi 1981, 17 ff, Tab. B and D; Teržan 1978; ead. 1984a; ead. 1985; ead. 1986; ead. 1992a; ead. 1992b; ead. 1995b etc.

2 KULTURNO-KRONOLOŠKI OKVIR

2 CULTURAL AND CHRONOLOGICAL OUTLINE

Utrjeno naselje z dominantno geografsko lego in gomilna grobišča v neposredni okolici so tipičen izraz in pojavne oblike halštatske kulture na jugovzhodnoalpskem prostoru. Skupnosti, ki so v starejši železni dobi živele na Dolenjskem in v Beli krajini, so združevali svojski pogrebni običaji, ki se manifestirajo v skeletnih grobovih znotraj gomil družinsko-rodovnega tipa, v značilnih opravah umrlih ter v običaju prilaganja orožja v grob. Po teh karakteristikah se razlikujejo od drugih sočasnih kulturnih skupin na ozemlju današnje Slovenije.

Gabrovec je v tem prostoru prepoznal pet regionalnih entitet, ki jih je poskušal utemeljiti že leta 1964 in jih tudi pozneje v bistvu ni spreminjal (*sl.* 9).⁶⁴ Med njimi je izpostavil predvsem svetolucijsko in dolenjsko halštatsko skupino, kamor sodi tudi Magdalenska gora. Njegovi kulturno-teritorialni delitvi so sledile študije drugih slovenskih arheologov, ki so posamezne skupine še bolj poglobljeno obdelali in kronološko razčlenili.⁶⁵

Njegov koncept je v jedru povzel tudi Hencken v svoji publikaciji o magdalenskogorski nekropoli (1978), čeprav je v kratkem poglavju o železni dobi v Sloveniji uporabil nekoliko drugačno formulacijo in delitev na sedem kulturnih skupin. Za svetolucijsko skupino na severozahodu je dopustil možnost, da je spadala v venetsko cono; skupino na Gorenjskem je povezoval s svetolucijsko; na vzhodnem delu omenja spodnještajersko skupino, ki je segala še na področje avstrijske Štajerske in na severovzhod Hrvaške; na jugozahodu pa svojski skupini v Istri in na Notranjskem. Na območju današnje Bele krajine je izpostavil Vinico, pri čemer je poudaril, da je v halštatskem času po glavnih značilnostih pripadala kulturni skupini na Dolenjskem, v latenskem obdobju pa je predstavljala specifičen izraz japonske kulture. Podzemelj je uvrstil v dolenjsko kulturno skupino, ki jo je označil za najpomembnejšo, s središči v Stični, na

A fortified settlement on a dominant location with tumulus cemeteries at its feet represents a typical physical expression of the Hallstatt culture in some regions of the south-eastern Alps, among them Dolenjska and Bela krajina. The communities living there in the Hallstatt period shared a particular set of funerary customs, manifested in inhumation burials into tumuli presumably intended for members of a family or clan, but also in typical funerary dress and the custom of laying weapons in graves. In these characteristics they differ from other contemporary cultural groups in their vicinity.

In the territory of the present-day Slovenia, Gabrovec identified five regional entities already in 1964 and did not significantly alter the conception in later years (*fig.* 9).⁶⁴ The more prominent of those entities were the Sveta Lucija (S. Lucia) and Dolenjska Hallstatt groups, whereby Magdalenska gora belonged to the latter. His cultural and territorial division was followed up by numerous studies of other Slovenian archaeologists, who further analysed and divided the chronological development of individual groups.⁶⁵

Gabrovec's concept was largely adopted also by Hencken in his publication of the Magdalenska gora cemetery (1978), though his short chapter on the Iron Age of Slovenia contains a slightly different formulation and a division into seven cultural groups. For the Sveta Lucija group in the north-west, he allowed the possibility of forming part of the Venetic zone; the group in Gorenjska was allied to the Sveta Lucija group; in eastern Slovenia he mentioned Lower Styria/Štajerska group, which extended in Austrian Styria and north-eastern Croatia; while he recognized particular groups in Istria and Notranjska in the south-west. In the present-day Bela krajina, he particularly mentioned Vinica, emphasizing that in the Hallstatt period it belonged to the cultural group of Dolenjska in its main traits, while in the La Tène period it represented a specific expression of the Iapodic culture.

⁶⁴ Gabrovec 1964, 219 ss; *id.* 1964–1965a, 25 ss (=1966a, 5 ss); *id.* 1975a; *id.* 1987; *id.* 1999, sl. 1.

⁶⁵ Halštatsko obdobje v Sloveniji. – *Arheološki vestnik* 24 (1973) 1975, 303 ss; Guštin 1979; Teržan 1990a; Dular J. 2003; Dular/Tecco 2007.

⁶⁴ Gabrovec 1964, 219 ff; *id.* 1964–1965a, 25 ff (=1966a, 5 ff); *id.* 1975a; *id.* 1987; *id.* 1999, Abb. 1.

⁶⁵ Hallstattzeit in Slowenien. – *Arheološki vestnik* 24 (1973) 1975, 303 ff; Guštin 1979; Teržan 1990a; Dular J. 2003; Dular/Tecco 2007.

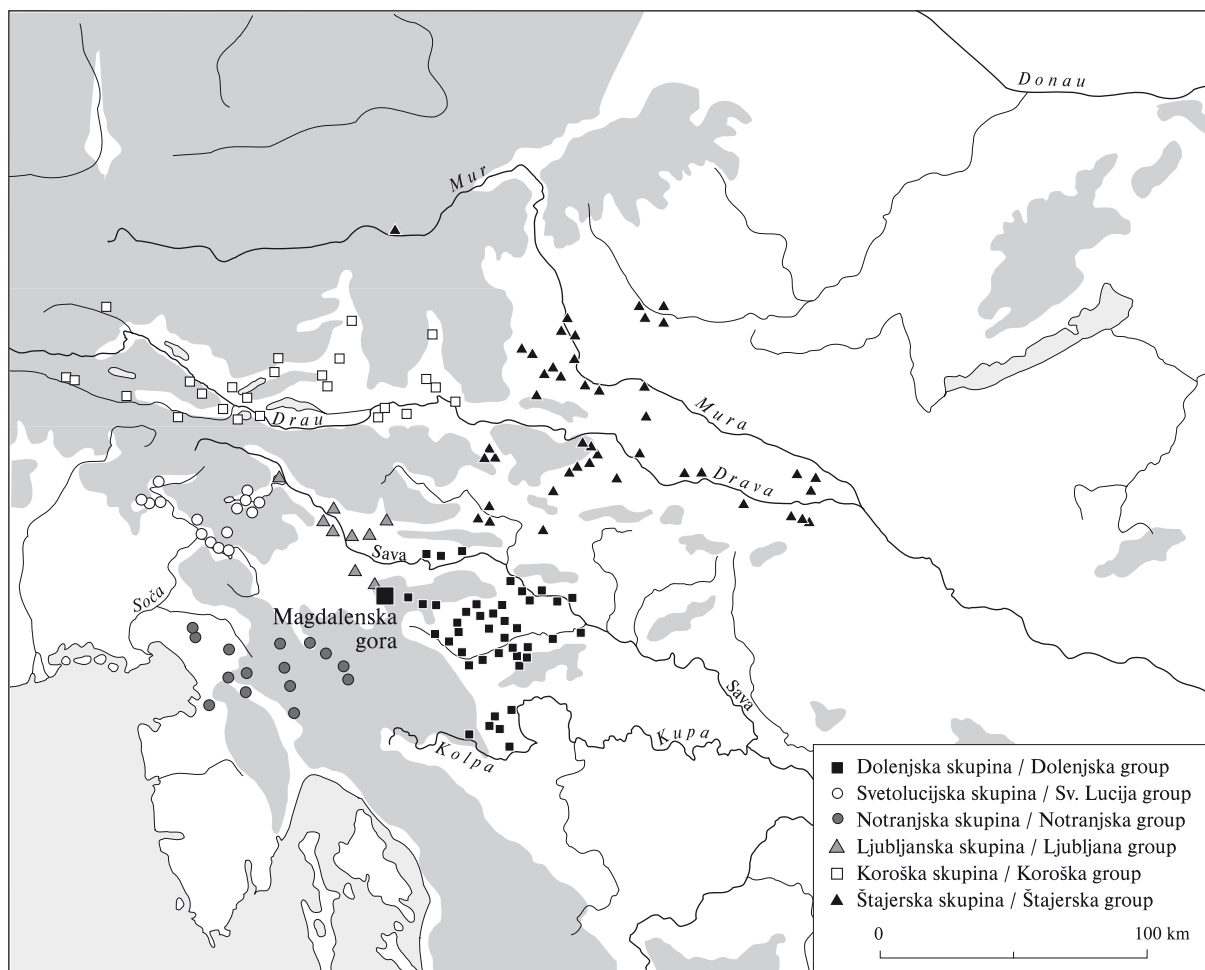

Sl. 9: Geografska lega Magdalenske gore v odnosu do halštatskih kulturnih skupin na jugovzhodnoalpskem prostoru (po Gabrovcu 1999).

Fig. 9: Geographic position of Magdalenska gora in relation to the Hallstatt cultural groups in the south-eastern Alpine area (after Gabrovec 1999).

Magdalenski gori, Gradišču, Vačah, Velikem Vinjem vrhu oz. Šmarjeti, Mokronogu in Novem mestu.⁶⁶

Z drugega zornega kota se je kulturne regionalizacije lotil Hermann Parzinger v svoji študiji *Chronologie der Späthallstatt- und Frühlatène-Zeit* (1988). Prostor med rekama Mosel in Sava je na osnovi razlik v fondih grobnih najdb razdvojil na severozahodno- in jugovzhodnoalpski kulturni krog, oba pa še na manjše regije. Jugovzhodnoalpski krog je nadalje delil na zahodnoslovenske skupine, kamor je uvrstil posoško, notranjsko in gorenjsko skupino; med vzhodnoslovenskimi skupinami pa je razločeval zahodno in vzhodno dolensko ter belokranjsko skupino. Magdalensko goro je skupaj s Stično, Vačami in Javorjem obravnaval kot zahodno dolensko skupino.⁶⁷

Ne glede na razlike v poimenovanju in delitvah je mesto Magdalenske gore v vseh regionalnih členitvah

He set Podzemelj into the Dolenjska cultural group, which he designated as the most important among the groups, with centres at Stična, Magdalenska gora, Gradišče, Vače, Šmarjeta, Mokronog and Novo mesto.⁶⁶

Parzinger offered a different view of the cultural regionalisation in his 1988 book entitled *Chronologie der Späthallstatt- und Frühlatène-Zeit*. On the basis of differences discernible in the fund of grave finds, he divided the area between the rivers Mosel and Sava into the North-Western and South-Eastern Alpine cultural circle, each of which were further subdivided. The latter circle was subdivided into Western Slovenian groups, with the Soča Valley, Notranjska and Gorenjska subgroups, and Eastern Slovenian groups with Eastern Dolenjska, Western Dolenjska and Bela krajina subgroups. Magdalenska gora, together with Stična, Vače and Javorje, formed part of the Western Dolenjska subgroup.⁶⁷

⁶⁶ Hencken 1978, 3 ss, Fig. 1.

⁶⁷ Parzinger 1988, 4 s in 27 ss, Taf. 1: 1.

⁶⁶ Hencken 1978, 3 ff, Fig. 1.

⁶⁷ Parzinger 1988, 4 f and 27 ff, Taf. 1: 1.

trdno zasidrano v dolenski kulturni skupini. Ob tem želim poudariti le, da se v razpravi opiram na Gabrovčevu opredelitev, ko se sklicujem na dolensko halštatsko skupnost (*sl.* 9).

V kronoloških analizah razvoja dolenske halštatske skupnosti so magdalenskogorske najdbe odigrale vidno vlogo. Na tem mestu ne bom posegala v dolgo zgodovino nastajanja kronoloških shem, pač pa se bom omejila le na tisti del, ki je relevanten za nadaljnjo razpravo. Pomemben mejnik je prvi Gabrovčev poskus podrobnejše členitve starejše železne dobe na Dolenjskem, ki ga je predstavil leta 1963 na arheološkem kongresu v Ljubljani, ko večji del izkopanega gradiva še ni bil objavljen. Pri utemeljevanju razvoja v mlajšem halštatskem obdobju (Ha D) se je v delitvi na horizonta skitskih vplivov in negovskih čelad opiral prav na nekatere grobne celote z Magdalenske gore. Kasneje (1971) sta skupaj z Ottom-Hermanom Freyem predlagala novo poimenovanje in razdelitev tega obdobja, ki sta ga razčlenila na zaporedne stopnje dvogrebenastih čelad, certoških fibul in negovskih čelad.⁶⁸

Na to kronološko shemo se je naslonil tudi Hencken (1978) pri časovni razvrstitvi grobnih celot z Magdalenske gore, ki jih hrani Peabodyjev muzej. Pokope je umestil v posamezne časovne sekvence, dolge približno 50 let, pri čemer se je držal poimenovanja, kot sta ga predložila Gabrovec in Frey; ob tem je negovski horizont razdelil na dve fazi. Leto poprej je izšla študija Bibe Teržan o certoških fibulah, kjer je avtorica na osnovi analize grobov iz gomil v Volčjih njivah in Dolenjskih Toplicah ter po vodilnih oblikah fibul razčlenila mlajše halštatsko obdobje na stopnji kačastih in certoških fibul, hkrati je nakazala delitev certoške in negovske stopnje na starejši in mlajši del. Četudi med Hencknom in Teržanovo ni večjih razhajanj glede trajanja faz negovske stopnje v absolutnem kronološkem smislu, pa obstajajo temeljne vsebinske razlike (*sl.* 10). Gre za to, da je Hencken postavil najprestižnejše moške pokope z negovskimi čeladami in zgodnjelatenski meči v mlajšo fazo te stopnje, medtem ko jih je Teržanova datirala v starejšo fazo in prepričljivo pokazala, da je bila v mlajši fazi halštatska kultura na Dolenjskem že v zatonu, kar je jasno razvidno tudi iz njenih komentarjev v recenziji Hencknove knjige.⁶⁹ Na *sl.* 10 so prikazani reprezentativni grobovi po gomilah in njihovo kronološko mesto, kakor so jih razvrstili posamezni avtorji; razhajanja med njimi so podčrtana.

Leta 1981 je izšla razprava Giovanne Bergonzi, v kateri obravnava območje jugovzhodnih Alp in severne

As seen from the above, different authors proposed different names and divisions, though all of them placed the site of Magdalenska gora firmly within the cultural group of Dolenjska. The conception of the Dolenjska Hallstatt group or community in this publication is based on that proposed by Gabrovec (*fig.* 9).

The finds from Magdalenska gora played an important role in the chronological analyses of the development of the Dolenjska Hallstatt community. The evolution of the chronological schemes enjoys a long history, of which only the part relevant for further discussion will be presented here.

An important milestone is the first attempt by Gabrovec at a more detailed division of the Early Iron Age in Dolenjska, which he presented at an archaeological congress held in Ljubljana in 1963. At that time, the excavated material from the period was for the most part unpublished. His discussion concerning the development during the Late Hallstatt period and division on the horizons of Scythian influence and Negova helmets was based on some of the grave groups from Magdalenska gora. In 1971, Gabrovec together with Frey proposed a new name and subdivision into successive phases of double-crested helmets, Certosa fibulae and Negova helmets.⁶⁸

This chronological scheme was adopted also by Hencken in 1978 when classifying the grave groups from Magdalenska gora now kept at the Peabody Museum. He set the burials into roughly 50 years long chronological sequences, using the names proposed by Gabrovec and Frey. The only addition was to divide the Negova horizon into two phases. A year earlier, Teržan published her study on Certosa fibulae, in which she included the graves from the tumuli at Volčje njive and Dolenjske Toplice and was able, based on the leading forms of the fibulae, to suggest a division of the Late Hallstatt period into the phases of serpentine and Certosa fibulae, as well as the division of the Certosa and Negova phases into respective early and late parts. There are no major differences between Hencken and Teržan as far as the duration of the phases in absolute terms is concerned, while the differences in the content are fundamental (*fig.* 10). For example, Hencken set the most prestigious male burials with Negova helmets and Early La Tène swords into the late part of the Negova phase, while Teržan dated them to the early part and convincingly argued that the Hallstatt culture in Dolenjska had already been in decline in the late part, which is clearly discernible also from her comments in the review of Hencken's book.⁶⁹

⁶⁸ Gabrovec 1964–1965a, 29 ss; *id.* 1966a, 15 ss; Frey/Gabrovec 1971.

⁶⁹ Teržan 1976, 383 ss, *sl.* 59; Hencken 1978, 83 ss, chart 1–4; Teržan 1981.

⁶⁸ Gabrovec 1964–1965a, 29 ff; *id.* 1966a, 15 ff; Frey/Gabrovec 1971.

⁶⁹ Teržan 1976, 383 ff, *Abb.* 59; Hencken 1978, 83 ff, charts 1–4; Teržan 1981.

Stopnje po / Phases after			Gom./Tum. II			Gom./Tum. P 2				V 2	Gom./Tum. IV			Gom./Tum. V			
H	P	T&G	H	P	T	G	H	B	P	B	H	P	T	G	H	P	T
Podzemelj		Podzemelj															
	I		2	1								14					
Stična	1	Stična															
	2		1	2	1a	1a	1a					3					
Double-crest. helmets	IV	Kačaste fibule															
			2	2	2a	2a	57		54 48 38 13		12	2 13 34 49	24 2 13 34 49	34			
Certosa fibulae	V	fibule															
			1	1	3		37 58		15 27 30 39 52 53	42	58 65 68 83	9	34 41 48				
VI	Certoške fibule	2															
			10	10		46 38 13 p		38	55 40 25 17 4		11 18 17 20 21	22 25 17	1 26 16 30		2 26 28 37	28 37 23	23 31 43
Negova helmets	1	VII	čelade	1													
					4		21	1-2			1-2 3 6 5		23	1 19 38	38	6-7 19-20 29	23 36
VIII	2	Negovske	2														
				5 21	5	4		1-2					31 21 32 52	31		6-7 19-20 29 26a 11 39	19-20

Sl. 10: Kronološka opredelitev posameznih grobov iz gomil na Magdalenski gori, kakor so jih razvrstili razni avtorji.

Ležeče = grobovi brez orožja; **poudarjeno** = grobovi z orožjem; podčrtano = diskrepanca v kronološki opredelitvi.

B = Bergonzi 1981; **G** = Gabrovec 1987; **H** = Hencken 1978; **P** = Parzinger 1988; **T** = Teržan 1976 in 1981.

P 2 = Preloge, gomila 2; **V 2** = Voselca, gomila 2.

Italije okoli 5. st. pr. n. št. Med gradivom, ki ga je predstavila z našega prostora, so v precejšnji meri zastopane najdbe z Magdalenske gore, in sicer iz gomil 2 in 13 na Prelogah ter gomile 2 z Voselce pri Hrastju, ki jih hrani dunajski Naravoslovni muzej. V poglavju o relativni kronologiji za Dolenjsko je upoštevala Gabrovčevo in Freyjevo kronološko shemo s stopnjo dvogrebenastih čelad. Ob tem je na več mestih poudarila, da gre za objavo teme, ki jo obdelala že leta 1971, zato je kasnejša spoznanja le deloma upoštevala.⁷⁰ Oprave je analizirala v dveh ločenih sklopih, v prvem je zajela sestave pridatkov brez orožja, v drugem z orožjem. Pri tem je opozorila, da je delitev certoške stopnje na dve fazi možna le v skupini grobov brez orožja, medtem ko v pokopih z orožjem ni izražena. Ravno nasprotna situacija se kaže v negovski stopnji, ki je prepoznavna skoraj izključno v moških opravah z orožjem, medtem ko je spremembe v ženski noši, ki bi označevale negovsko stopnjo, težje razločiti. Na preglednici (sl. 10) so grobovi brez orožja označeni z ležečo pisavo, grobovi z orožjem pa poudarjeno.

Podobno diskrepanco lahko opazimo tudi v Parzingerjevi študiji iz leta 1988. Zgodnejši fazi v okviru mlajšega halštatskega obdobja je utemeljeval le z ženskimi grobovi (sl. 10). Njegov koncept periodizacije poznahalštatskega in zgodnjelatskega obdobja je zgrajen na svojstvenem metodološkem pristopu. Izhajal je iz določevanja razvojnih faz znotraj posameznih najdišč, ki jih je nato sinhroniziral v okviru regionalnih skupin in jih na koncu povezal v enotne časovne horizonte, ki družijo prostor med rekama Mosel in Savo. Pokope v magdalenskogorske gomile je razdelil na 8 faz, pri čemer se je opiral na gradivo, objavljeno pri Hencknu, ter na manjši izbor objavljenih grobnih celot iz gomile 2 in 13 v dunajski prazgodovinski zbirki.⁷¹ V oceni njegove študije je Teržanova opozorila, da različne kombinacije grobnih pridatkov ne pomenijo nujno kronoloških razlik.⁷²

Gabrovec je v sintezi železne dobe na območju jugovzhodnih Alp in zahodne Panonije, ki jo je napisal za peti zvezek *Praistorija jugoslavenskih zemalja* (1987), poskušal bolj uravnoteženo predstaviti tako moško kot žensko nošo po posameznih stopnjah, kljub temu pa je z Magdalenske gore izpostavil predvsem vodilne moške grobove. V delitvi mlajšega halštatskega obdobja je v celoti sprejel argumente Teržanove. V takšni obliki je relativna kronološka shema za dolenjsko skupino v slovenski arheologiji v veljavi še danes.⁷³ Pod vplivom novih naravoslovnih metod datiranja (dendrološke in radiokarbonske) je v zadnjem času doživela nekaj korekcij v smislu absolutnih datumov. Paul Gleirscher (2006) je tako pomaknil Gabrovčevo stopnjo Ljubljana IIa v čas pred letom 800, stopnji Ljubljana IIb oz. Podzemelj 1

To illustrate, *fig. 10* gives the most representative graves in individual tumuli in relation to the chronological place attributed to them by various authors, the differences among them being underlined.

Another author dealing with the subject was Bergonzi, who published a paper in 1981 that treated the area of south-eastern Alps and northern Italy roughly during the fifth century BC. The material she considered from Slovenia includes numerous finds from Magdalenska gora, namely from Tumuli 2 and 13 at Preloge and Tumulus 2 at Voselca near Hrastje, all kept at the Natural History Museum in Vienna. Her relative chronology for Dolenjska was based on that proposed by Gabrovec and Frey with the double-crested helmet phase, whereby she stated in several places that her analysis had been done in 1971 and later findings were only partially considered.⁷⁰ She analysed the costumes with and those without weapons separately. She found that the division of the Certosa phase into two parts is possible only for the group of graves without weapons, while the group with weapons does not reveal such a division. The opposite situation was observed for the Negova phase, which is visible almost exclusively in the male costumes with weapons, while the changes in the female costume that would mark the Negova phase are harder to distinguish. The table on *fig. 10* shows graves without weapons in italic and those with weapons in bold.

A similar discrepancy can be observed in Parzinger's study from 1988. The two earliest phases within the Late Hallstatt period were based on female graves only (*fig. 10*). His concept of periodization of the Late Hallstatt and Early La Tène periods is constructed on a particular methodological approach, based on determining development phases of individual sites, which were then synchronized within regional groups and finally related into uniform chronological horizons that tied the area between the rivers Mosel and Sava. Parzinger grouped the burials in the tumuli of Magdalenska gora into eight phases based on the material published by Hencken and a small selection of the published grave groups from Tumuli 2 and 13 in the Viennese prehistoric collection.⁷¹ When reviewing his study, Teržan pointed out that different combinations of grave goods do not necessarily signify chronological differences.⁷²

In 1987, Gabrovec wrote a synthesis of the Iron Age in south-eastern Alps and western Pannonia, published in the fifth volume of *Praistorija jugoslavenskih zemalja*. In it he attempted to give a more balanced presentation of the male and female costume in individual phases, though Magdalenska gora was presented mainly through the leading male graves. For the division of the Late Hallstatt period, he entirely accepted the arguments proposed by Teržan and it is in this form that the rela-

⁷⁰ Bergonzi 1981.

⁷¹ Parzinger 1988, 27 ss, Taf. 33–37, 158–159.

⁷² Teržan 1992b, 70.

⁷³ Gabrovec 1987; Dular J. 2003, sl. 51.

⁷⁰ Bergonzi 1981.

⁷¹ Parzinger 1988, 27 ff, Taf. 33–37, 158–159.

⁷² Teržan 1992b, 70.

pr. n. št. BC	Zahodnohalštatska kultura West Hallstatt Culture		Ljubljana	Dolenjska	Veio
	Dendro-datumi Dendro data	Kossack Hennig	Gleirscher 2006	Gabrovec, Teržan 2008	Bartoloni, Gambari
-850			Ljubljana I b		
		Ha B 3			I C
813 Chindrieux			Ljubljana II a		
-800				Podzemelj 1	II A
		Ha C 0	Ljubljana II b		
778±5 Wehringen I/8				Podzemelj 2	II B
-750			Ljubljana III a		II C
		Ha C 1		Stična 1	Orientalizzante antico
667±10 Dautmergen I, c.g.					
-650		Ha C 2		Stična 2	Orientalizzante medio
616 Magdalenenberg gr. 1				1	
-600		Ha D 1		Kačaste fibule Serpentine fibulae	
				2	
520 Heuenburg SZ vrata, faza Ia NW gate, phase Ia		Ha D 2-3		1	
-500				Certoške fibule Certosa fibulae	
				2	
-450				1	
		Lt A		Negovske čelade Negova helmets	
-400				2	
-350					

Sl. 11: Kronološka shema dolenjske halštatske skupnosti (po Gabrovec/Teržan 2008 in Gleirscher 2006).

Fig. 11: Chronological scheme of the Dolenjska Hallstatt community (after Gabrovec/Teržan 2008 and Gleirscher 2006).

pa sinhroniziral s stopnjo Ha C1a oz. Ha C0 v smislu korigirane srednjeevropske kronologije. V razpravah o stiških gomilah je Teržanova predstavila novo absolutno kronološko sliko halštatskega obdobja na Dolenjskem, ki jo na eni strani vzporeja z dendrološkimi datumi s švicarskih kolišč ter kronološko delitvijo zahodnohalštatske kulture, na drugi strani pa s periodizacijo etruščanskega Veio. Največji so časovni premiki faz starohalštatskega obdobja, medtem ko je za mladohalštatsko obdobje nova predvsem delitev kačaste stopnje na dve fazi (*sl. 11*).⁷⁴

tive chronological scheme for the Dolenjska group is still valid in Slovenian archaeology.⁷³ Its absolute dates have seen some corrections in recent years, brought about by new scientific dating methods (dendrochronological and radiocarbon). Gleirscher (2006) thus set Gabrovec's Ljubljana IIa phase back before 800 BC and synchronized phases Ljubljana IIb or Podzemelj 1 with Ha C1a or Ha C0 in the sense of the corrected central European chronology. When discussing the tumuli at Stična, Teržan presented a new absolute chronological picture of the Hallstatt period in Dolenjska, which she correlated with the dendrochronological dates from the Swiss pile-dwelling sites and the chronological division of the West Hallstatt culture, on the one hand, and the periodization of the Etruscan city of Veio, on the other. The most important shifts of phases that occurred are those of the Early Hallstatt period, while for the Late Hallstatt period mainly the division of the Serpentine Fibulae phase into two parts is new (*fig. 11*).⁷⁴

⁷⁴ Teržan 2008, 275 ss, sl. 42.

⁷³ Gabrovec 1987; Dular J. 2003, Abb. 51.

⁷⁴ Teržan 2008, 275 ff, Abb. 42.

3 POGREBNI OBIČAJI

3 FUNERARY CUSTOMS

3.1 LEGA IN STRUKTURA GROBIŠČ

Magdalenskogorsko “mesto mrtvih” (*necropolis*) obeležujejo gruče gomil severno od naselja na Laščiku in na Prelogah ter ob jugovzhodnem vznožju na Voselci. Razpostavljene so bile kot vidna znamenja najbrž ob nekdanjih poteh, ki so vodile h glavnima vhodoma v utrjeno naselbino (*sl. 12: A*). Takšen koncept prostorske ureditve in težnja po monumentalnosti pa nista značilna samo za Dolenjsko in Belo krajino v starejši železni dobi. Gomilna grobišča so znana tudi drugod, vendar so v grobnem kultu med kulturnimi regijami obstajale znatne razlike. Na območju severnojadranskega in vzhodnoalpskega polmeseca so v tistem času preminule v glavnem sežigali in jih pokopavali bodisi v plana grobišča bodisi v gomile s kamnitimi kamrami, medtem ko je za dolensko skupnost značilno pokopavanje trupel pokojnikov v grobove, ki so praviloma krožno razporejeni okoli središča gomile.⁷⁵

Natančnejši vpogled v zgradbo dolenskih in belokranjskih gomil so dala modernejša izkopavanja gomil v Stični, Novem mestu, Metliki in na Budinjaku.⁷⁶ Na Magdalenski gori tako jasne slike ni mogoče izrisati.

⁷⁵ *Plana grobišča z žganimi pokopi*: Posočje in ponekod na Gorenjskem; *gomile z žganim pokopom*: Koroška in nekateri kraji na Gorenjskem, Štajerska in vzhodna Panonija; *mešan pokop* (žgan ali skeleten, plan ali gomilni): Notranjska. V Istri je zastopan *žgan pokop v preprosto grobno jamo ali v kamnito skrinjo* znotraj ali zunaj obzidja naselbin. *Gomile s skeletnimi pokopi* pa so poleg Dolenjske značilne predvsem za območji Glasinac v Bosni in Mati v Albaniji. Glej prispevke kolokvija Halštatsko obdobje v Sloveniji – *Arheološki vestnik* 24, 1973 in v *Praistoriji jugoslavenskih zemalja* 5, 1987, ter še Gabrovec 1999, 178 ss. Skeletni pokopi v gomilah ali znotraj grobnih parcel se prav tako pojavljajo na Apeninskem polotoku: glej razprave v Naso (ur.) 2011; Beinhauer 1985, 26 ss, Abb. 4.

⁷⁶ Knez 1986, T. 62–65; *id.* 1993, pril. 2; Breščak/Križ 1987; Križ 1991; *id.* 1997, pril. 1,2; *id.* 2000, pril. 2; Škoberne 1999, sl. 6–22, 26, 27; Dular J. 2003, sl. 50; Gabrovec *et al.* 2006, pril. 1 in 3; Gabrovec/Teržan 2008, 34 ss, 233 ss, sl. 18.

3.1 CEMETERY LAYOUT AND STRUCTURE

The “city of the dead” at Magdalenska gora is composed of clusters of tumuli north of the settlement at Laščik and Preloge, as well as along the south-eastern foot of the settlement hill at Voselca, whereby the tumuli were disposed as visual markers along former roads that led to the two main entrances into the fortified settlement (*fig. 12: A*). Such a layout as well as a tendency towards monumentality is own not only to Dolenjska and Bela krajina in the Early Iron Age, but to other cultural regions as well, though considerable differences existed in the funerary cult. In the area of the northern Adriatic and the eastern Alps, the dead were mainly cremated and buried either in flat cemeteries or in tumuli with stone chambers. Characteristic of the Dolenjska community, on the other hand, are inhumation burials into graves usually encircling the centre of the tumulus.⁷⁵

The structure of the tumuli in Dolenjska and Bela krajina became better known with the modern excavations at Stična, Novo mesto, Metlika and Budinjak.⁷⁶ For Magdalenska gora, however, such a clear picture cannot be given.

⁷⁵ *Flat cemeteries with cremation burials*: the Soča Valley and somewhere in Gorenjska; *tumuli with cremation burials*: Koroška (Carinthia), Štajerska (Styria) and eastern Pannonia; *mixed burials* (cremations or inhumations, flat or tumulus cemeteries): Notranjska; *cremation burials in grave pits or in stone cists within or outside settlement walls*: Istria; *tumuli with inhumation burials* are characteristic of Dolenjska as well as at Glasinac (Bosnia) and Mati (Albania). See proceedings of the Hallstattzeit in Slowenien colloquium – *Arheološki vestnik* 24, 1973 and *Praistorija jugoslavenskih zemalja* 5, 1987; see also Gabrovec 1999, 151 ff. Inhumation burials in tumuli or within burial plots also appear on the Apennine Peninsula: see treatises in Naso (ed.) 2011; Beinhauer 1985, 26 ff, Abb. 4.

⁷⁶ Knez 1986, T. 62–65; *id.* 1993, Beil. 2; Breščak/Križ 1987; Križ 1991; *id.* 1997, App. 1,2; *id.* 2000, App. 2; Škoberne 1999, figs. 6–22, 26, 27; Dular J. 2003, Abb. 50; Gabrovec *et al.* 2006, Beil. 1, 3; Gabrovec/Teržan 2008, 34 ff, 233 ff, Abb. 18.

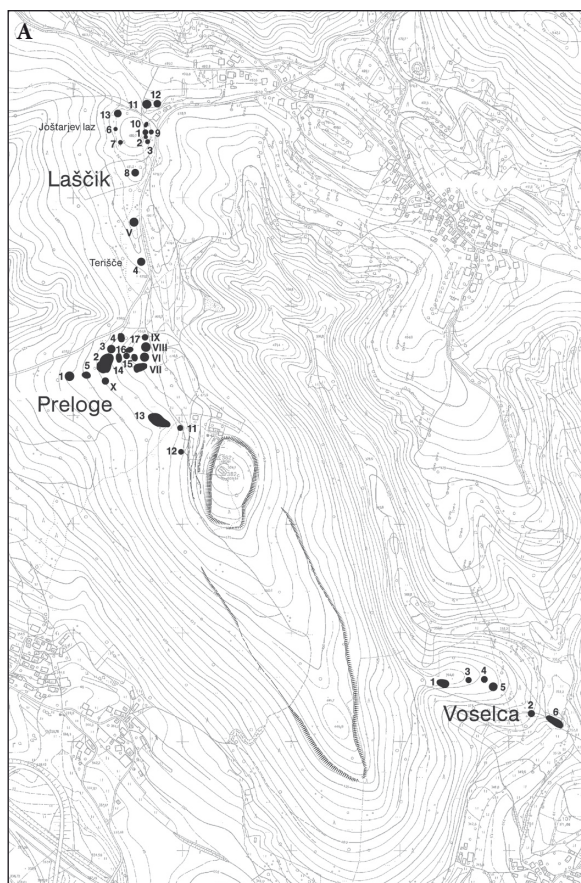

B

Gomila Tumulus	Št. gr. No. of gr.	Pokop / Burial rite			
		žgan cremation	skeleten skeletal	s konjem with horse	neznan unknown
L 1-3,10	18	5	4		9
L 4	3	1	2		
L 8	4	3			1
L 9	3	2	1		
L 11	1	1			
L 12	1	1			
L V	52		47	3	5
P I	6	1			5
P II	26		4	1	22
P III	8	1			7
P IV	66	4	25	4	37
P VI	48	33	12		3
P VII	53	15	35	1	3
P VIII	22	4	15		3
P IX	6	ni podatkov / no data			
P X	78	2	76		
P 2	103		59	3	44
P 3	3	3			
P 5	1		1		
P 13	175	16	156	1	3
V 1	2		2		
V 2	25	7	9		9
V 5	1	1			
V 6	3?	2?			1
Skupaj Total	708	102	448	13	152

Sl. 12: A – Struktura grobišč na Magdalenski gori; B – število grobov in načini pokopov v posamičnih gomilah (po Tecco Hvala/Dular/Kocuvan 2004, sl. 4 in 44).

Fig. 12: A – Structure of the cemeteries at Magdalenska gora; B – number of graves and burial rite in individual tumuli (B) (after Tecco Hvala/Dular/Kocuvan 2004, Abb. 4 and 44).

3.2 NAČIN POKOPA

Po podatkih izkopavalcev so v magdalenskogorskih gomilah prevladovali skeletni grobovi (sl. 12: B), ki so ležali v različnih smereh, nekateri bližje sredini gomile, drugi bolj na obrobju. V grobu je bila običajno pokopana ena oseba v iztegnjeni legi na hrbtu, odeta v pogrebno opravo z nakitom ali orožjem, izjemoma tudi s konjsko opremo ali celo s konjem. Ob tem je bilo zabeleženih okoli sto žganih pokopov.

3.2.1 ŽGANI POKOPI

O legi žganih grobov

Na žgane pokope so naleteli pri kopanju gomil na vseh treh lokacijah – na Laščiku, Prelogah in Voselci; nekatere so tudi risarsko ali fotografsko dokumentirali (sl. 13, 17, 18). Ob njih so mestoma odkrili zanimive strukture iz kamna, kot poročja Goldberg v zvezi z go-

3.2 BURIAL RITE

The information recorded by the excavators at Magdalenska gora reveals that the predominant rite was inhumation (fig. 12: B), whereby the burials were variously orientated, some lying closer to the centre and others more on the periphery. The graves usually contained a single individual, lying stretched out on his or her back and wearing a funerary dress with jewellery or weapons, in exceptional cases even buried with horse gear or the horse itself. Alongside inhumations, roughly a hundred cremations were also recorded.

3.2.1 CREMATION BURIALS

On the position of cremations

Cremation burials were found on all three parts of the cemetery – Laščik, Preloge and Voselca; some of them even documented in drawing or on a photograph



Sl. 13: Vrsta žganih grobov s pokrivno kamnito ploščo v gomili VI na Prelogah, odkritih v okviru izkopavanja vojvodinje Mecklenburška (na sliki) (po Hencknu 1978, Fig. 177 in 185).

Fig. 13: Row of cremation graves covered by stone slabs, found in Tumulus VI at Preloge during the excavation by the Duchess of Mecklenburg (in photo) (after Hencken 1978, Figs. 177 and 185).

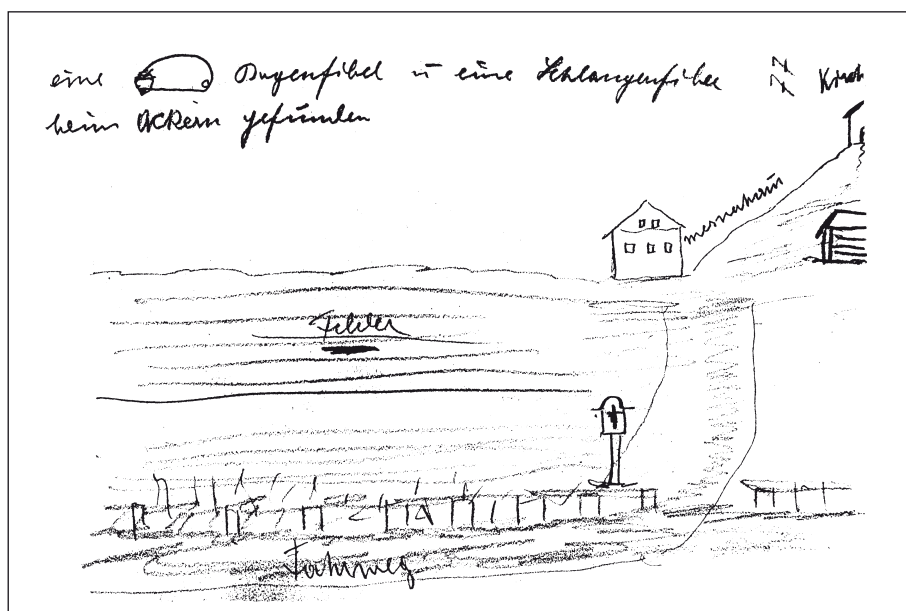

Sl. 14: Szombathyjeva skica območja najdb (po Tecco Hvala/Dular/Kocuvan 2004, sl. 23).

Fig. 14: Szombathy's sketch of the findspot (after Tecco Hvala/Dular/Kocuvan 2004, Abb. 23).

milo VI na Prelogah, kjer je menda v južnem predelu gomile stalo v krogu 50 raznobarnih kamnov, velikih kot pest ali glava. Severno in južno od tega kamnitega venca je bilo razvrščenih šest žarnih grobov, pokritih s kamnitimi ploščami. Na drugo tako strukturo, ki jo je sestavljalo 37 kamnov, so naleteli v bližini kamnitih skrinj v isti gomili.⁷⁷ Morda je šlo za podobne grobne parcele, zamejene s kamnitimi venci, kot so izpričane v gomilah na Hribu v Metliki ali na Budinjaku, opisane

⁷⁷ Hencken 1978, 43 s.

(figs. 13, 17, 18). Some were associated with interesting stone structures. As reported by Goldberg in connection with Tumulus VI at Preloge, 50 stones of various colours, the size of a fist or a head, were positioned in a circle in the southern part of the tumulus, while to the north and south of this were six urn graves covered by stone slabs. The second such structure was composed of 37 stones and found near the stone cists of the same tumulus.⁷⁷ These structures may represent stone rings

⁷⁷ Hencken 1978, 43 f.

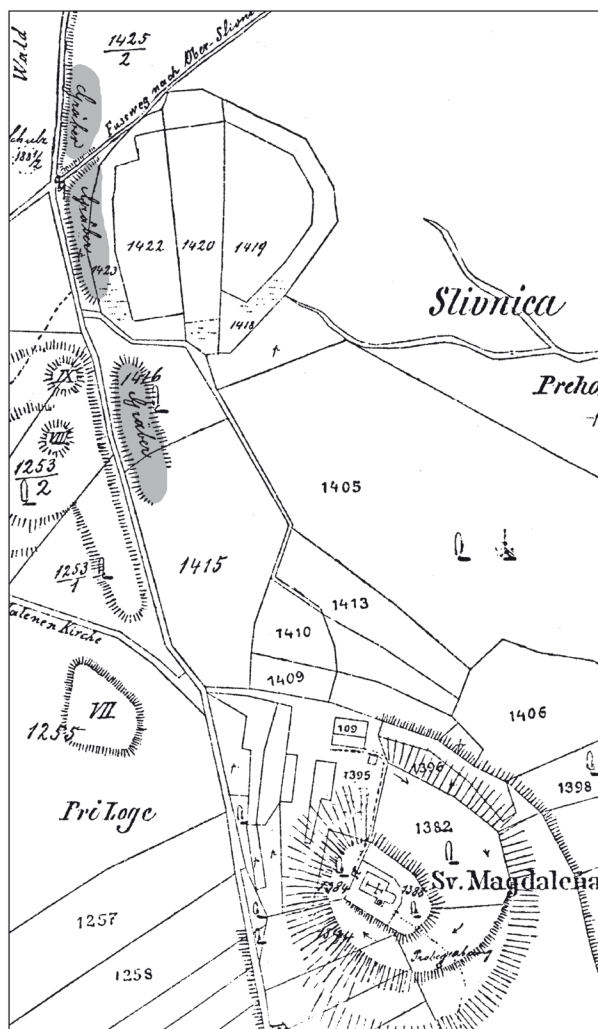
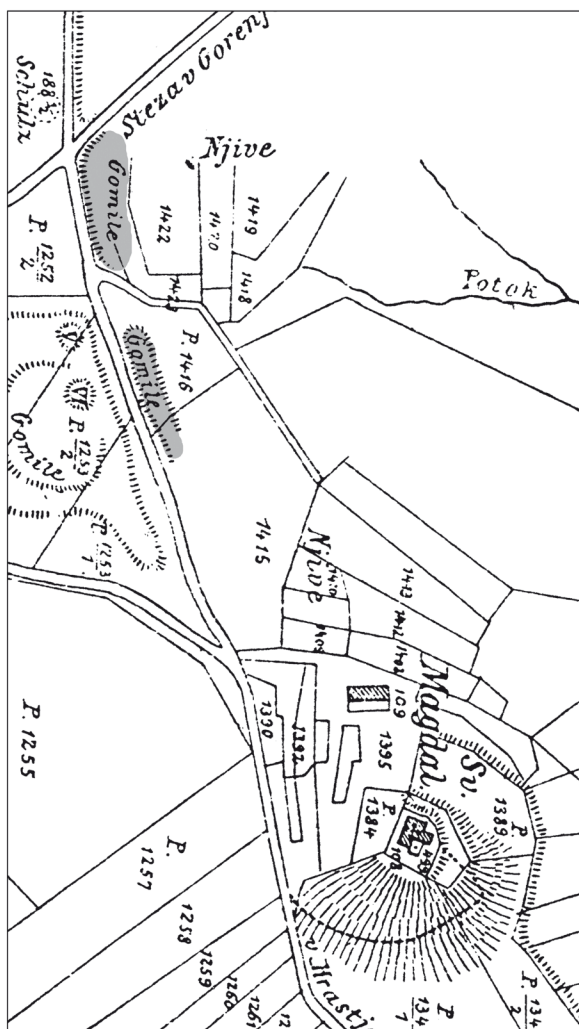

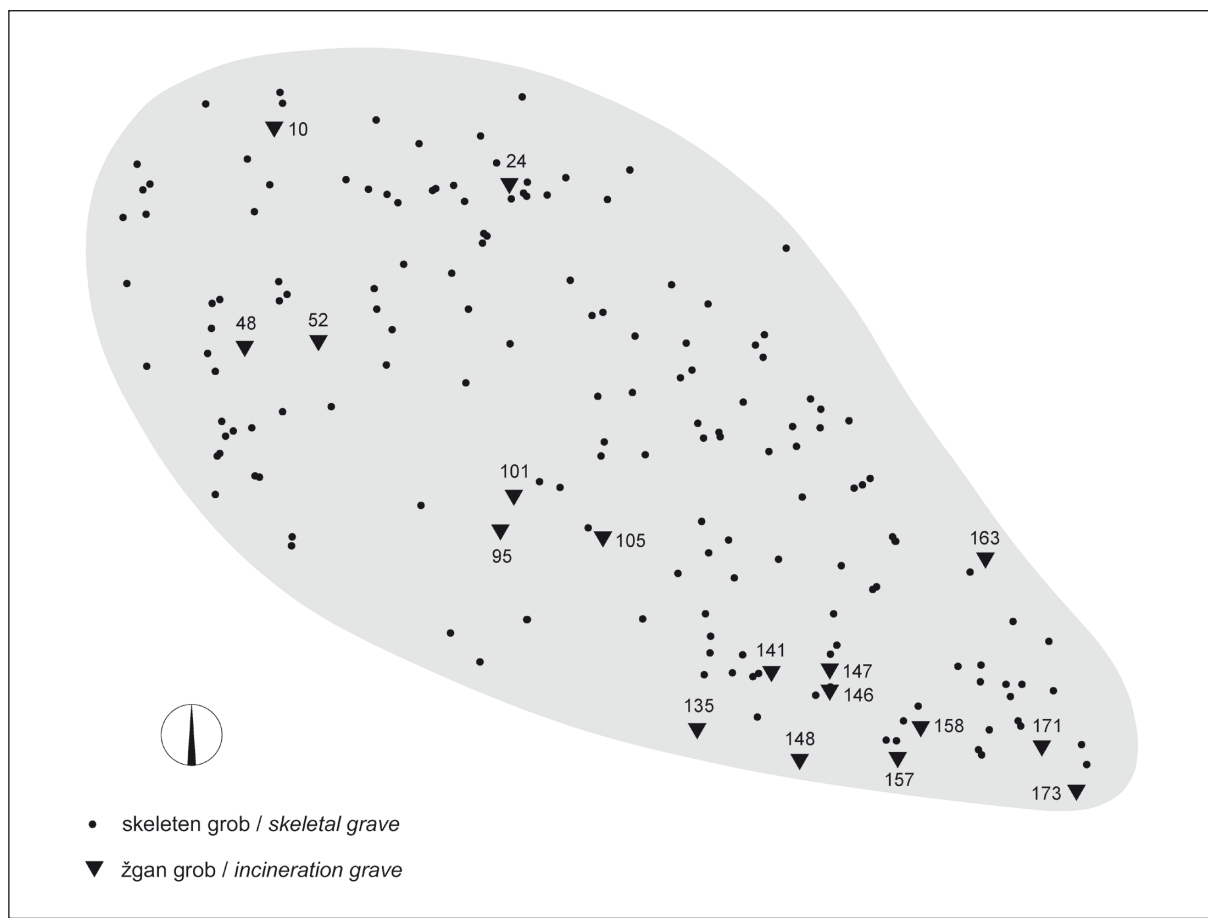

Sl. 16: Rekonstruiran tlorisni načrt gomile 13 na Prelogah po merskih podatkih v Brattinovem dnevniku (po Tecco Hvala/Dular/Kocuvan 2004, sl. 46).

Fig. 16: Ground-plan of Tumulus 13 at Preloge reconstructed on the basis of the measurements recorded in Brattina's diary (after Tecco Hvala/Dular/Kocuvan 2004, Abb. 46).

starejšem halštatskem obdobju na ta način pokopavale skupnosti, ki so živele v bližnji Ljubljani, na Molniku, na Vačah in v Mokronogu; razen tega je bil tak običaj razširjen v sosednjih pokrajinah, na katere je mejila dolenjska skupina in Magdalenska gora kot obmejni kraj.⁸⁰

Zanimivo je, da je bilo na Magdalenski gori največ žganih pokopov odkritih prav pri kopanju gomil VI, VII in 13 na Prelogah, torej v neposredni bližini zgoraj omenjenih lokacij (sl. 12–15). S fotografskega posnetka (sl. 13) je razvidno, da so nekateri grobovi v gomili VI ležali v strnjeni vrsti. Na rekonstruiranem tlorisnem načrtu gomile 13 je prav tako vidna večja skupina žganih grobov, ki so razmeščeni ob skrajnem jugovzhodnem robu razpotegnjene gomile in približno na isti globini (sl. 16).⁸¹ Ob tem velja opozoriti

⁸⁰ Puš 1971; id. 1982; id. 1984; Gabrovec 1973; id. 1987, 109; Vuga 1982, sl. 4; Dular J. 2003, 166, sl. 14 in 100; Dular/Tecco Hvala 2007, 127 ss.

⁸¹ Gr. 13/135, 13/141, 13/146, 13/147, 13/148, 13/157, 13/158, 13/171, 13/173; Tecco Hvala/Dular/Kocuvan 2004, 74 ss.

Whether the cases mentioned by Schulz, Szombathy and Rutar represent ploughed tumuli or a flat cemetery cannot be determined at this point. Having said that, cremation burials within a flat cemetery would certainly be possible, since it was a practice of the Iron Age communities at nearby Ljubljana, Molnik, Vače and Mokronog; but was also widespread in regions neighbouring the Dolenjska territory and Magdalenska gora as the frontier settlement.⁸⁰

Noteworthy in that respect is that most cremations at Magdalenska gora were found while excavating Tumuli VI, VII and 13 at Preloge, which is in the immediate vicinity of the spots mentioned above (figs. 12–15). The photo on fig. 13 shows some of the graves in Tumulus VI positioned in serried row. Moreover, the reconstructed ground-plan of Tumulus 13 reveals a group of cremation burials disposed along the south-easternmost edge of the elongated tumulus and roughly at the same depth

⁸⁰ Puš 1971; id. 1982; id. 1984; Gabrovec 1973; id. 1987, 109; Vuga 1982, fig. 4; Dular J. 2003, 166, Abb. 14 and 100; Dular/Tecco Hvala 2007, 127 ff.

na situacijo v Stični in položaj žganih grobov 100 in 101 v okviru tamkajšnje gomile 48; ležala sta zunaj najstarejše gomile in sta šele naknadno prišla pod gomilno nasutje, ko se je to postopno razširilo.⁸² Tudi na bližnjem Molniku so pod gomilo, ki je domnevno nastala v 6. ali 5. st. pr. n. št., naleteli na žgane grobove iz najmlajše žarnogrobiščne stopnje.⁸³

Na Magdalenski gori torej ne gre povsem izključiti možnosti, da so nekateri žgani pokopi pozneje prišli pod gomile. Vendar pa takšna razlaga zagotovo ne pride v poštev za tiste grobove, ki so ležali blizu sredine gomile in na različnih globinah v gomilnih nasutjih,⁸⁴ kar je nedvomno dokaz, da so bili vključeni v njeno zgradbo. Ne nazadnje so žgani grobovi zabeleženi v mnogih dolenjskih in belokranjskih gomilah,⁸⁵ čeprav so bili v manjšini, medtem ko so v severnih in severovzhodnih pokrajinah predstavljali pravilo.⁸⁶

O grobnih konstrukcijah

Med žganimi pokopi na Magdalenski gori so opazne razlike v načinu shranjevanja posmrtnih ostankov, v grobnih konstrukcijah in grobnih pridatkih. Največkrat so sežgane ostanke pokojnikov shranili v žaro, ki so jo postavili v preprosto grobno jamo in jo pokrili s kamnito ploščo (sl. 17: A); bolj redko so žganino raztresli po dnu grobne jame in nanjo položili pridatke (sl. 25), znane pa so tudi posebne kamnite grobne konstrukcije iz skrbno zloženih in pokončno postavljenih lomljencev (sl. 17: B). V nekaterih grobovih iz gomile 13 na Prelogah pa so zabeležili lesene dele konstrukcije (sl. 17: C).

Ob tem se velja vprašati, koliko so žgani pokopi na Magdalenski gori sploh stari, ali gre za domačo žarnogrobiščno tradicijo ali morda za prišleke iz drugih okolij, kjer je bil tak pogrebni ritual v navadi. V iskanju odgovora na to vprašanje si v nadaljevanju podrobneje oglejmo posamezne tipe žganih grobov in grobnih struktur ter sestav pridatkov v njih.

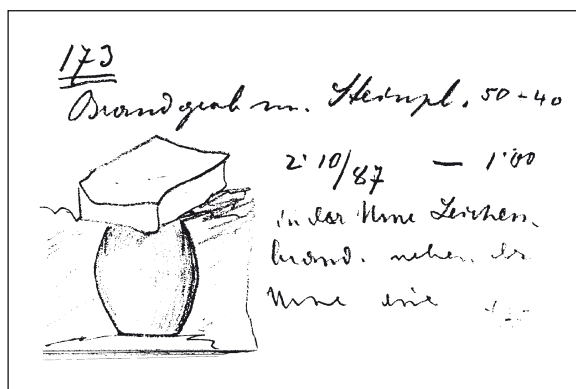

A



B

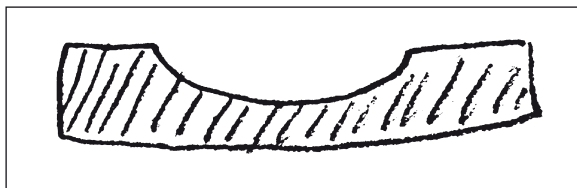

C

Sl. 17: Grobne konstrukcije žganih pokopov (po Hencknu 1978, Fig. 175; Tecco Hvala/Dular/Kocuvan 2004, sl. 30 in 40). A – Brattinova skica gr. 13/173 z žaro in pokrivno kamnito ploščo; B – Grob VI/3 s kamnito skrinjo; C – Brattinova skica lesene podloge v prerezu iz groba 13/24.

Fig. 17: Grave constructions of cremation burials (after Hencken 1978, Fig. 175; Tecco Hvala/Dular/Kocuvan 2004, Abb. 30 and 40).

A – Brattina's sketch of Gr. 13/173 with an urn and a stone slab; B – Grave VI/3 with a stone cist (middle); C – Brattina's sketch, in cross-section, of the wooden bedding from Gr. 13/24.

⁸² Gabrovec 2008, 38 ss.

⁸³ Puš 1991, 38.

⁸⁴ Laščik, gr. 12/1; Preloge, gr. VI/2, VI/3, VI/9, VI/26, 13/48, 13/52, 13/95, 13/101, 13/105: Hencken 1978, 42 ss; Tecco Hvala/Dular/Kocuvan 2004, 24, 60, 61, 67–69.

⁸⁵ Gabrovec 1999, 179 ss; Dular J. 2003, 108 s; Dular/Tecco Hvala 2007, 125 ss.

⁸⁶ Dobiat 1980; Teržan 1990a; Tomedi 2002; Gleirscher 2005; id. 2006; Vojakovič 2008; Ramšak 2009.

ŽARNI GROBOVI

Na Magdalenski gori je dokumentiranih 64 grobov z žaro v preprosti jami (*sl. 20*). Od teh jih je bilo zanesljivo 47 pokritih s kamnito ploščo, redkeje je bil grob označen še z manjšimi kamni in le v 12 primerih je bilo dno jame posuto z žganino, na kateri je stala žara. Ob žari so bile pogosto pridane ena ali več posod, ki niso vsebovale pepela in kalciniranih kosti (*sl. 18*).



Sl. 18: Žarna grobova VI/2 in VII/7 (po Hencknu 1978, Fig. 173 in 225).

Fig. 18: Cremation Graves VI/2 and VII/7 (after Hencken 1978, Figs. 173 and 225).

(*fig. 16*).⁸¹ For comparison's sake, at Stična, the cremation Graves 100 and 101 were lying within Tumulus 48 outside the earliest tumulus and only came to be covered by the earthen mound later as it grew.⁸² On nearby Molnik, the tumulus presumably made in the sixth or fifth century BC covered also cremations from the latest phase of the Urnfield Culture period.⁸³

At Magdalenska gora, the possibility of cremations coming under earthen mounds at later dates can therefore not be excluded. However, such an explanation is not plausible for the burials situated near the centre of the tumuli or at different depths within the mound,⁸⁴ which is irrefutable evidence of burials into tumuli. Cremations have been documented in numerous tumuli in Dolenjska and Bela krajina,⁸⁵ albeit in small numbers, while they represent the rule in regions to the north and north-east.⁸⁶

On grave construction

Cremations excavated at Magdalenska gora reveal differences in the manner of storing human remains, in grave construction and in grave goods. In most cases, the cremated remains were stored in an urn placed into a simple grave pit and covered with a stone slab (*fig. 17: A*). In rare cases, the remains were strewn across the bottom of the grave pit and grave goods placed on top (*fig. 25*). Also known are grave constructions made of carefully laid quarry stones set in an upright position (*fig. 17: B*). In some of the graves from Tumulus 13 at Preloge, on the other hand, wooden parts of grave construction were documented (*fig. 17: C*).

The questions that arise when discussing these examples is how old are the cremations at Magdalenska gora and do they represent the old, Urnfield culture tradition or rather foreigners that came from other milieus and retained their funerary ritual. Answers to these questions will be sought below, by taking a closer look at individual types of cremations and grave constructions as well as the grave goods in them.

⁸¹ *Gr. 13/135, 13/141, 13/146, 13/147, 13/148, 13/157, 13/158, 13/171, 13/173:* Tecco Hvala/Dular/Kocuvan 2004, 74 ff.

⁸² Gabrovec 2008, 38 ff.

⁸³ Puš 1991, 38.

⁸⁴ *Laščik, Gr. 12/1; Preloge, Gr. VI/2, VI/3, VI/9, VI/26, 13/48, 13/52, 13/95, 13/101, 13/105:* Hencken 1978, 42 ff; Tecco Hvala/Dular/Kocuvan 2004, 24, 60, 61, 67–69.

⁸⁵ Gabrovec 1999, 153 ff; Dular J. 2003, 108 f; Dular/Tecco Hvala 2007, 125 ff.

⁸⁶ Dobiati 1980; Teržan 1990a; Tomedi 2002; Gleirscher 2005; *id.* 2006; Vojakovič 2008; Ramšak 2009.

Tovrstne pokope srečamo v planih grobiščih t. i. ljubljanske skupine,⁸⁷ pa tudi v dolensko-belokranjskih gomilah, ki so bile postavljene bolj ali manj blizu planih grobišč.⁸⁸ Že samo to dejstvo kaže na proces postopne zamenjave pogrebnih ritualov in sprejemanja novih kulturnih obrazcev, ki odražajo družbeno preobrazbo teh skupnosti, živečih na prehodu iz pozne bronaste v železno dobo.

O žarah

Za žaro je bil največkrat uporabljen preprosto oblikovan pitos ali lonec, ki je bil oksidacijsko žgan, zato je običajno rdečerrjave ali temnorjave barve (sl. 17: A in sl. 19).⁸⁹ Med okrasnimi prvini so zastopana razčlenjena rebra in razne nalepke. Visoke trebušaste in vrečaste žare (sl. 19: a–c, k, l) spadajo po Dularjevi tipologiji med pitose tipa 2 in 3, ki so geografsko omejeni v glavnem na osrednjo Slovenijo in Notranjsko.⁹⁰ Na ljubljanskem planem grobišču se pojavljajo v fazi IIb in IIIa (= stopnja Podzemelj). Na bližnjem Molniku jih prav tako zasledimo v planem žarnem grobišču na Rojah, v katerem so zabeleženi tudi posamični sočasni skeletni pokopi.⁹¹ V tem času jih srečamo tudi v gomilah, kot dokazuje npr. žarni grob 6/5 iz Brezja pri Trebelnem.⁹²

Nekatere žare (sl. 19: d–g) so manjše in spadajo v vrst loncev tipa 5 po Dularju, za katere so značilna visoko pomaknjena ramena in navznoter obrnjeno ustje; praviloma so okrašeni s podkvastimi ali bradavičastimi nalepkami. Take posode so bile na Dolenskem v uporabi vse halštatsko obdobje.⁹³ Mimogrede, primerkoma

⁸⁷ Gabrovec 1983, 63 ss; Knez 1984; Teržan 1999, 137 ss.

⁸⁸ *Brezje*, VI/5: Kromer 1959a, 60, 80; Dular/Križ 1990, 537, 545; *Budinjak*: Škoberne 1999, 23 ss, sl. 6: tipi 3–5; *Dobrnica*, gr. 12/11: Parzinger 1988–1989, 560; *Libna*: Guštin 1976, 19; *Metlika*: Grahek 2004, 116 ss; *Novo mesto*: Knez 1993, 10 ss; Križ 1997, 23; id. 2000, 11 s; *Podzemelj*: Barth 1969, 16 ss; *Stična*, gr. 5/24, 48/30, 48/100, 48/101, 48/110: Gabrovec et al. 2006, 77, 83, 100, 142, 147; *Veliki Vinji vrh (Šmarjeta)-Ivanec*, gom. 1/1902, III/1879, IV/1879, VI/1879, 13/1883, 15/1883, I/1896, 2/1896, 3/1896, 4/1896, 5/1901, 6/1901, 1/1902, *Gradenjska hosta*, gom. 4/1881, 1/1901, 2/1901, 3/1901 ter *Mlada vina*, gom. 7/1879, V/1879, 3/1881, *Žaloviče-Čevnice*, gr. II/1897-1: Dular A. 1991, 25, 26, 28–30, 35–37, 40–43, 49.

⁸⁹ *Laščik*, gr. 1893/2, 8/2; *Preloge*, gr. VI/2, VI/6, VI/7, VI/13, VI/15, VI/18, VI/19, VI/28, VII/7, VII/28, VII/32, VII/45, VII/47, VIII/14, X/43, 2/3, 13/48, 13/52, 13/95, 13/146, 13/147, 13/148, 13/157, 13/158, 13/171, 13/173; *Voselca*, gr. 2/1, 2/2, 2/4. Za opise grobov glej Hencken 1978 in Tecco Hvala/Dular/Kocuvan 2004.

⁹⁰ Dular J. 1982, 19 ss, sl. 11: 4, 12: 6,7, 17 in T. 7–9; Urleb 1974, sl. 7: 1,5,6 in T. 6: 11, 10: 6, 12: 8, 14: 6, 16: 7, 26: 5.

⁹¹ Puš 1984, 148 ss, T. 1: 10, 2: 6, 3: 3, 4: 9,5.

⁹² Kromer 1959a, T. 18: 8; Dular J. 2003, 109.

⁹³ Dular J. 1982, 31, 34, T. 7: 54–57.

URN GRAVES

There were 64 graves containing an urn placed in a simple grave pit documented at Magdalenska gora (fig. 20). Of those, 47 were undoubtedly covered by stone slabs. In rare cases was the grave additionally marked with smaller stones and only in 12 graves was the bottom strewn with cremated remains on top of which stood the urn. Frequently placed beside the urn with mortal remains were one or several vessels that did not contain ashes or calcified bones (fig. 18). Such burials were found in the flat cemeteries of the so-called Ljubljana group,⁸⁷ but also in the tumuli in Dolenska and Bela krajina located more or less close to flat cemeteries.⁸⁸ The latter fact alone indicates a process of a gradual change in the funerary ritual and adoption of new norms, which reflect the social transformation of the communities living during the transition from the Late Bronze to the Iron Age.

On the urns

Most frequently serving as the urn was a simple pitthos or jar fired in an oxidizing atmosphere, usually red-brown or dark brown in colour (fig. 17: A and fig. 19).⁸⁹ The decoration on these vessels consists of ribs with impressions and various appliqués. The high belly-shaped and bag-shaped urns (fig. 19: a–c, k, l) are pitthoi of Types 2 and 3 according to Dular's typology. Spatially, they are for the most part limited to central Slovenia and Notranjska.⁹⁰ They appear on the flat cemetery at Ljubljana in phases IIb and IIIa. On nearby

⁸⁷ Gabrovec 1983, 63 ff; Knez 1984; Teržan 1999, 111 ff.

⁸⁸ *Brezje*, Gr. VI/5: Kromer 1959a, 21 f, 44; Dular/Križ 1990, 548; *Budinjak*: Škoberne 1999, 23 ff, fig. 6: Types 3–5; *Dobrnica*, Gr. 12/11: Parzinger 1988–1989, 560; *Libna*: Guštin 1976, 20 f; *Metlika*: Grahek 2004, 175 ff; *Novo mesto*: Knez 1993, 10 ff; Križ 1997, 23; id. 2000, 11 f; *Podzemelj*: Barth 1969, 16 ff; *Stična*, Gr. 5/24, 48/30, 48/100, 48/101, 48/110: Gabrovec et al. 2006, 77, 83, 100, 142, 147; *Veliki Vinji vrh (Šmarjeta)-Ivanec*, Tum. 1/1902, III/1879, IV/1879, VI/1879, 13/1883, 15/1883, I/1896, 2/1896, 3/1896, 4/1896, 5/1901, 6/1901, 1/1902, *Gradenjska hosta*, Tum. 4/1881, 1/1901, 2/1901, 3/1901 and *Mlada vina*, Tum. 7/1879, V/1879, 3/1881, *Žaloviče-Čevnice*, Gr. II/1897-1: Dular A. 1991, 25, 26, 28–30, 35–37, 40–43, 49.

⁸⁹ *Laščik*, Gr. 1893/2, 8/2; *Preloge*, Gr. VI/2, VI/6, VI/7, VI/13, VI/15, VI/18, VI/19, VI/28, VII/7, VII/28, VII/32, VII/45, VII/47, VIII/14, X/43, 2/3, 13/48, 13/52, 13/95, 13/146, 13/147, 13/148, 13/157, 13/158, 13/171, 13/173; *Voselca*, Gr. 2/1, 2/2, 2/4. For grave descriptions see Tecco Hvala/Dular/Kocuvan 2004 and also Hencken 1978, who summarized Goldberg's notes, which do not always correspond either with the existing state in the museum collection or with the published grave groups.

⁹⁰ Dular J. 1982, 173 f, Abb. 11: 4, 12: 6,7, 17 and T. 7–9; Urleb 1974, Abb. 7: 1,5,6 and T. 6: 11, 10: 6, 12: 8, 14: 6, 16: 7, 26: 5.

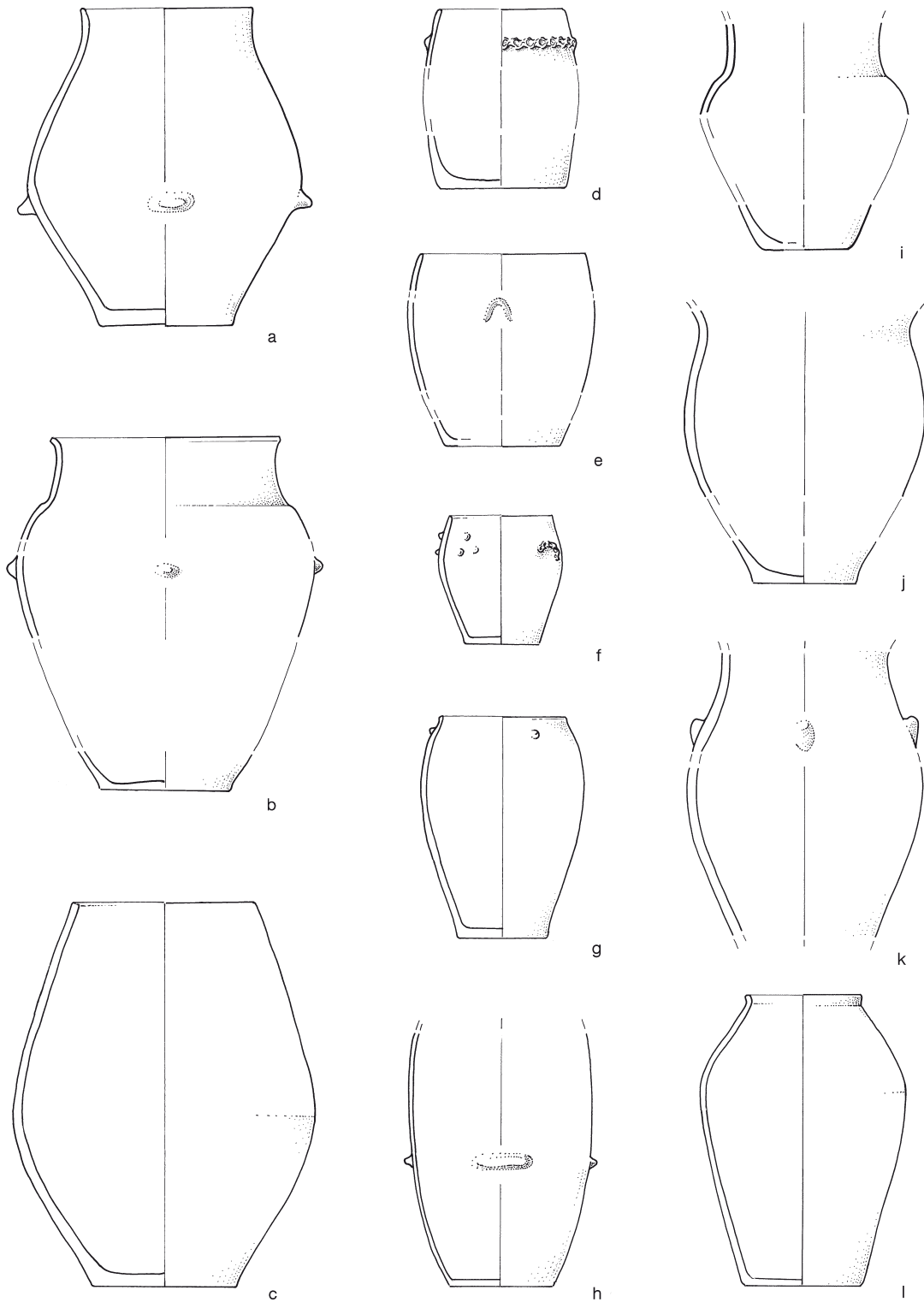

Sl. 19: Žare iz grobov na Magdalenski gori. M. = 1:10.

Fig. 19: Urns from graves at Magdalenska gora. Scale = 1:10.

a – Preloge, gr. 13/52; *b* – Preloge, gr. 13/101; *c* – Laščik, gr. 8/2; *d* – Preloge, gr. 13/173; *e* – Preloge, gr. 13/158; *f* – Preloge, gr. VI/7; *g* – Voselca, gr. 2/2; *h* – Preloge, gr. VII/7; *i* – Preloge, gr. 13/141; *j* – Preloge, gr. 13/148; *k* – Preloge, gr. 13/48; *l* – Voselca, gr. 2/1.

na sl. 19: *e* in *f* so podobne žare v istrski skupini, kjer so znane že v stopnji Istra II.⁹⁴

O spremljajočih posodah

Na Dolenjskem so v grob včasih dodali še lonec z manjšo prostornino (sl. 21: *a*). Na Magdalenski gori

⁹⁴ Gabrovec/Mihovilič 1987, 308, T. 31: 10; Mihovilič 1988, 49; ead. 2001, T. 4: 8, 5: 15, 28: 6, 38: 3, 40: 7, 41: 20.

Molnik, they were found in graves of a flat urn cemetery (at Roje), which also revealed individual contemporary inhumations.⁹¹ Furthermore, they were documented in the tumuli of the Podzemelj phase, as evidenced by urn Grave 6/5 from Brezje pri Trebelnem.⁹²

Some urns (fig. 19: *d–g*) are small and belong to jars of Type 5 after Dular, which are usually decorated with semicircular appliques or knobs. Such vessels were in

⁹¹ Puš 1984, T. 1: 10, 2: 6, 3: 3, 4: 9, 5.

⁹² Kromer 1959a, T. 18: 8; Dular J. 2003, 109.

Gom. / Gr. Tum. / Gr.	Pokrivna plošča Covered with slab	Obdan s kamni Encircled by stones	Žganina na dnu jame Ash in grave pit	Pridatki v žari Grave goods in urn	Pridatki ob žari Grave goods beside urn	Žara s pepeplom Urn with ash	Druga lončenina Other pottery	Bronasto posodje Bronze vessels	Vijčki / Spindle whorls	Fibule / Fibulae	Igle / Pins	Uhani / Earrings	Ovratnice / Neckrings	Ogrlice / Necklace	Jantar / Amber	Zapestnice / Bracelets	Nanožnica / Anklets	Pasna spona / Belt	Čelada / Helmet	Sekire / Axes	Sulice / Spears	Noži / Knives	Zatič / Toggle	Brus / Whetstone
III/14						1																		
IV/53						1																		
V 2/5						1																		
L 8/4						2																		
L 8/2						2																		1
VI/14	•					1																		
V/19	•					1																		
VII/34	•					1																		
VII/4	•					1																		
L 11/1	•			•	•	1	2																	
VI/35	•			•	•	1	1																	
13/135	•			•	•	1	1																	
VI/13	•			•	•	1																x		
VI/27	•			•	•	1				1				1		1								
13/158	•			•	•	1				1		2												
VI/20	•			•	•	1										2								
VI/11	•			•	•	1			1							2								
L 4/1	•			•	•	br				1				x	2			1						
V 2/4				•	•	1	1			1														
13/163				•	•	1	3			3				x	x	x	x							
1892/13	•			•	•	1	1+1			1						2								
VI/18	•			•	•	1	1									2								
13/148	•			•	?	1	1?																	
13/52	•			•	•	1	1													1	1			
VII/32	•			•	•	1	1			2														
VII/46	•			•	•	1	1				x	x				x	x							
13/95	•			•	•	1	1	1		2												1	1	
V 6/3	•			•	•	1	2	1																
VII/7	•			•	•	2	2?	x	3	1				2		x	x	1						
13/101	•	•		•	•	1	2	1		1	3													

Sl. 20: Struktura in lega pridatkov v žarnih grobovih v magdalenskogorskih gomilah.

lahko žarne grobove s takimi posodami časovno opredelimo na konec 7. ali v prvo polovico 6. st. pr. n. št. na podlagi kačaste fibule s sedlastim lokom⁹⁵ ter severnoitalskega tipa z dvema zankama⁹⁶ – t. i. *fibula ad arco serpeggiante a gomito*, ki so datirane v čas Este IIIA in IIIB po Peroniju.⁹⁷ Taki lončki nastopajo na Magdalenski

⁹⁵ Voselca, gr. 2/4.

⁹⁶ Preloge, gr. 13/158.

⁹⁷ Peroni et al. 1975, Fig. 38: 1, 39: 3; Eles Masi 1986, 212 ss; Teržan 1987, 19, Fig. 12.

use in Dolenjska throughout the Hallstatt period.⁹³ On that subject, related to the examples on *fig. 19: e* and *f* are urns from the Istria group that appeared already in the Istra II phase.⁹⁴

⁹³ Dular J. 1982, 177 ff, T. 7: 54-57.

⁹⁴ Gabrovec/Mihovilič 1987, 308, T. 31: 10; Mihovilič 1988, 49; *ead.* 2001, T. 4: 8, 5: 15, 28: 6, 38: 3, 40: 7, 41: 20.

Gom. / Gr. Tum. / Gr.	Pokrivna plošča Covered with slab	Obdan s kamni Encircled by stones	Žganina na dnu jame Ash in grave pit	Pridatki v žari Grave goods in urn	Pridatki ob žari Grave goods beside urn	Žara s pepeplom Urn with ash	Druga lončenina Other pottery	Bronasto posodje Bronze vessels	Vijčki / Spindle whorls	Fibule / Fibulae	Igle / Pins	Uhani / Earrings	Ovratnice / Neckrings	Ogrlice / Necklace	Jantar / Amber	Zapestnice / Bracelets	Nanožnice / Anklets	Pasna spona / Belt	Čelada / Helmet	Sekire / Axes	Sulice / Spears	Noži / Knives	Zatič / Toggle	Brus / Whetstone
V 6/1		•		•	•	1	br			3	x		2	x	x	2								
VI/25	•	•	•	•	•	1	1																	
VI/26	•	•	•			1																		
VI/15	•		•	•	?	1	2?			1			1	x										
VII/30	•		•	•	•	1	2					2				x								
13/146	•		•		•	1	1																1	
VI/36	•		•		•	1	2															1		
VI/2	•		•		•	1	1			1					x	2	14							
VII/45	•		•		•	1	1																	
VI/6	•		•		•	1	1																	
VI/7	•		•		•	1	1																	
VI/28	•		•		•	1																		
X/66			•			1																		
VI/23	•				•	2	1																	
13/171	•				•	1	1																	
13/173	•				•	1	1																	
13/157	•				•	1	1																	
L 9/gr.	•				•	1	1																	
13/141	•				•	1	1																	
13/147	•				•	1	1																	
13/48	•				•	1	1																	
VII/16	•				•	1	1				1	4		x		3								
1893/2					•	1	1					1												
1892/6					•	2	2																	
V 2/25					•	1	2																	
V 2/1					•	1	1																	
V 2/2					•	1	1																	
V 2/3					•	1	1																	
1892/10					•	1	1																	

Fig. 20: Structure and position of grave goods in the urn graves in tumuli at Magdalenska gora.

gori in drugod na Dolenjskem tudi v skeletnih grobovih.⁹⁸ Gre za zelo razširjen tip v starejši železni dobi, ki se pojavlja v različnih kulturnih okoljih. V štajerskem Kleinkleinu so bili v uporabi ves čas pokopavanja v gomilna grobišča. Dobiat je sledil njihovem oblikovnemu razvoju in pokazal, da so starejši primerki manjši in bolj konični, mlajši pa nekoliko večji in bolj sodčasti.⁹⁹ V nasebini na Pošteli na Pohorju je bil tak lonček z bradavico pod ustjem najden v plasti, ki je časovno opredeljena kot III. horizont, to je v drugo polovico 7. oz. na začetek 6. st. pr. n. št.¹⁰⁰ Na Koroškem in Gorenjskem jih srečamo v žganih grobovih v gomilah,¹⁰¹ na blejski Pristavi pa na planem grobišču v okviru ustrin oz. kulturnih prostorov, zato jim je Gabrovec pripisoval kulturni značaj.¹⁰² V svetolucijski skupini so zastopani v fazah Ib in Ic ter še kasneje; mnogokrat predstavljajo edine posode v grobu, saj tam ostankov pokojnikov praviloma niso shranjevali v žare.¹⁰³ Ob tem je zgovorno dejstvo, da jih v tolminskem grobišču ne srečamo.¹⁰⁴ V estenskih grobiščih se pojavljajo od 8. do začetka 6. st. pr. n. št.¹⁰⁵ Na Notranjskem jih zasledimo v skeletnih grobovih,¹⁰⁶ enako kot v picenski Novilari, ki je okoli leta 600 opustela.¹⁰⁷

Na Magdalenski gori so v žganih grobovih zastopani še drugi tipi spremljajočih posod (*sl. 21*);¹⁰⁸ nekateri med njimi predstavljajo novosti v oblikovnem, tehnološkem in ornamentalnem smislu (npr. redukcijsko žganje, žebliččenje, barvanje),¹⁰⁹ medtem ko so se pri žarah ohranili tradicionalna oblika, oksidacijsko žganje in plastični okras vse tja do mladohalštatskega časa.

⁹⁸ *Magdalenska gora-Preloge, gr. 13/12, 13/25, 13/61, 13/74*: Tecco Hvala/Dular/Kocuvan 2004, 55, 57, 62, 64, T. 69C: 1, 74A: 3; 87B: 6, 90F: 1; *Brezje, gr. 6/4*: Kromer 1959a, T. 46: 2 in Dular J. 2003, sl. 64.

⁹⁹ Dobiat 1980, 85 s, Abb. 13, Beil. 4.

¹⁰⁰ Teržan 1990a, 34 s, sl. 3: 13.

¹⁰¹ Vojakovič 2008, 161, Tab. 1: tip 6 in Tab. 5 ter T. 6: 1, 7: 2.

¹⁰² Gabrovec 1960a, 43, T. 13: 1.

¹⁰³ Dular J. 1982, sl. 6: 7 in sl. 10; glej še *Most na Soči, gr. 81, 92, 177, 387, 435, 855, 875, 946, 990, 1058, 1171, 1178, 1666, 1773*: Teržan/Lo Schiavo/Trampuž-Orel 1984, 2D, 11E, 18H: 2, 30G: 2, 34B: 4, 86E, 87G, 95: 2, 100E, 108F, 114G, 114J, 158F, 170C itd.

¹⁰⁴ Svöljšak/Pogačnik 2001.

¹⁰⁵ Este IIC–IIIC po Peroniju, 1975, Fig. 19: 7,8, 38: 7, 40: 4,5; Chieco Bianchi/Calzavara Capuis 1985, T. 34: 8, 44: 34, 62: 40, 64A: 12, 75: 30, 78: 7, 80: 10,11, 92: 27, 104B: 3 itd.

¹⁰⁶ Urleb 1974, T. 6: 15, 7: 8, 16: 2, 20: 11.

¹⁰⁷ Beinhauer 1985, T. 4: 48, 55, 8: 118, 10: 144,147, 12: 175, 23: 343, 24: 356, 27: 401,410, 28: 418, 31: 468, 32: 478 itd.

¹⁰⁸ *Laščik, gr. 1893/2; Preloge, gr. VI/2, VI/6, VI/7, VII/32, VIII/45, 13/173*.

¹⁰⁹ Žebličasti okras je na Dolenjskem najpogostejši v stopnji Podzemelj: glej Dular J. 1982, 89 ss. Takrat se pojavi tudi barvanje oz. grafitni okras: glej Gabrovec 2008, 47 ss. Na Magdalenski gori so z bronastimi žeblički okrašene posode zastopane v žganih grobovih 8/4, 1892/6 (?) z Laščika in VI/3 s Prelog, z barvanim oz. grafitnim okrasom pa v grobovih 1892/6, 1892/10, 12/1 z Laščika in 13/48, 13/52, 13/95, 13/163 s Prelog.

On accompanying vessels

Graves in Dolenjska sometimes revealed a jar of a small volume (*fig. 21: a*). Urn graves with such vessels at Magdalenska gora can be dated to the end of the seventh and beginning of the sixth centuries BC on the basis of serpentine fibulae with a saddle-shaped bow⁹⁵ and north Italian variants with two loops,⁹⁶ i.e. *fibula ad arco serpeggiante a gomito*, dated to phases Este IIIA and IIIB after Peroni.⁹⁷ The small jars at Magdalenska gora and elsewhere in Dolenjska appear also in inhumation burials.⁹⁸ It is, in fact, a widespread type in the Early Iron Age that appears in various contexts. At Kleinklein in Austrian Styria, they were in use throughout the time of tumulus burials. Dobiat traced their formal development and showed that early examples were small and more conical, while late were larger and more barrel-shaped.⁹⁹ The settlement at Poštela in the Pohorje Hills revealed one such jar with a knob under the rim in a layer of Horizon III, dated to the second half of the seventh or the beginning of the sixth centuries BC.¹⁰⁰ In Koroška and Gorenjska they were found in cremation burials in tumuli.¹⁰¹ The exception is the flat cemetery at Pristava in Bled where they were found within cremation places (*ustrinae*) as cult places, which led Gabrovec to ascribe them a cult character.¹⁰² In the Sveta Lucija group, they are attested to in Phases Ib and Ic and even later; whereby they represent the only vessels within graves since human remains were usually not stored in urns.¹⁰³ It is telling, however, that the cemetery at Tolmin revealed none of these jars.¹⁰⁴ In Notranjska, such jars were found in flat inhumation burials.¹⁰⁵ Outside Slovenia, they were documented in the cemeteries at Este in graves from the eighth to the beginning of the sixth centuries BC,¹⁰⁶ while they were among obligatory grave goods in inhumation burials at Novilara in Picenum, a site deserted around 600 BC.¹⁰⁷

⁹⁵ *Voselca, Gr. 2/4*.

⁹⁶ *Preloge, Gr. 13/158*.

⁹⁷ Peroni *et al.* 1975, Figs. 38: 1, 39: 3; Eles Masi 1986, 212 ff; Teržan 1987, 19, Fig. 12.

⁹⁸ *Magdalenska gora-Preloge, Gr. 13/12, 13/25, 13/61, 13/74*: Tecco Hvala/Dular/Kocuvan 2004, 55, 57, 62, 64, T. 69C: 1, 74A: 3; 87B: 6, 90F: 1; *Brezje, Gr. 6/4*: Kromer 1959a, T. 46: 2; Dular J. 2003, Abb. 64.

⁹⁹ Dobiat 1980, 85 f, Abb. 13, Beil. 4.

¹⁰⁰ Teržan 1990a, 34 f, fig. 3: 13.

¹⁰¹ Vojakovič 2008, 161, Tab. 1 (Type 6), 5 and T. 6: 1, 7: 2.

¹⁰² Gabrovec 1960a, 79, T. 13: 1.

¹⁰³ Dular J. 1982, Abb. 6: 7, 10; Teržan/Lo Schiavo/Trampuž-Orel 1984, 2D, 11E, 18H: 2, 30G: 2, 34B: 4, 86E, 87G, 95: 2, 100E, 108F, 114G, 114J, 158F, 170C etc.

¹⁰⁴ Svöljšak/Pogačnik 2001.

¹⁰⁵ Urleb 1974, T. 6: 15, 7: 8, 16: 2, 20: 11.

¹⁰⁶ Este IIC–IIIC after Peroni, 1975, Fig. 19: 7,8, 38: 7, 40: 4,5; Chieco Bianchi/Calzavara Capuis 1985, T. 34:8, 44: 34, 62: 40, 64A: 12, 75: 30, 78: 7, 80: 10,11, 92: 27, 104B: 3 etc.

¹⁰⁷ Beinhauer 1985, T. 4: 48, 55, 8: 118, 10: 144,147, 12: 175, 23: 343, 24: 356, 27: 401,410, 28: 418, 31: 468, 32: 478 etc.

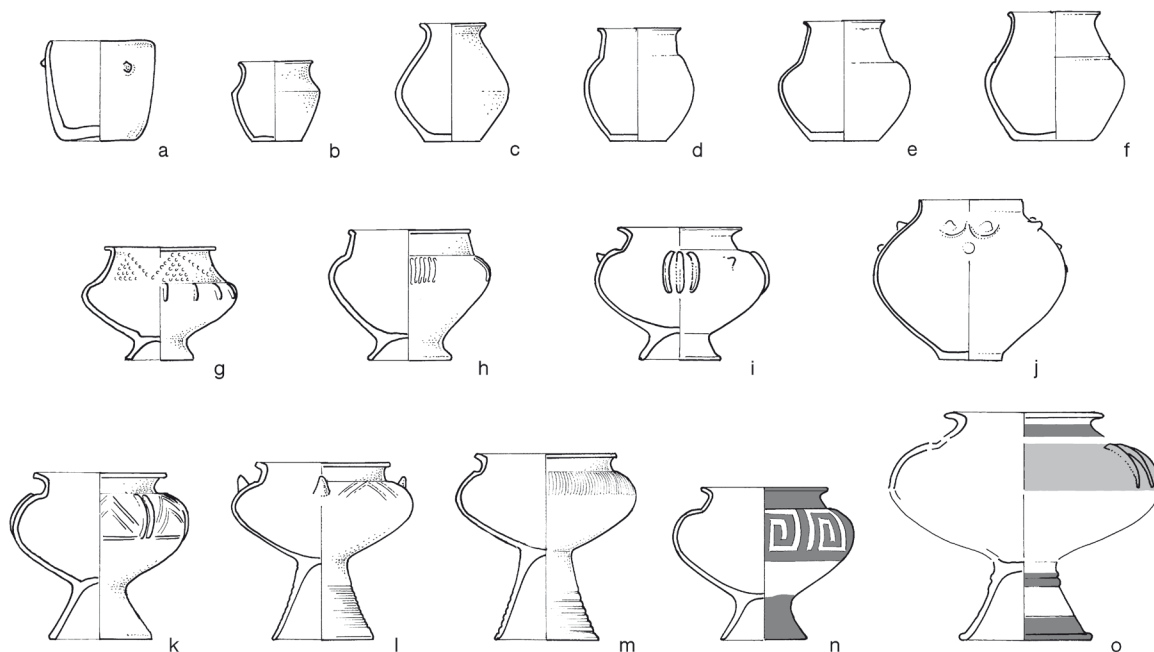

Sl. 21: Spremljajoče posode iz žarnih grobov na Magdalenski gori. M. = 1:10.

Fig. 21: Accompanying pottery from urn graves at Magdalenska gora. Scale = 1:10.

a – Voselca, gr. 2/3; b – Preloge, gr. VI/7; c – Preloge, gr. 13/171; d – Preloge, gr. VI/2; e – Preloge, gr. VI/25; f – Voselca, gr. 2/2; g – Laščik, gr. 8/4; h – Laščik, gr. 1893/2; i – Laščik, gr. 12/1; j – Preloge, gr. VII/46; k – Laščik, gr. 1892/13; l, m – Preloge, gr. 13/101; n – Voselca, gr. 6/3; o – Preloge, gr. 13/95.

Med pridanimi posodami nastopajo buče in lončki (sl. 21: c, d in f), kakršne so znane na ljubljanskem grobišču v stopnjah od IIa do IIIa.¹¹⁰ V notranjski skupini so buče časovno omejene v glavnem na fazo Notranjska IIB, medtem ko se je bikonični lonček z izvihanim ustjem (sl. 21: f) obdržal še v stopnji III.¹¹¹ V svetolucijskem krogu so bile tovrstne posode v uporabi v stopnjah od Ib do IIB;¹¹² na Gorenjskem so izpričane v času stopnje Podzemelj v žganih grobovih v gomili pri Tupaličah,¹¹³ na Štajerskem pa so zabeležene v planih žarnih grobiščih in gomilah.¹¹⁴

Geografsko so najbolj razširjeni lonci s stožčastim vratom, ki izhajajo iz žarnogrobiščne oblikovne zakladnice, kar velja zlasti za posode večjih dimenzij. Na Štajerskem se pojavljajo v grobiščih iz časa kulture žarnih grobišč in v starejšezeleznodobnih gomilah.¹¹⁵

¹¹⁰ Dular J. 1982, 106 ss, sl. 11: 3, 12: 5, 13: 12, 15, 20.

¹¹¹ Ibid., 127 ss, sl. 21: 2,3,6 in sl. 22; Gabrovec 1987, 158, sl. 9: 25, 28.

¹¹² Dular J. 1982, 92 ss, sl. 6: 6,8, 8: 26 in sl. 10.

¹¹³ Vojakovič 2008, 160, tab. 1: tip 3 in tab. 5 ter T. 1: 1, 5: 8, 6: 5.

¹¹⁴ Glej npr. plane žarne grobove iz Šentjanža pri Rečici, z Lepe ravne pod Pošteno in iz Sp. Savinskega pod Ptujsko goro ter iz gomil v Benediktu v Slovenskih goricah in Kleinkleimu: Dobiak 1980, T. 101: 6, 103: 11; Teržan 1990a, 65, 113, T. 58: 11, 59: 12, 70: 7,10, 80: 9; Črešnar 2006, 121 ss, sl. 25: L9 in L10.

¹¹⁵ Dobiak 1980, 66 ss, Abb. 8–10; Teržan 1990a, 65; Črešnar 2006, 128, sl. 25: L6 in L8.

Besides the small jars, the cremation burials at Magdalenska gora revealed other types of pottery (fig. 21);¹⁰⁸ some of them representing novelties in form, technology (reduction-fired) and decoration (bronze studs, painting).¹⁰⁹ Having said that, the urns retained the traditional form, the use of an oxidizing atmosphere when firing and appliqué decoration until the Late Hallstatt period.

Other pottery types include small jars (fig. 21: c, d and f) attested at the cemetery at Ljubljana in Phases IIa to IIIa.¹¹⁰ In the Notranjska group, the gourd-like vessels are chronologically tied mainly to the Notranjska IIB phase, while the small biconical jars with an everted rim (fig. 21: f) persisted into Phase III.¹¹¹ In the Sveta Lucija

¹⁰⁸ Laščik, Gr. 1893/2; Preloge, Gr. VI/2, VI/6, VI/7, VII/32, VII/45, 13/173.

¹⁰⁹ Decoration with bronze studs is most frequent in Dolenjska in the Podzemelj phase; see Dular J. 1982, 227 f. Painted and graphite decoration also appears in this phase: see Gabrovec 2008, 47 ff. At Magdalenska gora, pottery decorated with bronze studs was found in cremation Graves 8/4, 1892/6 (?) from Laščik and VI/3 from Preloge, while the painted or graphite decoration is discernible on the vessels from Graves 1892/6, 1892/10, 12/1 from Laščik and 13/48, 13/52, 13/95, 13/163 from Preloge.

¹¹⁰ Dular J. 1982, 205 ff, Abb. 11: 3, 12: 5, 13: 12, 15, 20.

¹¹¹ Ibid., 213 f, Abb. 21: 2,3,6, 22; Gabrovec 1987, 158, fig. 9: 25, 28.

Na Dolenjskem so primerki z manjšo prostornino, tj. tip 4 po Dularju (*sl. 21: e*), značilni predvsem za mladohalštatski čas.¹¹⁶ V svetolucijski skupnosti so jih uporabljali v stopnjah od Ib tja do IIB,¹¹⁷ znani pa so tudi v estenskem prostoru.¹¹⁸

Trebušast lonec s kratkim vratom in ozkim grlom iz žganega groba VII/46 s Prelog (*sl. 21: j*) ima najboljšo paralelo v okolici Velikega Vinjega vrha (Šmarjete), kjer je bil najden v skeletnem grobu.¹¹⁹ Uvršča se v skupino loncev tipa 2 po Dularju, ki se pojavljajo v času stopnje Stična.¹²⁰

Ciboriji (*sl. 21: g-i, k-o*) predstavljajo novo obliko, ki postane prevladujoča v mladohalštatskem obdobju.¹²¹ Mešanje starih in novih prvin je očitno v grobnih sestavih 13/95 in 13/101 s Prelog, kjer ob tradicionalnem pitosu nastopa ciborij s črno barvanimi pasovi (*sl. 21: o*) oziroma ciborija na visoki profilirani nogi (*sl. 21: l, m*). Po okrasu izstopa rdeče barvani ciborij z grafitiranim okrasom meandra (*sl. 21: n*); ta ornament ima paralele v stiškem centralnem grobu iz gomile 48 z italško konjsko opremo, ki je datiran v stopnjo Podzemelj.¹²²

O tujih keramičnih formah

V nekaterih primerih so za žare uporabljali estenske in svetolucijske tipe lončenine (*sl. 22*).¹²³ Zlasti tiste posode, ki so bile reoksidacijsko žgane in modelirane na počasnem lončarskem vretenu, so skoraj zagotovo prinesli iz zahodnih krajev, saj so se v dolenskem halštatskem okolju pojavile nenadoma v stopnji Stična, brez vzorov v starejši lokalni lončarski produkciji.¹²⁴

Na Magdalenski gori nastopajo glinaste situle (*sl. 22: b*) tako v žarnih¹²⁵ kot v skeletnih grobovih.¹²⁶ Vzhodno mejo pojavljanja takih situl predstavljajo prav dolenska halštatska središča, kjer so izdelovali tudi posnetke.¹²⁷ V ljubljanskem planem grobišču je bil najden en primerek skupaj s kačasto fibulo s sedlastim lokom.¹²⁸

group, such vessels were in use in Phases Ib to IIB.¹¹² In Gorenjska, they were found in cremation graves in the tumulus at Tupaliče, dated to the Podzemelj phase.¹¹³ In Štajerska, they were documented in flat cremation cemeteries as well as in tumuli.¹¹⁴

The most widespread form is the jar with a conical neck, which is a descendant of the Urnfield culture form, particularly the large examples. They were found in Štajerska in cemeteries from the Urnfield culture period as well as in the Early Iron Age tumuli.¹¹⁵ In Dolenjska, examples of a smaller volume were found, the so-called Type 4 after Dular (*fig. 21: e*), which are characteristic primarily of the Late Hallstatt period.¹¹⁶ The Sveta Lucija community used them in Phases Ib to IIB,¹¹⁷ while they are also known in the Este area.¹¹⁸

The belly-shaped jar with a short and narrow neck, found in Grave VII/46 at Preloge (*fig. 21: j*), has the closest parallel in a find from an inhumation burial unearthed near Veliki Vinji vrh (Šmarjeta).¹¹⁹ It belongs to Type 2 jars after Dular, which appear in the Stična phase.¹²⁰

Footed bowls (*fig. 21: g-i, k-o*) represent a new form that becomes dominant in the Late Hallstatt period.¹²¹ The coexistence of the old and the new elements is clearly discernible in Graves 13/95 and 13/101 from Preloge, where a traditional pithos was found alongside a footed bowl with black painted bands (*fig. 21: o*) or a bowl on a high moulded foot (*fig. 21: l, m*), respectively. The decoration that stands out is a graphite meander on a red-painted footed bowl (*fig. 21: n*); this decoration has a parallel in the central grave of Tumulus 48 from Stična, which contained Italic horse gear and is dated to the Podzemelj phase.¹²²

¹¹⁶ Dular J. 1982, 25, T. 5: 26-30.

¹¹⁷ *Ibid.*, sl. 6: 3 in sl. 10; Gabrovec 1987, 125, sl. 7: 30.

¹¹⁸ Peroni et al. 1975, Fig. 16: 2,10,11, 32: 9, 36: 10 itd.

¹¹⁹ *Gradenjska hosta, gom. III/1896*: Dular A. 1991, 34, T. 14: 7.

¹²⁰ Dular J. 1982, 28 s, T. 6: 42-46.

¹²¹ *Ibid.*, 44 ss, sl. 30, T. 11-18.

¹²² Gabrovec et al. 2006, T. 10 (20/21): 1; Gabrovec 2008, 47 ss; Teržan 2008, 277 s. Za okras v obliki meandra glej: Frey 1969, 72 ss, Abb. 40; Teržan 1990a, 32, 76, 119, sl. 2: 6.

¹²³ *Laščik, gr. 1892/6, 1892/10, 1892/13; Preloge, gr. VI/36, 13/105, 13/163; Voselca, gr. 6/1.*

¹²⁴ Dular J. 1982, 55 ss, 148 ss; Gabrovec 1987, 53 ss.

¹²⁵ *Laščik, gr. 1892/10, Voselca, gr. 6/1.*

¹²⁶ *Preloge, gr. 13/125, Voselca, gr. 2/6.*

¹²⁷ Kimmig 1974, 33 ss, Abb. 2; Frey 1974b, 97 ss; Dular J. 1982, 55 ss, T. 19: 163,164; Kimmig 1983, Abb. 60; Gabrovec 1987, 53 s in 59 s, sl. 3: 24, 4: 23; Parzinger 1988, Taf. 3: 10; Mihovilić 1995, 293 s, Abb. 13.

¹²⁸ Puš 1982, T. 8: 7.

¹¹² Dular J. 1982, 200 ff, Abb. 6: 6,8, 8: 26, 10.

¹¹³ Vojakovič 2008, 160, T. 1 (Type 3), 5 and T. 1: 1, 5: 8, 6: 5.

¹¹⁴ They were found at *Šentjanž near Rečica, Lepa ravna below Poštela and Spodnje Savinjsko below Ptujška gora* in flat cremation graves, while at *Benedikt v Slovenskih goricah* and *Kleinklein* they were documented in tumuli: Dobiat 1980, T. 101: 6, 103: 11; Teržan 1990a, 65, 113, T. 58: 11, 59: 12, 70: 7,10, 80: 9; Črešnar 2006, 121 ff, Abb. 25: L9 and L10.

¹¹⁵ Dobiat 1980, 66 ff, Abb. 8-10; Teržan 1990a, 65; Črešnar 2006, 128 ff, Abb. 25: L6 and L8.

¹¹⁶ Dular J. 1982, 175, T. 5: 26-30.

¹¹⁷ *Ibid.*, Abb. 6: 3, 10; Gabrovec 1987, 125, fig. 7: 30.

¹¹⁸ Peroni et al. 1975, Fig. 16: 2,10,11, 32: 9, 36: 10 etc.

¹¹⁹ *Gradenjska hosta, Tum. III/1896*: Dular A. 1991, 34, T. 14: 7.

¹²⁰ Dular J. 1982, 177, T. 6: 42-46.

¹²¹ *Ibid.*, 183 ff, fig. 30, T. 11-18.

¹²² Gabrovec et al. 2006, T. 10 (20/21): 1; Gabrovec 2008, 47 ff; Teržan 2008, 277 f. For meander decoration see also: Frey 1969, 72 ff, Abb. 40; Teržan 1990a, 32, 76, 119, fig. 2: 6.

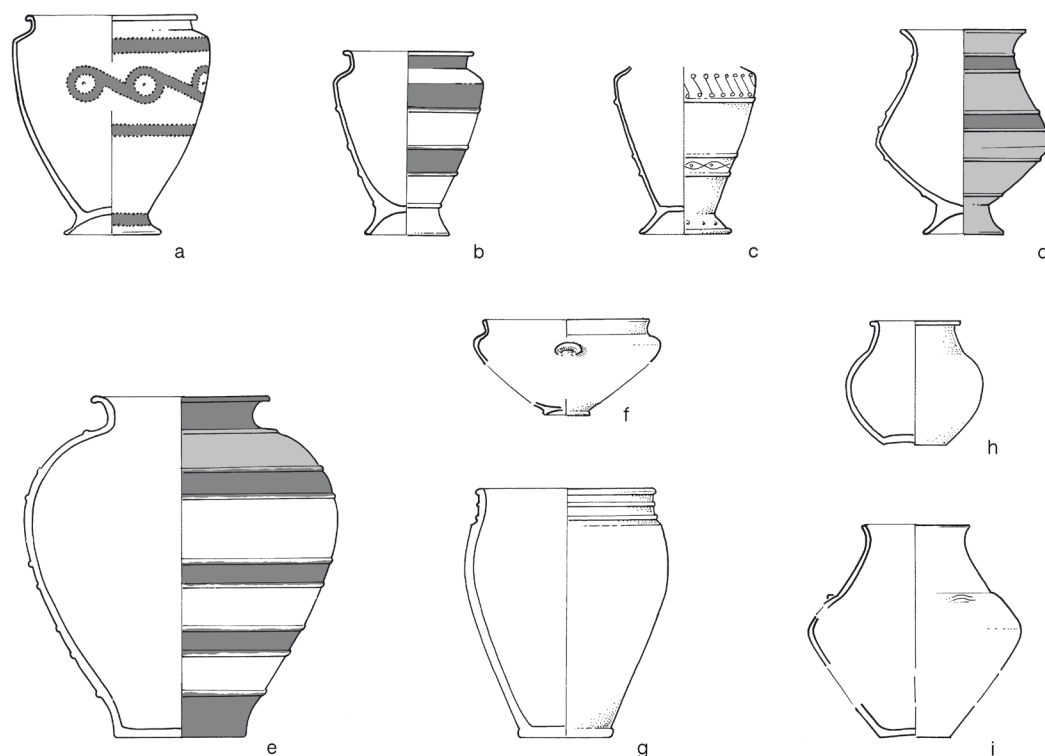

Sl. 22: Tuje forme v žarnih grobovih na Magdalenski gori. M. = 1:10.

Fig. 22: Foreign forms in the urn graves at Magdalenska gora. Scale = 1:10.

a – Laščik, gr. 1892/6; b – Laščik, gr. 1892/10; c – Preloge, gr. VI/36; d – Preloge, gr. 13/52; e, f – Preloge, gr. 13/163; g–h – Voselca, gr. 2/25.

Tovrstne posode so značilne predvsem za estensko in svetolucijsko skupnost, pogoste so v istrski skupini v stopnji IV, tj. nekako od leta 600 pr. n. št. naprej. V takajšnjem Nezakciju najdemo tudi najboljšo analogijo za primerek iz groba 1892/6 na Laščiku (sl. 22: a),¹²⁹ medtem ko bi vzporednice za okras na situli iz groba VI/36 s Prelog (sl. 22: c) lahko iskali v estenski kulturi.¹³⁰

Pojav pitosov (sl. 22: e), ki jih je Dular označil kot tip 4 in se jih drži pridevnik svetolucijski (v Posočju se pojavljajo od stopnje Sv. Lucija Ic naprej), je na vzhodu prav tako omejen s primerki z Magdalenske gore, iz Stične in z Vač in so datirani v čas stopnje Stična 2.¹³¹ Podobni so dolijem, ki so bili razširjeni ob spodnjem toku Pada in v padanski Etruriji. Na grobišču Cà Cima v Adrii nastopajo kot žare v grobovih arhajske dobe.¹³²

¹²⁹ Gabrovec/Mihovilič 1987, 312 s, T. 32: 9; Mihovilič 2001, T. 35: 5 in druge T. 8: 9-11, 9: 1, 3, 31: 1, 100: 1,2; Cestnik 2009, 28 s.

¹³⁰ Chieco Bianchi/Calzavara Capuis 1985, T. 132: 1, 231: 5, 282: 15.

¹³¹ Dular J. 1982, 21 s, sl. 6: 2 in sl. 10, T. 3: 10,11.

¹³² Chieco Bianchi/Calzavara Capuis 1985, T. 258: 1; Donati/Parrini 1999, 600 s, fig. 16.

On foreign ceramic forms

Occasionally used as urns were pottery types from Este and Sveta Lucija (fig. 22).¹²³ This is particularly true of vessels that were reoxidation-fired and thrown on a slow potter's wheel, which were almost certainly brought from these areas to the Dolenjska territory, where they appeared suddenly during the Stična phase without prototypes in the earlier local production.¹²⁴

One of these are clay situlae (fig. 22: b), which appear at Magdalenska gora in both urn¹²⁵ and inhumation graves.¹²⁶ The eastern limit of appearance for such situlae is constituted by the Hallstatt centres in Dolenjska, which even produced imitations.¹²⁷ One example is

¹²³ Laščik, Gr. 1892/6, 1892/10, 1892/13; Preloge, Gr. VI/36, 13/105, 13/163; Voselca, Gr. 6/1.

¹²⁴ Dular J. 1982, 187 f, 228 ff; Gabrovec 1987, 53 ff.

¹²⁵ Laščik, Gr. 1892/10, Voselca, Gr. 6/1.

¹²⁶ Preloge, Gr. 13/125, Voselca, Gr. 2/6.

¹²⁷ Kimmig 1974, 33 ff, Abb. 2; Frey 1974b, 97 ff; Dular J. 1982, 180 ff, T. 19: 163,164; Kimmig 1983, Abb. 60; Gabrovec 1987, 53 f, 59 f, figs. 3: 24, 4: 23; Parzinger 1988, Taf. 3: 10; Mihovilič 1995, 293 f, Abb. 13.

Tujo obliko na Dolenjskem predstavlja tudi rdeče žgana in zglajena posodica iz fine prečiščene gline (sl. 22: f), ki je bila na Magdalenski gori najdena v t. i. svetolucijskem pitosu v grobu 13/163 na Prelogah. Primerjamo jo lahko s posodico iz groba 48/15 v Stični, kjer prav tako nastopa v kombinaciji z estensko-svetolucijskimi tipi posod.¹³³

Najboljšo analogijo za žaro s profiliranim vratom (sl. 22: g) iz groba 2/25 na Voselci pa je moč najti v estenskih grobovih.¹³⁴ V Adrii so take posode uporabljali v vsakdanjem življenju, saj so menda zelo pogoste v naselbini, pa tudi v grobovih iz arhajske dobe. Gre za zelo uniformni tip lonca v zvrsti t. i. *ceramica d'impasto grezzo*, ki je bil ob koncu 7. in v prvi polovici 6. st. pr. n. št. razširjen na venetskem prostoru.¹³⁵ Različica z nogo je poznana v svetolucijski skupnosti v stopnji IIa,¹³⁶ na Magdalenski gori pa iz skeletnega groba 2/43 na Prelogah.¹³⁷ Tudi za ostali dve posodi iz groba 2/25 na Voselci (sl. 22: h, i) bi lahko našli paralele v svetolucijskih in estenskih grobiščih, čeprav ne tako ekskluzivne kot za lonca s profiliranim vratom.¹³⁸

Na svetolucijski krog se navezuje še kelihasti posodi iz grobov 13/52 in 13/24 na Prelogah (sl. 22: d), slednjemu je pripadal kaneliran trakasti uhan, ki je tipičen za svetolucijsko nošo v stopnji IIa.¹³⁹ V Stični je bila taka posoda priložena ob svetolucijskem pitosu v žganem grobu 48/30,¹⁴⁰ kar utruje prepričanje o njihovem tujem poreklu.

O bronastem posodju

Najstarejše bronasto posodje se na Dolenjskem pojavlja pretežno v žarnih grobovih in kaže na široko razpredeno mrežo stikov. V magdalenskogorskem grobu 4/1 z Laščika je bronasto vedro tipa Kurd (sl. 23: a) služilo za žaro, ki je med drugim vsebovala figuralno okrašen fragment čelade.¹⁴¹ Tudi v znamenitem stiškem grobu iz gomile 76 nastopa bronasto vedro kot žara, v njem so

known also from the flat cemetery at Ljubljana, found together with a serpentine fibula with a saddle-shaped bow.¹²⁸ These situlae were objects typical primarily for the Este and Sveta Lucija communities, while they were also common in the Istria group in its Phase IV, roughly from 600 BC onwards. The Istrian site of Nesactium offers the closest analogy for the example from Grave 1892/6 at Laščik (fig. 22: a).¹²⁹ Parallels for the decoration on the situla from Grave VI/36 at Preloge (fig. 22: c), on the other hand, could be sought in the Este culture.¹³⁰

The appearance of pithoi marked as Type 4 by Dular (fig. 22: e) and usually referred to as the Sveta Lucija pithoi (appearing in the Soča Valley from Phase Ic onwards) is also delimited to the east with the examples from Magdalenska gora, Stična and Vače, dated to the Stična 2 phase.¹³¹ They are similar to the dolia widespread along the lower Po and in Etruria Padana. At the cemetery at Cà Cima in Adria, for example, they are used as urns in graves of the Archaic period.¹³²

Another foreign form in Dolenjska is a small red-fired and burnished bowl made of refined clay (fig. 22: f) found at Magdalenska gora in Grave 13/163 at Preloge, in a so-called Sveta Lucija pithos. It has a parallel in a bowl found in Grave 48/15 from Stična, also in combination with Este-Sveta Lucija types of vessels.¹³³

The closest parallels for the urn with a moulded neck from Grave 2/25 at Voselca (fig. 22: g) can also be found in the graves at Este.¹³⁴ At Adria, on the other hand, such vessels were in every-day use, since they represent a very frequent find both in the settlement and in the graves of the Archaic period. It is a very uniform jar type of the so-called *ceramica d'impasto grezzo*, widespread in the Venetic area at the end of the seventh and first half of the sixth centuries.¹³⁵ The footed variant of this type was known to the Sveta Lucija community in its Phase IIa,¹³⁶ while at Magdalenska gora it was found in inhumation Grave 2/43 at Preloge.¹³⁷ The other two vessels from Grave 2/25 at Voselca (fig. 22: h, i) might also have parallels in the cemeteries of Sveta

¹³³ Dular J. 1982, 155 s; Gabrovec et al. 2006, T. 9: 8.

¹³⁴ Chieco Bianchi/Calzavara Capuis 1985, T. 96: 1, 107: 1, 126: 1, 145: 5, 211: 1, 231: 1,2, 236: 1,2, 250: 1, 258: 2; 278: 1; Calzavara Capuis/Chieco Bianchi 2006, T. 12: 1, 56: 1,2, 108: 1, 135: 21-23.

¹³⁵ Donati/Parrini 1999, 594 ss, fig. 14: 1.

¹³⁶ Teržan/Trampuž 1973, T. 11: 2; Chieco Bianchi/Calzavara Capuis 1985, T. 153: 1.

¹³⁷ Tecco Hvala/Dular/Kocuvan 2004, T. 39B: 3.

¹³⁸ Teržan/Lo Schiavo/Trampuž-Orel 1984, T. 30B: 2, 84D: 4, 11F: 5, 150C: 9, 160B: 9, 235F: 4; Peroni et al. 1975, Fig. 16: 11, 38: 6, 40: 1; Chieco Bianchi/Calzavara Capuis 1985, T. 9: 12, 11: 9,10, 76: 1, 197: 6.

¹³⁹ Teržan/Trampuž 1973, T. 13: 1,6,7; Teržan/Lo Schiavo/Trampuž-Orel 1984, 112G: 6; Kos 1973, 860, T. 3: 6,9, karta 1; Tecco Hvala 2007, 482.

¹⁴⁰ Gabrovec et al. 2006, T. 25: 3.

¹⁴¹ Gabrovec 1964–1965b.

¹²⁸ Puš 1982, T. 8: 7.

¹²⁹ Gabrovec/Mihovilić 1987, 312 f, T. 32: 9; Mihovilić 2001, T. 35: 5 and other examples on T. 8: 9-11, 9: 1, 3, 31: 1, 100: 1,2; Cestnik 2009, 28 f.

¹³⁰ Chieco Bianchi/Calzavara Capuis 1985, T. 132: 1, 231: 5, 282: 15.

¹³¹ Dular J. 1982, 173 f, Abb. 6: 2, 10, T. 3: 10,11.

¹³² Chieco Bianchi/Calzavara Capuis 1985, T. 258: 1; Donati/Parrini 1999, 600 f, fig. 16.

¹³³ Dular J. 1982, 234 f; Gabrovec et al. 2006, T. 9: 8.

¹³⁴ Chieco Bianchi/Calzavara Capuis 1985, T. 96: 1, 107: 1, 126: 1, 145: 5, 211: 1, 231: 1,2, 236: 1,2, 250: 1, 258: 2; 278: 1; Calzavara Capuis/Chieco Bianchi 2006, T. 12: 1, 56: 1,2, 108: 1, 135: 21-23.

¹³⁵ Donati/Parrini 1999, 594 ff, fig. 14: 1.

¹³⁶ Teržan/Trampuž 1973, T. 11: 2; Chieco Bianchi/Calzavara Capuis 1985, T. 153: 1.

¹³⁷ Tecco Hvala/Dular/Kocuvan 2004, T. 39B: 3.

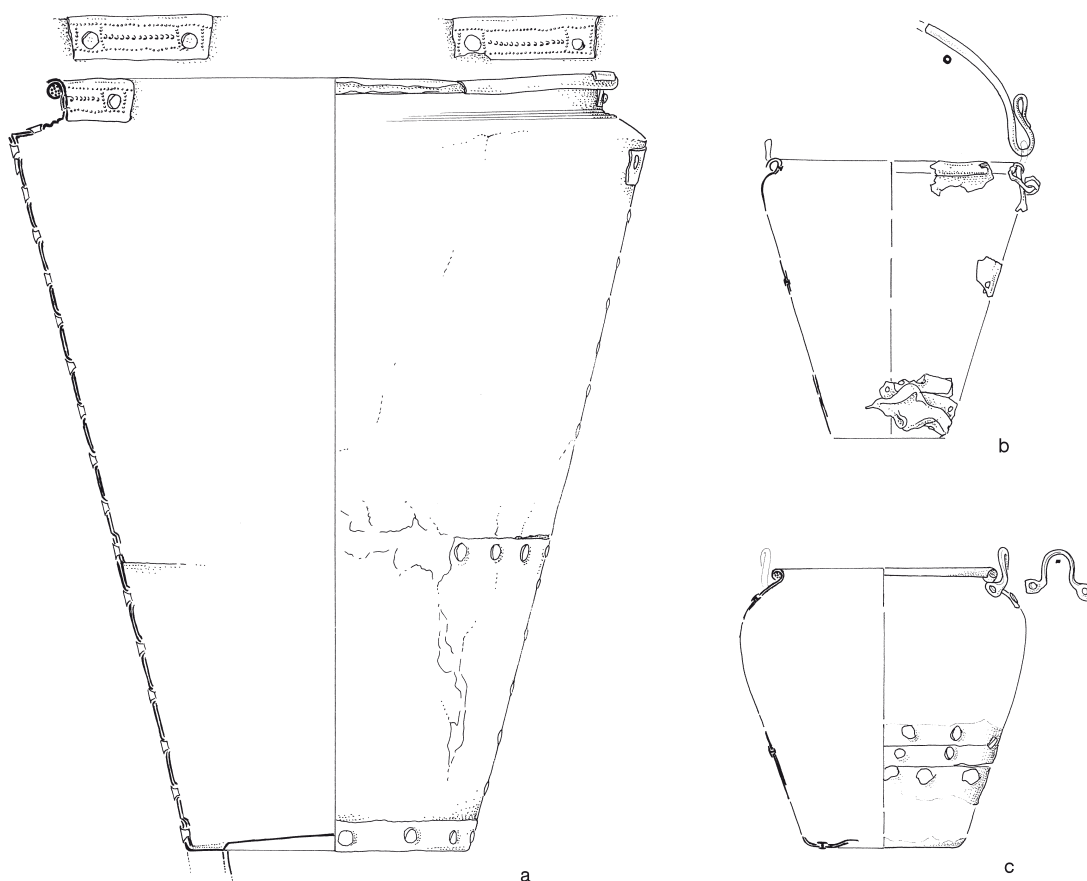

Sl. 23: Bronaste posode iz žarnih grobov na Magdalenski gori. M. = 1:5.
 Fig. 23: Bronze vessels from the urn graves at Magdalenska gora. Scale = 1:5.
 a – Laščik, gr. 4/1; b – Preloge, gr. 13/95; c – Preloge, gr. 13/101.

bile še bronasta situla s figuralno okrašenim pokrovom, lesena skodelica in grška posoda *oinochoe*.¹⁴² Bronasti žari s sežganimi kostmi in pepelom se omenjata tudi v dveh gomilah na Mladih vinih v okolici Velikega Vinjega vrha (Šmarjete).¹⁴³ Vedro je sicer žarnogrobiščna forma, ki je bila priljubljena še v halštatskem času, kar velja zlasti za eponimno najdišče Hallstatt.¹⁴⁴ Vendar pa le eno vedro iz Hallstatta v potankostih ustreza magda-

Lucija and Este, though not as select as for the jar with a moulded neck.¹³⁸

Relating to the Sveta Lucija circle are furthermore two goblet-like vessels from Graves 13/52 and 13/24 at Preloge (fig. 22: d), the latter found together with a grooved band earring typical of the Sveta Lucija costume in Phase IIa.¹³⁹ At Stična, such a vessel was found beside a Sveta Lucija pithos in cremation Grave 48/30,¹⁴⁰ which is further evidence of a foreign origin.

¹⁴² Gabrovec et al. 2006, 154 ss, T. 130–134.

¹⁴³ *Gom. 3/1879 in 1/1880*: Stare V. 1973a, T. 36: 7, 37: 1; Dular A. 1991, 40–42; Jereb 2005, 13 s.

¹⁴⁴ *Hallstatt*: Kromer 1959b, T. 1: 31, 18: 4, 23: 3, 29: 20, 39: 5,6, 40: 14, 41: 9, 42: 12, 49: 16, 51: 6, 74: 6, 79: 10, 91: 14, 92: 14, 95: 2,3, 100: 5-7, 107: 10, 109: 2, 119: 3, 114: 8, 122: 8, 126: 3, 128: 5,6, 159: 6,179: 5, 183: 6, 206: 8. Za karto razprostranjenosti glej Egg 1985a, 371 ss, Abb. 39. Halštatskim so podobni štajerski in koroški primerki, npr. *Kleinklein-Pommernkogel*: Dobiak 1980, T. A3: 1; *Breg / Frög*: Tomedi 2002, T. 14: 1, 25: 3, 88: 1, 93: 1, 104: 60.

¹³⁸ Teržan/Lo Schiavo/Trampuž-Orel 1984, T. 30B: 2, 84D: 4, 11F: 5, 150C: 9, 160B: 9, 235F: 4; Peroni et al. 1975, Figs. 16: 11, 38: 6, 40: 1; Chieco Bianchi/Calzavara Capuis 1985, T. 9: 12, 11: 9,10, 76: 1, 197: 6.

¹³⁹ Teržan/Trampuž 1973, T. 13: 1,6,7; Teržan/Lo Schiavo/Trampuž-Orel 1984, 112G: 6; Kos 1973, 862, T. 3: 6,9, Karte 1; Tecco Hvala 2007, 482.

¹⁴⁰ Gabrovec et al. 2006, T. 25: 3.

lenskogorskemu primerku iz groba 4/1 na Laščiku. Gre za grob 696, datiran v stopnjo Ha D1, ki je med drugim vseboval figuralno okrašen pokrov v orientalizirajočem slogu,¹⁴⁵ podoben onemu iz stiške gomile 76. Tipološko se dolenska vedra bolj navezujejo na svetolucijski krog. Kot je pokazala Mojca Jereb, so na Mostu na Soči zastopane vse tri različice, ki so poznane na Dolenjskem, kjer se na vsakem od treh najdišč pojavlja drugačna varianta,¹⁴⁶ kar je dodaten dokaz, da je mogoče iskati njihov izvor prav v Posočju. Tam so bila v uporabi od stopnje Ib do IIB, medtem ko sta vedri z Magdalenske gore in iz Stične datirani v stopnjo Stična, pozneje jih na tem območju ne zasledimo več.

Enako bi lahko trdili za bronaste situle brez vratu.¹⁴⁷ Na Magdalenski gori so bili koščki takih situl najdeni v pitosih iz grobov 13/95 in 13/101 na Prelogah (sl. 23: b, c). Običaj polaganja bronastih situl v žare so imeli v Posočju,¹⁴⁸ medtem ko so jih v Este in Nezakciji postavljali ob žare v kamnito skrinjo ali grobnico.¹⁴⁹ Fragmenti bronaste pločevine so izpričani še v nekaterih drugih žarnih grobovih na Magdalenski gori;¹⁵⁰ z izjemo groba VII/7 s Prelog so te grobne celote le delno rekonstruirane, vanje pa so vključeni zgolj najbolj prepoznavni predmeti. Možno bi bilo, da so jim pripadali fragmenti bronastih posod, ki so v Narodnem muzeju v Ljubljani inventarizirani med posamičnimi najdbami.¹⁵¹

Ob tem velja izpostaviti, da se prve bronaste situle na Dolenjskem pojavijo v stopnji Stična, in to precej poredkoma. Pripadale so žganim grobovom razen v primeru novomeškega groba s trinožnikom, ki je bil skeleten.¹⁵² V stopnji kačastih fibul na Dolenjskem bronastega posodja ni; v polni meri se razmahne šele v stopnji certoških fibul, ko doživi svoj vrhunec tudi v umetniškem izrazu in idejnem sporočilu. Zatorej bi težko govorili o kontinuiteti torevtične produkcije, prej bi v teh prvih izdelkih lahko videli importe ali celo lastnino prišlekov, ki so jo prinesli s seboj na Dolenjsko.

¹⁴⁵ Kromer 1959b, T. 126: 1-3; Frey 1969, 48 s, T. 55: 7.

¹⁴⁶ Jereb 2005 (diplomska naloga), 11 ss, karta 1. Avtorica pripravlja objavo v seriji Prähistorische Bronzefunde.

¹⁴⁷ Kimmig 1983, Abb. 35; Jereb 2005: varianta bronastih situl brez vratu 3A, karta 4.

¹⁴⁸ *Most na Soči, gr. 1765, 2038, 2151, 2868*: Marchesetti 1993, 173, 184 s, 189 s, 222; ter *gr. 643, 690, 698, 721, 955, 1008, 1096, 1193, 1496, 1573, 1634, 2113, 2194, 2439*: Teržan/Lo Schiavo/Trampuž-Orel 1985, 127, 136, 137, 142, 180, 188, 198, 211, 247, 259, 268, 335, 346, 382.

¹⁴⁹ *Este-Casa di Ricovero gr. 160, 217, 232, 233, 234, I*: Chieco Bianchi/Calzavara Capuis 1985, 127, 224, 267, 277, 285, 322, T. 72: 1, 143: 1, 179: 71, 185: 19, 190: 7, 217: 2; 289: 111, 113; *Nezakcij, gr. I-12, IV-1*: Mihovilič 2001, 149 ss, 174, T. 12, 17, 33: 13 itd.

¹⁵⁰ *Laščik, gr. 4/1, 12/1; Preloge, gr. VII/7; Voselca, gr. 6/3*: Hencken 1978, 52, Fig. 226a; Tecco Hvala/Dular/Kocuvan 2004, 19, 24, 89.

¹⁵¹ Tecco Hvala/Dular/Kocuvan 2004, T. 170–172.

¹⁵² Teržan 1980; Jereb 2005, 32 ss.

On bronze vessels

The earliest bronze vessels in Dolenjska were predominantly found in urn graves and reflect a widespread network of contacts. Grave 4/1 from Laščik revealed a bronze Kurd type bucket (fig. 23: a) that served as an urn and contained, among other things, a helmet fragment with figural decoration.¹⁴¹ The famous grave from Tumulus 76 at Stična also revealed a bronze bucket serving as an urn and contained a bronze situla with figural decoration on its lid, a wooden cup and a Greek *oinochoe*.¹⁴² Furthermore, two bronze urns with cremated bones and ashes are mentioned in two tumuli at Mlada vina near Veliki Vinji vrh (Šmarjeta).¹⁴³ The bucket represents an Urnfield culture form that persisted into the Hallstatt period, particularly at the eponymous site of Hallstatt.¹⁴⁴ The repertoire of this site includes only one bucket that corresponds in detail to the above-mentioned example from Grave 4/1 from Laščik. It belonged to Grave 696, dated to Ha D1,¹⁴⁵ which also contained a bronze lid with figural decoration in the Orientalizing style, similar to the above-cited lid from Tumulus 76 at Stična. Typologically, the buckets from Dolenjska are closer to those of the Sveta Lucija circle. As shown by Mojca Jereb, the buckets found at the site of Most na Soči include all three variants documented in Dolenjska, with each being found at a different site of Dolenjska.¹⁴⁶ This is further indication for their place of origin to be sought in Soča Valley, where they were in use from Phases Ib to IIB, while the buckets from Magdalenska gora and Stična are dated to the Stična phase and cannot be traced there in later times.

The same could be said of the bronze neckless situlae.¹⁴⁷ Pieces of such situlae were found at Magdalenska gora together with other grave goods in pithoi from Graves 13/95 and 13/101 at Preloge (fig. 23: b, c). The custom of laying bronze situlae into urns was practiced in Soča Valley,¹⁴⁸ while at Este and Nesactium they were

¹⁴¹ Gabrovec 1964–1965b.

¹⁴² Gabrovec *et al.* 2006, 154 ff, T. 130–134.

¹⁴³ *Tum. 3/1879 and 1/1880*: Stare V. 1973a, T. 36: 7, 37: 1; Dular A. 1991, 40 ff; Jereb 2005, 13 f.

¹⁴⁴ *Hallstatt*: Kromer 1959b, T. 1: 31, 18: 4, 23: 3, 29: 20, 39: 5, 6, 40: 14, 41: 9, 42: 12, 49: 16, 51: 6, 74: 6, 79: 10, 91: 14, 92: 14, 95: 2, 3, 100: 5–7, 107: 10, 109: 2, 119: 3, 114: 8, 122: 8, 126: 3, 128: 5, 6, 159: 6, 179: 5, 183: 6, 206: 8. For distribution map see Egg 1985a, 371 ff, Abb. 39. Similar to the Hallstatt examples are the buckets from Štajerska (Styria) and Koroška (Carinthia) regions, for example from *Kleinklein-Pommerkogel*: Dobiat 1980, T. A3: 1; Frög: Tomedi 2002, T. 14: 1, 25: 3, 88: 1, 93: 1, 104: 60.

¹⁴⁵ Kromer 1959b, T. 126: 1-3; Frey 1969, 48 s, T. 55: 7.

¹⁴⁶ Jereb 2005 (unpublished graduate thesis), 11 ff, map 1.

¹⁴⁷ Kimmig 1983, Abb. 35; Jereb 2005: Variant 3A of neckless situlae, map 4.

¹⁴⁸ *Most na Soči, Gr. 1765, 2038, 2151, 2868*: Marchesetti 1993, 173, 184 f, 189 f, 222; and also *Gr. 643, 690, 698, 721*,

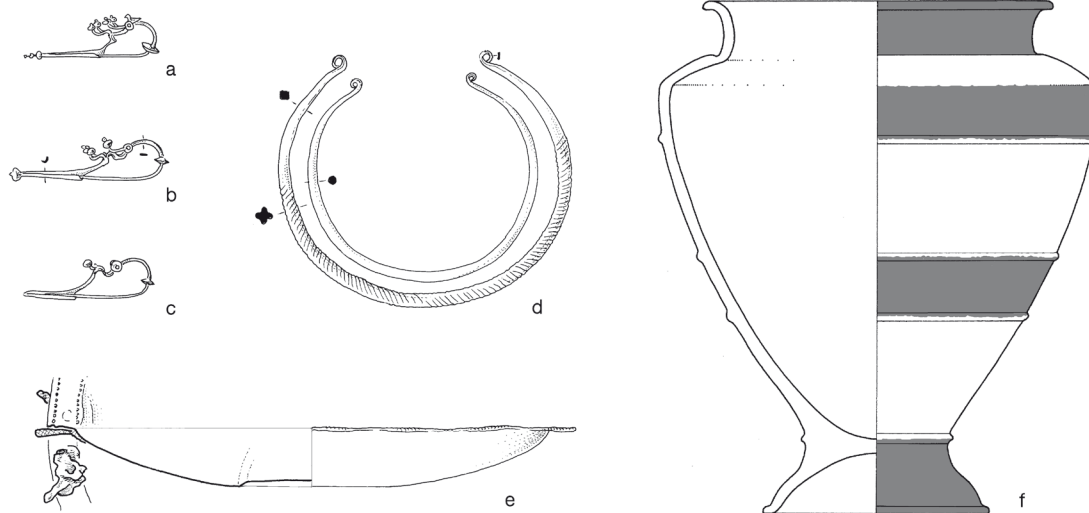

Sl. 24: Domnevna grobna celota 6/1 z Voselce. M. = 1:4.
Fig. 24: Presumable Grave group 6/1 from Voselca. Scale = 1:4.

Tej hipotezi pritrjujejo tudi trinožnik v novomeškem grobu in bronasta krožnika, ki sta bila najdena na Vačah in na Magdalenski gori. Kot poroča Dežman, so leta 1882 odkrili na jugozahodnem robu gomile 6 na Voselci žaro v obliki situle estensko-svetolucijskega tipa, ki je bila pokrita z bronastim krožnikom (sl. 24: e); v njej so bile sežgane kosti in tri kačaste fibule s pestiči ter menda dve lepi ovratnici, zapestnici in jantarna ogrlica z razdelivci, kar kaže na dekliški pokop okoli leta 600.¹⁵³ Nasprotno pa je bil na Vačah tak krožnik najden v skeletnem moškem grobu s sestavljeno čelado, o čemer je že pred desetletji pisal Gabrovec in podal karto razprostranjenosti takih krožnikov, ki za jugovzhodnoalpski prostor velja še danes.¹⁵⁴ Christopher Pare uvršča primerka z Magdalenske gore in Vač k tipu Hohmichele, ki se pojavi ob koncu 7. st. pr. n. št. v delti reke Rhône in v zgornjem toku Saône, v alpskem svetu ter Istri in v srednji Italiji.¹⁵⁵

¹⁵³ Tecco Hvala/Dular/Kocuvan 2004, 88, sl. 43, T. 143A; glej še T. 146: 18 in 147: 12,13. Najlepša fibula je izgubljena, toda na srečo obstaja risba. V to grobno celoto bi lahko spadale jantarne jagode in ploščice ter ovratnici, ki so v Narodnem muzeju v Ljubljani inventarizirane med posamičnimi najdbami; pri ovratnicah z inv. št. NMS P 2980 in 2981 je navedeno najdišče Hrastje – iz Schulzove gomile 1882/83.

¹⁵⁴ Gabrovec 1965–1966, 81 ss, karta 1; Kimmig 1983, Abb. 30; Gabrovec 1987, 46 s; Frey 1989, 295 ss; Jereb 2005, 125 s.

¹⁵⁵ Pare 1989, 442 s, Abb. 13, Liste 2.

laid alongside urns in stone cists or other stone-built tombs.¹⁴⁹ At Magdalenska gora, pieces of bronze sheet metal are mentioned in connection with several other urn graves.¹⁵⁰ With the exception of Grave VII/7 at Preloge, these are partially reconstructed grave groups that include only the most readily identifiable objects; it would thus be possible that these grave groups included fragments of bronze vessels inventoried at the National Museum of Slovenia as individual finds.¹⁵¹

In Dolenjska, the first situlae appeared in the Stična phase and very rarely at that. They were found in cremation graves with the exception of an inhumation burial with a tripod from Novo mesto.¹⁵² No situlae in Dolenjska date to the Serpentine Fibulae phase, while the Certosa phase witnessed a peak for situlae both in its artistic and iconographic expression. It would therefore be difficult to speak of a continuity of toreutic production and the early situlae more likely represent imports or even property of foreigners to Dolenjska.

This hypothesis is confirmed by the above-mentioned tripod from the Novo mesto grave as well as two

955, 1008, 1096, 1193, 1496, 1573, 1634, 2113, 2194, 2439; Teržan/Lo Schiavo/Trampuž-Orel 1985, 127, 136, 137, 142, 180, 188, 198, 211, 247, 259, 268, 335, 346, 382.

¹⁴⁹ Chieco Bianchi/Calzavara Capuis 1985, 127, 224, 267, 277, 285, 322, T. 72: 1, 143: 1, 179: 71, 185: 19, 190: 7, 217: 2; 289: 111,113; *Nesactium*, Gr. I-12, IV-1: Mihovilič 2001, 149 ff, 174, T. 12, 17, 33: 13 etc.

¹⁵⁰ Laščik, Gr. 4/1, 12/1; Preloge, Gr. VII/7; Voselca, Gr. 6/3; Hencken 1978, 52, Fig. 226a; Tecco Hvala/Dular/Kocuvan 2004, 19, 24, 89.

¹⁵¹ Tecco Hvala/Dular/Kocuvan 2004, T. 170–172.

¹⁵² Teržan 1980; Jereb 2005, 32 ff.

O drugih pridatkih

Približno 44 odstotkov žarnih grobov z Magdalenske gore je vsebovalo še razne druge pridatke. Med njimi je največ masivnega bronastega obročastega nakita in fibul, medtem ko je orožje zelo skromno zastopano (sl. 20). Čeprav bodo oprave pokojnikov podrobneje razčlenjene v posebnem poglavju, naj na tem mestu izpostavim zapestnici z vrezanim okrasom iz groba VI/20 s Prelog, ki pripadata tipu Poštela po Teržanovi; ta tip se pojavlja na prehodu iz pozne bronaste v železno dobo na jugovzhodnoalpskem prostoru od Štajerske do Notranjske.¹⁵⁶ V magdalenskogorskih žganih grobovih zasledimo tudi vozlaste fibule tipa 6a po Gabrovcu,¹⁵⁷ ki so poznane od južne Panonije in vzhodnih Alp do Posočja, vendar naj bi bile primarne na Štajerskem.¹⁵⁸ Magdalenskogorski grob 4/1 z Laščika predstavlja zanimiv kontekst, ki združuje kulturno različne prvine: figuralno okrašena sestavljena čelada je verjetno nastala v italiskem delavniškem krogu, bronasto vedro je domnevno svetolucijske provenience, medtem ko za dvozankasto vozlasto fibulo tipa 6d Teržanova meni, da ni bila izdelana v svetolucijski delavnici; podobna je štajerskim primerkom z Rifnika, Griž-Šešč in Šentjanža na eni strani, na drugi pa fibuli iz groba Benvenuti 126 v Este, kjer predstavlja tujek.¹⁵⁹

V žarnih grobovih na Magdalenski gori srečamo še nekatere druge prvine, ki se v dolenski halštatski skupnosti pojavljajo le v času stopnje Stična 2 in nimajo zveze z domačo tradicijo. To so trortasta fibula s čolničastim lokom tip Id po Ogrinovi,¹⁶⁰ nadalje kačaste fibule z valovitim lokom, s pestiči in rozetami ali koleščki, z dvema zankama oz. *fibula ad arco serpeggiante a gomito* ali pa fibule s koščeno oblogo,¹⁶¹ ki zarisujejo orbito vplivnega območja zahodnih kultur.¹⁶²

Aluzijo na estenske in svetolucijske navade lahko dobimo tudi ob grobu 13/101 s Prelog, kjer so bili pridatki v žari po besedah Brattine prekrti s črno tkanino: *“Brandgrab Steinplatte 140 cm l. 0.70 breit in 3 Theile gebrochen gegen die Mitte eingesunken an Osten liegen an der Platte große Steine. Nach Entfernung der Platte zeugt sich die eingedrückte Urne darin sichtbar mit einem schwarzen Gewebe bedeckt, eine sorgfältig zusammen geschlichtete, vom Feuer zerstörte Situla, ferner mit Knochen zu Klumpen zusammen gehackene Bronzstücke, Ohringe*

¹⁵⁶ Teržan 1990a, 64, 210, karta 1.

¹⁵⁷ Laščik, gr. 4/1; Preloge, gr. VI/15, VI/27, VII/32.

¹⁵⁸ Gabrovec 1970, 28 ss, karta IX: 6a; Teržan 1990a, 98 s, karta 10.

¹⁵⁹ Gabrovec 1964–1965b; Frey 1969, 53, Abb. 30; Egg 1980, Teržan 1990a, 98, ead. 2007a, 45, Fig. 9.

¹⁶⁰ Ogrin 1998, 107, sl. 20; Blečić 2007, 115 s, Fig. 7.

¹⁶¹ Preloge, gr. VI/2, VII/32, 13/95, 13/158, 13/163; Voselca, gr. 6/1.

¹⁶² Teržan/Trampuž 1973, 427, sl. 2: 3; Eles Masi 1986, 212 ss; Teržan 1987, 19, Fig. 12; Parzinger 1988, T. 142/1: 1,2, 142/2: 2; Teržan 1990a, 103, 149; Ettel 2007, 138 s, Fig. 3.

bronze plates from Vače and Magdalenska gora. For the latter site, Deschmann reported that an urn in the shape of an Este-Sveta Lucija type situla, covered by a bronze plate (fig. 24: e), had been found in 1882 on the south-western edge of Tumulus 6 at Voselca; the urn contained cremated bones, three serpentine fibulae with antennae, and apparently also two beautiful torques, two bracelets and an amber necklace with spacer plates, which points to a burial of a girl around 600 BC.¹⁵³ Contrariwise, such a plate at Vače was found in a male inhumation grave that further contained a composite helmet. Gabrovec wrote on this subject several decades ago, whereby he also presented the distribution map for these plates that is still valid for the south-eastern Alpine area today.¹⁵⁴ Christopher Pare defined both examples of plates as Type Hohmichele, which appeared at the end of the seventh century BC in the Rhône delta and in the upper reaches of the Saône, but also in the Alps, Istria and central Italy.¹⁵⁵

On accompanying grave goods

Roughly 44 per cent of urn graves from Magdalenska gora contained various other grave goods. The most common among these were solid bronze ring jewellery and fibulae, while weapons were very poorly represented (fig. 20). Costumes of the deceased will be treated in a special chapter, though for the purpose of the current discussion I should mention two bracelets with incised decoration from Grave VI/20 at Preloge, which belong to Type Poštela as defined by Teržan; this type appeared on the transition from the Late Bronze to the Iron Age in the south-eastern Alpine area from Štajerska to Notranjska.¹⁵⁶ The cremation graves at Magdalenska gora further revealed two-looped fibulae with a knobbed bow of Gabrovec's Type 6a,¹⁵⁷ which are known across a wide area from southern Pannonia and the eastern Alps to Soča Valley, though in the graves of Štajerska they represent a near compulsory good.¹⁵⁸ Grave 4/1 from

¹⁵³ Tecco Hvala/Dular/Kocuvan 2004, 88, Abb. 43, T. 143A; see also T. 146: 18, 147: 12,13. The most beautiful example of those fibulae is lost, but fortunately its drawing is preserved. Possibly belonging to this group are also amber beads and spacer plate, as well as a torques inventoried at the National Museum of Slovenia as individual finds. Moreover, the tumulus at Voselca near Hrastje, excavated by Schulz in 1882/83, is mentioned as the findspot of the torques with Inv. Nos. NMS P 2980 and 2981.

¹⁵⁴ Gabrovec 1965–1966, 81 ff, karte 1; Kimmig 1983, Abb. 30; Gabrovec 1987, 46 f; Frey 1989, 295 ff; Jereb 2005, 125 f.

¹⁵⁵ Pare 1989, 442 f, Abb. 13, Liste 2.

¹⁵⁶ Teržan 1990a, 64, 210, map 1.

¹⁵⁷ Laščik, Gr. 4/1; Preloge, Gr. VI/15, VI/27, VII/32.

¹⁵⁸ Gabrovec 1970, 28 ff, karta IX: 6a; Teržan 1990a, 98 f, map 10.

Gom. / Gr. Tum. / Gr.	Pokrivna plošča Covered with slab	Obdan s kamni Encircled by stones	Žganina na dnu jame Ash in the grave pit	Fibule / Fibulae	Ovratnice / Neckrings	Zapestnice / Bracelets	Lončevina / Pottery
L 1892/15	•	•	•				x
L 1892/14	•	•	•	?	?		x
P VI/16	•	•	•		1	2	1
L 1892/5			•	1?			3
P VI/24	•		•	2		x?	

Sl. 25: Grobovi z žganino na dnu jame na Magdalenski gori.
Fig. 25: Graves with ash on the grave pit bottom at Magdalenska gora.

*u Fibelstücke 2 Vasen mit hohen Füßen und Reifen an denselben liegen neben der Urne.*¹⁶³ Prekrivanje žar s tkanino je izpričano v grobovih na Mostu na Soči, v estenskem krogu pa tudi v villanovskem Verruchiu.¹⁶⁴

GROBOVI Z ŽGANINO, RAZTRESENO PO DNU JAME

Nekoliko drugačen način pokopa predstavljajo grobovi, kjer posmrtni ostanki niso bili shranjeni v žaro, temveč je bil pepel raztresen po dnu grobne jame, nanj pa položeni pridatki (sl. 25). Dva taka primera sta zabeležena v okviru izkopavanj vojvodinje Mecklenburške: v grobu VI/24 s Prelog sta bili na žganini pod kamnom odkriti dvozankasti fibuli z vozlastim lokom, ene so se držali še fragmenti železnih zapestnic; v grobu VI/16 iz iste gomile pa so bili najdeni v žganini, obkroženi s kamni, dve od ognja poškodovani majhni bronasti zapestnici, kos gladke ovratnice in še ena posoda.¹⁶⁵

Trije podobni primeri so znani s Pečnikovih kopanj na Laščiku leta 1892. O tem je poročal Rutar v prispevku za *Izvestja Muzejskega društva za Kranjsko* in v popisu predanega gradiva: "V grobu št. 5 je bilo mnogo oglja in pepela, a sredi tega železna igla za lase z bronastimi vozli, potem trije lonci, med njimi jeden cel. [...] Ravno pod gomilama razkopali smo dva žgana

Laščik revealed an interesting context with a combination of culturally different elements, namely a composite helmet with figural decoration that was probably made in an Italic workshop, a bronze bucket of a supposed Sveta Lucija provenance, while the two-looped fibula with a knobbed bow of Type 6d is believed by Teržan not to be produced in a Sveta Lucija workshop; it resembles the examples from Štajerska, namely from Rifnik, Griže-Šešče and Šentjanž, but also the fibula from Grave Benvenuti 126 at Este, where such a fibula represents a foreign object.¹⁵⁹

The urn graves at Magdalenska gora revealed several other elements that appear within the Dolenjska Hallstatt community only in the Stična 2 phase and are not related to the local tradition. These are a three-knobbed boat fibula of Type Id as defined by Ogrin,¹⁶⁰ serpentine fibulae with a wavy bow, antennae and rosettes or small wheels, with two loops, i.e. *fibulae ad arco serpeggiante a gomito*, as well as fibulae with bone or amber overlaid bow,¹⁶¹ which indicate the eastern border of influence of cultures to the west.¹⁶²

Allusions to the customs of Este and Sveta Lucija can be discerned in Grave 13/101 at Preloge, where the grave goods in the urn were covered with a black cloth as reported by Brattina: "Brandgrab Steinplatte 140 cm l. 0.70 breit in 3 Theile gebrochen gegen die Mitte eingesunken an Osten liegen an der Platte große Steine. Nach Entfernung der Platte zeugt sich die eingedrückte Urne darin sichtbar **mit einem schwarzen Gewebe bedeckt, eine sorgfältig zusammen geschichtete, vom Feuer zerstörte Situla, ferner mit Knochen zu Klumpen zusammen gehackene Bronzstücke, Ohringe u Fibelstücke 2 Vasen mit hohen Füßen und Reifen an denselben liegen neben der Urne.**"¹⁶³ Such a cover is characteristic of the Este circle and Villanovian Verucchio; it was also documented in the graves of Most na Soči.¹⁶⁴

¹⁵⁹ Gabrovec 1964–1965b; Frey 1969, 53, Abb. 30; Egg 1980, Teržan 1990a, 98, *ead.* 2007a, 45, Fig. 9.

¹⁶⁰ Ogrin 1998, 107, Abb. 20; Blečić 2007, 115 f, Fig. 7.

¹⁶¹ Preloge, Gr. VI/2, VII/32, 13/95, 13/158, 13/163; Voselca, Gr. 6/1.

¹⁶² Teržan/Trampuž 1973, 438, fig. 2: 3; Eles Masi, 1986, 212 ff; Teržan 1987, 19, Fig. 12; Parzinger 1988, T. 142/1: 1,2, 142/2: 2; Teržan 1990a, 103, 149; Ettl 2007, 138 f, Fig. 3.

¹⁶³ Tecco Hvala/Dular/Kocuvan 2004, 68 f, Abb. 35.

¹⁶⁴ Most na Soči, Gr. 2038, 2151, 2868: Marchesetti 1993, 184 f, 189 f, 222; and also Gr. 908, 1563, 1586, 1656, 2113: Teržan/Lo Schiavo/Trampuž-Orel 1985, 171, 258, 262, 271, 335; *Este-Casa di Ricovero*, Gr. 233, 234: Chieco Bianchi/Calzavara Capuis 1985, 276, 281, 283, 285; *Verucchio-La Rocca*, Gr. 13, 16–18, 27, 47, 89, 118, 119: Gentili 2003, 174, 187, 189, 191, 206, 234, 294, 343, 345, Fig. 37, 40, 42, 43, 48, 53, 57, 65.

¹⁶³ Tecco Hvala/Dular/Kocuvan 2004, 68 s, sl. 35.

¹⁶⁴ Most na Soči, gr. 2038, 2151, 2868: Marchesetti 1993, 184 s, 189 s, 222; ter gr. 908, 1563, 1586, 1656, 2113: Teržan/Lo Schiavo/Trampuž-Orel 1985, 171, 258, 262, 271, 335; *Este-Casa di Ricovero*, gr. 233, 234: Chieco Bianchi/Calzavara Capuis 1985, 276, 281, 283, 285; *Verucchio-La Rocca*, gr. 13, 16–18, 27, 47, 89, 118, 119: Gentili 2003, 174, 187, 189, 191, 206, 234, 294, 343, 345, Fig. 37, 40, 42, 43, 48, 53, 57, 65.

¹⁶⁵ Hencken 1978, 45 s, Fig. 190 in 198.

groba, obdana s kamenjem in pokrita z lepimi ploščami iz Lipljan. Pod njima so bili ostanki sežganih mrličev in precej debele črepine navadnih posod. [...] Ovratnice in bronaste igle ter mali pisker iz groba št. 14." Iz teh grobov morebiti izvirajo ovratnice in bronaste vozlaste fibule z železnim jedrom (včasih so fibulam rekli tudi igle), ki so v Narodnem muzeju inventarizirane po tipološkem principu, zato jih ne moremo z gotovostjo pripisati temu ali onemu grobu.¹⁶⁶

Ali so ti grobovi izraz ohranjanja žarnogrobiščne ga izročila? Morda. Tak način pokopa je prevladoval v Ljubljani v stopnji I, poznali sta ga tudi dobovska žarnogrobiščna skupnost ob Savi in tolminska ob Soči,¹⁶⁷ medtem ko je bil v starejši železni dobi običajen predvsem v svetolucijski skupnosti.¹⁶⁸

Vsekakor so znak ljubljansko-dolenjske kulturne identitete dvozankaste vozlaste fibule tipa 5a po Gabrovcu. Na ta tip t. i. vaških fibul le redko naletimo izven teritorija med rekama Savo in Kolpo, kjer se pojavlja v stopnjah Ljubljana IIB in IIIa.¹⁶⁹

ŽGANI POKOPI V KAMNITIH SKRINJAH

Ko je Pečnik jeseni 1892 zakopal v gomili na skrajnem severnem koncu grobišča na Laščiku, sprva ni razen pepela našel ničesar, vendar ni odnehal in se ju je vnovič lotil naslednjo pomlad, ko je v vsaki odkril po en žarni grob. Po njegovih besedah so iz gomile 11 izvlekli izpod skrilaste plošče 70 cm visoko in 56 cm široko žaro, ki je vsebovala sežgane kosti, ter skledo in črn dvoročajni lonc (predmetov v muzejski zbirki ni mogoče identificirati). Večje odkritje ga je čakalo v sosednji gomili 12. O grobu, ki ga je izkopal (Laščik, gr. 12/1), sta ohranjeni dve njegovi poročili, ki v popisu pridatkov nista povsem skladni; objavil pa je tudi fotografijo (sl. 26).¹⁷⁰ Na osnovi teh dokumentov smo prepoznali posodo, železno sekuro z dvostranskimi plavutmi in dereze, ki jih je opisal kot "dvoje zakrivljenih želez z robovi na spodnji strani". Žare in posode z barvanimi pasovi¹⁷¹ ter sulic(e) in noža oz. "krivača" med preostalimi predmeti ni mogoče zanesljivo določiti, prav tako ne koščkov domnevno bronaste posode.

¹⁶⁶ Tecco Hvala/Dular/Kocuvan 2004, 22 s, T. 147: 9-13, 148: 7,8, 152: 1-3.

¹⁶⁷ Gabrovec 1973, 342, razpredelnica 1; Puš 1973, sl. 2; Svovljšak 1973, T. 1 in 2; Stare F. 1975, T. 63-65.

¹⁶⁸ Teržan/Trampuž 1973, 418 s.

¹⁶⁹ Gabrovec 1970, 27, karta 8c; Teržan 1990a, 63; ead. 2009a, 206, Abb. 14: 7, 15.

¹⁷⁰ Tecco Hvala/Dular/Kocuvan 2004, 24, sl. 19.

¹⁷¹ Med posodami v tipološko urejeni prazgodovinski zbirki Narodnega muzeja v Ljubljani so tri situle estensko-svetolucijskega tipa, fragmenti lonca s stožčastim vratom in dva ciborija z barvanim okrasom: Tecco Hvala/Dular/Kocuvan 2004, T. 173: 1-3,6-8.

CREMATED REMAINS IN GRAVE PIT

A slightly different burial rite is that observed in graves where cremated remains were not stored in an urn, but rather strewn across the bottom of the grave and the goods placed on top (fig. 25). Two such graves were reportedly found during the excavations by the Duchess of Mecklenburg. The first is Grave VI/24 at Preloge that contained, underneath a stone slab, cremated remains with a pair of two-looped fibulae with a knobbed bow placed on top, whereby one had fragments of iron bracelets attached to it. The second is Grave VI/16, from the same tumulus, where the cremated remains were surrounded by stones and topped by two small bronze bracelets damaged by fire, a piece of torque and a ceramic vessel.¹⁶⁵

Three similar examples are known from Pečnik's investigations at Laščik in 1892. As seen from Rutar's reports in *Izvestja Muzejskega društva za Kranjsko* and the list of the material delivered to the museum in Ljubljana, Grave no. 5 contained a lot of charcoal and ashes, in the midst of which were an iron hairpin with bronze knots and three jars, one of them complete. He further writes that two cremation graves were found under the tumuli, surrounded by stones and covered by beautiful stone slabs from Lipljane; under these were cremated human remains and simple pots with rather thick walls. He mentions torques, bronze pins (word sometimes used for fibulae) and a small jar in Grave no. 14. These finds could be identified in the torques and bronze knobbed fibulae with an iron core inventoried at the National Museum of Slovenia according to their typology rather than grave provenance.¹⁶⁶

Can these graves be interpreted as a persistence of the Urnfield culture tradition? Possibly. This burial rite was dominant at Ljubljana in Phase I, it was also practiced by the Dobova Urnfield culture community along the Sava and by the Tolmin community along the Soča,¹⁶⁷ while during the Early Iron Age it was common primarily within the Sveta Lucija community.¹⁶⁸

A clear mark of the Ljubljana-Dolenjska cultural identity was certainly the two-looped fibulae with a knobbed bow of Type 5a after Gabrovec. This type of the so-called Vače fibulae is only rarely encountered outside the territory delimited by the rivers Sava and Kolpa, where it appears in Phases IIB and IIIa.¹⁶⁹

¹⁶⁵ Hencken 1978, 45 f, Figs. 190, 198.

¹⁶⁶ Tecco Hvala/Dular/Kocuvan 2004, 121 f, T. 147: 9-13, 148: 7,8, 152: 1-3.

¹⁶⁷ Gabrovec 1973, 368 ff, Tab. 1; Puš 1973, fig. 2; Svovljšak 1973, T. 1, 2; Stare F. 1975, T. 63-65.

¹⁶⁸ Teržan/Trampuž 1973, 438 f.

¹⁶⁹ Gabrovec 1970, 27, karta 8c; Teržan 1990a, 63; ead. 2009a, 206, Abb. 14: 7, 15.



Sl. 26: Grob 12/1 na Laščiku (foto: F. Lampe).

Fig. 26: Grave 12/1 at Laščik (photo: Lampe).

Drugi trije pokopi v kamnite skrinje so bili odkriti pri kopanju gomile VI na Prelogah. Goldberg je opisal njihovo lego v gomili in približne stratigrafske odnose. Grob VI/3 je menda ležal blizu sredine gomile in 80 cm pod žarnim grobom 2. Dve veliki kamniti plošči sta prekrivali 60 cm dolgo, 35 cm široko in 50 cm visoko kamnito skrinjo, ki je bila napolnjena z zemljo in pepelom (sl. 17: B in sl. 28). V njej sta bili dve slabo ohranjeni

CREMATION BURIALS IN STONE CISTS

When opening two tumuli on the northernmost edge of the Laščik cemetery in autumn of 1892, Pečnik at first found nothing except ashes. He persisted, however, and found one urn grave in each next spring. He writes that a 70cm high and 56cm wide urn was pulled from under a slate slab in Tumulus 11, containing cremated bones, a bowl and a black two-handled jar (these objects could not be identified in the museum collection). A bigger discovery awaited in adjacent Tumulus 12. The grave he dug there (Laščik, Gr. 12/1) is featured in two of his reports, which differ in the list of finds, and include a photo of the grave (fig. 26).¹⁷⁰ This allowed a vessel, iron winged axe and crampons to be identified. Apart from these, the report mentions an urn and a vessel with painted decoration¹⁷¹ as well as one or more spearheads and a knife; these, however, could not be identified among the objects in the Ljubljana museum; the same goes for the pieces of a supposed bronze vessel.

The other three burials in stone cists were found in Tumulus VI at Preloge. Goldberg described their position within the tumulus and approximate stratigraphic relations. Grave VI/3 was reportedly situated near the centre of the tumulus, 80cm under urn Grave 2. Two large stone slabs covered a 60cm long, 35cm wide and 50cm deep cist filled with earth and ashes (fig. 17: B and fig. 28). It contained two poorly preserved vessels, one decorated

¹⁷⁰ Tecco Hvala/Dular/Kocuvan 2004, 24, sl. 19.¹⁷¹ The museum in Ljubljana keeps three situlae of the Este-Sveta Lucija type, fragments of a jar with a conical neck and of two footed bowls with painted decoration without preserved contexts. See Tecco Hvala/Dular/Kocuvan 2004, T. 173: 1-3,6-8.

Gom. / Gr. Tum. / Gr.	Pokrivna plošča Covered with slab	Kamnita skrinja Stone cist	Lesena podloga Wooden bedding	Žara s pepelom Urn with ash	Druga lončenina Other pottery	Glinaste kroglice / Clay beads	Fragment bronaste pločevine Fragment of bronze sheet	Uhani / Earrings	Iglice / Pins	Gumb / Knob	Pasna spona / Belt	Čelada / Helmet	Sekire / Axes	Sulice / Spears	Bodalo / Dagger	Noži / Knives	Brus / Whetstone	Dereze / Crampons	
P VI/9	•	•			2														
P VI/3	•	•			2				1	1								1	
L 12/1	•	•		1	2		x					?	1	1-2		1			2
P VI/10	•	•		1															
P 13/105			•	1	1	5													
P 13/24			•		1			1											
P 13/10			•		3						1			2	1	1	1		

Sl. 27: Žgani grobovi s kamnitimi skrinjami ali lesenimi ostanki.

Fig. 27: Cremation graves with stone cists or wooden remains.



Sl. 28: Kamnita skrinja v grobu VI/3 z izkopavanj vojvodinje Mecklenburške (po Bonfante 1981, Fig. 1).
Fig. 28: Stone cist of Grave VI/3 excavated by the Duchess of Mecklenburg (after Bonfante 1981, Fig. 1).

posodi, ena z žebličastim okrasom, druga “navadna” (!).¹⁷² Zraven skrinje so tik pod pokrivno ploščo ležali dolga večglava igla s stožčastim zaključkom, bronast gumb in brus. Druga kamnita skrinja VI/9 podobnih dimenzij (70 x 55 x 35 cm) je bila odkrita na globini 2,1 m. Pokrita je bila s kamnito ploščo in zapolnjena s črno prežgano zemljo, pepelom in sežganimi kostmi, v njej so ležale črepinje rdeče posode z nogo ter rdečega pokrova ali sklede, ki zaradi fragmentarnosti niso objavljene; Hencken je pripomnil, da dozdevno ne pripadajo estenskemu tipu posod. V razdalji 1,4 m od groba VI/9 in 1,1 m globoko v gomili je stala še tretja kamnita skrinja (VI/10), ki je merila 80 x 70 x 45 cm. Vsebovala je slabo ohranjeno žaro, okrašeno z bradavicami in vrezanim cikcak ornamentom, obrobjenim z vrsto vtisnjenih pik.¹⁷³

Razširjenost žganih pokopov v kamnitih skrinjah

Taki pokopi so v dolensko-belokranjskih gomilah bolj redek pojav. Omenjajo se v treh gomilah iz okolice Velikega Vinjega vrha (Šmarjete). V eni je Pečnik leta

¹⁷² V objavljeni grobni celoti (Hencken 1978, 42, Fig. 176) nastopa poleg fragmenta posode z žebličastim okrasom še estenska situla s črno barvanim okrasom, kar ne ustreza Goldbergovi omembi navadne posode, zato je njena pripadnost temu grobu vprašljiva. Teržanova na osnovi te situle popravlja datacijo groba in ga postavlja v mlajšo stopnjo (Teržan 2008, 212, op. 79).

¹⁷³ Hencken 1978, 43 s.

with bronze studs and the other “ordinary” (!).¹⁷² Beside the cist and just beneath the stone slab, a long multi-knobbed pin, a bronze perforated knob and a whetstone were found. The second cist, Grave VI/9, was similar in size (70 x 55 x 35cm) and was found at a depth of 2.1m. It was covered by a stone slab and filled with black burnt earth, ashes and cremated bones and contained shards of a red footed vessel and of a red lid or bowl, which are not published due to their poor state of preservation; in connection with these Hencken added that they presumably did not belong to Este vessel types. At a distance of 1.4m from Grave VI/9 and at a depth of 1.1m the third cist was found (VI/10), which measured 80 x 70 x 45cm. It contained a poorly preserved urn, decorated with knobs and zigzag grooves lined with impressed dots.¹⁷³

Distribution of cremation burials in stone cists

Such burials are a rather rare find in the tumuli of Dolenjska and Bela krajina. They were reportedly found in three tumuli near Veliki Vinji Vrh (Šmarjeta).

¹⁷² The grave group published by Hencken (1978, 42, Fig. 176) contains, apart from the fragment of a vessel decorated with bronze studs, also a situla of the Este type with black painted bands, whereby the latter does not correspond to Goldberg's mention of ordinary pottery, its grave provenance thus being questionable. However, Teržan used this situla as basis for dating the grave in a later phase than we do (Teržan 2008, 213, n. 79).

¹⁷³ Hencken 1978, 43 f.

1896 odkril štiri žgane grobove,¹⁷⁴ trije so vsebovali kamnito skrinjo z enakim inventarjem (žara s sežganimi kostmi, pokrita s skledo in še en ciborij). Tudi v drugih dveh gomilah na isti ledini sta pokopa v kamnito skrinjo vsebovala tridelno garnituro posod (žara, lonec, skleda). Med pridatki v žari iz gomile V/1896 se omenjajo še sežgani bronasti zapestnici, prstan, vijček idr.,¹⁷⁵ medtem ko so v žari iz gomile 7/1901 po Pečnikovem poročilu našli "eine Broncelandze, ein Kelt flach, eine gebrochene Eisenlanze, ein Griff von einem Dolch aus Eisen und mehrere Broncenegel". Slednjih predmetov razen ročaja *mahaire* v zbirki Narodnega muzeja ni bilo mogoče z zanesljivostjo identificirati,¹⁷⁶ kljub temu pa lahko domnevamo, da gre za grob iz najstarejše faze pokopavanja v gomile.

O pokopu v kamnito skrinjo poroča Pečnik tudi na Brezju pri Trebelnem; šlo naj bi za plani grob v bližini gomile I, vendar se je z objavo primarnega vira in ovrednotenjem terenske situacije izkazalo, da gre pravzaprav za grob v gomili 14 in ne zunaj nje. Vseboval je bikonično žaro z izvihanim ustjem, dvoročajni lonček, latvico, skodelico s presegačim ročajem, železni obročast nakit, dvoankasto fibulo tipa 1a po Gabrovcu, po čemer ga je moč datirati v stopnjo Podzemelj 1.¹⁷⁷

Žgani pokopi v kamnite skrinje so zabeleženi še v Podzemlju.¹⁷⁸ V največji gomili na vzhodnem obrobju gomilnega grobišča je bil odkrit žgani grob, obložen s kamnitimi ploščami, v katerem so bile lepo okrašene posode, igli in sulična ost. Dular je med tipološko inventariziranimi najdbami identificiral bogato ornamentirane lonce s stožčastim vratom, kakršni se pojavljajo v časovni stopnji Podzemelj. Tri kamnite skrinje, drugo vrh druge, so menda našli tudi v eni izmed gomil za vasjo Grm. V najnižji, ki je merila 100 x 50 cm, je bila žara s pepelom in bronastim križcem, med črepinjami posod, raztresenimi okoli nje, pa je bil zapičen antenski meč, ki je označevalec stopnje Podzemelj 1.¹⁷⁹ S tem je seznam žganih pokopov v kamnite skrinje na teritoriju dolenjske halštatske skupnosti bolj ali manj izčrpan. Morda lahko k njim priključimo še primer z Budinjaka v Gorjancih, kjer so med drugim odprli gomilo v sredini nekropole, ki je vsebovala en sam žarni grob. Pod pokrivno kamnito ploščo je stal pokonci postavljen lomljenec, ki je dozdevno predstavljal eno stranico kamnite skrinje,

¹⁷⁴ *Gradenjska hosta, gom. 1-1896/gr. 1-4*: Dular A. 1991, 35, T. 15: 1-4, 16, 17: 1,2.

¹⁷⁵ *Gradenjska hosta, gom. V/1896*: *ibid.*, 35, T. 15: 5-15.

¹⁷⁶ *Gradenjska hosta, gom. 7/1901*: *ibid.*, 36 s. Ročaj *mahaire* je objavila V. Stare 1973a, T. 6: 12, za njo pa Frey 1980a, Abb. 2.

¹⁷⁷ Kromer 1959a, 58, T. 14; glej še Dular/Križ 1990, 543 ss in Dular J. 2003, sl. 59 A. Za fibulo glej Gabrovec 1970, 11, karta IV.

¹⁷⁸ Dular J. 1978, 11, sl. 3, T. 34; *id.* 1979, 76 ss; *id.* 1982, 23 ss, T. 4: 17.

¹⁷⁹ Gabrovec 1964-1965a, 32, T. 1; Dular J. 1978, 9, 11, T. 35: 1-3; *id.* 2003, 108 ss, sl. 58A.

In one tumulus, Pečnik unearthed four cremation burials in 1896,¹⁷⁴ three of which had a stone cist with the same contents (urn with cremated remains covered by a bowl, and a footed bowl). The cist burials in the other two tumuli on the same fallow contained a three-piece set of vessels (urn, jar, bowl). Furthermore, the goods found in an urn in a grave in Tumulus V/1896 included two burnt bronze bracelets, a finger-ring, a spindle whorl and other items,¹⁷⁵ while for the urn in Tumulus 7/1901 Pečnik reported on "eine Broncelandze, ein Kelt flach, eine gebrochene Eisenlanze, ein Griff von einem Dolch aus Eisen und mehrere Broncenegel". With the exception of a *machaira* hilt, none of these objects could be identified in the collection of the National Museum of Slovenia,¹⁷⁶ in spite of which it can be supposed that the grave dates to the earliest phase of tumulus burials.

Pečnik also reported on a stone cist burial at Brezje pri Trebelnem; supposedly in a flat grave in the vicinity of Tumulus I. However, the publication of the primary source and the evaluation of the field situation showed that it is really a burial in Tumulus 14. The grave contained a biconical urn with an everted rim, a small two-handled jar, a bowl, a cup with a high handle, iron ring jewellery, two-looped fibula of Type 1a after Gabrovec, all of which dates the grave into the Podzemelj 1 phase.¹⁷⁷

Cist burials were also documented at Podzemelj.¹⁷⁸ The largest of the tumuli on the eastern fringes of its tumulus cemetery revealed a cremation burial in a stone cist, and in it beautifully decorated vessels, two pins and a spearhead. In connection with that, Dular was able to identify, among the typologically inventoried finds, richly decorated jars with a conical neck, such as appear in the Podzemelj phase. Further three cists, reportedly one on top of the other, were found in one of the tumuli near the village of Grm. The lowest, measuring 100 x 50cm, contained an urn with ashes and a small bronze cruciform button, while stuck among the shards around the urn was an antenna sword, which marks the Podzemelj 1 phase.¹⁷⁹ The list of cist burials on the territory of the Dolenjska community is thus exhausted, with a possible addition of the Croatian site of Budinjak in the Gorjanci Hills. At the latter, a tumulus in the centre of the cemetery revealed a single, urn grave covered by a stone slab under which one quarry stone was found

¹⁷⁴ *Gradenjska hosta, Tum. 1-1896/Gr. 1-4*: Dular A. 1991, 35, T. 15: 1-4, 16, 17: 1,2.

¹⁷⁵ *Gradenjska hosta, Tum. V/1896*: *ibid.*, 35, T. 15: 5-15.

¹⁷⁶ *Gradenjska hosta, Tum. 7/1901*: *ibid.*, 36 f. The *machaira* hilt was published by V. Stare (1973a, T. 6: 12) and Frey (1980a, Abb. 2).

¹⁷⁷ Kromer 1959a, 58, T. 14; see also Dular/Križ 1990, 543 ff; Dular J. 2003, Abb. 59 A. For the fibula see Gabrovec 1970, 11, karta IV.

¹⁷⁸ Dular J. 1978, 19, fig. 3, T. 34; *id.* 1979, 83 ff; *id.* 1982, 174 ff, T. 4: 17.

¹⁷⁹ Gabrovec 1964-1965a, T. 1; Dular J. 1978, 18 f, T. 35: 1-3; *id.* 2003, 108 ff, Abb. 58A.

inventar groba pa je sestavljala tridelna garnitura posod (žara, lonec s stožčastim vratom in skleda).¹⁸⁰

Primere takih grobnih konstrukcij zasledimo že v planih žarnih grobiščih. V nekropoli Vrapče v Zagrebu je bilo odkritih nekaj grobov s kamnitimi skrinjami, ki so po besedah Ksenije Vinski-Gasparini predstavljali redkost in *novum* v tem prostoru. Datirala jih je v fazo II (Bd D/Ha A1) in nakazala povezave s kulturno skupino Baierdorf-Velatice.¹⁸¹ V Novem mestu so v Bršljinu prav tako našli skupino žganih grobov s kamnito konstrukcijo. V grobu 3 je kamnita skrinja jasno izpričana, medtem ko pri preostalih treh grobovih, ki so imeli kamnito ploščo na dnu jame, grobna konstrukcija ni povsem jasna, ker so bili poškodovani. Grob 3 je vseboval amforo, lonec, fragmente fibule očalarke, lasnega obročka s prepletom ter tordirane ovratnice, kar odraža čas mlajše žarnogrobiščne stopnje. Ob tem je zanimivo, da v žarnem grobišču na Mestnih njivah v Novem mestu takšne grobne konstrukcije niso znane.¹⁸²

Magdalenski gori najbližji primer takega pokopa je zabeležen na Molniku, kjer je bil odkrit v planem grobišču na Rojah. Gre za dvojni žarni pokop (gr. 5) iz časa stopnje Ljubljana IIIa. Eno žaro je predstavljal tradicionalni bikonični lonec z rahlo izvihanim ustjem, drugo pa glinasta situla z žebličastim okrasom; zraven so spadale še štiri posode, vaška vozlasta fibula s prirjavelo železno zapestnico, igla s kroglasto glavico in kos svinčene (?) pločevine.¹⁸³ Z dvorišča SAZU v Ljubljani so znani trije taki pokopi. V kamniti skrinji groba 92 so bile glinaste uteži za statve, vijčki in fragmenti podobno okrašene posode, kot jih je vseboval magdalenskogorski grob VI/10 s Prelog. Inventar groba 281 pa sestavljajo žara v obliki situle estensko-svetolucijskega tipa, dvoročajni lonček, skleda in kačasta fibula s sedlastim lokom. V grobu 267 je bila najdena vitka žara z množico obročastega nakita (zapestnice, tordirana ovratnica, trakasti uhani) in čolničasta fibula; čezenj pa je bila nasuta majhna gomilica (!). Te grobove lahko datiramo v čas stopnje Stična 2.¹⁸⁴

Na kratko se ozrimo še po severnih pokrajinah. Na Bledu je Narodni muzej leta 1953 raziskal naravno morensko tvorbo z videzom gomile, kjer so domačini pred tem našli na grob. Ob arheološkem kopanju sta prišla na dan še dva žgana pokopa, skupno torej trije. Grob 1 je bil z vseh strani obdan s kamnitimi ploščami, lomljenimi iz andezitnega porfirja oz. keratofirov. V njem je stala žara s kalcinirami kostmi in ogljem ter iglo z neornamentirano kroglasto glavico. Gabrovec

that supposedly represented one side of the cist; grave goods consisted of a three-piece set of vessels (urn, jar with a conical neck, bowl).¹⁸⁰

Cist graves already appeared in flat cemeteries from the Urnfield culture period. The Vrapče cemetery at Zagreb, Croatia, revealed several such examples that, according to Ksenija Vinski-Gasparini, represent a rarity and a novelty in the area. She dated the graves in Bd D / Ha A1 and pointed out ties with the Baierdorf-Velatice cultural group.¹⁸¹ Other cremation burials in a cist were documented at Bršljin in Novo mesto. Of those, a stone cist was clearly discernible in Grave 3, while for the other three graves this is only supposed on the basis of a slab lying on the bottom of the grave pit. Grave 3 contained an amphora, a jar, fragments of a spectacle fibula, hair-ring with interwoven wire, and a spirally twisted torque, which indicates the late Urnfield culture phase. It is noteworthy that such grave construction has not been documented at the urn cemetery at Mestne njive in Novo mesto.¹⁸²

The closest parallel to the cist burials of Magdalena gora was found at Molnik, more precisely in the flat cemetery at Roje. It is a multiple urn burial (Gr. 5) from the Ljubljana IIIa phase. Serving as the urn was the traditional biconical jar with a slightly everted rim and a ceramic situla decorated with bronze studs; found beside them were four vessels, a Vače type fibula with an iron bracelet rusted onto it, a spherical-headed pin and a piece of a lead (?) sheet.¹⁸³ Three such burials were also found at the SAZU courtyard in Ljubljana. The first was Grave 92, the stone cist of which contained clay loom weights, spindle whorls and fragments of a vessel decorated in a similar manner to the vessel in Grave VI/10 at Preloge. The second, Grave 281 contained an urn in the form of an Este-Sveta Lucija type situla, a small two-handled jar, a bowl and a serpentine fibula with a saddle-shaped bow. The third, Grave 267 contained a slender urn with a multitude of ring jewellery (bracelets, spirally twisted torque, band earrings) and a boat fibula; the grave was covered by a small earthen mound (!). These graves date to the Stična 2 phase.¹⁸⁴

Regions north of Dolenjska also revealed such burials. At Bled, the National Museum of Slovenia investigated in 1953 a natural moraine structure with the appearance of a tumulus, where the locals had found a grave. The investigation revealed further two cremation burials. Grave 1 had all four sides lined with slabs of quarried andesite porphyry or keratophyre, and contained an urn with calcified bones and charcoal as well

¹⁸⁰ Škoberne 1999, 23, sl. 7.

¹⁸¹ Vinski-Gasparini 1973, 17, 21 s, 44 s, 68–71, 130, 154 s, 187, T. 23: 5-9.

¹⁸² Knez 1967, 155 s, sl. 1–3, T. 1; *id.* 1966; *id.* 1984; Križ *et al.* 2009, 77.

¹⁸³ Puš 1984, 141, 149 ss, sl. 2, 3, T. 1: 5-10, 2: 1-3.

¹⁸⁴ Puš 1971, 17 s, T. 7: 4-16, 53; *id.* 1973; *id.* 1982, 113 s, 120 s, T. 3: 1-15, 4: 1-5, 8: 7-12, 63, 65.

¹⁸⁰ Škoberne 1999, 23, fig. 7.

¹⁸¹ Vinski-Gasparini 1973, 193 ff, T. 23: 5-9.

¹⁸² Knez 1967, 160, Abb. 1–3, T. 1; *id.* 1966; *id.* 1984; Križ *et al.* 2009, 77.

¹⁸³ Puš 1984, Abb. 2, 3, T. 1: 5-10, 2: 1-3.

¹⁸⁴ Puš 1971, 103, T. 7: 4-16, 53; *id.* 1973; *id.* 1982, 113 ff, T. 3: 1-15, 4: 1-5, 8: 7-12, 63, 65.

je v razpravi o prazgodovinskem Bledu, objavljeni leta 1960, te grobove primerjal z mariborsko-ruško žarnogrobiščno skupino in Dobovo. Datiral jih je v stopnjo Ha A in jih označil za ene izmed najstarejših žganih grobov na Slovenskem. Pozneje jih je opredelil kot posebno skupino grobov iz pozne bronaste dobe, ki jih ni mogoče uvrstiti niti v ljubljansko niti v dobovsko-ruško žarnogrobiščno skupino.¹⁸⁵

Na Koroškem je tak pokop znan z Napoleonovega travnika nad Beljaškimi Toplicami (Napoleonwiese über Warmbad Villach) iz časa okoli 800 pr. n. št. Kamnita skrinja v velikosti 65 x 80 x 70 cm je bila vkopana v prvotna tla in čeznjo nasuta gomilica. Razen štirih posod so bili v njej pridatki, ki kažejo na italško poreklo – igla, podobna tipu Numana-Sirolo, igla z narebreno glavico, zvit bronast polnoročajni meč tipa Nazari (najmlajši v tipološki skupini Calliano) ter britev in nož.¹⁸⁶ V gomilnih grobiščih koroške skupnosti na Bregu / Frögu je imel podobno kamnito konstrukcijo grob 1 iz gomile 181, ki je vseboval narebreno situlasto žaro, skodelo s prese-gajočim ročajem, dva vijčka, večglavo iglo s svitkastim zaključkom, železni sekiri (križno in z dvostranskimi plavutmi), *mahairo* in svinčeno figurico konjenika; grob je datiran v stopnjo Frög 3 (= čas stopnje Podzemelj).¹⁸⁷

Na Štajerskem se posamični pokopi v kamnite skrinje pojavljajo znotraj planih žarnih grobišč na mariborskem Pobrežju, na Lepi ravni pod Poštelo in v Šentjanžu pri Rečici na terasi Savinje.¹⁸⁸ V Kleinkleinu jih srečamo v gomilah ob koncu faze II oz. na začetku faze III, tj. v času Ha C2 oz. Ha D1 (Leitengritschwald 27, Grellwald 6 in 12). S stališča primerjav z Magdalensko goro je zanimiv inventar groba v gomili Leintengritschwald 27, v katerem nastopajo podobni pridatki kot v magdalenskogorskem grobu 12/1 z Laščika (železna sekira z dvostranskimi plavutmi, dve železni sulici ter barvani ciboriji).¹⁸⁹

Severno od Alp in v severozahodni Panoniji so tovrstne grobne konstrukcije poznane že od samega začetka kulture žarnih grobišč, posamično pa se pojavljajo še v času Ha C in Ha D1 tako znotraj planih grobišč kot v gomilah.¹⁹⁰

as a spherical-headed pin. Gabrovec, in his 1960 discussion on prehistoric Bled, paralleled these graves with the Maribor-Ruše Urnfield culture group and with Dobova, dating them to Ha A and determining as one the earliest cremation burials in Slovenia. Later, he determined them as a specific group of graves from the Late Bronze Age that could be classified neither in the Ljubljana nor in the Dobova-Ruše Urnfield culture group.¹⁸⁵

A cist burial in Carinthia was found at Napoleonwiese über Warmbad Villach, dating from roughly 800 BC. A stone cist measuring 65 x 80 x 70cm was constructed with its pit dug into the then ground and covered by a small earthen mound. It contained four vessels as well as goods pointing to an Italic origin, namely a pin resembling the Numana-Sirolo type, spherical-headed pin with a ribbed neck, bent solid-hilted bronze sword of the Nazari type (latest in the Calliano typological group), a razor and a knife.¹⁸⁶ Furthermore, the tumuli cemeteries of the Carinthia community at Frög include Grave 1 from Tumulus 181 with a similar stone construction, whereby the grave contained a ribbed situla-like urn, a cup with a high handle, two spindle whorls, a multi-knobbed pin, two iron axes (winged and lugged), a *machaira* and a lead figurine of a horseman. The grave is dated to the Frög 3 phase (= Podzemelj phase).¹⁸⁷

In the Slovene Štajerska region, individual burials in stone cists within flat urn cemeteries appear at Pobrežje in Maribor, at Lepa ravna below Poštela and at Šentjanž near Rečica, the latter on the terrace of the Savinja.¹⁸⁸ On the Austrian side, at Kleinklein, they were found in tumuli from the end of Phase II or beginning of Phase III, that is Ha C2 or Ha D1 (Leitengritschwald 27, Grellwald 6 and 12). The goods from the grave in Tumulus Leintengritschwald 27 are similar to those from Grave 12/1 at Laščik, namely an iron winged axe, two iron spearheads and painted footed bowls.¹⁸⁹

This type of grave construction appears north of the Alps and in north-western Pannonia at the very beginning of the Urnfield culture period, where it is also known individually in Ha C and Ha D 1 within both flat and tumulus cemeteries.¹⁹⁰

¹⁸⁵ Gabrovec 1960a, 7 ss, T. II: 1,3,4, IIa in XL; *id.* 1983, 70 f, 70 s, sl. 6: 2,3,7,10.

¹⁸⁶ Müller-Karpe 1959, Abb. 59; Teržan 1990a, 146, 185; Tomedi 1996, 176 ss, Abb. 4; Gleirscher 2008a, 213 ss, sl. 1–3.

¹⁸⁷ Tomedi 2002, 536 ss, Abb. 91, 92 in T. 83–84. Na tem najdišču najdemo analogije za inventar groba 12/1 na Magdalenski gori, tj. za železno sekiro z dvostranskimi plavutmi in za železne dereze: *ibid.*, 119 in 152 ss, Abb. 33.

¹⁸⁸ *Pobrežje*, gr. 25: Pahič 1972, 12, 31, 86, T. 48: spodaj; *Lepa ravna pod Poštelo*, gr. 14; *Šentjanž pri Rečici*, gr. 1: Teržan 1990a, 56, 112, 315, 368, sl. 44, 53, 54 in T. 59: 7-8, 80: 1-8.

¹⁸⁹ Dobiat 1980, 56, Abb. 3 (Steinkiste m. Brandbestattung), 6: 3,5 in T. 60: 4, 99: 1-13, 100: 1-8, Beil. 4.

¹⁹⁰ Schauer 1995, 148 ss, Abb. 31; Moosleitner 1992, 7 ss; Drack 1980.

¹⁸⁵ Gabrovec 1960a, 76, T. II: 1,3,4, IIa, XL; *id.* 1983, 70 f, fig. 6: 2,3,7,10.

¹⁸⁶ Müller-Karpe 1959, Abb. 59; Teržan 1990a, 146, 185; Tomedi 1996, 176 ff, Abb. 4; Gleirscher 2008a, 213 ff, Abb. 1–3.

¹⁸⁷ Tomedi 2002, 536 ff, Abb. 91, 92 and T. 83–84. It is possible to find analogies for the finds from Grave 12/1, namely for the iron winged axe and iron crampons, at Magdalenska gora: *ibid.* 119 and 152 ff, Abb. 33.

¹⁸⁸ *Pobrežje*, Gr. 25: Pahič 1972, 12, 31, 86, T. 48: bottom; *Lepa ravna below Poštela*, Gr. 14; *Šentjanž near Rečica*, Gr. 1: Teržan 1990a, 56, 112, 315, 368, figs. 44, 53, 54 and T. 59: 7-8, 80: 1-8.

¹⁸⁹ Dobiat 1980, 56, Abb. 3 (Steinkiste m. Brandbestattung), 6: 3,5 and T. 60: 4, 99: 1-13, 100: 1-8, Beil. 4.

¹⁹⁰ Schauer 1995, 148 ff, Abb. 31; Moosleitner 1992, 7 ff; Drack 1980.

V zaledju severnega Jadrana so pokopi *a cassetta* oz. *a cassetina* predstavljal tako rekoč pravilo v estenski skupnosti vse od konca 9. pa tja do konca 4. st. pr. n. št.¹⁹¹ V vodilni nekropoli svetolucijske skupnosti so izpričani približno v istem času kot na Dolenjskem in še kasneje, medtem ko jih v zgodnejši formativni fazi, ki jo predstavlja tolminska skupnost, ni opaziti.¹⁹² Tudi v Istri so zastopani v širokem časovnem razponu od stopnje Istra I do VI. Pokope v istrskih železnodobnih nekropolah je analizirala Vojka Cestnik in pokazala, da so kamnite skrinje predstavljale prevladujočo grobno konstrukcijo v grobiščih v Puli, Picugih in Kaštelu nad Bujami, medtem ko so v Nezakciju, Limski gradini, Rovinju in Beramu zastopane s cca. 10- do 25-odstotnim deležem. V Kaštelu pri Bujah se v grobovih s kamnitimi skrinjami pojavljajo npr. glinaste situle estensko-svetolucijskega tipa in apulski krater, ki jih v drugih vrstah grobov ne zasledimo.¹⁹³

Namen tega grobega in nepopolnega pregleda je bil prepoznati izvorno območje tovrstnih grobnih konstrukcij, ki niso tipične za dolensko halštatsko skupnost niti niso bile za ljubljansko žarnogrobiščno skupino. Videti je, da se ta fenomen pojavlja razpršeno na širokem prostoru v različnih kulturnih sredinah in v daljšem časovnem razponu ter da je v starejši železni dobi značilen predvsem za severnojadranski prostor.

V dolenski halštatski sredini so bili žgani grobovi s kamnitimi skrinjami vključeni v grobišča lokalnega prebivalstva in so mnogokrat vsebovali netipični inventar, zato bi lahko domnevali, da gre za pokope tujcev, ki so se bolj ali manj integrirali v lokalno okolje, ali pa za osebe, ki so imele poseben družbeni položaj.

ŽGANI GROBOVI Z LESENO PODLOGO?

V poročilih z izkopavanj se v nekaterih žganih grobovih omenjajo nekakšni leseni elementi. Szombathy je v svojem dnevniku v zvezi z grobom 13/10 s Prelog (sl. 29) zapisal: "Holzbalken ganz in Kohle verwandelt, 18 cm breit, ca. 20 cm hoch; gegen die Mitte zu bildet das Holz eine 45-50 cm tiefe Mulde. Unter a ein besonders großer Schleifstein in der Erde stehend, zu seiner Füßen bei c ein eiserner Gürtelhaken. 35 cm unter dem Troge eine 3 cm dicke schwarze Holzschichte, auf dieser die Funde. d. Dolch mit Brscheide, e 2 Lanzenspitzen, f bauchiges

¹⁹¹ Chieco Bianchi/Calzavara Capuis 1985, 496 (*tombe a cassetta*), Fig. 3–6, T. VIII–X; Calzavara Capuis/Chieco Bianchi 2006, T. XVIII, XXVIII; Leonardi/Cupitó 2011. Kamnite skrinje so znane še z drugih najdišč, npr. *Montebelluno*: Manessi/Nascimbene 2003, 33 ss, Tab. 1.

¹⁹² *Most na Soči*, gr. 467, 308: Teržan/Lo Schiavo/Tram-puž-Orel 1984/1985, 85, 104, T. 28B, 40C.

¹⁹³ Gabrovec/Mihovilić 1987, 303 s, 321 s; glej npr. *Nezakcij*: Mihovilić 2001, 30 ss, sl. 34, 37, 128, T. 36: 4-13, 41: 1-18, 42: 3-7, 45: 19, 46: 1-5, 21-36, 48: 1-8, 50: 2-18; Cestnik 2009, 126 ss, sl. 43, T. 2: 1, 2: 2, 6: 1, 12: 1, 22: 6, 28: 1, 31: 2, 32: 5.

On the other hand, the so-called graves *a cassetta* or *a cassetina* are characteristic of the Este community, where they almost represent a rule from the end of the ninth to the end of the fourth centuries BC.¹⁹¹ The leading cemetery of the Sveta Lucija community reveals cremation burials in cists at roughly the same time as in Dolenjska as well as later, while they appear to be absent in the earlier, formative phase represented by the Tolmin community.¹⁹² In Istria, they appear in Phases I to VI. Burials in the Iron Age cemeteries of Istria were analysed by Vojka Cestnik, who showed that stone cists represented the predominant grave construction at Pula, Picugi and Kaštel near Buje, while at Nesactium, Limska gradina, Rovinj and Beram cists were found in 10 to 25 per cent of graves. Moreover, at Kaštel near Buje, goods in stone cists included, among others, clay situlae of the Este-Sveta Lucija type as well as an Apulian *krater*, which were not documented in graves with other constructions.¹⁹³

The aim of this brief and incomplete overview was to identify the area of origin for burials in stone cists, which are uncharacteristic for both the Dolenjska Hallstatt community and its predecessor, the Ljubljana Urnfield culture group. The overview indicated that the phenomenon is scattered across a wide area, across different cultural milieus and across long periods of time, but also that in the Iron Age it was most common in the northern Adriatic area.

Cremation burials in cists in the Dolenjska Hallstatt community were included within cemeteries of the local population and frequently contained uncharacteristic grave goods. This would allow these graves to be seen as burials of either foreigners, who were more or less integrated in the local surroundings, or persons of a special social status.

CREMATION GRAVES WITH A WOODEN BEDDING?

The descriptions of Graves 13/10, 13/24 and 13/105 from Tumulus 13 at Prelog reveal some sort of wooden elements. In connection with Grave 13/10 (fig. 29), Szombathy wrote in his diary, "Holzbalken ganz in Kohle verwandelt, 18 cm breit, ca. 20 cm hoch; gegen die Mitte zu bildet das Holz eine 45-50 cm tiefe Mulde. Unter a ein besonders großer Schleifstein in der Erde stehend, zu seiner

¹⁹¹ Chieco Bianchi/Calzavara Capuis 1985, 496 (*tombe a cassetta*), Figs. 3–6, T. VIII–X; Calzavara Capuis/Chieco Bianchi 2006, T. XVIII, XXVIII; Leonardi/Cupitó 2011. Stone cist graves are also known from other sites, i.e. *Montebelluno*: Manessi/Nascimbene 2003, 33 ff, Tab. 1.

¹⁹² *Most na Soči*, Gr. 467, 308: Teržan/Lo Schiavo/Tram-puž-Orel 1984/1985, 85, 104, T. 28B, 40C.

¹⁹³ Gabrovec/Mihovilić 1987, 303 f, 321 f; see for example *Nesactium*: Mihovilić 2001, 30 ff, figs. 34, 37, 128, T. 36: 4-13, 41: 1-18, 42: 3-7, 45: 19, 46: 1-5, 21-36, 48: 1-8, 50: 2-18; Cestnik 2009, 126 ff, fig. 43, T. 2: 1, 2: 2, 6: 1, 12: 1, 22: 6, 28: 1, 31: 2, 32: 5.

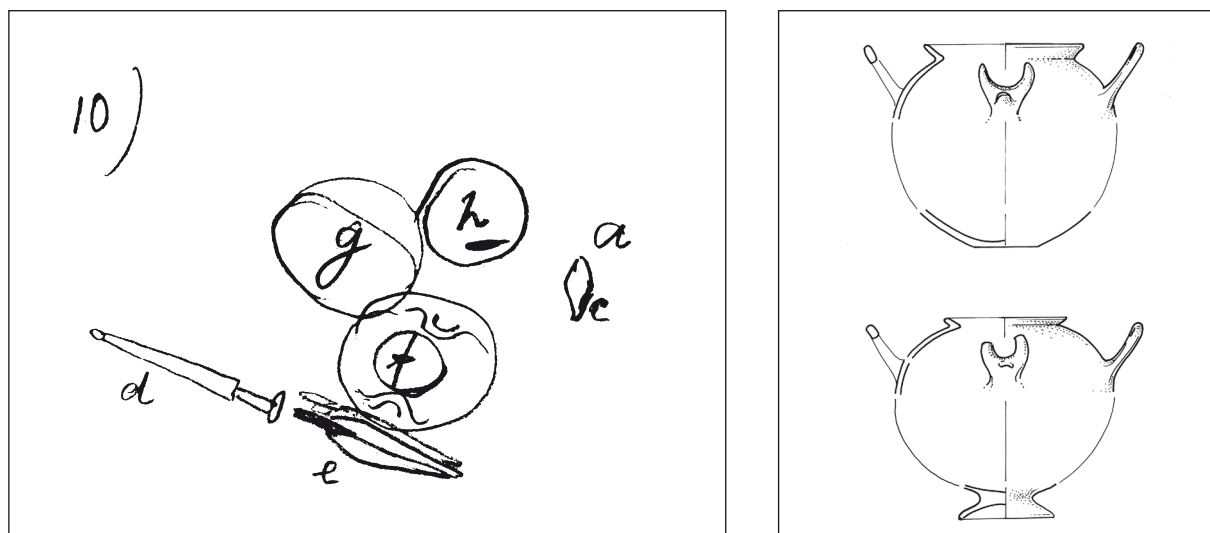

Sl. 29: Szombathyjeva skica groba 13/10 ter apulska kraterja iz tega groba v merilu 1:5
(po Tecco Hvala/ Dular/Kocuvan 2004, sl. 29 in T. 69: 8, 9).

Fig. 29: Szombathy's sketch of Grave 13/10 and a drawing of the two Apulian *kratere* from this grave, in the scale of 1:5
(after Tecco Hvala/Dular/Kocuvan 2004, Abb. 29 and T. 69: 8, 9).

griech. Gefäß mit 2 Henkeln, gelb. g detto roth. h. schwarze Fußurne mit 5 Warzen, zu Füßen ein Eisenmesserchen. Brandgrab. Beim Abgraben der Stelle von Grab 10 ein Beschlagstück aus Eisen." Omenjene grške posode so pravzaprav apulski kraterji, ki so poznani še z nekaterih drugih belokranjskih in zahodnodolenjskih najdišč, kamor so jih v drugi polovici 7. st. pr. n. št. prinesli prek Istre z zahodnojadranske obale. Največ apulskih kraterjev je znanih iz Stične. V dolenski halštatski skupnosti so jih tudi posnemali, kar kažejo primerki iz Dobrnica in Dragatuša, ki se od uvoženih razlikujejo po strukturi lončarske mase in okrasu.¹⁹⁴

Na podlagi Brattinovega opisa magdalenskogorskega groba 13/24 s Prelog in zlasti po njegovi skici bi si lahko ustvarili vtis, da je bila za podlogo uporabljena lesena deska ali bruno, ki je bilo v sredini izdolbeno (sl. 17: C), v vdolbino je bil nasut pepel, nanj pa položeni predmeti. Ohranjene črepinje barvane posode kelihaste oblike in kaneliran trakasti uhan odražajo značilnosti svetolucijske skupnosti.

Podobno strukturo je moral videti tudi v grobu 13/105, o katerem je takole poročal: "Brandgrab ohne Platte. [...] Um das ganze Grab liegen Schichten einer schwarzen Masse. Kohle von Brettern herrührend. Diese Kohlschichten sind auf der Schmalseite gekrümmt." Poleg črne sodčasto oblikovane žare z žganino je stal barvan svetolucijski pitos, v katerem je bilo pet glinastih kroglic. Vsi trije grobovi z lesenimi elementi so očitno vsebovali prvine, ki niso lokalnega značaja.

¹⁹⁴ Frey 1966, 60 s, Abb. 12; id. 1969, 76 ss; Dular J. 1982, 57 ss; Bergonzi 1984; Mihovilić 2001, sl. 70, 76, 77, 84, 85; Teržan 1995b, 98 ss, Abb. 15; Turk/Murgelj 2008; Cestnik 2009, 31 ss, sl. 13.

Füßen bei c ein eiserner Gürtelhaken. 35 cm unter dem Troge eine 3 cm dicke schwarze Holzschichte, auf dieser die Funde. d. Dolch mit Brscheide, e 2 Lanzenspitzen, f bauchiges griech. Gefäß mit 2 Henkeln, gelb. g detto roth. h. schwarze Fußurne mit 5 Warzen, zu Füßen ein Eisenmesserchen. Brandgrab. Beim Abgraben der Stelle von Grab 10 ein Beschlagstück aus Eisen". The Greek vessels mentioned are actually Apulian *kratere*, such as are known from several other sites in Bela krajina and western Dolenjska, brought there from the west coast of the Adriatic via Istria in the second half of the seventh century BC. The greatest number of these *kratere* was found at Stična. The product even sparked off imitations in the Dolenjska community, as evidenced by the examples from Dobrnica and Dragatuš, which differ from the imports in clay fabric and decoration.¹⁹⁴

The description of Grave 13/24, provided by Brattina, and even more so his sketch of the grave, indicates that a wooden board or timber was used as the bedding, hollowed out in the centre (fig. 17: C); the hollow was then filled with the ashes and on it grave goods were placed. The latter included shards of a painted goblet-shaped vessel and a grooved band earring that reflect characteristics of the Sveta Lucija community.

Brattina must have discerned a similar structure in Grave 13/105, of which he reported thus, "Brandgrab ohne Platte. [...] Um das ganze Grab liegen Schichten einer schwarzen Masse. Kohle von Brettern herrührend. Diese Kohlschichten sind auf der Schmalseite gekrümmt."

¹⁹⁴ Frey 1966, 60 f, Abb. 12; id. 1969, 76 ff; Dular J. 1982, 189 f; Bergonzi 1984; Mihovilić 2001, figs. 70, 76, 77, 84, 85; Teržan 1995b, 98 ff, Abb. 15; Turk/Murgelj 2008; Cestnik 2009, 31 ff, fig. 13.

O lesenih strukturah v žganih grobovih

Lesene konstrukcije v žganih grobovih na Dolenjskem niso izpričane. V ljubljanski žarnogrobiščni nekropoli je zabeležen le en grob iz časa stopnje Ljubljana IIb, ki je bil pokrit z leseno desko (gr. 71); v njem je stala bikonična žara s poveznjeno skodelo in še en lonec, k pridatkom v žari pa sta spadala fragment železnega noža in bronasta igla s polkroglasto glavico in tremi svitki na vratu.¹⁹⁵ V svetolucijskem grobišču na Mostu na Soči se lesena obloga omenja v grobu 729, ki je vseboval bronasto cisto in več različnih fibul iz časa stopnje Sv. Lucija IIb.¹⁹⁶

Žgani grobovi z leseno konstrukcijo se pojavljajo v zaledju zahodnojadranske obale v središčih, kot so Fermo, Verucchio, Altino ali Montebelluno.¹⁹⁷ V Verucchio sta imela leseno konstrukcijo znamenita grobova Lippi 85 in 89 z različnimi tipi čelad, med katerimi nastopata tudi stožčasta in skledasta čelada (t. i. šmarješki tip), ki imata povezave v dolenski halštatski skupini.¹⁹⁸ V karnijskih Alpah so v nekropoli Misincinis pri Paularu odkrili žarne grobove iz obdobja od konca 8. do začetka 4. st. pr. n. št., ki so bili vkopani v prvotna tla in so imeli lesene konstrukcije v obliki zaboja ali skrinje. Na dno lesenega zaboja so potresli sežgane ostanke z grmade, nanje pa položili žaro s kostmi in pridatki. Grob so pokrili z leseno desko ali kamnito ploščo, čeznjo pa nasuli gomilico zemlje in kamnitega drobirja. Takšne lesene konstrukcije so izpričane tudi v grobiščih na severnem in vzhodnem obrobju Alp.¹⁹⁹

Iz opisov magdalenskogorskih grobov 10, 24 in 105 v gomili 13 na Prelogah ni moč razbrati, da bi bili vsebovali lesene skrinje ali opaž, morda je šlo le za ostanke grmade, ki so jih položili na dno jame, nanje pa zložili predmete in žaro z zbranimi ostanki kosti. Možno pa bi bilo tudi, da sploh ni šlo za žgani pokop, temveč za ostanke lesene krste. Ta dvom se poraja v zvezi z grobom 13/10, ki je vseboval apulska kraterja, takšno posodje pa se v dolenskih gomilah običajno pojavlja v skeletnih grobovih.²⁰⁰

¹⁹⁵ Puš 1971, 9, T. 1: 1-5.

¹⁹⁶ Teržan/Trampuž 1973, 432, pril. 1; Teržan/Lo Schiavo/Trampuž-Orel 1984 in 1985, 143, T. 72A.

¹⁹⁷ *La protostoria tra Sile e Tagliamento* 1996, Fig. 12; *Eroi e regine: Piceni Popolo d'Europa* 2001, 55-85, 299-336; Gentili 2003, 293, Fig. 57, 58, T. XI, XIV, XV; Corazza/Vitri (ur.) 2001; Manessi/Nascimbene 2003, 37, 271, 279, 284.

¹⁹⁸ Gentili 2003, T. 135: 40, 151: 53; Teržan 2007a, 43 s, Fig. 1 in 6. Ob tem velja izpostaviti, da je skledasta čelada iz Verucchia podobna molniški; Škoberne jo je uvrstil v skupino Molnik, v katero spadajo še primerki iz okolice Velikega Vinjega vrha (Šmarjete), Stične, Bleda, Hallstatta in Mitterkirchna (Škoberne 1999, 68 ss, sl. 58 in 67).

¹⁹⁹ Npr. *Uttendorf*: Moosleitner 1992, 42 s. Za Štajersko in severozahodno Panonijo glej Teržan 1990a, 38, 56 s, 126 s, 159, 166.

²⁰⁰ Turk/Murgelj 2008, 167 ss, sl. 11.

Beside the black barrel-shaped urn with cremated remains stood a painted Sveta Lucija-type pithos that contained five clay balls. It is clear from the above that all three graves included elements that are not a typical local expression of the Dolenjska Hallstatt community.

On wooden structures in cremation graves

The cremation graves of Dolenjska did not reveal wooden constructions. In its vicinity, a single such grave was documented in the Urnfield culture cemetery at Ljubljana, from Phase IIb. The grave in question (Gr. 71) was covered by a wooden board and contained a biconical urn with a bowl on top and a jar, whereby the urn contained a fragment of an iron knife and a bronze hemispherical-headed pin with a ribbed neck.¹⁹⁵ The second such grave was found at the Sveta Lucija cemetery at Most na Soči, where a wooden lining is mentioned for Grave 729, which contained a bronze cist and several different fibulae from the Sveta Lucija IIb phase.¹⁹⁶

Cremation graves with a wooden construction appear in the hinterland of the northern Adriatic coast, in centres such as Fermo, Verucchio, Altino and also Montebelluno.¹⁹⁷ At Verucchio, a wooden construction was found in the famous graves Lippi 85 and 89 that contained different types of helmets, among them also a conical and a bowl-shaped (so-called Šmarjeta type) helmet that point to connections with the community of Dolenjska.¹⁹⁸ The cemetery at Misincinis near Paularo, in the Carnian Alps, revealed urn graves from the end of the eighth to the beginning of the fourth centuries BC period, with the grave pit dug into the ground and a wooden cist made in it. The bottom of the wooden cist was strewn with cremated remains from the pyre and the urn containing human remains and grave goods. Graves were covered with a wooden board or a stone slab, all of which was then covered over by a small mound of earth and small stones. Such wooden constructions are attested to also on the northern and eastern fringes of the Alps.¹⁹⁹

To return to Graves 10, 24 and 105 from Tumulus 13 at Preloge, their descriptions do not allow us to

¹⁹⁵ Puš 1971, 9, T. 1: 1-5.

¹⁹⁶ Teržan/Trampuž 1973, 437 ff, all. 1; Teržan/Lo Schiavo/Trampuž-Orel 1984 and 1985, 143, T. 72A.

¹⁹⁷ *La protostoria tra Sile e Tagliamento* 1996, Fig. 12; *Eroi e regine: Piceni Popolo d'Europa* 2001, 55-85, 299-336; Gentili 2003, 293, Fig. 57, 58, T. XI, XIV, XV; Corazza/Vitri (eds.) 2001; Manessi/Nascimbene 2003, 37, 271, 279, 284.

¹⁹⁸ Gentili 2003, T. 135: 40, 151: 53; Teržan 2007a, 43 f, Figs. 1 and 6. Škoberne ascribed the bowl-shaped helmet from Verucchio to the Molnik group together with the examples from Veliki Vinji vrh (Šmarjeta), Stična, Molnik, Bled, Hallstatt and Mitterkirchen (Škoberne 1999, 68 ff, figs. 58, 67).

¹⁹⁹ For example, *Uttendorf*: Moosleitner 1992, 42 f. For Štajerska (Styria) and north-eastern Panonnia see Teržan 1990a, 38, 56 f, 126 f, 159, 166.

V žganih pokopih se zrcalijo kompleksni procesi formiranja dolenske halštatske skupnosti. Najstarejše žgane grobove na Magdalenski gori bi lahko datirali v čas Ljubljane IIa, ki se po ritualu in oblikah žar navezujejo na žarnogrobiščno tradicijo. Vendar se je sežiganje pokojnikov na Magdalenski gori nadaljevalo vzporedno s pokopavanjem celih trupel v gomile vse tja do sredine 6. st. pr. n. št., ko je bila drugod na Dolenjskem ta navada v glavnem že opuščena. O dvojnem pogrebnem ritualu jasno pričajo grobovi s Prelog z enakimi opravami pokojnih (žgani grob VI/2 *versus* skeletni grob 13/48 ali pa žgani pokop 13/163 *versus* skeletni pokop VII/40). Zgovoren primer biritualnega pokopa je znan tudi s sosednjega najdišča: na uro hoda oddaljenem Molniku sta bili na planem žarnem grobišču na Rojah skupaj pokopani dve deklici, kjer je bila pri nogah okostja 15-letnice postavljena žara s sežganimi posmrtnimi ostanki deklice, stare med 7 in 14 let.²⁰¹

Poleg lokalnega žarnogrobiščnega izročila je na Magdalenski gori moč zaznati tudi take grobne konstrukcije in posebnosti, kot so kamnite skrinje, prekrivanje žar s tkanino ter nekatere pridane (bronasto posodje, estenski in svetolucijski tipi lončenine, apulska keramika, sestavljena čelada idr.), ki v tem okolju niso običajni. Navezujejo se na najbogatejše moške in ženske pokope iz časa stopnje Stična,²⁰² kar bi govorilo o posebnem statusu teh pokojnikov in njihovih zvezah z drugimi kulturnimi sredinami.

3.2.2 SKELETNI GROBOVI

Bolj kot sežiganje je bilo pri prebivalcih Magdalenske gore v navadi pokopavanje celih trupel pokojnikov v gomile (*sl. 12: B*). V eni gomili je bilo običajno pokopanih več oseb in generacij, ki pripadajo različnim spolnim in starostnim skupinam (moški, ženske in otroci). Razen tega so v rastru grobišča vidna grupiranja gomil na določenih mestih in vmesne praznine, s čimer se nakazuje delitev nekropole na več enot, ki na svojstven način povnanjajo strukturo te skupnosti. Ob predpostavki, da prostorska bližina pokopov izraža tesnejšo zvezo med člani in genealoški spomin na preminule, bi lahko v gomili in gručah gomil slutili nekakšne družinsko-rodovne zveze.²⁰³

²⁰¹ Puš 1984, 146, sl. 8; Tomazo-Ravnik 1984, 164 s.

²⁰² Laščik, *gr. 4/1, 12/1; Preloge, gr. 13/10, 13/95, 13/101, 13/163; Voselca, gr. 6/1.*

²⁰³ Gabrovec 1987, 85 ss; Dular/Tecco Hvala 2007, 247; Teržan 2008, 191 ss. Tak način pokopa v gomile družinsko-rodovnega tipa je značilen za klasični ilirski skupini *Glasiac* v Bosni in *Matí* v Albaniji, čeprav z Dolenjsko v materialni kulturi nimata veliko stičnih točk (Gabrovec 1964–1965a, 43 ss; id. 1987, 89 in 117 ss; Teržan 2008, 233). Idejo družinske gomile oz. parcele ter skeletni pokop je prav tako možno zaslediti na italjskem polotoku: glej razprave v Naso (ur.) 2011. Na območju Abruzzov je bila npr. v močvirju pri

discern possible wooden cists or lining; the wooden remains might simply represent the remains of the pyre placed on the bottom of the grave pit, and grave goods and the urn with selected bone remains placed on top of it. The graves could also have contained remains of wooden coffins without preserved bones. The latter is possible for Grave 13/10 with Apulian *kratere* with regards to the fact that this pottery type was found in the Dolenjska tumuli in inhumation graves.²⁰⁰

Cremation burials mirror the complex formative processes of the Dolenjska Hallstatt community. At Magdalenska gora, the earliest cremation burials could be dated to the Ljubljana IIa phase, relating to the Urnfield culture tradition in both ritual and urn form. Cremation at the site continued alongside inhumation burials in tumuli all to the mid-sixth century BC, when the practice of cremating the dead elsewhere in Dolenjska was mainly abandoned. The dual funerary ritual is clearly evidenced by the graves from Preloge with the same costumes of the deceased (cremation Grave VI/2 *versus* inhumation Grave 13/48; cremation Grave 13/163 *versus* inhumation Grave VII/40). A telling example of a biritual burial is also known from the nearby site of Molnik, an hour's walk from Magdalenska gora. Its flat urn cemetery at Roje revealed a common burial of two girls, whereby the urn containing the remains of a girl aged 7–14 was placed at the feet of the skeleton of a 15-year-old girl.²⁰¹

Apart from the local Urnfield culture tradition, the graves of Magdalenska gora also revealed grave constructions and other particularities, such as stone cists, wooden bedding, covering of urns with a piece of cloth as well as certain grave goods (bronze vessels, Este and Sveta Lucija pottery types, Apulian ware, composite and conical helmets, iron crampons) that are not usual for the region. These were found in the richest graves, male and female, from the Stična phase,²⁰² which would point to a special status of these deceased and their ties to other cultural milieus.

3.2.2 INHUMATION BURIALS

More than cremation, the inhabitants of Magdalenska gora practiced inhumation burial into tumuli (*fig. 12: B*). One tumulus usually served to bury several deceased of several generations of different sex and age groups (male, female and children). Apart from that, the layout of the cemetery shows concentrations of

²⁰⁰ Turk/Murgelj 2008, 167 ff, Abb. 11.

²⁰¹ Puš 1984, Abb. 8; Tomazo-Ravnik 1984, 164 f.

²⁰² Laščik, *Gr. 4/1, 12/1; Preloge, Gr. 13/10, 13/95, 13/101, 13/163; Voselca, Gr. 6/1.*

O grobnih konstrukcijah

O grobni arhitekturi in legi skeletnih grobov v gomili ni prav veliko podatkov. Izkopavalci so v glavnem navajali globine grobov, ki so jih odmerili od površja, zato si z njimi ne moremo kaj prida pomagati. Velikost grobne jame je mestoma zabeležil le Goldberg. Na podlagi njegovih podatkov je moč sklepati, da so bile mere precej standardne; grobne jame so običajno merile okoli 3 x 1 m, širši je bil dvojni grob VIII/17–18 (2,1 m) s Prelog, manjši (2 x 0,7 m) pa grob 21 iz gomile IV na Prelogah.

V virih je večkrat omenjeno, da je dno jame prekrivala tanka plast žganine, na kateri je ležalo okostje.²⁰⁴ Zelo verjetno je šlo za strohnelo leseno podlogo ali ostanke krste, kakršne so dobro znane iz stiških in novomeških grobov.²⁰⁵ O lesenih krstah Pečnik izrecno govori v opisih grobov 2/h, 2/n in 2/13 s Prelog. Slednji je po njegovih besedah meril 4 x 2 m, krsto pa je takole opisal: "[...] *die Leiche in eine hölzerne Truge gelegt, aber nicht aus Laden, sondern aus dicken Holz, oder war mit Holztrüme gelegt [...]* Vitez in konj sta ležala v debeli krsti, narejeni iz hlodov."²⁰⁶ Dobro je morala biti ohranjena tudi krsta v grobu 13/136, ki jo je Brattina skiciral v svojem dnevniku (sl. 30). Grob 2/n je bil menda obdan še z velikimi kamni.

Po Goldbergovih navedbah je bila v sredini gomile VI na Prelogah kamnita groblja, sredi katere so odkrili grob (VI/12). Kamne so postavljali tudi v vogale grobne jame ali pa so pokojnega položili na kamnito podlago in prekrili z gruščem.²⁰⁷

Celanu odkrita gomila iz časa 13.–11. st., ki je bila obdana s kamnitim vencem, znotraj katerega je ležalo 7 skeletnih grobov, centralni pokop pa je vseboval lesen sarkofag, izdelan iz hrastovega debla. Iz časa 10.–4. st. pr. n. št. so na najdišču *Fossi* izpričane gomile s kamnitim vencem in s centralnimi skeletnimi grobovi, obdanimi s kamenjem, med grobnimi pridatki pa nastopa tudi orožje (*Eroi e Regine: Piceni Popolo d'Europa* 2001; Cosentino/d'Ercole/Mieli 2003, fig. 2, 5; *Piceni ed Europa* 2007, 41, 43 s, 58, 66 ss, 73 ss). V grobiščih *Novilare* so zabeleženi skeletni pokopi iz 8.–6. st. pr. n. št., ki so ležali v različnih smereh in v skrčeni legi znotraj družinske gomile ali grobnih parcel (Beinhauer 1985, 24 ss, Fig. 3 in 4; Bergonzi 1992, 64, Fig. 3–5); v *Corvaru* je bila raziskana gomila iz 7. st. pr. n. št. s 44 skeletnimi pokopi v iztegnjeni legi na hrbtu (Alvino 1992, Fig. 1 in 4); v *Fabrianu* so znane gomile s centralnim grobom in naknadnimi pokopi iz 7. st. pr. n. št. (Sabbatini 2003, 184 ss) itd.

²⁰⁴ Tecco Hvala/Dular/Kocuvan 2004, 104, op. 286.

²⁰⁵ Križ 1997, T. 4, 10, 19, 27, 49, 59, 66; id. 2000, T. 8, 11, 13, 18, 20, 22, 28, 30, 33–35, 40–42, 44. Gabrovec et al. 2006, sl. 3–5, 12, 17–19, 27, 30, 33, T. 3, 37, 61, 70, 74, 75, 77, 97, 102.

²⁰⁶ Tecco Hvala/Dular/Kocuvan 2004, 35.

²⁰⁷ Lašič, gr. V/3; Preloge, gr. IV/20, VI/8, VI/17, VI/37, VII/4; ibid., 104 s, op. 287–294.

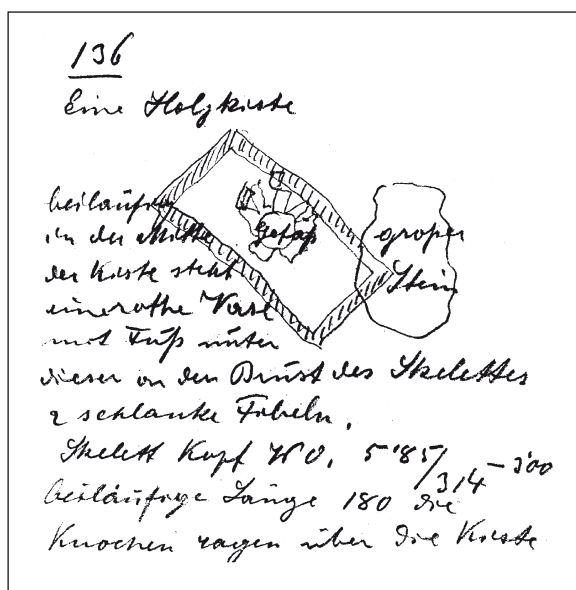

Sl. 30: Lesena krsta v grobu 13/136 (po Tecco Hvala/Dular/Kocuvan 2004, sl. 36).

Fig. 30: Wooden coffin in Grave 13/136 (after Tecco Hvala/Dular/Kocuvan 2004, Abb. 36).

tumuli with empty areas in between, which indicates a segmentary community. Presuming that the spatial proximity of burials signifies close ties among members and a genealogical memory of the dead, the tumulus and groups of tumuli could be perceived as reflecting ties of family and clan.²⁰³

²⁰³ Gabrovec 1987, 85 ff; Dular/Tecco Hvala 2007, 247; Teržan 2008, 191 ff. The family type of tumuli with inhumation burials is primarily characteristic of the prehistoric Illyrian communities in Bosnia (*Glasinac*) and Albania (*Mati*), whereby they did not reveal many common elements in the material culture with the Dolenjska Early Iron Age community (Gabrovec 1964–1965a; id. 1987, 89, 117 ff; Teržan 2008, 233). The idea of a family tumulus and inhumation rite can be traced across a wider area, for example in central Italy (see treatises in Naso (ed.) 2011). A tumulus dated from the thirteenth to the eleventh centuries BC unearthed near *Celano* in Abruzzi was encircled by a stone ring and revealed 7 inhumation graves; the central grave contained an oak coffin. Other examples are known from *Fossi*, where tumuli from the tenth to the fourth centuries BC were encircled by stone rings and contained central graves and also burials with weapon (*Eroi e Regine: Piceni Popolo d'Europa* 2001 and also Cosentino/d'Ercole/Mieli 2003, fig. 2, 5 and *Piceni ed Europa* 2007, 41, 43 f, 58, 66 ff, 73 ff). In the cemeteries of *Novilare*, inhumation graves from the eighth to the sixth centuries, of different orientations and in a contracted position, were found within tumuli or burial plots (Beinhauer 1985, 24 ff, Figs. 3, 4; Bergonzi 1992, 64, Figs. 3–5). Excavations in *Corvaro* revealed a tumulus from the seventh century BC with 44 inhumation burials (Alvino 1992, Figs. 1, 4). Tumuli from the seventh century BC with a central grave and subsequent burials are also known at *Fabiano* (Sabbatini 2003, 184 ff) etc.

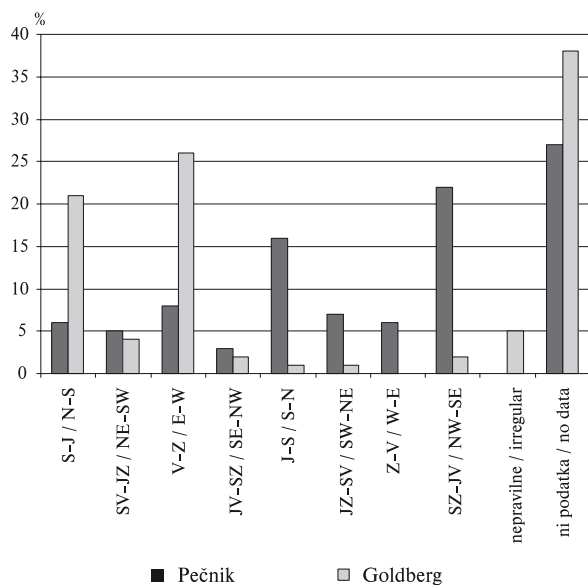

Sl. 31: Primerjava smeri pokopov z izkopavanj Pečnika in vojvodinje Mecklenburške.

Fig. 31: Comparison of orientations of burials from excavations of Pečnik and the Duchess of Mecklenburg.

O smereh pokopov in legi okostij

V opisih grobov so podane približne usmeritve okostij, vendar ti podatki brez tlorisnih načrtov niso kdo ve kako uporabni. Zanimivo je, da je v gomilah, ki jih je prekopal Pečnik (sl. 31), zabeleženih največ pokopov v smeri SZ–JV (52 primerov) in J–S (38 primerov), medtem ko se v gomilah, ki jih je raziskala vojvodinja Mecklenburška (sl. 31), največkrat omenjata usmeritvi V–Z (56 primerov) in S–J (45 primerov). Vzorca usmeritev sta torej precej različna in zato dvomljiva, smiselnost nadaljnjih analiz pa vprašljiva. Kljub vsemu velja pripomniti, da ni opaziti pomenljivih korelacij med določeno smerjo pokopa in spolom, starostjo ali statusom pokopanega.

Pokojnike so v grob položili v iztegnjenem položaju na hrbet in z rokami ob telesu, kar je nazorno razvidno tudi iz fotografske in risarske dokumentacije (sl. 34 in sl. 37).²⁰⁸ Manjše odstopanje od ustaljenega pravila je zabeležil Brattina v grobu 13/100 na Prelogah (sl. 32), kjer je okostje ležalo v gomili na goli skali; levi okončini je imelo pokrčeni, ob njem pa ni bilo nikakršnih pridatkov. Ta neobičajna lega je lahko povsem naključna, lahko pa bi predstavljala napol skrčen pokop ali patološki pojav oz. telesno okvaro.²⁰⁹ Odklon od premočrtne osi je moč razbrati v 5 odstotkih pokopov, vendar ni jasno, ali je šlo dejansko za skrčen položaj okostja ali zgolj za neljubo

²⁰⁸ Hencken 1978, Fig. 242, 244, 271, 278, 289, 298, 309, 311, 316, 325, 340, 342, 356; Tecco Hvala/Dular/Kocuvan 2004, sl. 31.

²⁰⁹ O nenavadnih položajih skeletov glej Pauli 1975, 174 ss.

On grave constructions

There is not much information available on the grave constructions and position of the skeletons within tumuli. The excavators in their reports mainly stated depth of graves measured from the surface, which is now practically useless information. Grave pit size was sometimes noted only by Goldberg. Based on the latter, the pits must have been of a more or less standard size; usually measuring roughly 3 x 1m, wider being multiple Grave VIII/17–18 (2.1m) and smaller (2 x 0.7m) Grave 21 from Tumulus IV, both from Preloge.

The sources sometimes describe the bottom of the grave pit being covered by a thin layer of burnt remains, on top of which lay the skeleton.²⁰⁴ This is in all likelihood the rotten wooden bedding or remains of coffins, such as are known from graves at Stična and Novo mesto.²⁰⁵ Explicitly, Pečnik writes of coffins when describing Graves 2/h, 2/n and 2/13 from Preloge. The latter grave measured 4 x 2m, while the coffin was described thus, “[...] die Leiche in eine hölzerne Truge gelegt, aber nicht aus Laden, sondern aus dicken Holz, oder war mit Holztrüme gelegt [...]” Pečnik further writes of a knight and a horse lying in a thick coffin made of timbers.²⁰⁶ The coffin in Grave 13/136 must also have been well preserved for Brattina to be able to draw a sketch of it in his diary (fig. 30). Grave 2/n was reportedly also lined with large stones.

According to Goldberg, there was a stone heap in the centre of Tumulus VI at Preloge, which contained a grave (VI/12) in the centre. In some other cases, stones were set in corners of grave pits, but also used as stone bedding to lay the corpse onto and cover with gravel.²⁰⁷

On burial orientation and skeleton position

The descriptions of graves include rough determinations of skeleton orientation, though this information is not of much use without tumuli ground-plans. Noteworthy is that the largest number of graves dug by Pečnik (fig. 31) reportedly had either a NW–SE (52 cases) or a S–N (38 cases) orientation, while the orientations most frequently mentioned for the graves excavated by the Duchess of Mecklenburg (fig. 31) are either E–W (56 cases) and N–S (45 cases). These orientation patterns are markedly different and thus unreliable, making further analyses unreasonable. Nevertheless, the excavation data does not point to significant correlations between

²⁰⁴ Tecco Hvala/Dular/Kocuvan 2004, 182, no. 279.

²⁰⁵ Križ 1997, T. 4, 10, 19, 27, 49, 59, 66; *id.* 2000, T. 8, 11, 13, 18, 20, 22, 28, 30, 33–35, 40–42, 44. Gabrovec *et al.* 2006, Abb. 3–5, 12, 17–19, 27, 30, 33, T. 3, 37, 61, 70, 74, 75, 77, 97, 102.

²⁰⁶ Tecco Hvala/Dular/Kocuvan 2004, 35.

²⁰⁷ Lašič, *Gr. V/3; Preloge, Gr. IV/20, VI/8, VI/17, VI/37, VII/4; Ibid.*, 182, nos. 280–287.

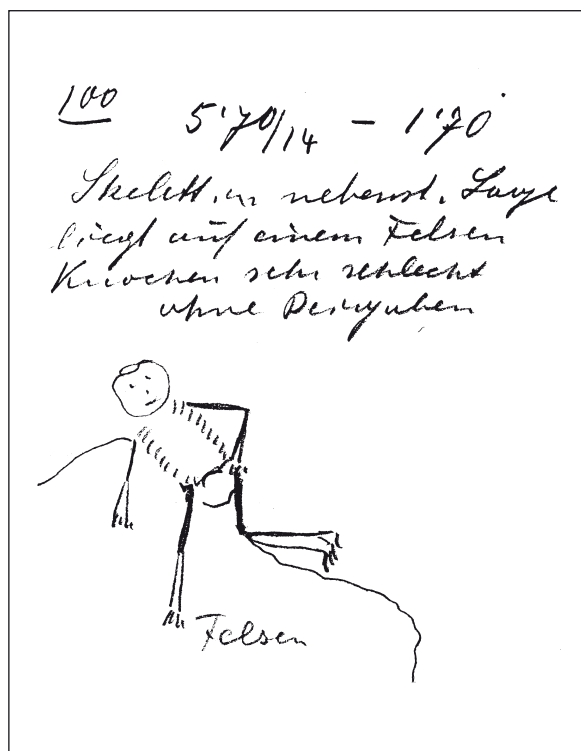

Sl. 32: Brattinova skica groba 13/100.

Fig. 32: Brattina's sketch of Grave 13/100.

napako pri opisovanju. Ob tem je nenavadno, da so taki pokopi zabeleženi le v gomili X na Prelogah.²¹⁰

3.2.3 SKUPNI POKOPI

On the structure of multiple burials

Dvojne pokope lahko na Magdalenski gori slutimo že med žganimi grobovi, kjer se omenjata dve žari s sežganimi kostmi.²¹¹ Tak primer predstavlja grob VII/7 s Prelog, o katerem obstaja tudi fotografija (sl. 18). Vseboval je dve večji in dve manjši posodi, v največji žari naj bi bili številni ženski pridatki (razlomljene zapestnice in nanožnice, stekleni jagodi, fibula sanguisuga, vijčki ter več nerazpoznavnih bronastih fragmentov). Razen tega se omenja še železna pasna spona, ki bi lahko bila moški atribut, vendar pa objavljeni primerek pozno-latenske okrogle spona vsekakor ni sočasen z ženskim okrasjem iz tega groba.²¹² Za dvojni pokop je morebiti šlo tudi v primeru groba 4/1 z Laščika, ki je vseboval moške in ženske pridatke v bronastem vedru. Moški je bil verjetno sežgan skupaj z opravo, sodeč po fragmentu

²¹⁰ Goldberg navaja smeri kot npr. J-SV: gr. X/29, X/34-35, X/69; JV-Z: gr. X/45, X/47; S-JV: gr. X/62; SV-Z: gr. X/65; V-S: gr. X/63; Z-JV: gr. X/42, X/44.

²¹¹ Laščik, gr. 1892/6; Preloge, gr. VI/23, VII/7.

²¹² Hencken 1978, 52, Fig. 225 in 226.

skeleton orientation and sex, age or status of the person interred.

Photographs and drawings of the excavations (figs. 34 and 37) clearly show that the deceased were laid in graves in an extended position on the back, with arms outstretched along the body.²⁰⁸ A minor exception to the rule was documented by Brattina in Grave 13/100 at Preloge (fig. 32), where a skeleton without grave goods lay within a tumulus on the bedrock, with left extremities slightly bent. This unusual position could be entirely coincidental, but it could represent either a semi-contracted position or a physical deformity.²⁰⁹ A deviation from the strictly straight-lined body position is discernible in five per cent of burials, though it is unclear whether these actually represent contracted burials or merely a description flaw. It is furthermore unusual that such burials were documented only in Tumulus X at Preloge.²¹⁰

3.2.3 MULTIPLE BURIALS

On the structure of multiple burials

Multiple burials might be seen in some cremation graves that contained two urns.²¹¹ One such example is Grave VII/7 at Preloge, which is even documented with a photograph (fig. 18). It contained two large and two small vessels; the largest urn reportedly contained numerous female grave goods (broken bracelets and anklets, two glass beads, a leech fibula, spindle whorls and several unidentifiable bronze fragments). Apart from that an iron belt clasp is also mentioned, which could be a male attribute, though the published example of a Late La Tène belt buckle is certainly not contemporary with the above-mentioned female attributes.²¹² Another multiple burial might be seen in Grave 4/1 at Laščik, which contained male and female attributes in a bronze bucket. Based on the fragment of a composite helmet with figural decoration, the male was presumably cremated in his costume, while the female jewellery – two-looped fibula of Type 6d after Gabrovec with solid bracelets hung as pendants – shows no traces of exposure to fire. This situation could be understood either as jewellery being offered to the deceased female after cremation or as a gift of a woman to the deceased male.

Among the inhumation burials of Magdalenska gora, multiple burials represent roughly three per cent

²⁰⁸ Hencken 1978, Figs. 242, 244, 271, 278, 289, 298, 309, 311, 316, 325, 340, 342, 356; Tecco Hvala/Dular/Kocuvan 2004, Abb. 31.

²⁰⁹ On unusual skeleton positions see Pauli 1975, 174 ff.

²¹⁰ Goldberg reported on orientations such as S-NE: Gr. X/29, X/34-35, X/69; SE-W: Gr. X/45, X/47; N-SE: Gr. X/62; NE-W: Gr. X/65; E-N: Gr. X/63; W-SE: Gr. X/42, X/44.

²¹¹ Laščik, Gr. 1892/6; Preloge, Gr. VI/23, VII/7.

²¹² Hencken 1978, 52, Figs. 225, 226.

Gom. / Gr. Tum. / Gr.																							
	Moški / Male	Ženski / Female	Otroški / Infant	Fibule / Fibulae	Uhani / Earrings	Ovratnice / Neckring	Steklene jagode / Glass beads	Jantar / Amber	Zapestnice / Bracelets	Nanožnice / Anklets	Pasne spone / Belts	Pasni okovi / Belt attachments	Čelada / Helmet	Sekire / Axes	Sulice / Spears	Noži / Knives	Meč / Sword	Žezlo / Mace	Brus / Whetstone	Konjska oprema / Horse gear	Lončenina / Pottery	Vijčki / Spindle whorls	Bronasto posodje / Bronze vessels
X/22	1	1		1				x	2														
13/114	1	1		2		1			2				1										
13/77	1	1				1	x	x	2	2	1												
VII/40	1	1?		9	4	6	x	x	4+1	28												5	
VIII/3	1	1?		1	2		x		2+2														
X/34-35	1+1?			1				x	2														
VIII/17-18	1+1?				1		x														1		
VIII/10-11	1+1?			2					1														
13/116	?	?		1																	3		
V/44-45	?	?																					
V/13-14	1	1						x	1						1								
13/55+57	1	1		2+2				x	2	1	x	1	1	1	1		1				1		2
X/32-33	2			2						1	x		1+1	2	1								
V/29	2						x			2	x	2		4+2		1		1	x				4
2/1-2?	2?	1?		6			x			1	x	1	3	4	1								
V/19-20	1+1?												1	2		1							

Sl. 33: Dvojni skeletni grobovi na Magdalenski gori.
Fig. 33: Double inhumation graves at Magdalenska gora.

figuralno okrašene sestavljene čelade, medtem ko na ženskem nakitu – dvoankasti fibuli tipa 6d po Gabrovcu z obešenima masivnima zapestnicama – ni opaziti, da bi bil izpostavljen ognju. To situacijo je moč razumeti na dva načina: da je bil nakit naknadno pridan sežgani sopotnici ali pa kot njen dar preminulemu.

Med skeletnimi grobovi je delež skupnih pokopov približno triodstoten (sl. 33). V zapiskih se večkrat omenja pokop odrasle osebe (ženske) z otrokom (sl. 6–8).²¹³ Tako je domneval Goldberg v primeru groba VII/40 s Prelog na podlagi majhne zapestnice in drobnih steklenih jagod, ki so ležale na kupčku pri pokojničinih nogah, čeprav o otroških kosteh ni bilo sledi. Otroške kosti naj bi po njegovem pričevanju našli v grobu V/2 na Laščiku, prav tako ob nogah pokojnice, a se je kasneje izkazalo, da gre pravzaprav za kosti srne.²¹⁴

Zabeleženi so tudi skupni grobovi dveh odraslih oseb različnega ali istega spola. Brattina je v pismu Szombathyju poslal skico groba 13/55 s Prelog, iz katere je razvidno, da je bila ob moškem pokopana ženska (sl. 34: A), vendar ju je evidencialno ločeno (ženski pokop

(fig. 33). The most frequently mentioned are burials of an adult (woman) and a child (figs. 6–8).²¹³ For Grave VII/40 at Preloge, for example, Goldberg supposed such a burial on the basis of a small bracelet and tiny glass beads lying at the feet of a female skeleton, though there were no traces of child's bones. Goldberg also wrote of child's bones in Grave V/2 from Laščik, at the feet of a deceased woman, though these turned out to belong to a roe deer.²¹⁴

Also documented are multiple burials of two adults of either the same or different sex. Brattina drew a sketch of Grave 13/55 at Preloge, which he sent in a letter to Szombathy; it clearly shows that a female was buried alongside a male with a unique helmet (fig. 34: A), though Brattina noted them as separate, the female in Grave 13/57. Another example is Grave V/13–14 in a tumulus at Laščik, where a male and a female were buried with heads towards the NE; the female had a tiny ribbed bracelet and amber beads, while the man had a knife with a bone handle.

²¹³ Preloge, gr. VII/40, VIII/3, X/22, 13/77, 13/114.

²¹⁴ Hencken je objavil risbo tega groba po fotografiji z izkopavanj, kosti srne pa je opredelil Bökönyi (Hencken 1978, 29, Fig. 102).

²¹³ Preloge, Gr. VII/40, VIII/3, X/22, 13/77, 13/114.

²¹⁴ Hencken published a drawing of this grave on the basis of a faded photograph, while the bones were attributed to the roe deer species by Bökönyi (Hencken 1978, 29, Fig. 102).

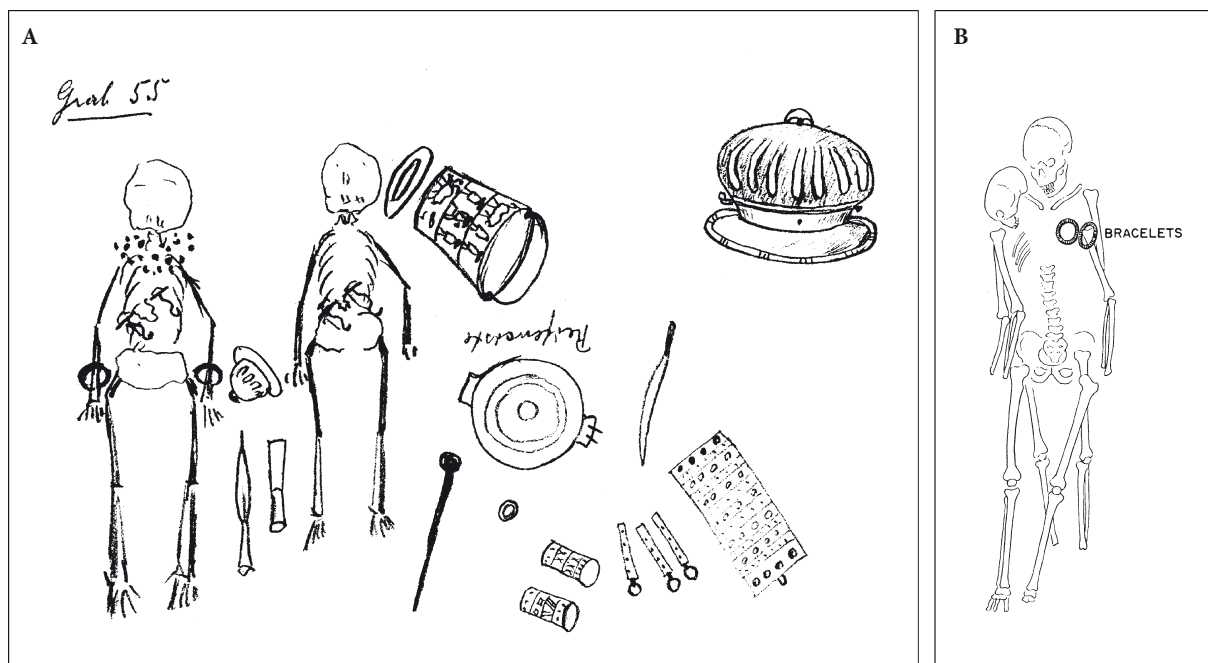

Sl. 34: A – Brattinova skica groba 13/55; B – risba groba X/34–35 po fotografiji z izkopavanj vojvodinje Mecklenburške (po Tecco Hvala/Dular/Kocuvan 2004, sl. 31 in po Hencknu 1978, Fig. 325).

Fig. 34: A – Brattina's sketch of Grave 13/55; B – drawing of Grave X/34–35 after the photo taken during the excavations by the Duchess of Mecklenburg (after Tecco Hvala/Dular/Kocuvan 2004, Abb. 31 and Hencken 1978, Fig. 325).

je označil kot grob 13/57). V grobu V/13–14 na Laščiku sta bila prav tako drug ob drugem pokopana moški in ženska z glavama proti SV; ženska je imela drobno nabrebreno zapestnico in jantarne jagode, moški pa železen nož s koščeno oblogo na držaju.

V nekaterih primerih spola pokojnih ni moč z gotovostjo ugotoviti, kot npr. v grobu 13/167 s Prelog, kjer Brattina omenja tri skelete brez pridatkov, ki da so ležali vsevprek, kot bi bili tja zmetani; ta grob je po rekonstruiranem tlorisu sodeč ležal na jugovzhodnem robu gomile. V grobu 13/116 iz iste gomile je bilo odkrito eno celo okostje in zraven še dve tibiji ter sledi drugih kosti, med pridatki pa se omenjajo posode in samostrelna fibula.²¹⁵ Nekaj takih pokopov je zabeležil tudi Goldberg. V gomili na Laščiku sta v grobu V/44–45 okostji ležali drugo vrh drugega in nista imeli nobenih pridatkov, po katerih bi lahko diagnosticirali spol in čas pokopa. V isti gomili so menda našli še tri skelete na kupu, dvema je bil pridan navaden lonec, tretji pa je bil oborožen s sulicama in nožem in je imel certoško fibulo.²¹⁶ Tudi v gomili VIII na Prelogah so naleteli na grobove z dvema okostjema; v grobu VIII/10–11 sta ležali drugo vrh drugega z glavama na vzhodu, vrhnje je imelo dve certoški fibuli in votlo zapestnico, spodnje

The preservation of some skeletons no longer allows their sex to be determined. Such is the case in Grave 13/167 from Preloge, for which Brattina mentions three skeletons without grave goods, reportedly lying in a haphazard manner as if thrown in; the reconstructed ground-plan of its tumulus puts it in the south-eastern edge. Grave 13/116 from the same tumulus revealed one complete skeleton and further two tibiae as well as traces of other bones, while grave goods consisted of pottery and a fibula with a crossbow spring.²¹⁵ Several such burials were also documented by Goldberg. In a tumulus at Laščik, for example, the two skeletons in Grave V/44–45 lay one on top of the other, without grave goods to help determine the sex or period of burial. The same tumulus reportedly revealed a heap of three skeletons, two with a simple jar, while the third one had a pair of spears, a knife, a Certosa fibula and other grave goods.²¹⁶ Tumulus VIII at Preloge also revealed graves with two skeletons, of which those in Grave VIII/10–11 lay one above the other with heads facing the east; the upper skeleton had a pair of Certosa fibulae and a hollow bracelet, while the bottom skeleton had no grave goods. According to Goldberg,

²¹⁵ Tecco Hvala/Dular/Kocuvan 2004, 70 s, 79, sl. 28 (rekonstruiran tloris gomile).

²¹⁶ Gre za grob V/23, ki ni bil vključen v Goldbergov numerični sistem, je pa o njem menda poročal v pismu vojvodinji; najdbe in skeleti so pogrešani: Hencken 1978, 34 in 41.

²¹⁵ Tecco Hvala/Dular/Kocuvan 2004, 70 f, 79, Abb. 28 (reconstructed ground-plan).

²¹⁶ It is Grave V/23, which Goldberg did not include into his numerical system, but mentioned it in his letter to the Duchess. The grave goods and skeletons are now missing: see Hencken 1978, 34 and 41.

pa je bilo brez pridatkov. Še en tak pokop (VIII/17–18) so odkrili na skrajnem severnem robu te gomile; eno okostje ni imelo ničesar, pri drugem so našli valjast uhan, modre steklene jagode in posodo. V grobu X/34–35 s Prelog pa sta bili pokopani domnevno dve odrasli ženski (tako je kostne ostanke opredelil Howells). Ležali sta druga vrh druge z glavama na SV (*sl. 34: B*), zgornja naj bi imela dve votli narokvici, kačasto fibulo in jantarne jagode, spodnja pa ničesar.²¹⁷

V nekaterih drugih primerih je razvidno, da sta bila skupaj pokopana dva moška. V grobu V/19–20 z Laščika sta okostji ležali v smeri sever–jug; med njima so bili položeni zgodnjelatenski meč, dve dolgi železni sulici in sekira z enostranskimi plavutmi. Težavneje je razvozlati situacijo v najprestižnejšem grobu iz iste gomile (V/29), čeprav obstajata o njem dve podrobni Goldbergovi poročili in fotografija. Vseboval naj bi ostanke dveh človeških okostij, ki se niso ohranili. Zraven so bili odkriti še konjski skeleti in veliko bogatih pridatkov, ki govorijo za čas zgodnje negovske stopnje. Hencken je na koncu opisa pripomnil, da so h grobni celoti pridani razni predmeti, ki jih Goldberg ne navaja.²¹⁸ Dvojni moški pokop je zabeležen tudi v gomili X na Prelogah. Grob X/32–33 je bil obkrožen s kamni, velikimi kot pest ali glava, pokojnika sta ležala z glavama na jugu; eden je imel par certoških fibul, predrto pasno spono, sekiro, dve dolgi sulični osti in nož, drugi pa le majhno sekiro.²¹⁹

Skupne pokope lahko slutimo še v nekaterih drugih primerih iz gomile X na Prelogah, kot bi lahko sodili po delno ohranjenem tlorisu gomile (*sl. 35*).²²⁰ Pokojnik X/2 je menda imel pasno spono, šilo, nož, posodo in valjaste uhanе, medtem ko je bilo zraven ležeče okostje brez pridatkov (X/3), po Angelovi oceni pa je šlo za mlado odraslo žensko. Drugi par predstavljata pokojnica X/13 z drobno narebreno zapestnico, jantarnimi jagodami in vijčkom in moški X/14, ki je imel sulico, nož, dve fibuli, predrto pasno spono in menda še en valjasti uhan. Na isti globini sta vzporedno ležali tudi okostji X/10 in X/16. Da je bila v grobu X/10 pokopana ženska, nakazujejo drobna narebrena zapestnica, jantarna ogrlica in par valjastih uhanov; drugo okostje (X/16) s podobnim valjastim uhanom in nožem je Angel opredelil za mlado odraslo žensko. Grobova X/21 in X/21a predstavljata vzporedna moška pokopa. Pokojnik X/21a je imel svinčeno narokvico, par velikih certoških fibul, vitko tulasto sekiro, dve dolgi sulici in nož s ploščatim nastavkom za

the northernmost edge of the tumulus revealed another such burial (VIII/17–18); one skeleton devoid of grave goods and the other with a cylindrical earring, blue glass beads and a ceramic vessel. Grave X/34–35 at Preloge reportedly contained two adult females (bone remains determined by Howells), lying one on top of the other with heads facing NE (*fig. 34: B*). The upper female had two hollow armlets, a serpentine fibula and amber beads, while the bottom one had nothing.²¹⁷

Apart from females, there are some graves where two males were buried together. In Grave V/19–20 at Lašič, for example, the skeletons were lying in a N–S direction with an Early La Tène sword, two long iron spears and a one-sided winged axe laid between them. More difficult to make out is the situation in the most prestigious grave of the tumulus, namely Grave V/29, for which two detailed reports by Goldberg and a photo exist. It reportedly contained the remains of two human skeletons, which are not preserved, but also horse skeletons and numerous rich grave goods pointing to the early Negova phase. Hencken added, at the end of his description of the grave, that the grave group included a number of objects not listed by Goldberg.²¹⁸ Another double male burial was documented in Tumulus X at Preloge, in Grave X/32–33. It was surrounded by stones, the size of a fist or a head, and the deceased were lying with their heads towards the south; one had a pair of Certosa fibulae, an openwork belt clasp, an axe, two long spearheads and a knife, while the other only had a small axe.²¹⁹

Multiple burials could possibly be seen in several other, originally separately marked graves in Tumulus X at Preloge, as suggested by the partially preserved ground-plan of the tumulus (*fig. 35*).²²⁰ The deceased male in Grave X/2, for example, reportedly had a belt clasp, awl, ceramic vessel and cylindrical earrings, while the skeleton beside it, identified by Angel as a young adult female, had no grave goods (Grave X/3). The second pair is represented by a female from Grave X/13 with a tiny ribbed bracelet, amber beads and a spindle whorl, and a male in Grave X/14 with a spear, knife, pair of fibulae, openwork belt clasp and reportedly also a cylindrical earring. Lying in the same depth and in parallel positions were skeletons in Graves X/10 and X/16. The former being a female is indicated by a tiny ribbed bracelet, an amber necklace and a pair of cylindrical earrings, while the latter had a similar cylindrical earring and a knife

²¹⁷ Hencken 1978, 41, 63, 64, 72, Fig. 284, 291, 325 in 326.

²¹⁸ *Ibid.*, 36 ss, Fig. 135–149. S primarnimi viri v zvezi s to grobno celoto se poglobljeno ukvarja Dragan Božič in o tem pripravlja objavo.

²¹⁹ Objavljena grobna celota ni povsem zanesljiva, saj vsebuje več predmetov, kot jih omenja Goldberg, kar se pogosto dogaja v primeru Mecklenburške zbirke, kot pripominja Hencken (1978, 71). Angel je enega izmed njih opredelil za moškega zrelih let z dinarsko mediteranskimi potezami.

²²⁰ *Preloge, gr. X/2+3; X/13+14; X/10+16, X/21+21a.*

²¹⁷ Hencken 1978, 41, 63, 64, 72, Figs. 284, 291, 325, 326.

²¹⁸ *Ibid.*, 36 ff, Figs. 135–149. The original documents of the grave group are to be examined closely by Dragan Božič with the intention of publishing his finding.

²¹⁹ The published grave group is not reliable; it includes a number of objects not listed by Goldberg, which is often the case with the Mecklenburg Collection, as noted by Hencken (1978, 71). One skeleton from this grave was determined by Angel as a mature man with Dinaric-Mediterranean traits.

²²⁰ *Preloge, Gr. X/2+3; X/13+14; X/10+16, X/21+21a.*

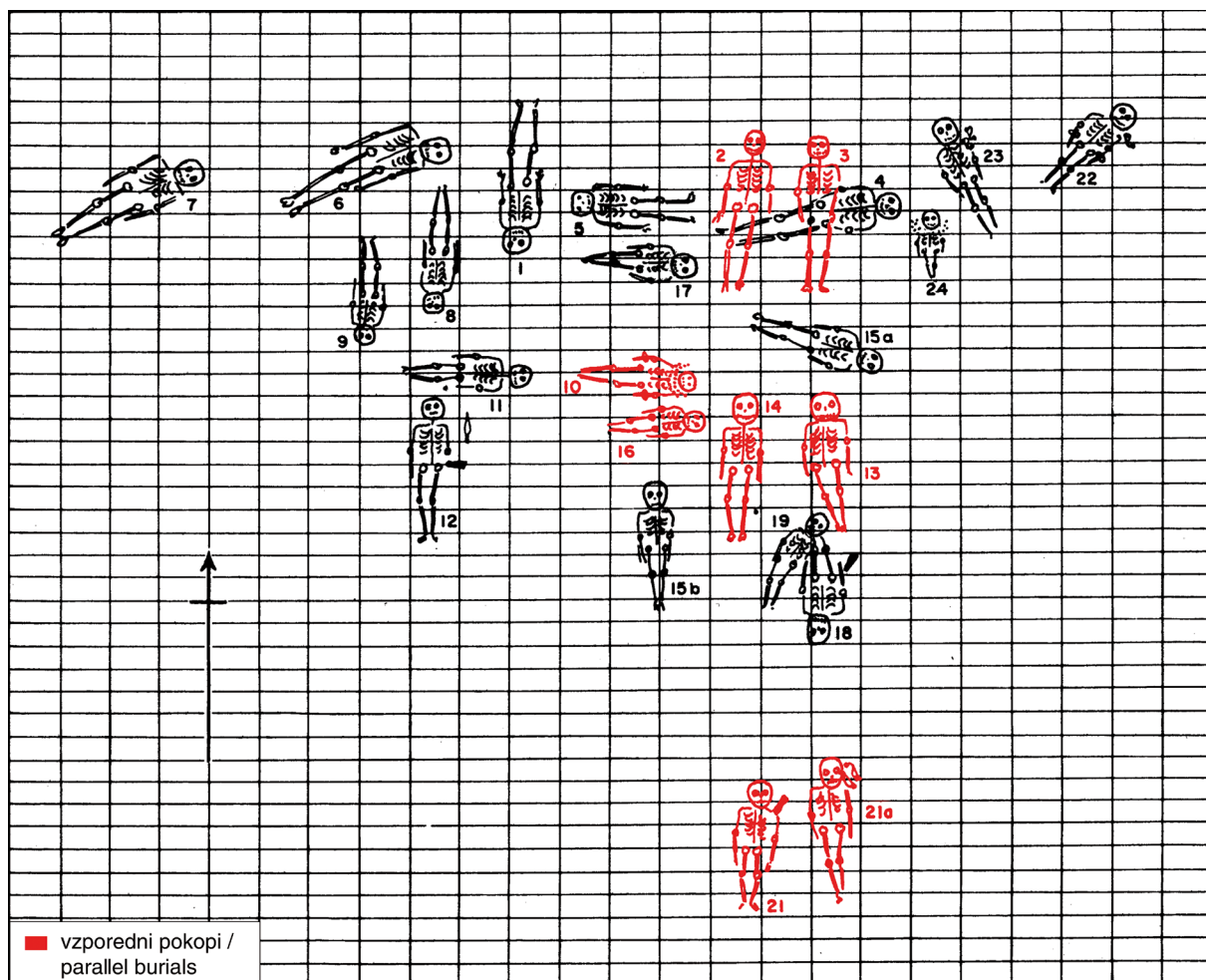

Sl. 35: Delni tloris gomile X na Prelogah z označenimi vzporednimi pokopi (po Hencknu 1978, Fig. 298).

Fig. 35: Partial ground-plan of Tumulus X at Preloge with marked parallel burials (after Hencken 1978, Fig. 298).

držaj, moški X/21 na njegovi desni pa je bil opremljen le s sekiro. Omenim naj še grob 2/1–2 s Prelog, ki je za-beležen edinole v inventarni knjigi dunajskega muzeja, saj o njem ni nobenih drugih poročil. To nezanesljivo grobno celoto sestavlja več garnitur orožja (4 sulice, 3 sekire, nož), negovska čelada, ki je izgubljena, ter trije pari fibul in nekaj temnomodrih steklenih jagod.

Kronološka slika skupnih pokopov

Žarna grobova VII/7 s Prelog in 4/1 z Laščika, ki sta dozdevno vsebovala ostanke več oseb, sta datirana v stopnjo Stična, enako kot skeletni grob VII/40, v katerem je bila pokopana vodilna predstavica tistega časa, domnevno skupaj z otrokom. Večina kronološko ali stratigrafsko zgovornih skupinskih pokopov pa spada v mlajše halštatsko obdobje – grob X/22 s Prelog v stopnjo kačastih fibul, preostali pa v čas certoških fibul ali negovskih čelad. Pri tem velja izpostaviti, da so pokopi dveh moških zastopani le v negovski stopnji.

and was identified by Angel as a young adult female. Graves X/21 and X/21a represent parallel male burials. The deceased in Grave X/21a had a lead armlet, a pair of Certosa fibulae, a slender socketed axe, two long spears and a knife with a flat tang, while the male to the right, in Grave X/21, only had an axe. Further to be mentioned is Grave 2/1–2 at Preloge, which is documented only in the inventory book at the museum in Vienna. This unreliable grave group consists of several sets of weapons (4 spears, 3 axes, knife), a Negova helmet, now lost, three pairs of fibulae and several dark blue glass beads.

Chronological determination of multiple burials

The urn Graves VII/7 at Preloge and 4/1 at Laščik, supposedly containing remains of several individuals, date to the Stična phase, the same as inhumation Grave VII/40 with the burial of a leading representative of that period, supposedly together with a child. Apart from those, most of the chronologically and stratigraphically

Ozrmo se še po drugih najdiščih dolenjskega halštatskega kroga.²²¹ Med starejše dvojne pokope spada grob 139/6 na Budinjaku iz časa stopnje Podzemelj 2, v katerem je bil pokopan poglavar s skledasto čelado in na njegovi levi ženska.²²² Iz časa stopnje Stična 2 je zabeležen grob ženske z otrokom v Stični,²²³ iz certoške stopnje pa skupni pokop moškega in ženske v Vintarjevcu in Suhadolah.²²⁴ Najbolj slovita sta dvojna grobova iz Novega mesta, datirana v negovsko stopnjo; v enem je bil pokopan poglavar z negovsko čelado skupaj z bogato opravljeno žensko (Znančeve njive, gr. 4/3), v drugem dva bojovníka z ilirskima čeladama (Kapiteljska njiva, gr. 7/19).²²⁵ Znamenit je tudi pokop poglavarja skupaj z žensko iz Dolenjskih Toplic (5/17), medtem ko je bil drug tak grob (2/35) skromnejši – eno okostje ni imelo pridakov, pri drugem so našli sulični osti, tulasto sekiro in dve fibuli.²²⁶ V Brezju pri Trebelnem pa se omenja dvojni skeletni grob brez pridakov.²²⁷

V starejši železni dobi so skupni skeletni grobovi izpričani tudi na Balkanu. Naj se dotaknem le skupnosti v Donji Dolini, ki je imela stike s takratnimi prebivalci Dolenjske, kar potrjujejo mnoge paralele v predmetih. Na tamkajšnjih grobiščih so opisani primeri, ko je v grobni jami ležalo žensko okostje nad moškim ali je bila ob ženski pokopana še druga ženska ali odrasla oseba brez pridakov. V nekaterih grobovih je bil z odraslo osebo pokopan otrok ali pa je bilo v eni jami več skeletov brez pridakov. Na splošno gre za grobove iz mlajših faz starejše železne dobe.²²⁸

Na drugi strani so mnogi skupinski grobovi poznani iz poznohalštatskega in zgodnjelatenskega obdobja v Hallstattu ter na drugih najdiščih v srednjeevropskem prostoru.²²⁹ Prav tako se pojavljajo v Picenumu, kjer je v železni dobi prevladoval skeletni pokop bodisi v gomile bodisi znotraj grobnih parcel. V grobiščih Novilare so iz časa od 8. do 6. st. pr. n. št. zabeleženi pokopi moškega in ženske ali dveh moških (očeta? in sina), dveh bratov

telling multiple burials date to the Late Hallstatt period – Grave X/22 at Preloge to the Serpentine Fibulae phase and the others in either the Certosa or the Negova phase. Noteworthy on that subject is that the burials of two males only date to the Negova phase.

The Dolenjska Hallstatt circle revealed other cemeteries with multiple burials besides Magdalenska gora.²²¹ At Budinjak, one of the early multiple burials is in Grave 139/6 dated to the Podzemelj 2 phase, where a chieftain with a bowl-shaped helmet was buried and on his left a female.²²² From the Stična 2 phase a grave of a woman with a child is known at Stična,²²³ while from the Certosa phase burials of a male and a female were documented at Vintarjevec and Suhadole.²²⁴ The most famous multiple burials from Novo mesto date to the Negova phase; one of a chieftain with a Negova helmet, buried with a richly adorned female (Znančeve njive, Gr. 4/3), while the other revealed two warriors with Illyrian helmets (Kapiteljska njiva, Gr. 7/19).²²⁵ Also well known is the burial of a chieftain and a female from Dolenjske Toplice (Gr. 5/17), while another such grave (Gr. 2/35) was less rich – one skeleton without grave goods and the other with two spearheads, a socketed axe and two fibulae.²²⁶ Another multiple burial without grave goods is mentioned at Brezje pri Trebelnem.²²⁷

Multiple inhumation burials from the Early Iron Age are also known in the communities in the Balkans. One of them was at Donja Dolina, which had ties with the inhabitants of Dolenjska, as evidenced by numerous similar objects. The cemeteries of the said community revealed burials of a female on top of a male in the same grave pit, or a female and another female or adult individual without grave goods. Some of the graves even revealed a child buried alongside the adult, or several skeletons buried together without grave goods. In general, these graves date to the late phases of the Early Iron Age.²²⁸

Numerous multiple burials are further known from the Late Hallstatt or Early La Tène periods at Hallstatt and other central European sites.²²⁹ They also appear in

²²¹ Glej Kruh 2008, 75 ss.

²²² *Budinjak*, gr. 139/6: Škoberne 1999, 54 ss, sl. 46.

²²³ *Stična*, gr. 48/87–87A: Gabrovec et al. 2006, 68 ss, T. 51–52.

²²⁴ *Suhadole*, gr. 3: Dular J. 2003, 270, T. 90; *Vintarjevec*: Stare F. 1953, 264 ss, T. I–VI.

²²⁵ *Novo mesto-Znančeve njive*, gr. 4/3: Knez 1986, T. 30–37, 66–69, 74–77; *Novo mesto-Kapiteljska njiva*, gr. 1/19, 3/21, 7/19: Knez 1993, T. 22; Križ 1997, T. 48; Egg 1999.

²²⁶ *Dolenjske Toplice*, gr. 2/35, 5/17: Teržan 1976, 398 s, 401, T. 16 in 29–31.

²²⁷ *Brezje*, gr. 1/63: Kromer 1959a, 56.

²²⁸ *M. Petrović jr.*, gr. 1, 11, 12, 35, 47, 61, 62; *S. Jakarić*, gr. 18–19; *I. Stipančević*, gr. 13; *N. Šokić I*, gr. 4; *N. Šokić II*, gr. 12: Truhelka 1904; Čović 1987, 272.

²²⁹ Pauli 1978, 54 ss; Lorenz 1980, 144; Zeller 1980, 174 ss, Abb. 1, 3, 31; Hodson 1990, 17 s, 84 s, 89, 98, Pl. 55–57, 63, 71; Egg 1999, 344 ss.

²²¹ See Kruh 2008, 75 ff.

²²² *Budinjak*, Gr. 139/6: Škoberne 1999, 54 ff, fig. 46.

²²³ *Stična*, Gr. 48/87–87A: Gabrovec et al. 2006, 68 ff, T. 51–52.

²²⁴ *Suhadole*, Gr. 3: Dular J. 2003, 270, T. 90; *Vintarjevec*: Stare F. 1953, 264 ff, T. I–VI.

²²⁵ *Novo mesto-Znančeve njive*, Gr. 4/3: Knez 1986, T. 30–37, 66–69, 74–77; *Novo mesto-Kapiteljska njiva*, Gr. 1/19, 3/21, 7/19: Knez 1993, T. 22; Križ 1997, T. 48; Egg 1999.

²²⁶ *Dolenjske Toplice*, Gr. 2/35, 5/17: Teržan 1976, 398 f, 401, T. 16, 29–31.

²²⁷ *Brezje*, Gr. 1/63: Kromer 1959a, 17.

²²⁸ *M. Petrović Jr.*, Gr. 1, 11, 12, 35, 47, 61, 62; *S. Jakarić*, Gr. 18–19; *I. Stipančević*, Gr. 13; *N. Šokić I*, Gr. 4; *N. Šokić II*, Gr. 12: Truhelka 1904; Čović 1987, 272.

²²⁹ Pauli 1978, 54 ff; Lorenz 1980, 144; Zeller 1980, 174 ff, Abb. 1, 3, 31; Hodson 1990, 17 f, 84 f, 89, 98, Pl. 55–57, 63, 71; Egg 1999, 344 ff.

ali vojnih pobratimov, poglavarja in oprode.²³⁰ Fenomen skupnih pokopov torej ni vezan na določeno kulturno sredino niti na ožje časovno obdobje.

Poskus razlage skupnih pokopov

Za razlago skupnih pokopov bi bile moderne antropološke analize zelo dragocene, saj bi lahko odločilno prispevale ne le k ugotavljanju spola in starosti pokojnih, temveč tudi o njihovih morebitnih sorodstvenih zvezah in vzrokih za smrt, vendar jih žal nimamo, zato se moramo zadovoljiti z bolj ali manj zgovornimi konteksti. Večje in manjše okostje v grobu si intuitivno lahko razlagamo kot pokop matere z otrokom; tudi v skupnem pokopu moškega in ženske bi lahko videli družinsko celico oz. zakonski par. Manj samoumevni so pokopi dveh odraslih moških ali dveh odraslih žensk skupaj. Čeprav pokop dveh žensk v grobu X/34–35 s Prelog ni podkrepjen s pridatki, pa te možnosti ne gre povsem izključiti. Taka primera sta poznana iz Hallstatta v grobovih 183–184 in 376, kjer sta bili pokopani pokojnici, držoč se pod roko.²³¹

Še bolj zagonetni so razlogi za take pokope, o čemer so že mnogi razpravljali.²³² Ali je šlo za žrtvovanje ali za sukcesivno pokopavanje v isto grobno jamo, morda za brate v krvi in orožju, ali kaj drugega? V nekaterih študijah je nakazana možnost človeškega žrtvovanja, npr. ženske za spremstvo poglavarju v onostranstvo.²³³ Tak primer je izpričan v zgodnji negovski stopnji na dveh sosednjih najdiščih ob Krki, kjer sta bila najvidnejša predstavnika novomeške in topliške srenje pokopana po natanko enakem pogrebnem ceremonialu.²³⁴ Na Magdalenski gori bi tak obred lahko videli kvečjemu v primeru groba 13/55 in 13/57 s Prelog (*sl. 34: A*) iz časa stopnje certoških fibul, vendar o grobni jami ni podatkov, zato ni jasno, ali je šlo za skupni ali za ločena grobova. V večini drugih primerov so bolj verjetni drugačni razlogi, saj so bile nekatere družno pokopane osebe precej skromno opravljene²³⁵ in ne kažejo znakov kakega posebnega položaja v družbi. Okostja so ponekod ležala drugo vrh drugega,²³⁶ kar bi si lahko razlagali kot naknadni pokop v isto grobno jamo. Motivi za skupne pokope in vzroki sočasne smrti so zagotovo lahko zelo različni –

²³⁰ Molaroni, *gr. 31–31a, 130–131; Servici, gr. 26, 57a–57b, 59–60, 70*; Beinhauer 1985, 31 ss.

²³¹ Hodson 1990, Pl. 56 in 63.

²³² Pauli 1978, 57 ss; Egg 1999, 344 ss.

²³³ Oeftiger 1984; Teržan 1990a, 94, 131, 134, 147, 165, 173; ead. 1997, 663 ss; id. 2008, 226 ss; Tomedi 2002, 289 s; Gabrovec et al. 2006, 268.

²³⁴ *Novo mesto-Znančeve njive, gr. 4/3*: Knez 1986, T. 30–37; *Dolenjske Toplice, gr. 5/17*: Teržan 1976, 385 ss, T. 29–31.

²³⁵ Glej npr. *Magdalenska gora: Laščik, gr. V/13–14, V/44–45; Preloge, gr. 13/116*.

²³⁶ Glej npr. *Magdalenska gora: Laščik, gr. V/44–45; Preloge, gr. VIII/10–11, X/34–35*.

Picenum, where inhumation burial in tumuli or within burial plots was the predominant rite in the Early Iron Age. The cemeteries of Novilara, where burial took place from the eighth to the sixth century BC, revealed graves of a male and a female or two males (father and son, two brothers or brothers in arms, chieftain and attendant?).²³⁰ The above clearly shows that the phenomenon of multiple burials is not linked to a specific cultural milieu nor to a particular time period.

Attempt at an interpretation of multiple burials

The interpretation of multiple burials would greatly benefit from modern anthropological analyses, both in determining sex and age of the deceased and in revealing possible family ties, pathologies and causes of death. In the absence of such analyses, we must do with more or less revealing contexts. A large and a small skeleton found together in a grave are intuitively interpreted as a burial of mother and child; the common burial of male and female could also be seen to reveal a family unit or couple. Less obvious are burials of two adult males or females. As for two females, such a burial could be seen in Grave X/34–35 at Preloge, though this is not corroborated by grave goods. Two such examples are known at Hallstatt, in Graves 183–184 and 376, where the females were buried holding hands.²³¹

Even less obvious are reasons behind such burials, discussed already by numerous authors.²³² Was it a sacrifice, successive burial into the same grave pit, blood brothers, brothers in arms or something else entirely? Some studies indicate possible human sacrifice, such as a female sacrificed to accompany the chieftain into the afterlife.²³³ Such cases were attested to for the early Neogova phase on two nearby sites along the River Krka,²³⁴ where two of the most prominent representatives of the local communities were buried according to the exact same ceremony. At Magdalenska gora, such a ceremony could possibly be seen only in Graves 13/55 and 13/57 at Preloge (*fig. 34: A*) from the Certosa phase; in the absence of data on the grave pit, however, it is unclear whether it was one multiple or two separate burials. In most other graves other reasons are more plausible, since they do not show signs of an exceptional position in society.²³⁵ Skel-

²³⁰ Molaroni, *Gr. 31–31a, 130–131 and Servici, Gr. 26, 57a–57b, 59–60, 70*; Beinhauer 1985, 31 ff.

²³¹ Hodson 1990, Pl. 56 and 63.

²³² Pauli 1978, 57 ff; Egg 1999, 344 ff.

²³³ Oeftiger 1984; Teržan 1990a, 94, 131, 134, 147, 165, 173; ead. 1997, 663 ff; ead. 2008, 226 ff; Tomedi 2002, 289 f; Gabrovec et al. 2006, 268.

²³⁴ *Novo mesto-Znančeve njive, Gr. 4/3*: Knez 1986, T. 30–37; *Dolenjske Toplice, Gr. 5/17*: Teržan 1976, 438 ff, T. 29–31.

²³⁵ For example *Magdalenska gora: Laščik, Gr. V/13–14, V/44–45; Preloge, Gr. 13/116*.

razen ritualnih žrtvovanj bi lahko prišle v poštev tudi smrtonosne nalezljive bolezni, bojno tovarštvo oz. pobratimstvo, poboji, kaznovanje s smrtjo itd. Toda ta vprašanja bi si lahko resneje zastavili šele ob mnogo bolj reprezentativnem antropološkem vzorcu in analizah, kot pa jih premoremo za dolensko halštatsko skupnost.

3.2.4 ŽIVALSKI OSTANKI V GROBNEM KULTU

Pokopi konjev (*sl. 12: B*) in v grobovih najdene posamezne živalske kosti ali zobje (*sl. 36*) imajo zagotovo simbolni pomen. Največ konjskih skeletov na vsem jugovzhodnoalpskem prostoru je bilo odkritih v magdalenskogorskih gomilah, o čemer je pisal že Dular, zato na tem mestu povzemam njegove ugotovitve.²³⁷

Po pridatkih lahko pokope konj na Magdalenski gori datiramo v mladohalštatski čas. Bökönyi jih uvršča v vzhodno skupino jezdnih konjev, ki sta jih odlikovali eleganca in hitrost, v nasprotju z domačimi delovnimi konji, ki so dokumentirani npr. v stiški naselbini.²³⁸ Bolj ali manj cela konjska okostja so našli v grobovih konjenikov, ob njih ali nad njimi (*sl. 36*).²³⁹ Da so konjeniki spadali v sam vrh vojaške hierarhije, dokazujejo tudi poglavarске insignije (čelada, meč, žezlo, raženj) ter ceremonialno posodje oz. dragoceni bronasti servisi (situle, bronaste zajemalke, ciste). Ob konju, ki je bil prav tako slavnostno opravljen z bogato okrašenim jermenjem in žvalami, je bil večkrat najden še bronast kotliček. Ta tesna zveza iskrih konjev s poglavarji dolenske halštatske skupnosti kaže na to, da so predstavljali prestiž oz. predvsem statusni označevalec.²⁴⁰

Drugačno sporočilo se skriva v posameznih živalskih zobeh, kremplju, roževinastih delih, ki so jih nosili nekateri moški iz magdalenskogorske skupnosti kot obeske okoli vratu. To dokazuje njihova lega na okostju, saj so bili običajno najdeni na prsnem košu in preluknjani. V moških grobovih zasledimo po en ali več konjskih zob, kozji rog in medvedji kremplj,²⁴¹ medtem ko je bil pasji zob najden tako v moškem (Preloge, gr. VII/51) kot tudi v ženskem grobu (Preloge, gr. 13/87). Ti predmeti so verjetno predstavljali amulete.

Razen zob, krempljev in delov rogovja so v nekaterih grobovih zabeležene tudi posamične živalske kosti – v moških grobovih astragalne kosti in skočnici goveda in kosti domačega prašiča, v ženskih pa metatarzalne kosti srne, srnina lobanja in konjska tibija, pa tudi vretence

etons were sometimes lying one above the other,²³⁶ which might be seen as subsequent burial into the same grave pit. Motives for multiple burials and causes of simultaneous deaths could be various – apart from ritual sacrifice also contagious diseases, brothers-in-arms, massacres, as well as executions or death punishments and others. Such questions can be addressed only when dealing with a more representative anthropological sample and analyses than that available for the Dolenska community.

3.2.4 ANIMAL REMAINS IN THE FUNERARY CULT

Burials of horses (*fig. 12: B*) and individual animal bones or teeth found in graves (*fig. 36*) certainly have a symbolic significance. The largest number of horse skeletons in the south-eastern Alpine area was found in the tumuli of Magdalenska gora; they were written about already by Janez Dular, whose findings are summarized below.²³⁷

Horse burials at Magdalenska gora may be dated, on the basis of grave goods, to the Late Hallstatt period. Bökönyi classified these animals in the eastern group of riding horses, distinguished by their elegance and speed, in contrast to domestic working horses documented, for example, in the settlement at Stična.²³⁸ More or less complete horse skeletons were found beside or above the graves of horsemen (*fig. 36*),²³⁹ who were at the very top of military hierarchy as evidenced by chieftain's insignia (helmet, sword, mace, spit) and ceremonial vessels or valuable bronze sets (situlae, bronze ladle, cists). Alongside several horses, also ceremoniously adorned with decorated straps and bridle, a bronze cauldron was found. This close connection between fast horses and chieftains of the Dolenska Hallstatt community points to the former representing an object of prestige and a status symbol.²⁴⁰

The message behind individual animal teeth, claws, horn parts, which some males of the Magdalenska gora wore as pendants around their necks, is quite different. Such use is indicated by their perforation and position on the skeletons, usually on the chest. Male graves revealed one or more horse teeth, a goat horn and a bear claw,²⁴¹ while a dog tooth was found in both male (Preloge, Gr. VII/51) and female graves (Preloge, Gr. 13/87). These objects most likely represented amulets.

²³⁶ For example *Magdalenska gora: Laščik, Gr. V/44–45; Preloge, Gr. VIII/10–11, X/34–35.*

²³⁷ Dular J. 2007b.

²³⁸ See here Chapter 1.1.3 and Bökönyi 1994.

²³⁹ *Laščik, Gr. V/6–7a–7, V/29; Preloge, Gr. IV/43, 2/13, 2/57, 13/119.*

²⁴⁰ Teržan 2008, 238 ff, Abb. 34, 35, 62; *ead.* 2011b.

²⁴¹ *Laščik, Gr. V/5, V/11; Preloge, Gr. X/14, X/18, X/28, 2/69, 13/132.*

²³⁷ Dular J. 2007b.

²³⁸ Glej tu poglavje 1.1.3 in Bökönyi 1994.

²³⁹ *Laščik, gr. V/6–7a–7, V/29; Preloge, gr. IV/43, 2/13, 2/57, 13/119.*

²⁴⁰ Teržan 2008, 238 ss, sl. 34, 35 in 62; *ead.* 2011b.

²⁴¹ *Laščik, gr. V/5, V/11; Preloge, gr. X/14, X/18, X/28, 2/69, 13/132.*

Gom. / Gr. Tum. / Gr.	Živalska vrsta Animal species	Celo okostje / Complete skeleton	Posamezne kosti / Individual bones	Zobje / Teeth	Fibule / Fibulae	Uhani / Earrings	Steklene jagode / Glass beads	Jantar / Amber	Zapestnice / Bracelets	Nanožnice / Anklets	Pasne sponje / Belts	Čelada / Helmet	Sekire / Axes	Sulice / Spears	Puščice / Arrows	Noži / Knives	Meč / Sword	Žezlo / Mace	Raženj / Spit	Dereze / Crampons	Brus / Whetstone	Konjska oprema / Horse gear	Lončenina / Pottery	Bronasto posodje / Bronze vessels
2/13	Konj/Horse	1									2	1	1	2	x			1		2		x		4
V/6-7	Konj/Horse	1			2						2	1		4		1			2			x		3
2/57	Konj/Horse	1			2						2	1	1	2		1						x	4	
13/119	Konj/Horse	1									1	1	1	2		2						x	2	1
V/29	Konj/Horse	2	2x				x				2	2		6			1				1	x		4
IV/43	Konj/Horse Bik/Bull	1	x		2?								2?	2?	?	1?		1?		2?		?	2	
IV/30	Konj/Horse?		?																			x	1	
IV/32	Konj/Horse		x		2						1	1		1		1						x	1	2
IV/40	Konj/Horse		x					2																
V/5	Konj/Horse		x	2	1?						1			1		1						x		
VII/39	Konj/Horse		x	x	1						1	1	1	2		1						x		
2/69	?		x		2								1	1		2								1
X/14	Konj/Horse		1		2	2					1			1		1								
X/28	Konj/Horse		1											2										
2/88	Konj/Horse		x																					1
X/18	Konj/Horse Ovca-koza Sheep-Goat		1	1	1								1	1										
13/132	Koza/Goat		rog horn		1								1	2		1								
X/52	Prašič/Pig		x								1		1	1		1								1
V/11	Medved/Bear		krem- pelj claw		1						1		1	2		1								1
VII/51	Pes-volk Dog-wolf		1								1					1								
13/87	Pes/Dog		1		1	x	x	x	2															
VII/38	Konj/Horse Srna/Deer		1 1		1			x	2															
V/2	Srna/Deer		x		3	x	x	x	3															
II/17	?		rog horn			x	x		2									1						
13/163	Ovca-koza Sheep-Goat		x		3		x	x	10	24														4
VII/29	Ovca-koza Sheep-Goat		1		1																			

Sl. 36: Grobovi na Magdalenski gori z živalskimi okostji, posameznimi kostmi ali zobmi.

Fig. 36: Graves at Magdalenska gora with animal skeletons, individual bones or teeth.

ovce ali koze.²⁴² Goldberg navaja, da sta bila pokojnici v grobu II/17 s Prelog pridana dva obdelana kosa rogovja. Po pričevanju Brattine so bile ovčje ali kozje koščice najdene tudi v žarnem grobu 13/163 s Prelog. V njegovem dnevniku lahko preberemo, da niso bile sežgane: “*Der Leichenbrand liegt neben der zerdrückten Urne, wenig davon in der Urne, dagegen unverb. Knochen v einem Schafe od eine Z. in der Urne.*” Na spletni strani Peabodyjevega muzeja je v sklopu najdb z Magdalenske gore v Mecklenburški zbirki objavljena tudi fotografija obeska s kavri polžem,²⁴³ ki ga Hencken ni vključil v svojo objavo; kljub nezanesljivi provenienci pa je v zvezi s to temo umestno nanj opozoriti. Na osnovi teh podatkov bi lahko sklepali, da ni šlo za prilaganje mesne hrane umrlim za popotnico v onostranstvo ali prinašanje obeda na grob, kot je bila navada pri nekaterih drugih železnodobnih skupnostih.²⁴⁴

Bežen pregled živalskih ostankov v grobiščih na območju dolenske halštatske skupnosti razkriva kar nekaj pokopov konjev ter konjski kosti in zob v grobovih.²⁴⁵ V Podzemlju so odkrili tudi okostje velikega psa,²⁴⁶ v okolici Velikega Vinjega vrha (Šmarjete) so v gomili II/1880 na Lazah našli čeljust volka (?) in konjske kosti, v gomili 7/1901 v Gradenjski hosti pa menda živalsko kost v skledi, ki je spadala med pridatke bogatega moškega groba (omenjam ga v zvezi z žganim pokopom v kamnito skrinjo).²⁴⁷ Znani sta tudi najdbi pravih kavri polžev z Vintarjevca in Vač²⁴⁸ ter njihovih posnetkov v bronasti izvedbi.²⁴⁹

Drugačen grobni ritual nakazujejo ostanki živali, zabeleženi na blejski Pristavi v planem grobišču z žganimi pokopi iz starejše železne dobe. Kot je ugotovil Gabrovec, se pojavljajo samo v skupini grobov brez žare, ki so imeli nepravilen pravokotni tloris in so bili prekriti s plastjo kamenja. Živalske kosti in zobje so bili najdeni na kamniti groblji in deloma v njej, kar po njegovem mnenju kaže na obred prinašanja jedi na grob. Med njimi je bilo največ govejih nožnih kosti, nekaj ovčjih oz. kozjih koščic in zob, tu in tam sta se našla kakšna prašičja kost in pasji podočnik. Za razliko od dolenskih grobov, kjer se posamične kosti in zobje pojavljajo v grobovih in ne na njih, na Bledu tudi ni bilo zabeleženih jelenjih ali srninah ostankov. Odkrit pa je bil pasji ali volčji skelet, obdan s kamni. Ker se je

²⁴² Laščik, gr. V/2; Preloge, gr. IV/43, VII/29, VII/38, X/52. Glej tu poglavje 1.1.3 in sl. 3.

²⁴³ <http://www.peabody.harvard.edu/node/39>. Napredno iskanje po zbirkah: Duchess of Mecklenburg Collection of Iron Age artifacts and osteological material from Slovenia: Peabody ID #: 34-25-40/9339.

²⁴⁴ Stadler 2010.

²⁴⁵ Dular J. 2007b.

²⁴⁶ Podzemelj-Škrilje, gr. 1/13: Barth 1969, 149.

²⁴⁷ Dular A. 1991, 37, 40 s, 45.

²⁴⁸ Stare F. 1953, T. 2: 3; id. 1955a, T. 58: 1,2.

²⁴⁹ Grahek 2004, 152 ss, sl. 42.

Apart from teeth, claws and horns, some graves also revealed individual animal bones – in male graves cattle astragali and two tali as well as bones of a domestic pig, while the female graves revealed metatarsal bones of a roe deer, a roe deer skull, a horse tibia and a caprovid vertebra.²⁴² Goldberg mentions that the deceased woman in Grave II/17 from Preloge had, among other goods, two worked pieces of horn. According to Brattina, small caprovid bones were found in urn Grave 13/163 at Preloge; he stated in his diary that they had not been cremated, “*Der Leichenbrand liegt neben der zerdrückten Urne, wenig davon in der Urne, dagegen unverb. Knochen v einem Schafe od eine Z. in der Urne.*” Furthermore, the website of the Peabody Museum includes a photograph of a pendant with a cowrie shell apparently from Magdalenska gora,²⁴³ Hencken, however, did not include it in his publication, which makes its provenance uncertain. On the basis of all this data, it is possible to conclude that the inhabitants of Magdalenska gora did not provide the deceased with food for after-life or bring meat meals at their graves, as was the case in some other Iron Age communities.²⁴⁴

A brief overview of the animal remains in the cemeteries of Dolenjska reveals several horse burials and horse bones or teeth.²⁴⁵ Apart from these, a skeleton of a big dog was found at Podzemelj.²⁴⁶ Near Veliki Vinji vrh (Šmarjeta), a jaw of a wolf (?) and horse bones were found in Tumulus II/1880 at Laze, while in Tumulus 7/1901 at Gradenjska hosta an animal bone was reportedly found in a bowl, which was one of the grave goods in a rich male grave (mentioned above as a cremation burial in a cist).²⁴⁷ Also known are two finds of cowrie shells at Vintarjevec and Vače, respectively,²⁴⁸ and their imitations in bronze.²⁴⁹

A different funerary ritual is discernible from the animal remains documented at Pristava in Bled, in a flat cemetery with cremation burials from the Early Iron Age. As observed by Gabrovec, they appeared only in a group of graves without an urn, with an irregular rectangular ground-plan and covered by a layer of stones. Animal bones and teeth were found within and on top of the stone layer, which in Gabrovec's opinion points to a ritual offering of food at the grave. The animal remains are mostly represented by cattle leg bones, several caprovid bones and teeth, some pig bones and a dog's

²⁴² Laščik, Gr. V/2; Preloge, Gr. IV/43, VII/29, VII/38, X/52. See here Chapter 1.1.3 and fig. 3.

²⁴³ <http://www.peabody.harvard.edu/node/39>. Advanced search in Collections: Duchess of Mecklenburg Collection of Iron Age artifacts and osteological material from Slovenia: Peabody ID #: 34-25-40/9339.

²⁴⁴ Stadler 2010.

²⁴⁵ Dular J. 2007b.

²⁴⁶ Podzemelj-Škrilje, Gr. 1/13: Barth 1969, 149.

²⁴⁷ Dular A. 1991, 37, 40 f, 45.

²⁴⁸ Stare F. 1953, T. 2: 3; id. 1955a, T. 58: 1,2.

²⁴⁹ Grahek 2004, 178 f, fig. 42.

na lokaciji prazgodovinske nekropole razprostiralo tudi staroslovansko grobišče, ni povsem jasno, ali je spadal pasji oz. volčji grob v kontekst prazgodovinskega ali zgodnjeresnoveškega grobišča.²⁵⁰

V vodilni nekropoli svetolucijske skupine se v nekaterih grobovih omenjajo rebra in zobovje goved ter kozje koščice.²⁵¹ Zagotovo je na območju jugovzhodnih Alp tovrstnih materialnih pričevanj še precej več, toda gradivo ni sistematično zbrano in analizirano, ki bi pokazalo, katere živalske vrste in kateri deli živali so kje zastopani. Nedvomno pa so živalski ostanki v opisanih kontekstih del obredja, povezanega bodisi z grobnim kultom bodisi s čaščenjem boginje živali ali z magijo oz. varovanjem pred zlimi silami.

Na območju zahodne Panonije so živali v grobnem kultu obilno zastopane. V Porabju se v grobovih največkrat pojavlja svinja. Teržanova domneva, da je bil prašič v Puszti Közeprepassu pomemben indikator za opredelitev premoženjskega stanu pokopanega. V gomili v Sútóju je bil izven grobne kamre pokopan pes, razen tega je bilo najdenih še mnogo govejih, ovčjih in svinjskih kosti. V gomilah v Fischau so poleg goveda, svinj, ovc oz. koz našli še kosti race, v Novi Košariski pa gosi, zajca, psa, bobra, ribe ter celo jajce.²⁵² V alpskem svetu so znana posebna kulturna mesta z veliko količino živalskih kosti.²⁵³

Živalski zobje, roževinasti deli, školjke, jantar, kamni itd. so kot amuleti izpričani v mnogih kulturah. Poglobljeno razpravo je o njih napisal Ludwig Pauli, v kateri je analiziral srednjeevropske primerke in iskal razlage tako v kulturnoantropoloških študijah kot tudi v antičnih literarnih virih. Med drugim je pokazal, da se npr. jelenja roževinasta roža pojavlja pretežno v dekliških in ženskih grobovih, merjaščevi čekani pa v bojevniških.²⁵⁴

Za italiski prostor je tovrstne amulete in talismane – ki se pojavljajo na estenskem območju, v Emiliji, Umbriji, v Picenumu in Etruriji vse od časov villanovske kulture pa tja do rimske dobe – zbral Armando Cherici. Tudi tam se živalski ostanki povezujejo z grobnimi ali hekatombskimi kultu.²⁵⁵ Naj navedem le nekaj zgovornih primerov, ki kažejo na povezave z jugovzhodnoalpskim svetom. V estenskem grobišču Casa di Ricovero naj bi bil v grobu 135 žrtvovan pes;²⁵⁶ žrtvovanje psa pa je znano tudi pri Grkih, Etruščanih, Italikih in Rimljanih.²⁵⁷ Astragali goveda oz. bika (*Bos*) so bili najdeni na najdišču Ponte Nuovo v Gazzo Veronese v žarnem grobu iz 9. st. pr. n. št. skupaj

²⁵⁰ Gabrovec 1960a, 17 ss, T. 39: sl. 1; Pleterski 2008, 100 ss, sl. 3.83 in 3.84; Toškan/Štular 2008.

²⁵¹ *Most na Soči, gr. 1149, 1354, 2015*: Teržan/Lo Schiavo/Trampuž-Orel 1985, 206, 229, 322.

²⁵² Teržan 1990a, 160 s, 165, 173, 175 s, sl. 39–41, 43, 45.

²⁵³ Prispevki v Almagro-Gorbea (ur.) 1996; Zemmer-Plank/Söldner (ur.) 2002.

²⁵⁴ Pauli 1975.

²⁵⁵ Cherici 1999.

²⁵⁶ Chieco Bianchi/Calzavara Capuis 1985, 50.

²⁵⁷ Bevan 1986, 16 ss; De Grossi Mazzorin 2006, 77 ss; Salari et al. 2006, 187 ss; Lacam 2008.

canine. Contrary to Dolenjska, the cemetery at Bled revealed no red or roe deer remains. What was found was a skeleton of either a wolf or a dog, surrounded by stones, though it is not quite clear whether it formed part of the prehistoric or the Early Middle Age cemetery, which extended on the same location.²⁵⁰

The graves of the leading cemetery of the Sveta Lucija group revealed some cattle ribs and teeth as well as goat bones.²⁵¹ This by no means exhausts the list of the animal material evidence in the south-eastern Alpine area, but the material is not systematically collected and analysed so as to show which species and which parts of animals are represented at a particular site. What is certain is that the animal remains in the contexts described above represent part of the ritual tied either to the funerary cult, to the veneration of a deity of animals or to the protection against evil forces.

Animals in the funerary cult are strongly represented in western Pannonia. The Raba/Raab river basin revealed the pig as the animal most frequently found in graves and Teržan supposes that the pig at Puszta Közeprepass served as an important indicator of the economic status of the deceased. In a tumulus at Sútó, a dog was found buried outside the burial chamber, while also found were numerous cattle, sheep and pig bones. The tumuli at Fischau revealed, apart from cattle, pig and caprovid bones, also duck bones, while at Nova Košariska they also found goose, rabbit, dog, beaver and fish bones, even eggs.²⁵² Moreover, the Alpine world knows special cult places with large quantities of animal bones.²⁵³

Animal teeth, horn parts, shells, amber, stones and other objects served as amulets in numerous cultures. A more in-depth discussion on the topic was written by Ludwig Pauli, in which he analysed central European examples and sought for interpretations in both cultural and anthropological studies as well as ancient literary sources. Among other things he showed that red deer burr appeared predominantly in graves of girls or women, while wild boar tusks appeared in warrior graves.²⁵⁴

Amulets and talismans of this type in the Italic area were collected by Armando Cherici, who found them to appear in the Este area, in Emilia, Umbria, Picenum and Etruria from the period of the Villanova culture to the Roman period. Here as well, animal remains are tied to funerary or hecatomb cults.²⁵⁵ Of all the remains, I shall only cite some revealing examples that point to connections with the south-eastern Alpine area. At the Este cemetery at

²⁵⁰ Gabrovec 1960a, 78 ff, T. 39: fig. 1; Pleterski 2008, 253, Abb. 3.83 and 3.84; Toškan/Štular 2008.

²⁵¹ *Most na Soči, Gr. 1149, 1354, 2015*: Teržan/Lo Schiavo/Trampuž-Orel 1985, 206, 229, 322.

²⁵² Teržan 1990a, 160 f, 165, 173, 175 f, figs. 39–41, 43, 45.

²⁵³ See treatises in Almagro-Gorbea (ed.) 1996; Zemmer-Plank/Söldner (ed.) 2002.

²⁵⁴ Pauli 1975.

²⁵⁵ Cherici 1999.

z antenskim mečem tipa Tarquinia, ki je na Dolenjskem izpričan v okolici Velikega Vinjega vrha (Šmarjeta).²⁵⁸ Na Monte Ozol pri San Zenu pa je bilo odkrito kulturno mesto, kjer so našli trideset kozjih lobanj in ogromno količino kosti ter na kolobarje narezanih rogov (roževinastih rož); nekaj astragalnih koščic je imelo votivne napise *IERISNA*, kakršen je vrezan na negovski čeladi z Vač.²⁵⁹ Primerjave na Apeninskem polotoku lahko najdemo tudi za kavri polže (*Cyprea moneta*),²⁶⁰ na drugi strani pa v japonski skupnosti na severozahodu Balkana ter v t. i. skitskih grobiščih v Karpatskem bazenu.²⁶¹

Da so imele vse te živali poseben pomen v imaginariju železnodobnega človeka, prav tako pričajo ikonografski motivi situlske umetnosti, idoli in druge upodobitve na uporabnih predmetih (glinene figurice konjičkov, ognjiščne koze v obliki ovnovih glav, konjski in drugi protomi na čeladah, aplikacije živalskih glav na lončenini, fibule v podobi konjičev, psov ali z ovnovo oz. konjsko glavico na zaključku noge, razni obeski ter jantarne in steklene ovnove glavice v ogrlicah ipd.), ki so izraz skupnega duhovnega *koine* prazgodovinskih in antičnih družb na pragu zgodovine.²⁶²

3.3 GROBNI PRIDATKI

Od grobnih pridatkov so se ohranili v glavnem le kovinski, jantarni, stekleni in koščeni predmeti ter izdelki iz gline, le tu in tam so se skupaj z njimi ohranili leseni deli (npr. v sulicah in sekirah) ter koščki in odtisi tkanine (npr. na pasnih sponah).

Pridatki v žganih grobovih povečini niso bili poškodovani od ognja, kar pomeni, da jih niso sežigali skupaj s pokojniki, marveč so jih naknadno položili v žaro ali grobno jamo. Izjemo predstavljajo predmeti v grobovih 13/95 in 13/101 s Prelog ter koščki bronaste pločevine (verjetno situl), ki se omenjajo v nekaterih žarah.²⁶³ Sežgana je bila tudi figuralno okrašena čelada iz groba 4/1 z Laščika in druga stožčastega tipa brez ohranjenega konteksta. V nekaterih primerih je bil obročasti nakit razlomljen, preden je bil položen v žaro²⁶⁴ ali pa je bil nataknen oz. spet s fibulo.²⁶⁵

²⁵⁸ Stare V. 1973a, T. 51: 1; Tomedi 1996, 171 ss, Abb. 3; De Marinis 1999, 538, fig. 17.

²⁵⁹ Sassatelli 1999, 458 s, fig. 2–5; Istenič 1985, 326, sl. 3 z navedbo starejše literature.

²⁶⁰ Cherici 1999, 179 ss.

²⁶¹ Grahek 2004, 153 s; Kemenczei 2009, T. 1: 14, 2: 5,6, 3: 8, 10: 16 itd.

²⁶² Teržan 1990a, 136; ead. 1995c, 629 ss; ead. 1997, 667 ss; ead. 2001a, ead. 2003, ead. 2005; Bevan 1986; Šašel Kos 1999, 18 ss, 37 ss; Guggisberg/Stöllner 1996, 130 ss; Almagro-Gorbea (ur.) 1996; Zemmer-Plank/Söldner (ur.) 2002; Curci/Vitali (ur.) 2006; Metzner-Nebelsick 2007.

²⁶³ Laščik, gr. 4/1, 12/1; Preloge, gr. VII/7; Voselca, gr. 6/3.

²⁶⁴ Preloge, gr. VII/7, VII/46, 13/163.

²⁶⁵ Laščik, gr. 1892/13, 4/1; Preloge, gr. VI/15, 13/158.

Casa di Ricovero, a dog sacrifice was reportedly found in Grave 135.²⁵⁶ On that subject, dog sacrifice was practiced by the Greeks, Etruscans, Italics and Romans.²⁵⁷ At the site of Ponte Nuovo in Gazzo Veronese, cattle remains (*Bos*) were found in an urn grave from the ninth century BC together with an antenna sword of Type Tarquinia, such as was found also in Dolenjska near Veliki Vinji vrh (Šmarjeta).²⁵⁸ The cult place at Monte Ozol near San Zeno revealed thirty goat skulls and a large number of bones and sliced horns (burrs). Several astragali bore a votive inscription of *IERISNA*, the same as was found incised on a Negova helmet from Vače.²⁵⁹ Analogies for the cowrie shells (*Cyprea moneta*) can be found on the Apennine Peninsula,²⁶⁰ but also in the Iapodic community in the north-western Balkans and in the Scythian cemeteries in the Carpathian basin.²⁶¹

Further evidence of a special significance of the animals in the imagery of the Iron Age population can be found in iconographic motifs of the situla art, in idols and other representations on utilitarian objects (clay figurines of horses, firedogs in the shape of ram's heads, equine and other protoma on helmets, animal-head appliqués on pottery, fibulae in the shape of horses or dogs or with ram's or horse's heads on the terminal, amber and glass ram's heads as beads of necklaces, variously shaped pendants and other), which are a reflection of a common spiritual *koine* of prehistoric societies and classical world on the threshold of history.²⁶²

3.3 GRAVE GOODS

Of all the grave goods, mainly those made of metal, amber, glass and clay were preserved, with occasional exceptions in wood when attached to one of the above (for example to spears and axes) as well as pieces and imprints of textile (for example on belt clasps).

Goods in cremation graves were, for the most part, not damaged by fire, which signifies that they had not been cremated together with the deceased but rather subsequently laid in urns or grave pits. Exceptions to this are objects in Graves 13/95 and 13/101 at Preloge as

²⁵⁶ Chieco Bianchi/Calzavara Capuis 1985, 50.

²⁵⁷ Bevan 1986, 16 ff; De Grossi Mazzorin 2006, 77 ff; Salari *et al.* 2006, 187 ff; Lacam 2008.

²⁵⁸ Stare V. 1973a, T. 51: 1; Tomedi 1996, 171 ff, Abb. 3; De Marinis 1999, 538, fig. 17.

²⁵⁹ Sassatelli 1999, 458 f, figs. 2–5; Istenič 1985, 326, fig. 3 with references.

²⁶⁰ Cherici 1999, 179 ff.

²⁶¹ See Grahek 2004, 178 f; Kemenczei 2009, T. 1: 14, 2: 5,6, 3: 8, 10: 16 etc.

²⁶² Teržan 1990a, 136; ead. 1995c, 629 ff; ead. 1997, 667 ff; ead. 2001a, ead. 2003, ead. 2005; Bevan 1986; Šašel Kos 1999, 18 ff, 37 ff; Guggisberg/Stöllner 1996, 130 ff; Almagro-Gorbea (ed.) 1996; Zemmer-Plank/Söldner (eds.) 2002; Curci/Vitali (eds.) 2006; Metzner-Nebelsick 2007.

V skeletnih grobovih je iz opisane ali skicirane lege predmetov na okostju (sl. 34, 35, 37) moč razbrati, da so bili preminuli pokopani v pogrebni opravi z bolj ali manj bogatimi dodatki, posodje pa je bilo običajno položeno k nogam. Položaj predmetov v grobu bo podrobneje predstavljen v sklopu analize posameznih prvin noše.

Struktura pridatkov

Med grobnimi sestavi so vidne razlike že na prvi pogled; odražajo se v različnih zvrsteh in kombinacijah predmetov, na čemer pravzaprav temeljijo študije noš in družbene diferenciacije. S tem vprašanjem se je že leta 1980 ukvarjala Teržanova.²⁶⁶ Za vzorec je uporabila sestave pridatkov iz 359 grobov, ki so prišli na dan ob izkopavanjih vojvodinje Mecklenburške in so celovito predstavljeni v Hencknovi kataloški objavi (1978). Od teh jih je 29,9 % označila za neuporabne in 19 % kot neopredeljene, med preostalimi je določila 26,5 % grobov z napadalnim orožjem in 25,6 % brez orožja. V skupini grobov brez orožja jih je 7,5 % pripisala moškim, 9,5 % ženskam in 8,6 % otrokom. Ta razmerja kažejo določeno anomalijo v korist odrasle moške populacije, ki je zastopana s 34 %, medtem ko so odrasle ženske prepoznane le v slabih desetih odstotkih, zato bi predpostavljali, da se med neopredeljenimi grobovi skrivajo pretežno ženski pokopi. V sestavih z napadalnim orožjem je razčlenila strukturo oborožitve: 4,8 % grobov je vsebovalo le eno sulico, 7 % eno sekuro, 5,6 % je imelo eno sulico in eno sekuro, 2,7 % grobov dve sulici, 6,4 % grobov pa dve sulici in eno sekuro. Ugotovila je, da so razmerja v strukturi grobnih pridatkov na Magdalenski gori in v Dolenjskih Toplicah precej podobna in se bistveno razlikujejo od deležev, zastopanih na Vačah, v Stični, Brezju in Podzemlju, kjer je bilo kar za polovico manj grobov z orožjem. To stanje je delno pripisala kronološkim razlikam med najdišči, deloma pa gospodarski usmerjenosti posameznih skupnosti, pri čemer je Magdalensko goro označila za trgovsko središče.²⁶⁷

Grobne sestave, ki jih hrani dunajski muzej, je obravnavala Bergonzijeva v študiji, objavljeni leta 1981. Tudi ona jih je razdelila glede na zastopanost orožja v dve skupini, pri čemer je upoštevala le najbolj reprezentativne grobove. Od skupno 266 grobnih celot, kolikor jih je z Magdalenske gore inventariziranih v muzejski zbirki, je v analizo vključila 48 grobov. V skupini brez orožja je zajela dvanajst grobov iz gomile 2 in deset grobov iz gomile 13 na Prelogah ter šest grobov iz gomile 2 na Voselci pri Hrastju, skupno torej 28 grobov. Od grobov z orožjem jih je upoštevala šest iz gomile 2 in trinajst iz gomile 13 na Prelogah ter enega iz gomile 2 z Voselce pri Hrastju. V to skupino je pritegnila še en grob iz gomile VII na Prelogah in tri iz gomile V na Laščiku, ki jih je

²⁶⁶ Teržan 1985.

²⁶⁷ *Ibid.*, sl. 15–17.

well as pieces of bronze sheet metal (probably of situlae), mentioned in some of the urns.²⁶³ Also burnt were a helmet with figural decoration from Grave 4/1 at Laščik and another conical helmet without a preserved context. Ring jewellery was in some graves broken up before being laid into the urn²⁶⁴ or was tied with a fibula.²⁶⁵

In inhumation graves, the described or drawn position of objects on the skeletons (figs. 34, 35, 37) testifies to the deceased being buried in their more or less richly adorned funerary dress, usually with ceramic vessels laid at their feet. The position of grave goods will be presented below, within the analysis of individual elements of the costume.

Structure of grave goods

Grave groups show a great variety of types and combinations of objects placed in graves, which represents the basis for the studies of costume and social stratification. Such a study on the material from Magdalenska gora was published already in 1980 by Teržan.²⁶⁶ She used 359 grave groups as her sample, which were excavated by the Duchess of Mecklenburg and were integrally presented in Hencken's catalogue (1978). Of the 359 grave groups, 29.9% were deemed unusable and 19% undetermined. The remainder included 26.5% of graves with offensive weapons and 25.6% without weapons. Of the latter, 7.5% of graves were identified as male, 9.5% as female and 8.6% of children. These percentages show a certain anomaly in favour of adult male population, represented with 34%, while adult female were identified in less than ten per cent; this could lead to the assumption that the undetermined graves are mainly female. For the grave groups with offensive weapons she also analysed the structure of armament and found 4.8% of graves only had a spear, 7% an axe, 5.6% a spear and an axe, 2.7% two spears and 6.4% two spears and an axe. She observed that the ratios in the structure of grave goods at Magdalenska gora and Dolenjske Toplice bore a close resemblance and, at the same time, differed substantially from those at Vače, Stična, Brezje and Podzemelj, where graves with weapons were half as represented as at Magdalenska gora. She ascribed this disproportions partly to chronological differences among sites and partly to the economic orientation of individual communities, whereby she marked Magdalenska gora as a commercial centre.²⁶⁷

Grave groups kept at the museum in Vienna were analysed by Bergonzi in a study published in 1981. She also divided the groups according to the presence or

²⁶³ *Laščik, Gr. 4/1, 12/1; Preloge, Gr. VII/7; Voselca, Gr. 6/3.*

²⁶⁴ *Preloge, Gr. VII/7, VII/46, 13/163.*

²⁶⁵ *Laščik, Gr. 1892/13, 4/1; Preloge, Gr. VI/15, 13/158.*

²⁶⁶ Teržan 1985.

²⁶⁷ *Ibid.*, Abb. 15–17.

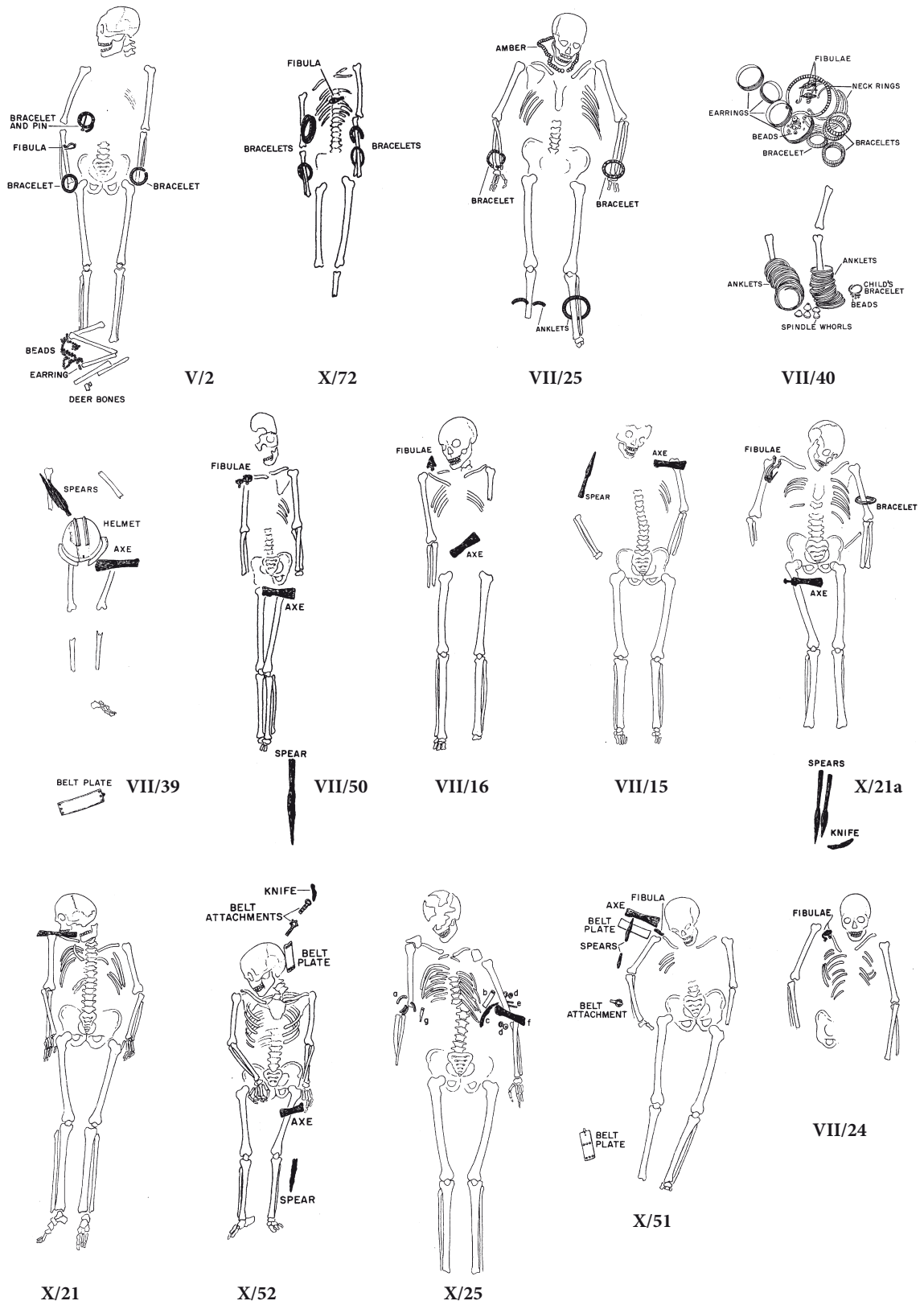

Sl. 37: Položaj predmetov v skeletnih grobovih na Magdalenski gori, odkritih v okviru izkopavanj vojvodine Mecklenburške (po Hencknu 1978, Fig. 102, 242, 244, 258, 260, 271, 287, 289, 309, 311, 316, 340, 342, 356).

Fig. 37: Position of objects in inhumation graves at Magdalenska gora unearthed during the excavations by the Duchess of Mecklenburg (after Hencken 1978, Figs. 102, 242, 244, 258, 260, 271, 287, 289, 309, 311, 316, 340, 342, 356).

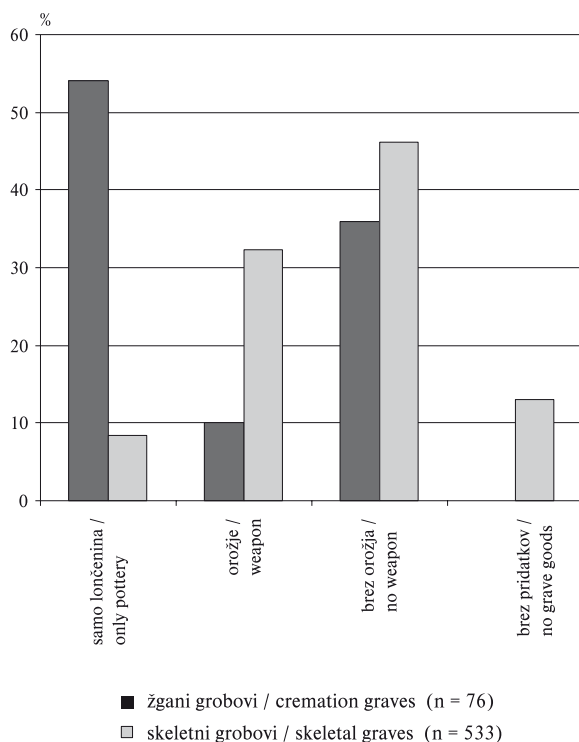

Sl. 38: Struktura pridatkov v žganih, skeletnih in neopredeljenih pokopih na Magdalenski gori.

Fig. 38: Structure of grave goods in cremation, inhumation and undefined burials at Magdalenska gora.

izkopala vojvodinja Mecklenburška, skupaj torej 24.²⁶⁸ Z objavo vsega gradiva iz magdalenskogorskih gomil in ovrednotenjem primarnih virov pa je zdaj možen bolj celovit vpogled v grobne sestave in preverjanje ugotovitev, ki so bile podane na osnovi manjših vzorcev.

Najprej si oglejmo strukturo pridatkov v žganih grobovih (sl. 38), ki sodijo v čas starejšega halštatskega obdobja, kakor smo lahko ugotovili v poglavju o načinu pokopa. Od približno stotih žganih pokopov (sl. 12: B, 20, 25 in 27) je za analizo uporabnih 76 grobov, od katerih jih je 22,4 % vsebovalo samo žaro, 31,6 % grobov pa je imelo poleg žare še kakšno glinasto posodo. V približno 36 % grobov so našli tudi fibule, obročasti nakit, gumbice ali okove in brusni kamen. Orožje je zastopano le v borih 10 % žganih pokopov, od tega je 7 grobov vsebovalo nože (če jih štejemo za orožje), v 3 grobovih so bile sulične osti, v enem (morda dveh) primerih nastopa čelada in v enem grobu sekira. Takšen delež grobov z orožjem je zelo blizu odstotkom, ki jih navaja Teržanova za starejše halštatske pokope na Vačah, v Stični, na Brezju in v Podzemlju, kjer se se njihov delež giblje od 8,3 do 14,8 %.²⁶⁹

Na Magdalenski gori je bilo odkritih zanesljivo 448 skeletnih grobov, za 152 grobov pa nimamo podatkov o načinu pokopa (sl. 12: B). Od teh sem v analizo vključila 533 grobov (sl. 38), pri ovrednotenju podatkov sem se

absence of weapons, taking into consideration only the most representative graves. Of the total 266 grave groups from Magdalenska gora, she included only 48 in her analysis. The group without weapons included twelve graves from Tumulus 2 and ten from Tumulus 13 at Preloge, as well as six from Tumulus 2 at Voseleca, thus altogether 28 graves. The group with weapons, on the other hand, included six from Tumulus 2 and thirteen from Tumulus 13 at Preloge, as well as one from Tumulus 2 at Voseleca. The latter group further included one grave from Tumulus VII at Preloge and three from Tumulus V at Laščik, all excavated by the Duchess, thus altogether 24.²⁶⁸ Today, the material from the tumuli of Magdalenska gora is integrally published and the primary sources evaluated; this enables us to gain a greater insight into the grave groups and to verify the findings based on smaller samples.

Having the integral data at hand, the first structure to be looked at is of grave goods in cremation graves (fig. 38) from the Early Hallstatt period. Of the roughly hundred cremation burials (figs. 12: B, 20, 25 and 27), 76 can be used for analysis, of which 22.4% contained only an urn and 31.6% an urn and another ceramic vessel. In approximately 36% of graves fibulae, ring jewellery, buttons or fittings and a whetstone were also found. Weapons were found in only 10% of cremation graves, of which 7 contained knives (if considered as weapons), 3 contained spearheads, one (possibly two) contained a helmet and one grave an axe. This share of graves with weapons comes close to those observed by Teržan for the Early Hallstatt burials at Vače, Stična, Brezje and Podzemelj, their share there being between 8.3 and 14.8%.²⁶⁹

As for inhumation graves, the cemeteries at Magdalenska gora revealed 448 graves that are incontrovertibly inhumations, while there are further 152 graves for which no data as to the burial rite exists (fig. 12: B). The analysis was made on 533 graves (fig. 38), while the evaluation of data was based mainly on primary sources rather than on the museum collections only, since the grave groups could have gotten mixed in subsequent handling, as is the case with the Mecklenburg Collection. Moreover, at the museum in Vienna, individual objects went missing from certain grave groups, while the fund of typologically inventoried finds at the National Museum of Slovenia only allowed partial reconstructions of some of the grave groups.

The inhumations and undetermined graves (burial rite not noted, but inhumation supposed from grave pit size) contained three times more weapons than the cremation graves, while the percentage of graves with pottery as the only grave good is significantly lower (fig. 38). This result is different from that presented by Teržan, the reason for that mainly being that her sample

²⁶⁸ Bergonzi 1981, tab. B in D.

²⁶⁹ Teržan 1985, sl. 15–17.

²⁶⁸ Bergonzi 1981, tab. B and D.

²⁶⁹ Teržan 1985, Abb. 15–17.

Gomila Tumulus	Pokop / Burial rite		Št. grobov / No. of graves				
	skeletni skeletal	neznan no data	pridatki neznani no data of gr. goods	brez pridatkov no gr. goods	samo z lončenino only pottery	z orožjem with weapon	brez orožja no weapon
P II	4	22	11	1	-	4	10
P IV	25	37	17	6	1	19	19
L V	47	5	-	10	1	25	16
P VI	12	3	1	1	-	6	7
P VII	35	3	1	4	-	15	18
P VIII	15	3	2	2	-	7	7
P X	76	-	1	19	2	24	30
P 2	59	44	1	-	12	32	58
P 13	156	3	-	26	28	36	69
V 2	9	9	-	-	1	4	13
Skupaj Total	438	129	34 (6 %)	69 (12 %)	45 (8 %)	172 (30 %)	247 (44 %)

Sl. 39: Struktura skeletnih in neopredeljenih pokopov po gomilah na Magdalenski gori.
Fig. 39: Structure of inhumation and undefined burials in individual tumuli at Magdalenska gora.

oprla predvsem na primarne vire in ne zgolj na stanje v muzejskih zbirkah, kajti grobne celote so bile lahko pozneje zamešane, kar v dobri meri velja za Mecklenburško zbirko. V dunajskem muzeju so iz nekaterih grobnih celot umanjali posamični predmeti, iz fonda tipološko inventariziranih najdb v Narodnem muzeju Slovenije pa se je dalo samo deloma sestaviti nekaj grobnih celot.

Iz prikazanih razmerij je razvidno, da je v skeletnih in neopredeljenih grobovih (način pokopa ni zabeležen, po velikosti grobnih jam pa domnevamo, da je bil skeleten) kar trikrat več orožja kot v žganih grobovih, hkrati je bistveno manjše število grobov, kjer je bila lončenina edini pridatek. Na tem mestu je zagotovo potreben komentar k razlikam v deležih, kot jih je izračunala Teržanova, in temi, ki so prikazani na sl. 38. Razlog je predvsem ta, da so v njenem vzorcu zajete le grobne celote iz Mecklenburške zbirke, ne oziraje se na način pokopa.

Vse te osnovne kategorije grobov – z orožjem ali brez njega, samo s keramiko ali pa brez slehernih trajnejših pridatkov – so zastopane malodane v vseh gomilah, vendar ne z enakim deležem (sl. 39). Največ bojnih oprav je bilo v gomili V na Laščiku; prav nasprotno kažejo razmerja grobov v gomilah 2 in 13 na Prelogah ter iz gomile 2 na Voselci pri Hrastju, kjer je bilo odkritih skoraj dvakrat več oprav brez orožja kot pa z orožjem, medtem ko je bilo največ grobov brez pridatkov zabeleženih v gomili X na Prelogah. Brez nadaljnje analize strukture grobov in upoštevanja časovne dimenzije si je težko razložiti, kaj se pravzaprav skriva za temi razlikami.

3.3.1 GROBOVI BREZ PRIDATKOV

Za razumevanje strukture družbe in dogajanj so grobovi brez pridatkov enako pomembni kot najbogatejši grobovi, saj predstavljajo drugo plat razslojene družbe. Na pokojnike, ki niso imeli ničesar, kar bi se trajneje ohranilo, so naleteli skorajda v vseh gomilah (sl. 39),

only included grave groups from the Mecklenburg Collection irrespective of the burial rite.

All these basic categories of grave groups – with or without weapons, with pottery as the only grave good or without goods – were documented in almost all tumuli, but not with equal percentages (fig. 39). Tumuli IV, VI, VII, VIII and X at Preloge show a roughly equal share of graves with and without weapons, while Tumulus V at Laščik revealed significantly more graves with weapons. Quite the opposite was observed in Tumuli 2 and 13 at Voselca, where the number of weaponless graves is twice that of graves with weapons, while Tumulus X reveals a substantial number of graves without any grave goods. These differences are quite marked, but can only be explained by further analysing the structure of graves and by keeping in mind their chronological dimension.

3.3.1 GRAVES WITHOUT GRAVE GOODS

The road to understanding the social structure and differentiation is paved both with burials without grave goods as well as the richest graves, which represent opposite faces of a stratified society. Deceased with no goods in their graves were found in almost all of the tumuli (fig. 39), with the exception of those dug up completely or partially in the first campaigns, when graves had not been carefully documented and many times neither the burial rite nor the grave goods were noted. From later excavations, only in Tumulus 2 at Voselca and Tumulus 2 at Preloge were graves without grave goods not documented, whereby in a rough estimate only a third of the grave groups has been preserved at the latter, since Pečnik dug the tumulus for the museum in Ljubljana at first without documenting the graves. Comparatively the greatest share of inhumation graves without goods was documented in Tumulus X at Preloge, which apparently surprised

z izjemo tistih, ki so bile prekopane ali načete v prvih akcijah, ko grobov niso pazljivo dokumentirali in velikokrat niso zabeležili niti načina pokopa niti pridatkov v njih. Iz poznejših izkopavanj taki pokopi niso znani le iz gomile 2 na Voselci in gomile 2 na Prelogah, vendar je iz slednje po grobi oceni ohranjenih zgolj tretjina grobnih celot, saj jo je Pečnik spočetka kopal za ljubljanski muzej in grobov ni dokumentiral. Sorazmerno največji delež skeletnih grobov brez pridatkov so zabeležili v gomili X na Prelogah, kar je očitno presenetilo tudi vojvodinjo Mecklenburško, ki jo je označila za "gomilo sužnjev".²⁷⁰

Pri poskusu razlage tega fenomena se najprej dotaknimo vprašanja spolne in starostne strukture, na katero je moč dobiti odgovor le z analizo kostnih ostankov. Na srečo si pri tem lahko pomagamo z izsledki Angela, čeprav jih zaradi premajhnega vzorca ne moremo šteti za reprezentativne, a vendarle. Med njimi najdemo moške zrelih let,²⁷¹ pa tudi mlajšega odraslega moškega²⁷² in mlade odrasle ženske.²⁷³ Razen tega so med njimi zastopani domala vsi morfološki tipi po Angelu (sl. 5–7).²⁷⁴ V terenskem dnevniku Brattine, ki je sodeloval pri kopanju gomile 13 na Prelogah, zasledimo podatek, da je bilo v grobu 13/149 najdeno otroško okostje, v grobu 13/21 pa 170 cm dolg skelet, kar govori za odraslo osebo (sl. 8). Vse to dokazuje, da se pokopi brez pridatkov ne navezujejo na določen spol ali starostno skupino.

Če si ogledamo še njihovo zastopanost po gomilah, lahko vidimo, da se pojavljajo tako v gomilah z najprestižnejšimi pokopi (Laščik, gom. V; Preloge, gom. IV, VII in 13) kot tudi v revnejših gomilah (Preloge, gom. X). Proporcionalno največji delež pokopov brez pridatkov pa sta vsebovali gomili V na Laščiku (19,2 %) in X na Prelogah (25,4 %), ki sta dosegli višek v negovski stopnji.²⁷⁵ Ali gre torej za fenomen, ki je bolj kot s socialno diferenciacijo povezan s spremembami v poznem halštatskem obdobju?

Toda kako datirati pokope brez pridatkov? Nekaj možnosti ponuja analiza stratigrafskih odnosov, zato si pogledjmo situacijo v gomili X na Prelogah, ki jo prikazuje delni tloris (sl. 40). V desni polovici načrta bi lahko prepoznali krožni potek pokopov na SZ predelu gomile. Po grobnih pridatkih je v tem delu najstarejši grob 22 iz časa kačastih fibul, sledita pokopa 23 in 24 iz zgodnje stopnje certoških fibul, grob 13 je domnevno iz zgodnjega negovskega časa, medtem ko sta grobova 18 in 21a iz pozne negovske stopnje. Okostje s številko 19, ki je ležalo nad grobom 18, ni imelo pridatkov, prav tako ne oseba s številko 15a, ki je bila pokopana v bližini grobov 13 in 14 iz certoške ali negovske stopnje. Brez pridatkov je bil

even the Duchess of Mecklenburg, who named it "the tumulus of slaves".²⁷⁰

An attempt at explaining this phenomenon should first consider the question of the sex and age structure, which can only be answered by analysing the bone remains. Here we can use Angel's findings, albeit hindered by a small sample that lacks representativeness. Angel identified adult males,²⁷¹ a young adult male²⁷² and a young adult female,²⁷³ whereby all morphological types were represented (figs. 5–7).²⁷⁴ Another piece of information on the subject can be found in the field diary of Brattina, who assisted in digging Tumulus 13 at Preloge and stated that a child's skeleton was found in Grave 13/149 and a 170cm long skeleton in Grave 13/21, the latter speaking for an adult individual (fig. 8). The above shows that burials without grave goods are not limited to a particular sex or age group.

Graves without goods appear both in tumuli with the richest burials (Laščik, Tum. V; Preloge, Tum. IV, VII and 13) and in poorer tumuli (Preloge, Tum. X). Proportionally the greatest share was documented in Tumulus V at Laščik (19.2%) and in Tumulus X at Preloge (25.4 %), which witnessed their peaks in the Negova phase.²⁷⁵ Is it then a phenomenon tied more to the changes in the Late Hallstatt rather than to social differentiation?

The question in that respect is how to date burials without grave goods. Answers might be provided by stratigraphic relationships, which will be analysed on the example of Tumulus X at Preloge as shown by a partial ground-plan (fig. 40). The right half of the ground-plan indicates a circular pattern of burials in the NW part of the tumulus. According to grave goods, the earliest in this part of the tumulus is Grave 22, from the Serpentine Fibulae phase, followed by Graves 23 and 24 from the Early Certosa phase, Grave 13 supposedly from the Early Negova phase and Graves 18 and 21a from the Late Negova phase. Skeleton no. 19, without grave goods, was found lying above Grave 18, individual no. 15a was also without grave goods and was buried near Graves 13 and 14 from either the Certosa or Negova phases. Without grave goods was also Skeleton no. 3, lying under Skeleton no. 4 with a Certosa phase costume. Goods were also not found with the skeletons marked with nos. 1, 5–9, 11, 17; these deceased were not buried in a circular pattern, which indicates a deviation from the general rule observed in the tumuli of Dolenjska. This situation points to burials without grave goods dating to the last phase of the Early Iron Age. On that subject, Goldberg's descriptions reveal that bare skeletons were

²⁷⁰ Hencken 1978, 66.

²⁷¹ Preloge, gr. IV/10, IV/18, X/6, X/53.

²⁷² Preloge, gr. X/7.

²⁷³ Laščik, gr. V/24, V/44–45.

²⁷⁴ Angel 1968. Glej tu poglavje 1.1.3.

²⁷⁵ Tecco Hvala/Dular/Kocuvan 2004, sl. 50, 52.

²⁷⁰ Hencken 1978, 66.

²⁷¹ Preloge, gr. IV/10, IV/18, X/6, X/53.

²⁷² Preloge, Gr. X/7.

²⁷³ Laščik, Gr. V/24, V/44–45.

²⁷⁴ Angel 1968. See here Chapter 1.1.3.

²⁷⁵ Tecco Hvala/Dular/Kocuvan 2004, Abb. 50, 52.

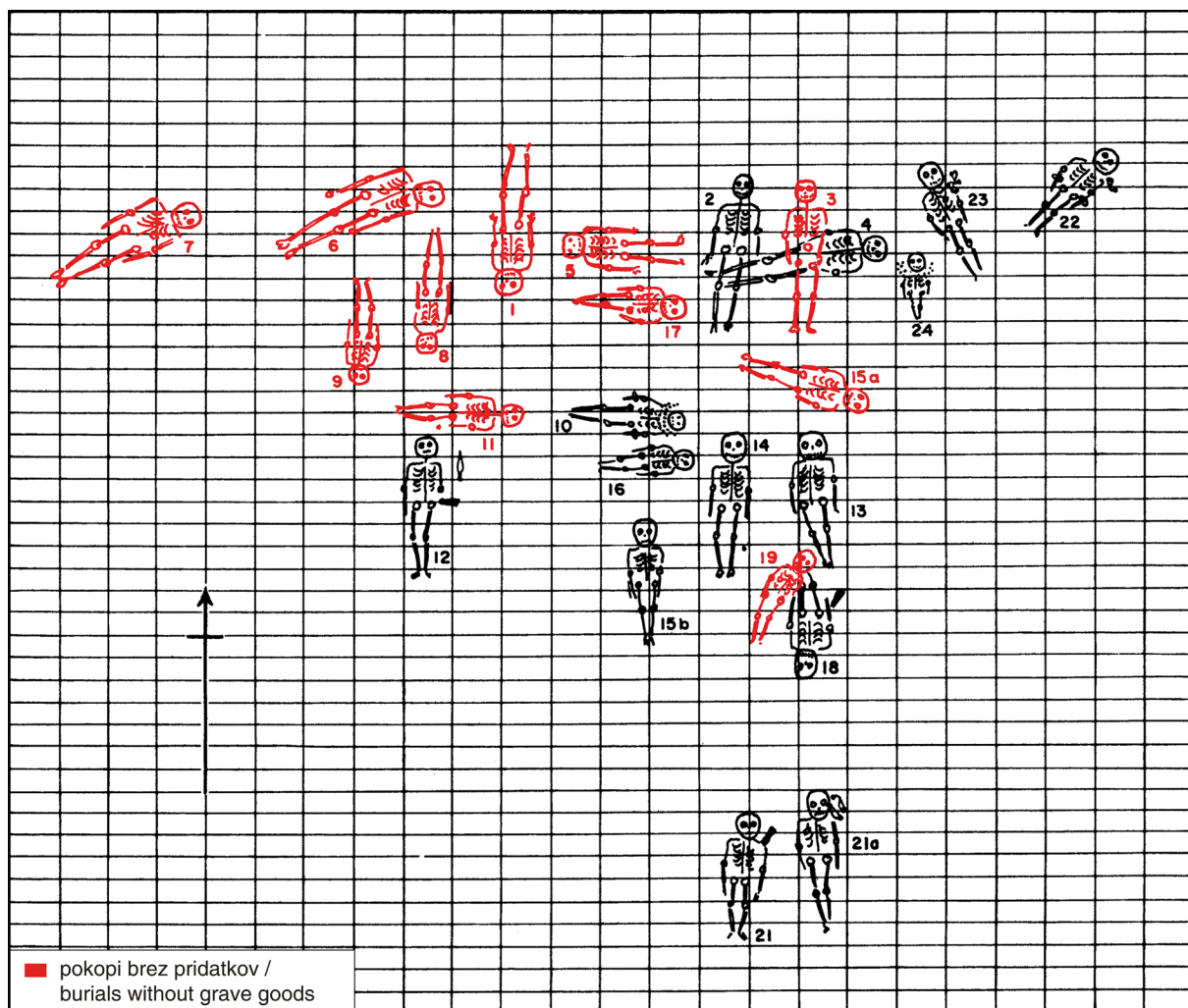

Sl. 40: Delni tloris gomile X na Prelogah z označenimi pokopi brez pridatkov (po Hencknu 1978, Fig. 298).

Fig. 40: Partial ground-plan of Tumulus X at Preloge with marked burials without grave goods (after Hencken 1978, Fig. 298).

tudi skelet s številko 3, ki je ležal pod okostjem 4 z opravo iz certoškega časa. Nobenih pridatkov niso našli niti pri severozahodno ležečih skeletih, označenih s številkami 1, 5–9, 11, 17. Ti pokojniki niso bili pokopani v krožnem redu, kar nakazuje odstopanje od splošnega pravila, ki naj bi veljalo za dolenske gomile. Iz opisane situacije bi tako lahko razbrali, da sodijo pokopi brez pridatkov v najmlajši stopnji starejše železne dobe. Iz Goldbergovih opisov vzemo, da so na gola okostja naleteli tudi na skrajnem južnem in vzhodnem robu gomile.²⁷⁶

S stratigrafsko analizo smo poskušali take grobove časovno opredeliti tudi v okviru gomile 13 na Prelogah. Po merskih podatkih, ki jih je zabeležil Brattina, se je namreč dalo rekonstruirati njen tloris (sl. 41). Gomila je bila podolgovate oblike, v osi SZ–JV je merila 63 m, v osi SV–JZ pa 31 m, v najvišji točki je dosegla 5,30 m višine, kar je razvidno iz Szombathyjeve skice, ki je v prerezu

also found in the southernmost and easternmost edges of the tumulus.²⁷⁶

The analysis of stratigraphic relationships was also applied to Tumulus 13 from Preloge, since the measurements provided by Brattina allowed for a reconstruction of its ground-plan (fig. 41). The tumulus was oblong, measuring 63m in the NW–SE axis and 31m in the NE–SW axis, it reached a maximum height of 5.30m, as is discernible from Szombathy's sketch documenting several layers of earth.²⁷⁷ Most burials without grave goods were lying at fairly shallow depths in the tumulus and above the graves from the Serpentine and Certosa Fibulae phases.²⁷⁸ Excavators' notes bring additional data on the positions of such graves in other tumuli at Preloge – Grave IV/29 supposedly lay above Grave 32

²⁷⁶ Gr. X/47, X/74, X/72: Hencken 1978, 74, 79, fig. 298.

²⁷⁷ Tecco Hvala/Dular/Kocuvan 2004, 142 ff, Abb. 27 and 28.

²⁷⁸ *Ibid.*, 183, compare figs. 48 and 49.

²⁷⁶ Gr. X/47, X/74, X/72: Hencken 1978, 74, 79.

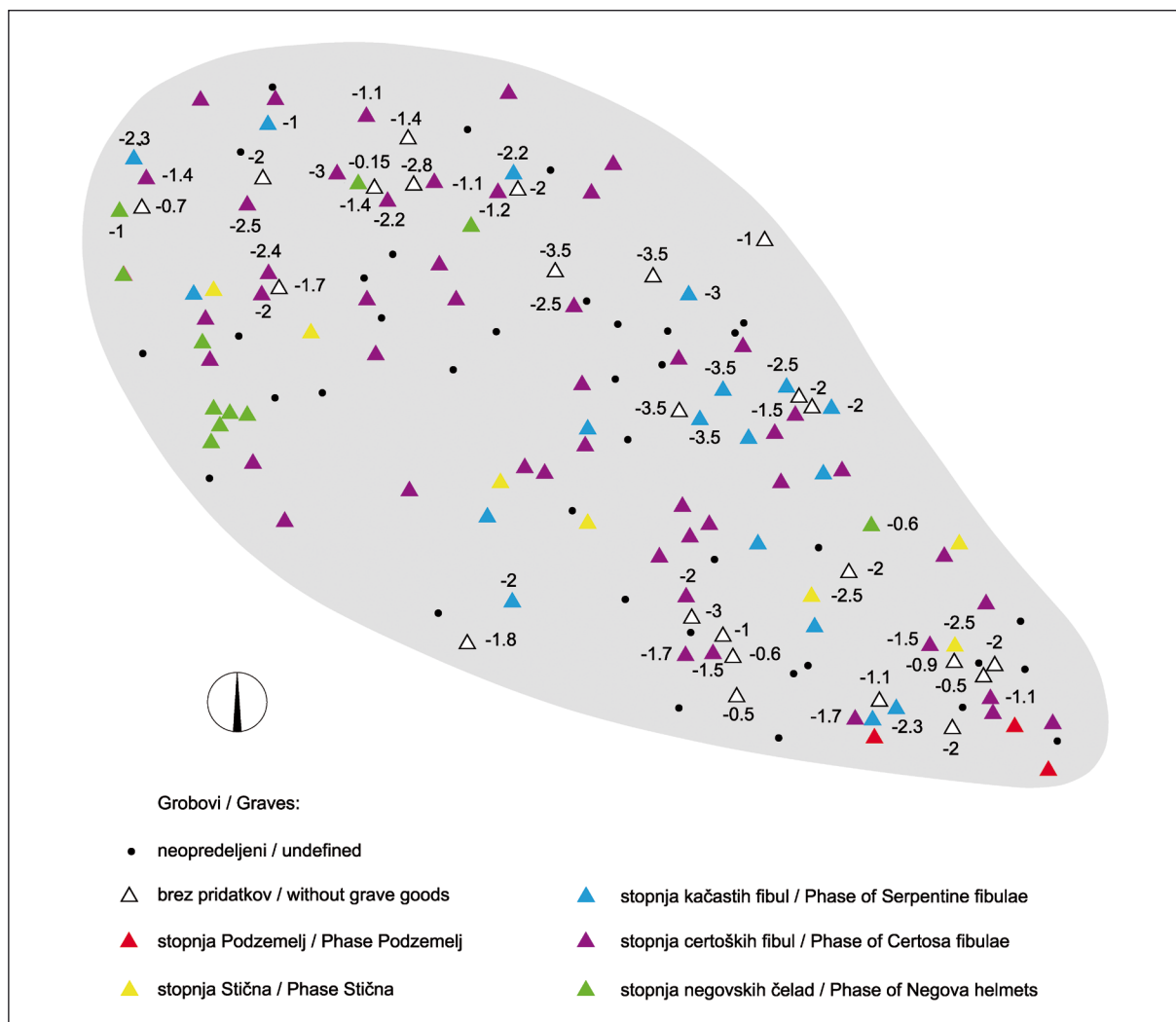

Sl. 41: Rekonstruiran tloris gomile 13 na Prelogah s skeletnimi pokopi brez pridatkov (po Tecco Hvala/Dular/Kocuvan 2004, sl. 49).

Fig. 41: Reconstructed ground-plan of Tumulus 13 at Prelogah with inhumation graves without goods (after Tecco Hvala/Dular/Kocuvan 2004, Abb. 49).

dokumentiral več nasutij.²⁷⁷ Izkazalo se je, da je večina pokopov brez pridatkov ležala dokaj plitvo v gomili in nad grobovi iz časa kačastih in certoških fibul.²⁷⁸ V zapisih izkopavalcev najdemo še nekaj podatkov o legi tovrstnih grobov v drugih gomilah na Prelogah – grob IV/29 naj bi ležal nad grobom 32 iz negovske stopnje, grob VII/43 pa zraven groba 42 iz pozne certoške faze. V gomili V na Laščiku so menda zadeli na dva taka pokopa tik pod rušo na JV robu gomile (Goldberg jih ni oštevilčil), dva pa na severni strani (V/22 in V/24).²⁷⁹

Na osnovi modernejših raziskav v Stični je Gabrovec podal rekonstrukcijo nastajanja gomile: najprej so nad centralnim grobom nasuli prvo gomilo, okoli nje je postopno nastal prvi krog grobov, ki ga je prekrilo novo nasutje, nato drugi krog in čezenj nov plašč

from the Negova phase and Grave VII/43 lay beside Grave 42 from the Late Certosa phase. In Tumulus V at Laščik, they came across two such burials just under the turf in the SE part of the tumulus (Goldberg did not assign them a number) and further two on the northern side (V/22 and V/24).²⁷⁹

The cemetery at Stična was investigated in more recent time and on this basis Gabrovec was able to put forward a reconstruction of how a tumulus was created: the central grave was covered by the first earthen mound, around which the first ring of graves was gradually made, covered by another earthen mound, then followed the second ring of graves and another mound and so forth.²⁸⁰ Such a reconstruction presupposes that the graves at the edge of a tumulus

²⁷⁷ Tecco Hvala/Dular/Kocuvan 2004, 52 ss, sl. 27 in 28.

²⁷⁸ Ibid., 105, primerjaj sl. 48 in 49.

²⁷⁹ Hencken 1978, 22 s, 34, 41 (gr. V/A in B), 59 s.

²⁷⁹ Hencken 1978, 22 f, 34, 41 (Gr. V/A and B), 59 f.

²⁸⁰ Gabrovec 1974a, 172 ff; *id.* 1999, 151 ff; *id.* 2008, 37 ff, Abb. 19, 21, 23; Teržan 2008, 233 ff.

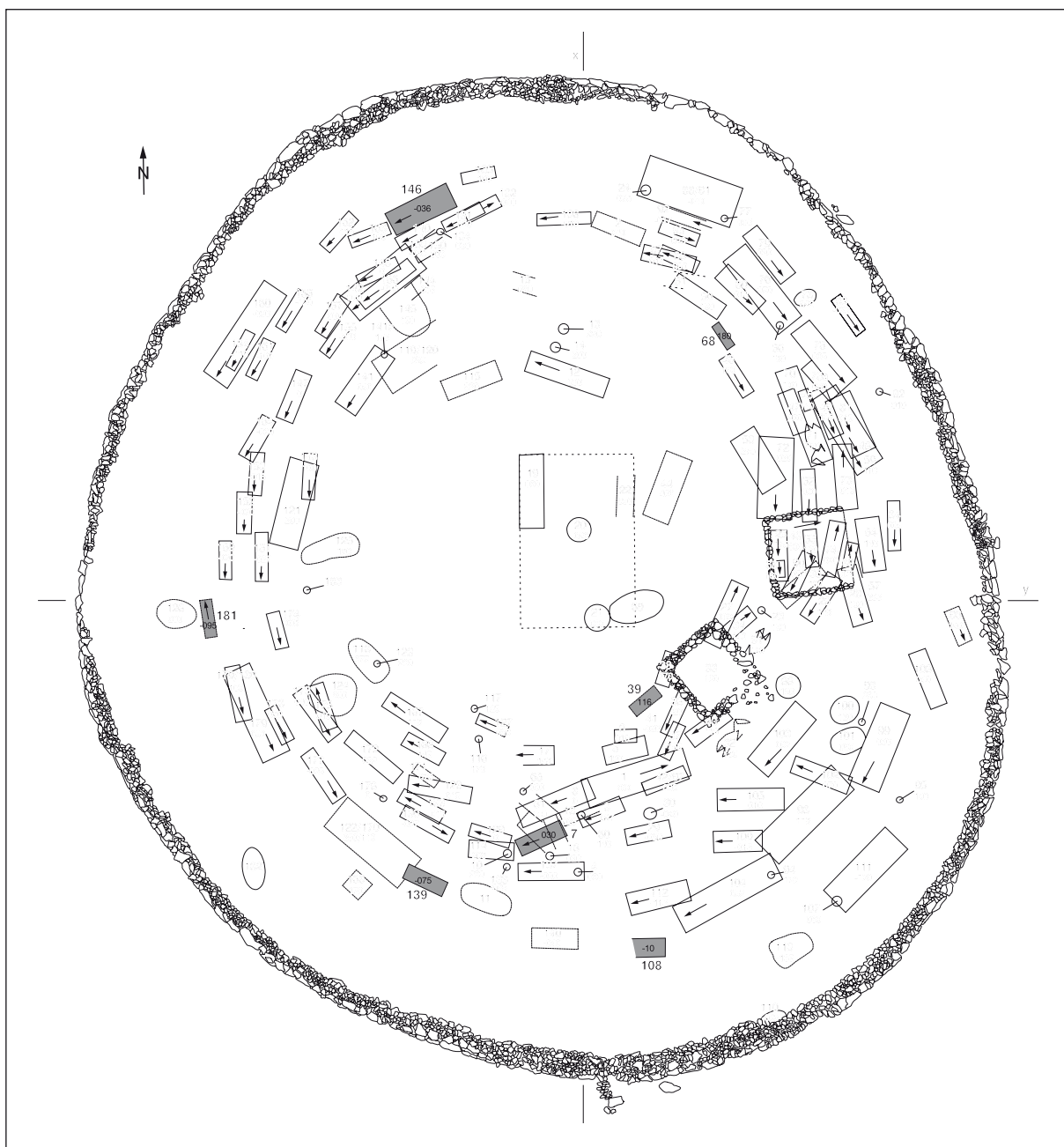

Sl. 42: Grobovi brez pridatkov v gomili 48 v Stični (po Gabrovcu et al. 2006, pril. 1).
 Fig. 42: Graves without goods in Tumulus 48 at Stična (after Gabrovec *et al.* 2006, Beil. 1).

itd.²⁸⁰ Iz te predpostavke izhaja nasledek, da so grobovi na obrobju gomile in v vrhnjih plasteh predstavljali najmlajše pokope. Če si ogledamo situacijo v stiški in novomeških gomilah (sl. 42 in 43), lahko ugotovimo, da so pokopi brez pridatkov tudi tam pogosto ležali na zunanji krožnici ali v vrhnjem plašču gomile. Gotovo so bili med njimi nekateri izropani ali poškodovani z naknadnimi vkopi oz. s kasnejšimi zemeljskimi deli, zagotovo pa ne vsi. V gomili 48 iz Stične (sl. 42) bi

²⁸⁰ Gabrovec 1974a, 172 ss; id. 1999, 178 ss; id. 2008, 37 ss, sl. 19, 21, 23; Teržan 2008, 233 ss.

and in top-most earthen layers were the latest in date. At Stična and Novo mesto (figs. 42 and 43), graves without goods were often found on the outer line of the tumulus or in the top layer of the tumulus. These graves surely included those that were either robbed or damaged, but not all were like that. In Tumulus 48 at Stična (fig. 42), burials without goods would be in Graves 139, 181 and 146 in the outer circle and Graves 39 and 68, found rather high in the tumulus (116 to 180cm), at the same height as neighbouring Graves 36 or 48 and 50, which Gabrovec set into the fourth phase

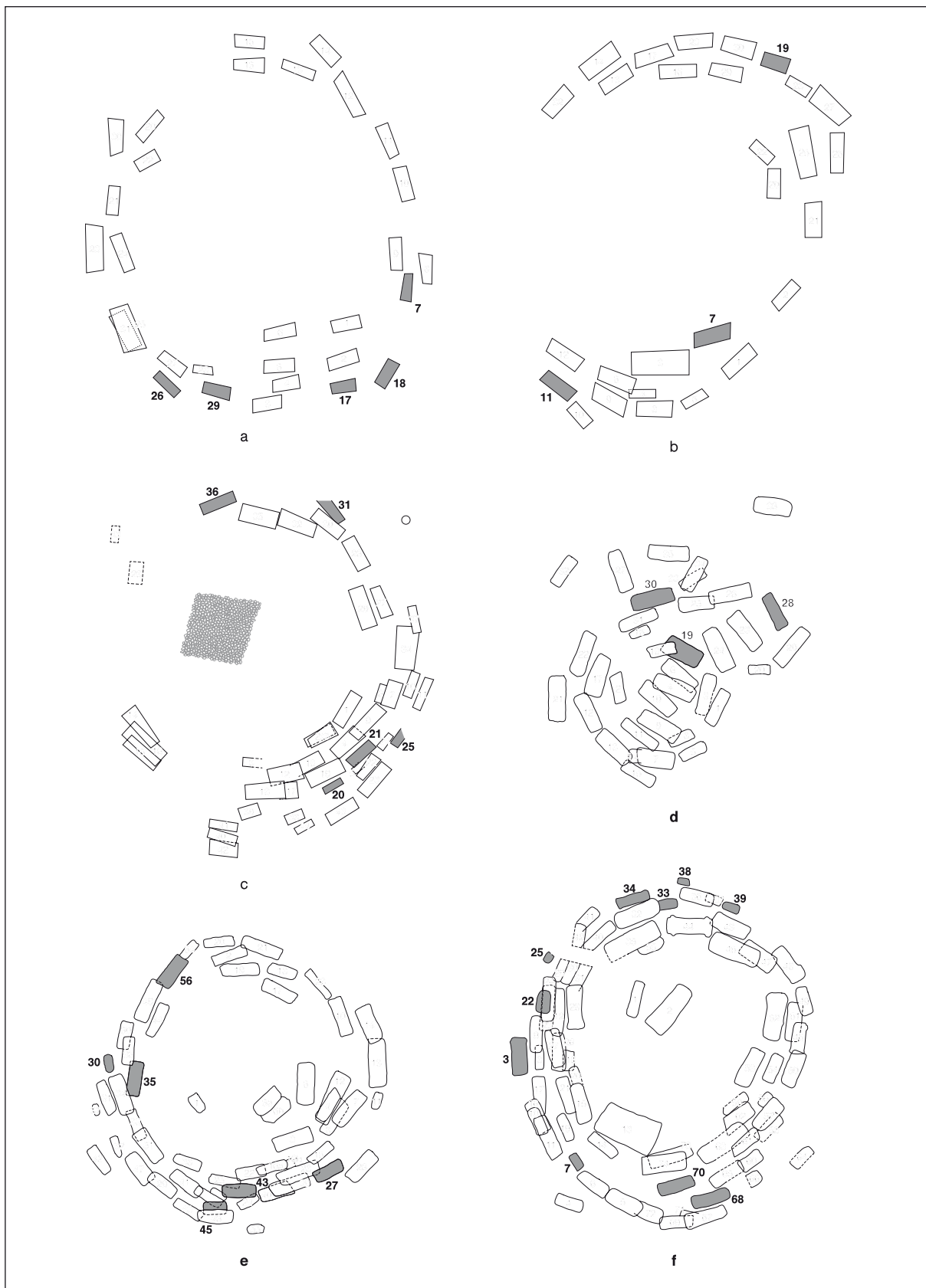

Sl. 43: Grobovi brez pridatkov v gomilah v Novem mestu (po Knezu 1986; id. 1993 in po Križu 1997; id. 2000).

Fig. 43: Graves without goods in tumuli at Novo mesto (after Knez 1986; id. 1993; Križ 1997; id. 2000).

a – Znančeve njive, Tum. 1; b – Znančeve njive, Tum. 4; c – Kapiteljska njiva, Tum. 1; d – Kapiteljska njiva, Tum. 2;
e – Kapiteljska njiva, Tum. 3; f – Kapiteljska njiva, Tum. 5.

med pokope brez pridatkov lahko šteli grobove 139, 181 in 146 v zunanjem krogu ter grobova 39 in 68, ki sta ležala precej visoko v gomili (116 do 180 cm) oz. na enakih višinah kot sosednji grobovi 36 ali 48 in 50, ki jih je Gabrovec uvrstil v 4. fazo pokopavanja.²⁸¹ Podobno sliko zarisujejo novomeške gomile (sl. 43),²⁸² kar napeljuje na misel, da je prišlo v zadnjih fazah pokopavanja do splošnega obubožanja halštatskih skupnosti na Dolenjskem ali do kakih drugih pretresov.

3.3.2 GROBOVI S KERAMIKO BREZ DRUGIH PRIDATKOV

Ob množici bronastih, železnih, steklenih in jantarnih predmetov so izkopavalci lončenino precej bolj zanemarjali, mnogokrat je sploh niso pobrali. V tem smislu je zgovorno dejstvo, da je bilo največ grobov z lončenino kot edinim pridatkom zabeleženih v gomilah 2 in 13 na Prelogah, ki ju je kopal Pečnik po navodilih Szombathyja za dunajski muzej (sl. 39). V gomili 2 je bilo takih grobov 11,8 %, v gomili 13 pa 17,6 %. Ob tem velja poudariti, da sta ti gomili vsebovali tudi najbogatejše grobove.

Po podatkih o velikosti okostij, ki jih je zapisal Brattina v svojem dnevniku, so v skupini grobov s keramiko kot edinim pridatkom zastopane tako odrasle osebe kot otroci. O otroškem okostju govori v zvezi z grobovoma 2/37 in 13/149 s Prelog, starost otroka v grobu 13/140 je označil z menjavo mlečnih zob, v grobovih 13/7, 13/11 in 13/172 pa naj bi bile pokopane mlade osebe. Skeleta v grobovih 13/71 in 13/115 sta menda merila 175 in 180 cm, kar kaže na odrasli osebi.²⁸³

Spekter posod, ki nastopa v tej skupini grobov, je različen. Grobovi iz gomile 2 na Prelogah so vsebovali po dve ali več posod. Med njimi najdemo celo grški *oinochoe* in *kylix* (2/37) iz južnoitalskih delavnic,²⁸⁴ situli z ного in barvanim okrasom (2/43), največkrat pa skodele ali sklede z ного in nagubanim ostenjem ter živalskimi aplikami na ročajih, pa tudi ciborije ter bučo in latvico.²⁸⁵ V grobovih te vrste iz gomile 13 na Prelogah pa nastopa le ena posoda, pogostokrat v črepinjah. Po

²⁸¹ Gabrovec et al. 2006, 55, 100, 104, 122, pril. 1; Gabrovec 2008, sl. 21 in 23.

²⁸² Knez 1986, 26, T. 62, 65; id. 1993, 55, pril. 2; Križ 1997, 18, 22, pril. 1 in 2; id. 2000, 18 s, pril. 2.

²⁸³ Glej tu poglavje 1.1.3, sl. 8. Za primerjavo naj omenim grob 48/159 iz Stične, ki vseboval le dva lonca. Antropološka analiza je pokazala, da je bila v njem pokopana oseba ženskega spola.

²⁸⁴ Frey 1969, 84; Kimmig 1974, 68; Kromer 1986, 6, Abb. 2: 1,2; Gabrovec 1992a, Abb. 13: 2,5; Teržan 1995b, 88, Abb. 13; Mihovilić 1995, 295.

²⁸⁵ Gr. 2/31–36, 2/44. Za tipologijo glej Dular J. 1982, 86, 142 ss, 155 s, sl. 26: 6, 27: 10–12, 28: 2–3 in T. 22: 197, 199, 23: 203,208, 25: 237.

of burial.²⁸¹ A similar observation can be made for the tumuli at Novo mesto (fig. 43),²⁸² which might point to a general pauperization of the Dolenjska communities or other perturbations in the last burials phases.

3.3.2 GRAVES WITH POTTERY AS THE ONLY GRAVE GOOD

Faced with a multitude of metal, glass and amber objects, excavators tended to neglect the pottery finds, often not collecting them at all. It is noteworthy in that respect that most burials with pottery as the only grave good were documented in Tumuli 2 and 13 at Preloge, excavated by Pečnik for the museum in Vienna according to Szombathy's instructions (fig. 39). Tumulus 2 revealed 11.8% such graves and Tumulus 13 revealed 17.6%; the two tumuli also revealed the richest graves at Magdalenska gora.

The sizes of the skeletons from these graves, as noted by Brattina in his diary, reveal adults as well as children. He speaks of a child's skeleton in connection with Graves 2/37 and 13/149 at Preloge, he marked the age of the child in Grave 13/140 as with falling deciduous teeth, while Graves 13/7, 13/11 and 13/172 reportedly contained young individuals. The skeletons in Graves 13/71 and 13/115 measured 175 and 180cm, respectively, which points to adult individuals.²⁸³

The range of vessels appearing in this group of graves varies. Graves from Tumulus 2 at Preloge contained two or more vessels. These include a Greek *oinochoe* and *kylix* (2/37) from south Italian workshops,²⁸⁴ two footed situlae with painted decoration in the form of triangles (2/43), but most often cups and footed bowls with indented walls and animal appliqué on the handles, as well as a gourd-like vessel and a bowl.²⁸⁵ Tumulus 13 at Preloge, on the other hand, revealed one vessel in such graves, often in shards. In type, these are either small jars or bowls with a knob,²⁸⁶ wide bowls

²⁸¹ Gabrovec et al. 2006, 55, 100, 104, 122, Beil. 1; Gabrovec 2008, Abb. 21 and 23

²⁸² Knez 1986, 26, T. 62, 65; id. 1993, 55, Beil. 2; Križ 1997, 18, 22, App. 1 and 2; id. 2000, 18 f, App. 2.

²⁸³ See here Chapter 1.1.3, fig. 8. For comparison see also Stična's Grave 48/159 with two jars only. The anthropological analysis of the human remains from this grave indicates a female burial.

²⁸⁴ Frey 1969, 84; Kimmig 1974, 68; Kromer 1986, 6, Abb. 2: 1,2; Gabrovec 1992a, Abb. 13: 2,5; Teržan 1995b, 88, Abb. 13; Mihovilić 1995, 295.

²⁸⁵ Gr. 2/31–36, 2/44. For comparison see Dular J. 1982, Abb. 26: 6, 27: 10–12, 28: 2–3 and T. 22: 197, 199, 23: 203,208, 25: 237.

²⁸⁶ Gr. 13/12, 13/74, 13/75, 13/103, 13/104.

zvrsti gre za lončke ali latvice s plastično bradavico,²⁸⁶ sklede z ali brez noge,²⁸⁷ lončke z vrezanim okrasom in vtisnjenimi pikami.²⁸⁸

Ta keramični zbir spominja na lončenino iz Dolenjskih Toplic, zato se na kratko dotaknimo topliške keramične produkcije. Nekropolo je analizirala Teržanova in pokazala, da največ pokopov spada v čas certoških fibul in negovskih čelad (sl. 44).²⁸⁹ Gomile je prekopal Pečnik za dunajski muzej v letih 1898 in 1899, se pravi pol desetletja zatem, ko si je izkušnje nabiral na Magdalenski gori. Največji delež pripada grobovom, kjer je bila lončenina edini pridatek (44 %). Med njimi prednjačijo lonci, ki so večinoma nekvalitetno žgani, površno izdelani in slabše modelirani, zato so dostikrat nesimetrične oblike. Običajno so okrašeni s plastičnimi aplikami različnih oblik (podkvaste oblike, bradavice, kolobarji, kačice, svastike, valovnice, rogljičaste nalepke) ali z vodoravnimi rebri in kanelurami. Zastopane so tudi sklede (navadne, z ного ali dvema ročajema), okrašene s plitkimi kanelurami, poševnim žlebljenjem, plastičnimi rebri in bradavicami ali nagubanim ostenjem. Nič manj pogosti niso ročati lončki, vrči, ročke in buče. Med slednjimi zasledimo okras z vrezanimi šrafiranimi trikotniki, cikcak vrezi in vtisnjenimi pikami. Ponavljajo se tudi zelo stare forme, kot so glinaste situle in latvice, najlepše izdelke pa predstavljajo kernosi, medtem ko so kvalitetno izdelani in lepo oblikovani ciboriji, ki krasijo dolenske halštatske grobove od stopnje Stična vse do negovskega časa, v Dolenjskih Toplicah izjemno redki.²⁹⁰ S posodjem se včasih pojavljajo tudi vijčki (16,3 %), kar govori za ženske pokope, redkeje v njih zasledimo kak značilen moški pridatek, kot je npr. brusni kamen (v 2,2 %).

Ob tem je v topliških gomilah opazen še drug pojav, to je znaten delež grobov z orožjem in pokopov brez pridatkov (sl. 44). Razmerje med grobovi z orožjem in brez je 3 : 2. V gomilah V, XI, XIII in XVI, kamor so pokopavali v času negovske stopnje, je precej več grobov z orožjem kot tistih z druge vrste pridatki. Ravno obratno sliko odražajo gomile, ki so nastale v predhodni (certoški) stopnji in v katere so na začetku negovske stopnje prenehali pokopavati (gomile II, VI in VII). Iz tega lahko postuliramo, da so bile v poznohalštatskem obdobju ženske oprave precej skromne, na drugi strani pa je opazno večje oboroževanje ali "militarizacija" družbe. V študiji o družbeni strukturi v dolenskem halštatskem krogu je Teržanova pokazala, da je bila v tistem času kar četrtina prebivalstva Dolenjskih Toplic in Magdalenske gore oboroženega.²⁹¹

²⁸⁶ Gr. 13/12, 13/74, 13/75, 13/103, 13/104.

²⁸⁷ Gr. 13/7, 13/39, 13/70, 13/89.

²⁸⁸ Gr. 13/11, 13/71.

²⁸⁹ Teržan 1976, 385 ss, T. 1–91.

²⁹⁰ Dular J. 1982, T. 6: 40, 7: 52,56,59,60, 8: 62,63,66,68,69, 9: 82,86, 10: 93,97–99, 20: 173, 24: 220,235, 26: 255.

²⁹¹ Teržan 1976, 442 ff; ead. 1985, Abb. 17; ead. 1995b, 81 ff; Abb. 3; ead. 1997, 661 f, Abb. 6.

with or without a foot,²⁸⁷ or small jars with grooved decoration and impressed dots.²⁸⁸

This ceramic assemblage is reminiscent of the pottery from Dolenjske Toplice, which will be briefly presented below. The cemetery at Dolenjske Toplice was analysed by Teržan, who showed that most burials date to the Certosa and Negova phases (fig. 44).²⁸⁹ Its tumuli were excavated by Pečnik for the museum in Vienna in 1898 and 1899, half a decade after gaining experience at Magdalenska gora. The greatest share of graves is those with pottery as the only good (44%). The commonest pottery form in these graves is a jar, mostly poorly fired, imprecisely made as well as carelessly modelled and thus often of unsymmetrical shape. No less frequent are small vessels with handles and small jugs. The usual decoration consists of appliques of various shapes or ribs and grooves, as well as knobs or indented walls. Very old forms also appear, such as clay situlae and bowls. The most beautiful products are kernoi, while the well made and beautifully modelled footed bowls that generally appear in the graves of Dolenjska from the Stična to the Negova phases are extremely rare at Dolenjske Toplice.²⁹⁰ Sometimes appearing alongside ceramic vessels are spindle whorls (16.3%), which indicate female burials, less frequent are characteristic male attributes, such as a whetstone (in 2.2% of graves).

The tumuli of Dolenjske Toplice also revealed a significant share of graves with weapons and burials without grave goods (fig. 44). The ratio between graves with and those without weapons is 3 : 2. Tumuli V, XI, XIII and XVI revealed significantly more graves with weapons than those with other grave goods. Teržan showed that these were late tumuli, where burial took place in the Negova phase. The opposite was documented in tumuli from the previous, Certosa phase, where burials ceased in the beginning of the Negova phase (Tumuli II, VI and VII). This postulates that in the Late Hallstatt period female costumes were rather modest, on the one hand, and the presence of arms and the "militarization" of society increased, on the other. In her study on the social structure in the Hallstatt circle of Dolenjska, Teržan showed that as much as a fourth of the inhabitants of Dolenjske Toplice and Magdalenska gora was armed.²⁹¹

Pertinent and revealing as to the above is the structure of graves in Tumulus V at Magdalenska gora (fig. 39), which was formed in the Late Hallstatt period and reached its peak in the Negova phase.²⁹² It contained

²⁸⁷ Gr. 13/7, 13/39, 13/70, 13/89.

²⁸⁸ Gr. 13/11, 13/71.

²⁸⁹ Teržan 1976, 438 ff, T. 1–91

²⁹⁰ Dular J. 1982, T. 6: 40, 7: 52,56,59,60, 8: 62,63,66,68,69, 9: 82,86, 10: 93,97–99, 20: 173, 24: 220,235, 26: 255.

²⁹¹ Teržan 1976, 442 ff; ead. 1985, Abb. 17; ead. 1995b, 81 ff; Abb. 3; ead. 1997, 661 f, Abb. 6.

²⁹² Tecco Hvala/Dular/Kocuvan 2004, Abb. 50A.

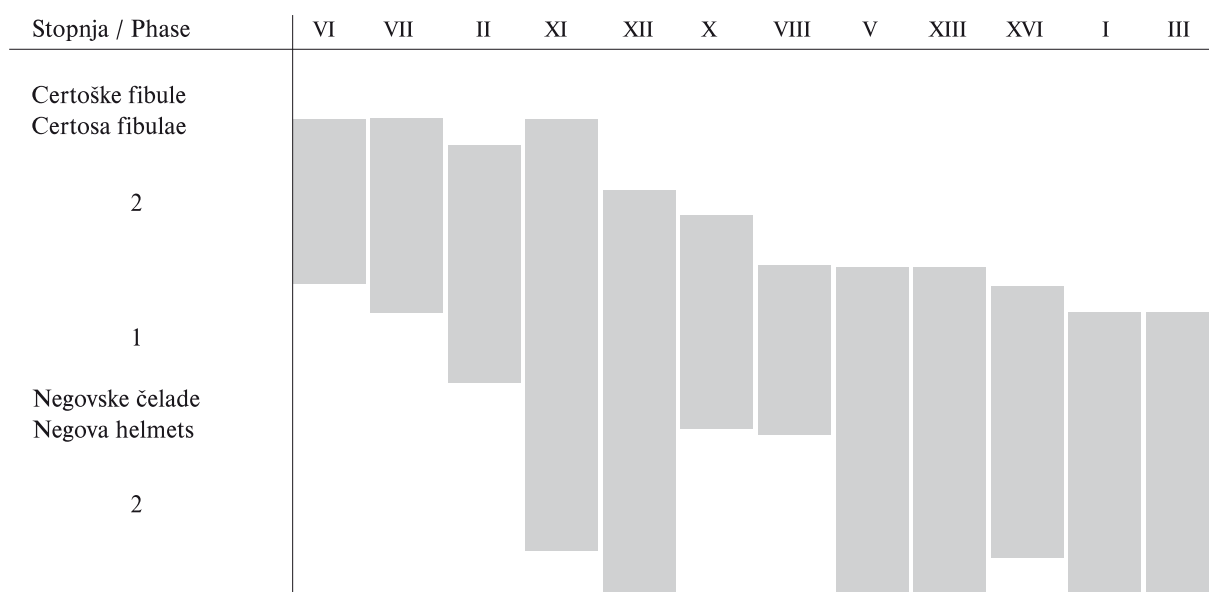

Gomila Tumulus	Pokop / Burial rite skeletni skeletal	Št. grobov / No. of graves			
		brez pridatkov no gr. goods	samo z lončenino only pottery	z orožjem with weapon	brez orožja no weapon
I	12	-	5	3	4
II	43	-	20	9	14
III	9	-	4	4	1
IV	3	1	-	1	1
V	47	-	22	16	9
VI	17	1	7	2	7
VII	19	2	7	4	6
VIII	24	6	11	4	3
IX	4	-	2	1	1
X	10	-	3	4	3
XI	25	-	6	14	5
XII	13	-	4	5	4
XIII	22	-	12	8	2
XIV	6	-	6	-	-
XV	16	1	9	3	3
XVI	23	-	9	12	2
XVII	9	-	8	-	1
Skupaj Total	302	11 (4 %)	135 (44 %)	90 (30 %)	66 (22 %)

Sl. 44: Časovni razpon in struktura pokopov v gomilah v Dolenjskih Toplicah (po Teržanovi 1976, sl. 58).

Fig. 44: Chronological span and structure of burials in tumuli at Dolenjske Toplice (after Teržan 1976, Abb. 58).

Na Magdalenski gori je v tem smislu izpovedna struktura grobov v gomili V na Laščiku (sl. 39), ki je nastala v mlajšem halštatskem obdobju in dosegla vrh v negovskem času,²⁹² v njej pa je imelo orožje kar 48 % grobov. To težnjo v oboroževanju je na Magdalenski gori moč razbrati tudi iz kronološke slike, prikazane v drugem poglavju (sl. 10), kjer je negovska stopnja predstavljena pretežno z bojvniškimi grobovi, medtem ko so ženski pokopi tistega časa precej slabše zastopani.

48% of graves with weapons, 33% with other goods and 19% without goods. This militarizing tendency can also be discerned from the chronological scheme (fig. 10), which reveals a significant share of warrior graves in the Negova phase.

An overview of inhumation graves without grave goods and those where only pottery was found can be summarized in the following findings:

²⁹² Tecco Hvala/Dular/Kocuvan 2004, sl. 50A.

Pregled skeletnih grobov brez pridatkov in tistih, ki so bili opremljeni samo z lončenino, lahko strnemo v naslednje ugotovitve:

- pojavljajo se skorajda v vseh gomilah, tako v tistih z bogatimi pokopi kot tudi v revnejših, kar pomeni, da ni šlo zgolj za socialno razlikovanje med posameznimi družinami in klani;

- med njimi so zastopani tako moški kot ženske in otroci, torej niso vezani zgolj na eno spolno ali starostno skupino;

- velikokrat jih zasledimo na robu gomile in v vrhnjih plasteh, iz česar bi na osnovi stiškega modela nastanka gomile lahko sklepali, da gre za najmlajše pokope.

Zdi se, da so pokopi brez pridatkov ali samo s keramiko ter povečan delež grobov z orožjem odraz kriznih razmer in družbene preobrazbe v poznohalštatskem obdobju. Za razjasnitev tega problema bodo potrebna nadaljnja preverjanja,²⁹³ zlasti strukture novomeške nekropole, ki je še v teku raziskav. Že zdaj pa lahko rečemo, da so tudi tam v nekaterih gomilah prevladovali grobovi s keramiko kot edinim pridatkom. Taka je npr. gomila 3 na Znančevih njivah, ki je po kronološko indikativnih pridatkih sodeč precej mlada; v njej je bilo tovrstnih grobov več kot polovica, hkrati pa je vsebovala precej bogate pokope iz certoške in zgodnje negovske stopnje (3/1, 3/2, 3/3, 3/24 in 3/33). Še večji delež grobov s keramiko kot edinim pridatkom je zastopan v gomilah A in B na Kapiteljski njivi, ki ju je ob koncu poletja 1894 prekopal Pečnik za dunajski muzej, večidel v sodelovanju z bratom muzejskega arheologa in profesorja za prazgodovinsko arheologijo Hoernesa, nazadnje pa s preparatorjem Brattino. Pečnik je bil menda nad bero zelo razočaran, zato sta se z Brattino odpravila na Magdalensko goro, kjer sta se lotila gomile 13 na Prelogah.²⁹⁴

3.3.3 GROBOVI Z OROŽJEM IN NAKITOM

V skupinski sliki magdalenskogorskih gomil predstavljajo grobovi z orožjem 21-odstotni delež (žgani in skeletni skupaj), grobovi z druge vrste pridatki (brez tistih, ki so vsebovali samo keramiko) pa 41-odstotni delež. Na splošno razkrivajo zelo bogat in raznolik inventar, ki bo v nadaljevanju podrobneje predstavljen. Posamične zvrsti predmetov in grobne celote so bile že obravnavane v okviru raznih tipoloških in kronoloških

²⁹³ Gotovo to ni edina možna razlaga, saj so pokopi brez pridatkov, ki bi se trajneje ohranili, zastopani v žarnogrobiščnih nekropolah (Teržan 1995a, 339 ss, Abb. 11; ead. 1999, 138 s, Fig. 9a) in v številnih gomilah iz starejše železne dobe na Dolenjskem (Teržan 1985, 77, sl. 16: neuporabni), zatorej bi jih lahko razumeli tudi kot fenomen družbene razslojenosti.

²⁹⁴ Knez 1986, 39 ss in 83 ss, T. 23–28 in T. 45–51.

- these graves were found in almost all tumuli, both in those with rich burials as well as in poorer tumuli, which speaks against a social differentiation among individual families or clans;

- the graves contained males and females as well as children, which speaks against them being linked to a particular sex or age group;

- the graves were often found on the perimeters of tumuli or in their upper layers, which would, on the basis of the model from Stična, lead to the assumption of them representing the latest burials within a tumulus.

At this point, it seems that graves without goods or only with pottery as well as a higher share of graves with weapons reflect a crisis and a social transformation in the Late Hallstatt period. Further verification is needed,²⁹³ however, to confirm this observation, particularly of the structure of the cemetery at Novo mesto. The latter is currently under research, though it can already be said that, there as well, graves with pottery as the only grave good were prevalent in some of the tumuli. One such is Tumulus 3 at Znančeve njive, which is relatively late according to the chronologically indicative data; more than half its graves were with pottery only, though it also contained rather rich graves from the Certosa and Early Negova phases (3/1, 3/2, 3/3, 3/24 and 3/33). An even greater share of graves with pottery only was found in Tumuli A and B at Kapiteljska njiva, dug by Pečnik at the end of the summer of 1894 for the museum in Vienna, mostly in cooperation with the brother of Hoernes, the museum's archaeologist and professor for prehistoric archaeology, and towards the end with the museum technician Brattina. Pečnik was reportedly very disappointed at the yield, wherefore he and Brattina headed to Magdalenska gora, to Tumulus 13 at Preloge.²⁹⁴

3.3.3 GRAVES WITH WEAPONS AND JEWELLERY

In an overall view of the tumuli at Magdalenska gora, the graves with weapons (cremation and inhumation) represent a 21 per cent share, while the graves with other graves goods (excluding those with pottery only) represent a 41 per cent share. The graves in general reveal a very varied contents, which will be discussed in greater detail below. Individual types of objects and grave groups have already been treated within various typological

²⁹³ Such an explanation does not represent the only possibility. Burials without durable grave goods are testified in cemeteries of Urnfield periods (Teržan 1995a, 339 ss, Abb. 11; ead. 1999, 114 f, Fig. 9a) as well as in tumuli from the Early Iron Age in Dolenjska (Teržan 1985, 99, Abb. 16: unberücksichtigt), so they can be also interpreted as a phenomenon of social stratification.

²⁹⁴ Knez 1986, 39 ff and 83 ff, T. 23–28, 45–51.

študij, prav tako nekatere značilne kombinacije v smislu prepoznavanja noše in njihovih nosilcev, zato bom poskušala doseganja spoznanja strniti in jih nadgraditi s primerjalno analizo količinskih razmerij v okviru najdišč dolenskega halštatskega kroga. Cilj te analize je usmerjen v vrednotenje tipičnih prvin lokalne noše in njenih posebnosti. Pri tem upoštevam način pokopa in lego grobov ter kombinacije predmetov, v katerih se pojavljajo, pa tudi njihov časovni razpon in geografsko razširjenost.

and chronological studies, as were certain characteristic combinations in terms of identification of costume and its bearers; for this reason I shall first attempt to summarize the findings thus far and then to supplement them with a comparative analysis of quantitative relations within the scope of the Dolenjska circle. This analysis is aimed at evaluating the characteristic elements of the local costume and its particularities, which takes into account the burial rite and position of graves, as well as the chronological range and geographic distribution of individual elements.

4 OPRAVE

4 OUTFIT

Od oprav železnodobnih prebivalcev Magdalenske gore so se ohranili nakitni predmeti, orožje in orodje ter razne insignije in pripomočki, ki jih v nadaljevanju obravnavam po posameznih zvrsteh.

4.1 OROŽJE

Od napadalnega orožja so zastopani sulice, kopja, sekire, noži, puščične osti, nekaj bodal in mečev, od obrambnega orožja pa čelade. V gomilah so mestoma naleteli tudi na pokope z orožjem iz poznolatenskega obdobja, ki so vsebovali ščite, vendar jih v nadaljnje analize ne vključujem, ker so ti konteksti kontaminirani in zaradi premajhnega števila niso reprezentativni.²⁹⁵

4.1.1 SEKIRE

Sekire se pojavljajo v več kot polovici grobov z orožjem (*sl. 45: B*). Velikokrat predstavljajo edini kos orožja, najpogosteje pa jih zasledimo v kombinaciji s parom sulic ali le z eno sulično ostjo, k tem opravam pa je bil včasih dodan še nož.

Vsi magdalenskogorski primerki sekir so železni. Med njimi prevladuje tulast tip z ušescem ali brez (*sl. 45: A in sl. 46: 3–14*), razen teh lahko naštejemo še 23 uhatih sekir (*sl. 46: 15–20*), 14 primerkov z enostranskimi plavutmi (*sl. 46: 21–26*), eno sekiro z dvostranskimi plavutmi (*sl. 46: 1*) ter eno križno sekiro (*sl. 46: 2*).

KRIŽNE SEKIRE

Ena ploščata križno oblikovana železna sekira je objavljena med dodatki groba IV/43 s Preloge (*sl. 46: 2*), ki je označen tudi kot Konjski grob IV. Okostje konja je analiziral Bököny in ga uvrstil v vzhodno skupino (skitskih) konj (*sl. 3*), medtem ko človeške kosti niso omenjene. Objavljeno grobno celoto sestavljajo pred-

²⁹⁵ Laščík, *gr. V/5, V/10, V/42; Preloge, gr. 2/5, 2/12, 2/41, 2/45, 2/49, 2/71, X/64*.

The Iron Age inhabitants of Magdalenska gora were accompanied in their graves by various worldly possessions, such as pieces of jewellery, weapons and implements, but also various insignia and several other items. These are discussed below according to type.

4.1 WEAPONS

The finds of arms from Magdalenska gora consist of spears, javelins, axes, arrows, several daggers and swords, while of the armour only the helmets are represent. Also unearthed were a few burials with shields from the Late La Tène period. The graves of the Late Iron Age, however, are not included in the analysis as their contexts are contaminated and their number unrepresentative.²⁹⁵

4.1.1 AXES

Axes appear in more than half of the documented graves with weapons (*fig. 45: B*). They often represent the only piece of armament, though they most often appear in combination with either a pair or a single spearhead, a knife sometimes being added.

All examples of axes found at Magdalenska gora are made of iron. The predominant type is a socketed axe with or without a loop (*fig. 45: A and fig. 46: 3–14*). There is also more than twenty shaft-hole axes (*fig. 46: 15–20*), fourteen one-sided winged axes (*fig. 46: 21–26*), as well as one winged (*fig. 46: 1*) and one lugged axe (*fig. 46: 2*).

LUGGED AXE

One iron lugged axe (*Ärmchenbeile*) was published as part of Grave IV/43 at Preloge (*fig. 46: 2*), also marked as Horse Grave IV. The horse skeleton was analysed by Bökönyi, who placed it within the eastern group of (Scythian) horses (*fig. 3*). Sources do not mention hu-

²⁹⁵ Laščík, *Gr. V/5, V/10, V/42; Preloge, Gr. 2/5, 2/12, 2/41, 2/45, 2/49, 2/71, X/64*.

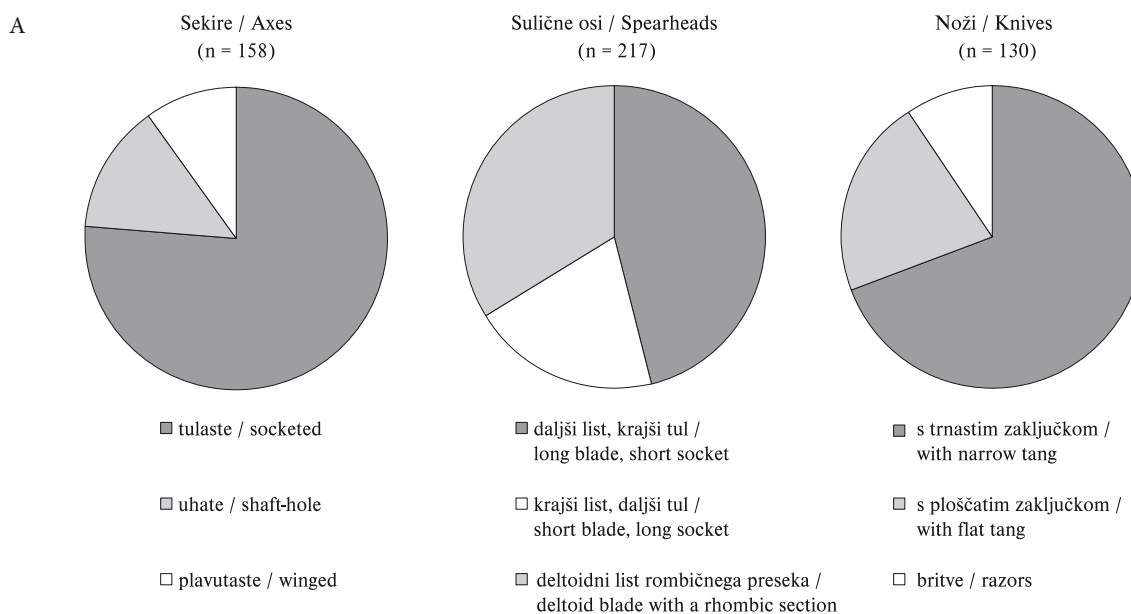

B

Sekira Axe	Sulica Spear	Nož Knife	Kompleti orožja po posameznih gomilah Sets of weapons in individual tumuli										Skupaj Total
			II	IV	V	VI	VII	VIII	X	P2	P13	V2	
1				6	6		4		3	5	6		30 (16 %)
1		1	1	1		2	1		2	2	1		10 (5 %)
1	1	1				1	1		1	2	3		8 (4 %)
1	1			1	1		4	1	4	5	4	2	22 (12 %)
1	2	1			1	1	1	1	5	6	3		18 (10 %)
1	2			1	1	3			1	7	2		15 (8 %)
	2	1	1	2	2	2		1			1		9 (5 %)
	2		1	1	1				1	3	2		9 (5 %)
	1	1		1	5		3	2	1	1	4		17 (9 %)
	1			3	4		1	1	1	2	4	1	17 (9 %)
		1		4	3		1	1	6		15	3	33 (17 %)

Sl. 45: A – deleži posameznih vrst orožja na Magdalenski gori; B – kompleti orožja po posameznih gomilah (n = število kompletov).
Fig. 45: A – shares of individual weapon types from Magdalenska gora; B – sets of weapons in individual tumuli (n = number of sets).

meti iz Mecklenburške zbirke in iz zbirke Narodnega muzeja v Ljubljani. Poleg križne sekire so vanjo vključeni dve sulični osti, nož, dvokrilna in triroba puščična ost, kačasta fibula s sedlastim lokom in druga s široko trakasto zanko, bronasta pravokotna pasna spona ter železno žezlo z bronasto kapico. Te predmete hrani Narodni muzej v Ljubljani, iz Peabodyjevega muzeja pa so pridružene še ena kačasta fibula s trakasto zanko, železna tulasta sekira, par bronastih derez, okrasni gumbki za jermenje in dve glinasti situli. Hencken je pripomnil, da je predmetov, pripisanih temu grobu, več, kot jih je zabeležil Goldberg, ki navaja le eno sekiro, dve posodi in ostanke tkanine ali usnjene jermena.²⁹⁶

Križna sekira je edini primerek te vrste z Magdalenske gore. Na območju dolenske skupnosti so znane

man bones. The grave group, as published, consists of objects from the Mecklenburg Collection and from the collection of the National Museum of Slovenia. Apart from the axe, it includes two spearheads, a knife, a bilobate and a trilobate arrowhead, two serpentine fibulae, a bronze rectangular belt clasp and an iron mace with a bronze head, all from the National Museum, as well as another serpentine fibula, iron socketed axe, pair of bronze crampons, decorative horse-gear strap fittings and two clay situlae, kept at the Peabody Museum. Having said that, Hencken noted that more goods were ascribed to this grave than reported by Goldberg, who only mentioned an axe, two vessels and remains of cloth or leather from the harness.²⁹⁶

The lugged axe is the only example of its type at Magdalenska gora. In Dolenska, they were also found

²⁹⁶ Hencken 1978, 25 s, Fig. 85p.

²⁹⁶ Hencken 1978, 25 f, Fig. 85p.

iz Stične,²⁹⁷ Novega mesta,²⁹⁸ Vač,²⁹⁹ iz okolice Velikega Vinjega vrha (Šmarjete),³⁰⁰ iz Lutrškega sela, Velikih Malenc³⁰¹ in z Budinjaka.³⁰² Širok časovni razpon njihove uporabe najbolje ponazarjata grobova s Kapiteljske njive v Novem mestu, kjer jo zasledimo v grobu 1/16 iz časa stopnje Podzemelj 2 ter v grobu 7/19 iz negovske stopnje. V Stični nastopa v grobu 48/72 iz stopnje Stična 1.³⁰³ Gre za pokope konjenikov, ki so imeli še drugo sekiro drugačnega tipa – bronasto z dvostranskimi plavutmi³⁰⁴ ali železno tulasto.³⁰⁵

Železne križne sekire so bile predmet mnogih razprav.³⁰⁶ Podrobneje jih je preučila Anke Wesse in pokazala na prostranost njihovega pojavljanja.³⁰⁷ Razločila je več oblikovnih različic,³⁰⁸ magdalenskogorski primerek je opredelila kot varianto III 1 A,2 z najožjimi paralelami v Slavoniji (Kaptol), v Porabju (Somlyóhegy, Somlyóvásárhely, Vaszar-Pőrösret) ter na Slovaškem (Vinné).³⁰⁹ Ta različica spada v skupino III 1, ki je zastopana na območju vzhodnih Alp s središčem v Hallstattu, kjer so bile v uporabi vse halštatsko obdobje, medtem ko se na območju Karpatске kotline in centralnega Balkana pojavijo že prej.³¹⁰

SEKIRE Z DVOSTRANSKIMI PLAVUTMI

V zapuščini magdalenskogorske skupnosti nastopa železen primerek sekire z dvostranskimi plavutmi (sl. 46: 1). Pripadal je žganemu grobu s kamnito skrinjo na Laščiku (12/1), ki je dozdevno predstavljal edini pokop v gomili na skrajnem severnem robu nekropole.³¹¹ Tudi drugod na Dolenjskem so maloštevilne. Trije primerki

²⁹⁷ Gabrovec et al. 1994, T. 12: 17; Gabrovec et al. 2006, T. 39: 29, 189: 21.

²⁹⁸ Knez 1993, T. 18: 5; Egg 1999, Abb. 10: 14.

²⁹⁹ Neobjavljeno, NHMW inv. št. 8007 in en primerek brez inv. št.

³⁰⁰ Stare V. 1973a, T. 10: 3.

³⁰¹ Guštin 1996, Abb. 6: 4.

³⁰² Škoberne 1999, 31, op. 66, sl. 23: desno zgoraj.

³⁰³ Gabrovec et al. 2006, T. 39: 29; id. 2008, 49 s; Teržan 2008, 280 s.

³⁰⁴ *Novo mesto-Kapiteljska njiva, gr. 1/16*: Knez 1993, T. 18: 6.

³⁰⁵ *Stična, gr. 48/72*: Gabrovec et al. 2006, T. 39: 30; *Novo mesto-Kapiteljska njiva, gr. 7/19*: Egg 1999, Abb. 8: 1.

³⁰⁶ Mayer 1977, 235 ss; Stary 1982, 41, Abb. 5, Liste 5; Wesse 1990; Parzinger/Nekvasil/Barth 1995, 60; Tomedi 2002, 120 ss.

³⁰⁷ Wesse 1990, Karte 1.

³⁰⁸ *Ibid.*, Karte 17.

³⁰⁹ *Ibid.*, 76 s, 150 ss, 199, Kat. št. 134, T. 25.

³¹⁰ *Ibid.*, 175 s, Karte 19.

³¹¹ Tecco Hvala/Dular/Kocuvan 2004, 24, sl. 12, 18, T. 6B: 4.

at Stična,²⁹⁷ Novo mesto,²⁹⁸ Vače,²⁹⁹ near Veliki Vinji vrh (Šmarjeta),³⁰⁰ at Lutrško selo, Velike Malence³⁰¹ and Budinjak.³⁰² They enjoyed a long use, which is best illustrated by two graves with such axes from Kapiteljska njiva at Novo mesto: Grave 1/16 dates to the Podzemelj 2 and Grave 7/19 to the Negova phase. At Stična, a lugged axe was found in Grave 48/72 from the Stična 1 phase.³⁰³ All the graves with such axes were burials of horsemen and contained a second axe of a different type – either a bronze winged³⁰⁴ or an iron socketed axe.³⁰⁵

Iron lugged axes were featured in numerous discussions.³⁰⁶ They were studied in more detail by Anke Wesse, who showed their widespread appearance.³⁰⁷ She distinguished between several variants,³⁰⁸ determining the example from Magdalenska gora as Variant III 1 A,2 with closest parallels in Slavonia (Kaptol), the Raab basin (Somlyóhegy, Somlyóvásárhely, Vaszar-Pőrösret) and Slovakia (Vinné).³⁰⁹ The variant forms part of Group III 1, which is represented in the area of the eastern Alps with the centre at Hallstatt. It was in use there throughout the Hallstatt period, while in the Carpathian basin and the central Balkans it appeared earlier.³¹⁰

WINGED AXE

The iron winged axe (*fig. 46: 1*) is another unique example within the Magdalenska gora material. It was found in a cremation cist grave at Laščik (12/1), which supposedly represented the only burial within a tumulus on the northernmost edge of the cemetery.³¹¹ It is a rare find also elsewhere in Dolenjska; three are known from

²⁹⁷ Gabrovec et al. 1994, T. 12: 17; Gabrovec et al. 2006, T. 39: 29, 189: 21.

²⁹⁸ Knez 1993, T. 18: 5; Egg 1999, Abb. 10: 14.

²⁹⁹ Unpublished, NHMW Inv. No. 8007 and another example without an Inv. No.

³⁰⁰ Stare V. 1973a, T. 10: 3.

³⁰¹ Guštin 1996, Abb. 6: 4.

³⁰² Škoberne 1999, 31, n. 66, Fig. 23: top right.

³⁰³ Gabrovec et al. 2006, T. 39: 29; id. 2008, 49 f; Teržan 2008, 280 f.

³⁰⁴ *Novo mesto-Kapiteljska njiva, Gr. 1/16*: Knez 1993, T. 18: 6.

³⁰⁵ *Stična, Gr. 48/72*: Gabrovec et al. 2006, T. 39: 30; *Novo mesto-Kapiteljska njiva, Gr. 7/19*: Egg 1999, Abb. 8: 1.

³⁰⁶ Mayer 1977, 235 ff; Stary 1982, 41, Abb. 5, Liste 5; Wesse 1990; Parzinger/Nekvasil/Barth 1995, 60; Tomedi 2002, 120 ff.

³⁰⁷ Wesse 1990, Karte 1.

³⁰⁸ *Ibid.*, Karte 17.

³⁰⁹ *Ibid.*, 76 f, 150 ff, 199, Kat. Nr. 134, T. 25.

³¹⁰ *Ibid.*, 175 f, Karte 19.

³¹¹ Tecco Hvala/Dular/Kocuvan 2004, 24, Abb. 12, 18, T. 6B: 4.

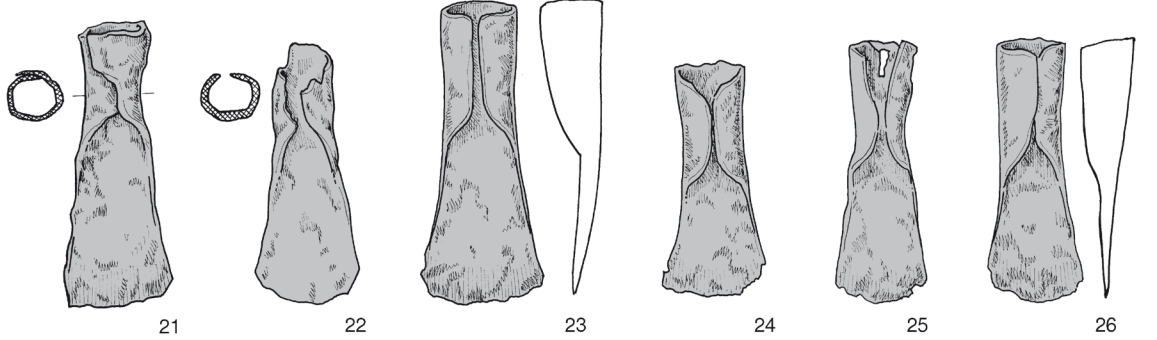
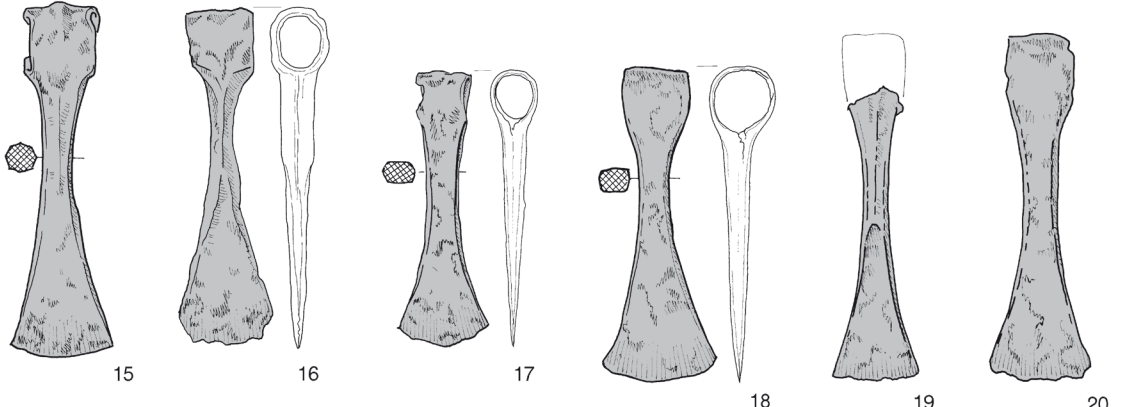
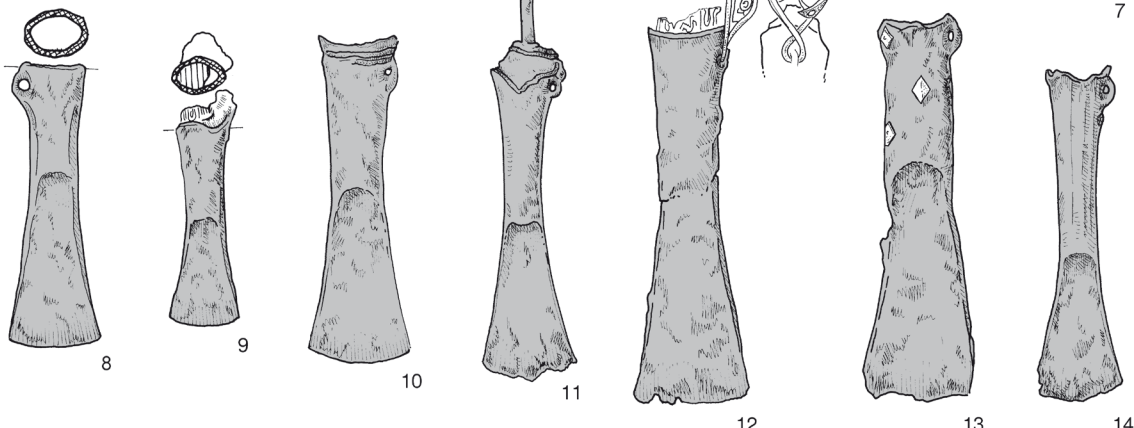
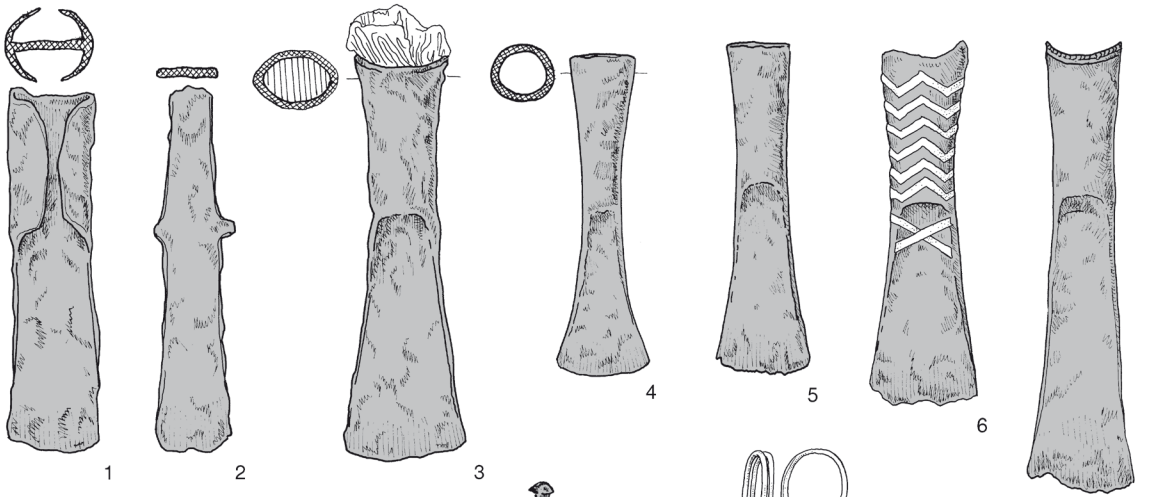

so znani iz Stične,³¹² po dva z Vač³¹³ in Libne³¹⁴ ter po eden iz Velikih Malenc³¹⁵ in Sajevc.³¹⁶ V Sajevcah je bila najdena v grobu 9/2 iz časa stopnje Podzemelj,³¹⁷ medtem ko v grobnem sestavu V/18 iz Stične, ki izvira z izkopavanja vojvodinje Mecklenburške, nastopa skupaj s slabo ohranjeno dvogrebenasto čelado in bronastim kotličkom.³¹⁸

Predhodnice železnih sekir z dvostranskimi plavutmi lahko slutimo v bronastih prototipih z visoko stoječimi plavutmi, ki se v jugovzhodnih Alpah pojavljajo v času Ha B / Ha C.³¹⁹ Take sekire so bile najdene v Ljubljani v strugi Ljubljani³²⁰ in v žarnem grobišču v grobu 39, ki je datiran v stopnjo Ljubljana Ila.³²¹ Srečamo jih v Podzemlju,³²² na Tolstem vrhu pod Gorjanci,³²³ Velikem Vinjem vrhu oz. Šmarjeti³²⁴ ter v Novem mestu na Kapiteljski njivi v grobu 1/16, ki je vodilni predstavnik stopnje Podzemelj 2.³²⁵

Železni primerki plavutastih sekir so znani na koroškem najdišču Breg / Frög v stopnji Frög 3 (= Podzemelj 2),³²⁶ v štajerskem Kleinkleinu so zastopani v fazi 2.³²⁷ V ta čas bi lahko postavili tudi magdalenskogorski grob 12/1 z Laščika, kar bi pomenilo, da gre za sploh najstarejšo sekiro na tem najdišču. Ta grobni sestav odraža še druge podobnosti s Kleinkleinom, kjer se v fazah 2

Stična,³¹² two from Vače,³¹³ two from Libna³¹⁴ and one from Velike Malence³¹⁵ and Sajevce.³¹⁶ At the latter site, the axe was found in Grave 9/2 and dates to the Podzemelj phase,³¹⁷ while it was found together with a poorly preserved double-crested helmet and a bronze cauldron in Grave V/18 from Stična, excavated by the Duchess of Mecklenburg.³¹⁸

The predecessor of the iron axes with bilateral wings can be seen in the bronze prototypes with high wings, which appear in the south-eastern Alps in Ha B / Ha C.³¹⁹ Such axes were found in Ljubljana, more precisely in the riverbed of the Ljubljana³²⁰ and urn Grave 39 from Phase Ljubljana Ila of the Urnfield culture cemetery.³²¹ Further ones were found at Podzemelj,³²² Tolsti vrh below the Gorjanci Hills,³²³ Veliki Vinji vrh (Šmarjeta)³²⁴ and in Novo mesto, in Grave 1/16 at Kapiteljska njiva, the latter being the leading representative of the Podzemelj 2 phase.³²⁵

Iron examples of winged axes were also found at Frög in Carinthia, dating to the Phase 3 (= Podzemelj 2),³²⁶ and at Kleinklein, Styria, where they are represented in Phase 2.³²⁷ Grave 12/1 at Laščik could also be set in this phase, which would make the axe

³¹² Wells 1981, Fig. 128a; Gabrovec et al. 2006, T. 148: 26, 163: 61.

³¹³ Neobjavljeno, NHMW inv. št. 6487, 8480.

³¹⁴ Guštin 1976, T. 33: 5, 75: 11.

³¹⁵ Stare V. 1960–1961, T. 5: 1.

³¹⁶ Guštin/Preložnik 2005, sl. 14: 17.

³¹⁷ *Ibid.*, 124, 131 ss.

³¹⁸ Wells 1981, 71, Fig. 128a.

³¹⁹ Mayer 1977, 167 ss; Stary 1982, 36 s, Abb. 2, Liste 2; Dobiat 1980, 143, 168, T. 3: 2, 34: 13, 49: 3, 107: 2, A1: 14; Strmčnik Gulič 1979, 121, T. 19: 1; Tomanič-Jevremov 1988–1989, 292, T. 18: 4; Teržan 1990a, 24, 115, 137, T. 69: 1,2, 78: 18, 83: 8; Šinkovec 1995, T. 11–13; Tomedi 2002, 116 ss, T. 1A: 1, 44A: 30, 44B: 32, 59: 1, 74D: 2, 85C: 2, 86A: 2, 86B: 2, 87A: 1, 96D: 1.

³²⁰ Šinkovec 1995, 57 s, Kat. št. 73, 74.

³²¹ Stare F. 1954b, T. 35: 1; Gabrovec 1973, 343, razpredelnica 1; Teržan 1987, 7, Fig. 1: 15.

³²² Barth 1969, T. 21: 1.

³²³ Šinkovec 1995, 56, Kat. št. 69.

³²⁴ Stare V. 1973a, T. 10: 1,2.

³²⁵ Knez 1993, T. 18: 6.

³²⁶ Tomedi 2002, 119, T. 5A: 1, 66B: 2, 84: 13, 96A: 1, 96C: 1.

³²⁷ Dobiat 1980, 143, T. 22: 12, 69: 9, 99: 4.

³¹² Wells 1981, Fig. 128a; Gabrovec et al. 2006, T. 148: 26, 163: 61.

³¹³ Unpublished, NHMW Inv. Nos. 6487, 8480.

³¹⁴ Guštin 1976, T. 33: 5, 75: 11.

³¹⁵ Stare V. 1960–1961, T. 5: 1.

³¹⁶ Guštin/Preložnik 2005, Fig. 14: 17.

³¹⁷ *Ibid.*, 124, 131 ff.

³¹⁸ Wells 1981, 71, Fig. 128a.

³¹⁹ Mayer 1977, 167 ff; Stary 1982, 36 f, Abb. 2, Liste 2; Dobiat 1980, 143, 168, T. 3: 2, 34: 13, 49: 3, 107: 2, A1: 14; Strmčnik Gulič 1979, 121, T. 19: 1; Tomanič-Jevremov 1988–1989, 292, T. 18: 4; Teržan 1990a, 24, 115, 137, T. 69: 1,2, 78: 18, 83: 8; Šinkovec 1995, T. 11–13; Tomedi 2002, 116 ff, T. 1A: 1, 44A: 30, 44B: 32, 59: 1, 74D: 2, 85C: 2, 86A: 2, 86B: 2, 87A: 1, 96D: 1.

³²⁰ Šinkovec 1995, 57 f, Cat. Nos. 73, 74.

³²¹ Stare F. 1954b, T. 35: 1; Gabrovec 1973, 343, Table 1; Teržan 1987, 7, Fig. 1: 15.

³²² Barth 1969, T. 21: 1.

³²³ Šinkovec 1995, 56, Cat. No. 69.

³²⁴ Stare V. 1973a, T. 10: 1,2.

³²⁵ Knez 1993, T. 18: 6.

³²⁶ Tomedi 2002, 119, T. 5A: 1, 66B: 2, 84: 13, 96A: 1, 96C: 1.

³²⁷ Dobiat 1980, 143, T. 22: 12, 69: 9, 99: 4.

Sl. 46: Tipi železnih sekir z Magdalenske gore. 1 – sekira z dvostranskimi plavutmi, 2 – križna sekira, 3–14 – tulaste sekire, 15–20 – uhate sekire, 21–26 – sekire z enostranskimi plavutmi. M. = 1:4.

Fig. 46: Types of iron axes from Magdalenska gora. 1 – winged axe, 2 – lugged axe, 3–14 – socketed axes, 15–20 – shaft-hole axes, 21–26 – one-sided winged axes. Scale = 1:4.

1 – Laščik, gr. 12/1; 2 – gr. IV/3; 3 – gr. 2/58; 4 – gr. 2/46; 5 – gr. X/76; 6 – gr. IV/21; 7 – gr. IV/43; 8 – gr. 13/55; 9 – gr. 13/114; 10 – gr. X/23; 11 – gr. X/21; 12 – gr. VII/44; 13 – gr. VI/22; 14 – gr. X/64; 15 – gr. 13/60; 16 – gr. 2/6; 17, 18 – najdbi brez znanih grobnih celot v NMS / finds without preserved contexts; 19 – Preloge, Tum. VII; 20 – gr. VII/15; 21 – gr. 2/69; 22 – gr. 2/49; 23 – gr. V/8; 24 – gr. VII/11; 25 – gr. VII/23; 26 – gr. X/64.

in 3 pojavljajo enake grobne konstrukcije iz kamnitih plošč ter podobni ciboriji.³²⁸ Po drugi strani ga lahko primerjamo z Bregom / Frögom; tudi tam so izpričani pokop v kamnito skrinjo in podobne železne dereze, kot jih je imel magdalenskogorski predstavnik iz omenjenega groba 12/1.³²⁹ Na Gorenjskem, Notranjskem in v Posočju se železne sekire z dvostranskimi plavutmi pojavljajo v mlajših kontekstih.³³⁰ V začetku mlajšega halštatskega obdobja lahko zasledimo tudi bronaste izvedbe plavutastih sekir, ki imajo ušesce ali izrastek na temenu (Teržanova jih je označila za tip Most na Soči).³³¹

TULASTE SEKIRE

Med magdalenskogorskimi najdbami lahko naštejemo skupno 119 železnih tulastih sekir (sl. 46: 3–14).³³² Največ (19 primerkov v 17 grobovih) jih je bilo najdenih v gomili 2 na Prelogah. K tem bi lahko prišteli še 11 kosov brez ohranjenih grobnih celot v zbirki Narodnega muzeja³³³ ter pet primerkov, ki so v privatni lasti.³³⁴

Nekatere sekire imajo na robu tula okras (sl. 46: 7, 10)³³⁵ ali pa je tul fasetiran (sl. 46: 14),³³⁶ medtem ko sta sekiri iz grobov IV/21 in VI/22 s Prelog okrašeni z bronastimi aplikami oz. tavširanjem (sl. 46: 6, 13).³³⁷

³²⁸ Tum. Leitengritschwald 27: Dobiat 1980, 249 s, T. 99: 1-3,6, Beil. 4.

³²⁹ Tomedi 2002, 536 ss, T. 10A: 5.

³³⁰ V Kranju jo zasledimo v grobu bojavnika skupaj s certoškima fibulama vrste IV (Stare F. 1954d, T. 3: 1); več primerkov je zastopanih v depozu Tržišče iz stopnje Notranjska III, tj. čas stopnje Stična na Dolenjskem (Guštin 1973, 473; id. 1979, T. 32: 12-14 in različice z ušescem na temenu, podobne bronastemu tipu Most na Soči: T. 31: 6-8); v Posočju so znane z *Mosta na Soči* in *Kobarida* (Marchesetti 1981, T. 18: 15; id. 1993, T. 28: 4), v *Idriji pri Bači*, *Reki pri Cerknem* in *Bodrežu* pa se pojavljajo grobovih iz mlajše železne dobe (Guštin 1991, T. 2: 3, 15: 5, 26: 2, 34: 3, 38: 1).

³³¹ Teržan 1990a, 110, 141, op. 564, karta 24.

³³² Hencken 1978, Fig. 26b, 39a, 44c, 47b, 52a, 53c, 54, 57f, 63m, 77a, 79a, 83b, 84a, 91a, 117h, 129g, 133c, 151a, 153a, 155, 156b, 170e, 186g, 191g, 196c, 206d, 212e, 213e, 215b, 223c, 228b, 231b, 232e, 236b, 238a, 243a, 259g, 265a, 272c, 280d, 281e, 288b, 290a, 292b, 296b,c, 305a, 307c, 310, 312f, 314c, 317i, 320a, 323h, 324, 336d, 337e, 341j, 343f, 344, 350n, 351a, 360f; Tecco Hvala/Dular/Kocuvan 2004, T. 16: 20,21, 17A: 4, 17C: 1, 26: 25, 29A: 5,6, 31A: 5; 36: 25, 39A: 9, 42: 11, 45: 16, 47B: 3, 48A: 3, 52: 22, 53: 5, 56: 22, 60B: 11, 61B: 6, 64: 19, 66C: 3, 72A: 6, 74B: 4, 82C: 5, 84: 13, 86D: 4, 88B: 3, 89B: 1, 93B: 1, 96D: 1, 103C: 6, 109: 12, 110A: 3, 113B: 11, 115B: 7, 139C: 2, 140A: 4, 165: 4,7-9, 167: 1-7.

³³³ Tecco Hvala/Dular/Kocuvan 2004, T. 165: 4,7-9, 167: 1-7.

³³⁴ Švajncer 2012, 9 ss.

³³⁵ Hencken 1978, Fig. 77a, 84a, 129g, 314c, 317i, 344; Tecco Hvala/Dular/Kocuvan 2004, T. 110A: 3.

³³⁶ Hencken 1978, Fig. 77a, 206d, 350n.

³³⁷ *Ibid.*, Fig. 57f, 196c.

the earliest at the site. The grave group shows other similarities with Kleinklein, where the same stone cists and footed bowls appear in Phases 2 and 3.³²⁸ It could also be paralleled with Frög; where stone cist burial and similar crampons as those in Grave 12/1 were documented.³²⁹ In Gorenjska, Notranjska and the Soča Valley, iron winged axes appear in later contexts.³³⁰ The earliest bronze examples of winged axes with a loop or a lug on the butt can be traced at the beginning of the Late Hallstatt period (marked by Teržan as Type Most na Soči).³³¹

SOCKETED AXES

The finds from Magdalenska gora include 119 iron axes of this type (fig. 46: 3–14).³³² The greatest number of them came from Tumulus 2 at Preloge, more precisely 19 axes from 17 graves. There are further 11 axes without known grave provenance kept at the National Museum of Slovenia³³³ and five privately owned axes.³³⁴

Some axes have a decorated socket rim (fig. 46: 7, 10)³³⁵ or a faceted socket (fig. 46: 14).³³⁶ The axes from Graves IV/21 and VI/22 at Preloge even have either inlaid or bronze appliqué decoration (fig. 46: 6, 13).³³⁷

³²⁸ Tum. Leitengritschwald 27: Dobiat 1980, 249 f, T. 99: 1-3,6, Beil. 4.

³²⁹ Tomedi 2002, 536 ff, T. 10A: 5.

³³⁰ In Kranj, one example was found in combination with a Type IV Certosa fibula in a warrior's grave (Stare F. 1954d, T. 3: 1). Several examples belong to the hoard from Tržišče dated to the Notranjska III = Stična phase in Dolenjska (Guštin 1973, 473; id. 1979, T. 32: 12-14, and the variant with a loop or a lug on the butt resembles Type Most na Soči: T. 31: 6-8). They are known also from *Most na Soči* and *Kobarida* (Marchesetti 1981, T. 18: 15; id. 1993, T. 28: 4), while at *Idrija pri Bači*, *Reka pri Cerknem* and *Bodrež* they appear in graves from the Late Iron Age (Guštin 1991, T. 2: 3, 15: 5, 26: 2, 34: 3, 38: 1).

³³¹ Teržan 1990a, 110, 141, n. 564, map 24.

³³² Hencken 1978, Figs. 26b, 39a, 44c, 47b, 52a, 53c, 54, 57f, 63m, 77a, 79a, 83b, 84a, 91a, 117h, 129g, 133c, 151a, 153a, 155, 156b, 170e, 186g, 191g, 196c, 206d, 212e, 213e, 215b, 223c, 228b, 231b, 232e, 236b, 238a, 243a, 259g, 265a, 272c, 280d, 281e, 288b, 290a, 292b, 296b,c, 305a, 307c, 310, 312f, 314c, 317i, 320a, 323h, 324, 336d, 337e, 341j, 343f, 344, 350n, 351a, 360f; Tecco Hvala/Dular/Kocuvan 2004, T. 16: 20,21, 17A: 4, 17C: 1, 26: 25, 29A: 5,6, 31A: 5; 36: 25, 39A: 9, 42: 11, 45: 16, 47B: 3, 48A: 3, 52: 22, 53: 5, 56: 22, 60B: 11, 61B: 6, 64: 19, 66C: 3, 72A: 6, 74B: 4, 82C: 5, 84: 13, 86D: 4, 88B: 3, 89B: 1, 93B: 1, 96D: 1, 103C: 6, 109: 12, 110A: 3, 113B: 11, 115B: 7, 139C: 2, 140A: 4, 165: 4,7-9, 167: 1-7.

³³³ Tecco Hvala/Dular/Kocuvan 2004, T. 165: 4,7-9, 167: 1-7.

³³⁴ Švajncer 2012, 9 ff.

³³⁵ Hencken 1978, Figs. 77a, 84a, 129g, 314c, 317i, 344; Tecco Hvala/Dular/Kocuvan 2004, T. 110A: 3.

³³⁶ Hencken 1978, Figs. 77a, 206d, 350n.

³³⁷ *Ibid.*, Figs. 57f, 196c.

Med kronološko izpovednimi grobnimi celotami bi bila najstarejša IV/3 s Prelog, kjer se taka sekira pojavlja v kombinaciji s sestavljeno čelado. V stopnjo kačastih fibul lahko zanesljivo uvrstimo grobne sestave 2/57, 2/58, VII/39 iz gomil na Prelogah, še več jih lahko opredelimo v certoško stopnjo³³⁸ in v čas negovskih čelad.³³⁹

Železne sekire s tulom okroglega preseka za nasaditev na toporišče je kot poseben tip izpostavil že Peter Stary v razpravi o halštatskih sekirah v alpskem svetu;³⁴⁰ njegov seznam zbranih primerkov je moč dopolniti z najdbami, ki so bile objavljene zatem.³⁴¹

Najstarejši kontekst s tako sekiro na Dolenjskem, ki nakazuje njihov pojav v času stopnje Podzemelj 2, predstavlja centralni grob v gomili 48 iz Stične, ki je vseboval italško konjsko opremo.³⁴² Ta tip sekire je v Stični zabeležen še skupaj s skledasto čelado v sklopu grobnih celot VI/13 in X/11 iz Mecklenburške zbirke,³⁴³ toda ta kombinacija je precej nenavadna, saj se drugod s skledasto čelado pojavljajo drugi tipi sekir (križne in plavutaste) ter meči.³⁴⁴ Zagotovo pa je železna tulasta sekira pripadala inventarju groba 48/72 iz Stične s trakokimerijsko konjsko opremo ter grobu iz gomile 76 z bronastim figuralno okrašenim pokrovom in uvoženim *oinochoe*;³⁴⁵ ta dva pokopa sta datirana v stopnjo Stična. V tem času jo na Magdalenski gori in na Vačah srečamo v kombinaciji s sestavljeno čelado,³⁴⁶ medtem ko je bila v Podzemlju najdena skupaj z veliko čolničasto fibulo.³⁴⁷

³³⁸ Preloge, gr. 2/13, 2/38, 2/46, 2/47, 13/55, 13/119.

³³⁹ Preloge, gr. 2/3, 13/63, 13/64; Voselca, gr. 2/23.

³⁴⁰ Stary 1982, 38 s, Abb. 4, Liste 4. Primerke iz Dobrniča je pomotoma uvrstil na seznam uhatih sekir, kjer slednje sploh niso izpričane.

³⁴¹ Brezovo: Dular J. 2003, T. 62: 7; Dobrnič: Stare V. 1973b, T. 3: 1-4,6, 4: 1-4, 9: 4,5, 10: 3,4,7,8, 12: 6; Parzinger 1988-1989, 1: 10; Novo mesto: Križ 1997, T. 21: 4, 33: 4, 36: 3,4, 41: 4, 54: 2(?); id. 2000, T. 3: 7, 42: 4; Egg 1999, Abb. 8: 1, 9: 1; Kaplja vas: Dular J. 2003, T. 83: 5; Kremenska hosta pri Bistrici: *ibid.*, T. 12: 2; Pance: *ibid.*, T. 2: 2; Podturn: *ibid.*, T. 24: 8, 25: 1; Rihpovec: *ibid.*, T. 30: 1, 31: 6, 35: 3; Roje pri Trebelnem: *ibid.*, T. 28: 5; Rovišče: *ibid.*, T. 68: 2, 78: 3, 79: 2; Sajenice: *ibid.*, T. 5: 8; Slančji vrh: *ibid.*, T. 86: 9; Stična: Wells 1981, Figs. 57b, 70e, 72a, 95a, 125b, 127a, 144h, 153, 179; Gabrovec et al. 2006, T. 6: 5, 13: 37, 27: 9, 32: 9, 39: 39, 57: 14,15, 62: 7, 81: 3, 107: 8, 114: 4, 122: 8, 124: 8, 131: 3, 141: 33; 143: 11, 163: 62, 165: 12, 171: 60; 180: 192-196; 181: 197; 193: 1; Suhadole: Dular J. 2003, T. 90: 5; Veliki Vinji vrh (Šmarjeta): Dular A. 1991, T. 18: 6-8, 19: 4,5; 31: 12-15, 32: 5, 35: 9,12, 36: 23, 40: 17, 43: 3,4; Zagorica pri Čatežu: Dular J. 2003, T. 38: 10, 39: 4.

³⁴² Gabrovec et al. 2006, T. 13: 37; id. 2008, 47 s; Teržan 2008, 277 s.

³⁴³ Wells 1981, 75, 84, Fig. 144g, 181a. Glej še Teržan 2008, 194 ss, sl. 4 in 6.

³⁴⁴ Škoberne 1999, sl. 68. Skledasto čelado je po mnenju Teržanove vsebovala tudi gomila Ofenmacherwald 48 v Kleinklenu, kjer je zastopana še železna plavutasta sekira (Teržan 1990a, 138).

³⁴⁵ Gabrovec et al. 2006, T. 39: 39, 131: 3.

³⁴⁶ Gabrovec 1960b, sl. 10: 2, 11: 6; id. 1965-1966, T. 1: 2.

³⁴⁷ Podzemelj-Škrilje, gr. 2/14: Barth 1969, 156 s, T. 36: 2.

The earliest of the chronologically revealing grave groups is IV/3 from Preloge, where a socketed axe appears in combination with a composite helmet. Grave Groups 2/57, 2/58 and VII/39 from the tumuli at Preloge can be dated to the Serpentine Fibulae phase, while even more socketed axes date to the Certosa³³⁸ and Negova phases.³³⁹

Iron axes with a socket of a round cross-section were marked as a special type already by Peter Stary in his discussion on Hallstatt axes in the Alpine world.³⁴⁰ His list can now be updated by the finds published afterwards.³⁴¹

The earliest context that includes a socketed axe in Dolenjska is the central grave with Italic horse gear in Tumulus 48 at Stična.³⁴² This grave indicates their appearance in the Podzemelj 2 phase. The axe type was further found at Stična alongside a bowl-shaped helmet in Grave Groups VI/13 and X/11 from the Mecklenburg Collection,³⁴³ though this is a rather unusual combination, since bowl-shaped helmets appear elsewhere with lugged or winged types of axes or with a sword.³⁴⁴ An iron socketed axe was certainly found in Grave 48/72 at Stična with Thraco-Cimmerian horse gear, and in a grave from Tumulus 76 with a bronze lid with figural decoration and an imported *oinochoe*;³⁴⁵ both dated to the Stična phase. At this time, the socketed axe appears at Magdalenska gora and Vače in combination with the composite helmet,³⁴⁶ while at Podzemelj it was found together with a large boat fibula.³⁴⁷ In the Late Hallstatt

³³⁸ Preloge, Gr. 2/13, 2/38, 2/46, 2/47, 13/55, 13/119.

³³⁹ Preloge, Gr. 2/3, 13/63, 13/64; Voselca, Gr. 2/23.

³⁴⁰ Stary 1982, 38 f, Abb. 4, Liste 4. He wrongly included the examples of this type from Dobrnič into the list of shaft-hole axes; the latter type is not attested at that site.

³⁴¹ Brezovo: Dular J. 2003, T. 62: 7; Dobrnič: Stare V. 1973b, T. 3: 1-4,6, 4: 1-4, 9: 4,5, 10: 3,4,7,8, 12: 6; Parzinger 1988-1989, 1: 10; Novo mesto: Križ 1997, T. 21: 4, 33: 4, 36: 3,4, 41: 4, 54: 2(?); id. 2000, T. 3: 7, 42: 4; Egg 1999, Abb. 8: 1, 9: 1; Kaplja vas: Dular J. 2003, T. 83: 5; Kremenska hosta pri Bistrici: *ibid.*, T. 12: 2; Pance: *ibid.*, T. 2: 2; Podturn: *ibid.*, T. 24: 8, 25: 1; Rihpovec: *ibid.*, T. 30: 1, 31: 6, 35: 3; Roje pri Trebelnem: *ibid.*, T. 28: 5; Rovišče: *ibid.*, T. 68: 2, 78: 3, 79: 2; Sajenice: *ibid.*, T. 5: 8; Slančji vrh: *ibid.*, T. 86: 9; Stična: Wells 1981, Figs. 57b, 70e, 72a, 95a, 125b, 127a, 144h, 153, 179; Gabrovec et al. 2006, T. 6: 5, 13: 37, 27: 9, 32: 9, 39: 39, 57: 14,15, 62: 7, 81: 3, 107: 8, 114: 4, 122: 8, 124: 8, 131: 3, 141: 33; 143: 11, 163: 62, 165: 12, 171: 60; 180: 192-196; 181: 197; 193: 1; Suhadole: Dular J. 2003, T. 90: 5; Veliki Vinji vrh (Šmarjeta): Dular A. 1991, T. 18: 6-8, 19: 4,5; 31: 12-15, 32: 5, 35: 9,12, 36: 23, 40: 17, 43: 3,4; Zagorica pri Čatežu: Dular J. 2003, T. 38: 10, 39: 4.

³⁴² Gabrovec et al. 2006, T. 13: 37; id. 2008, 47 f; Teržan 2008, 277 f.

³⁴³ Wells 1981, 75, 84, Figs. 144g, 181a. See also Teržan 2008, 194 ff, Abb. 4, 6.

³⁴⁴ Škoberne 1999, Fig. 68. After Teržan, Tumulus Ofenmacherwald 48 at Kleinklein also contained one bowl-shaped helmet, found together with an iron winged axe (Teržan 1990a, 138).

³⁴⁵ Gabrovec et al. 2006, T. 39: 39, 131: 3.

³⁴⁶ Gabrovec 1960b, Abb. 10: 2, 11: 6; id. 1965-1966, T. 1: 2.

³⁴⁷ Podzemelj-Škrilje, Gr. 2/14: Barth 1969, 156 f, T. 36: 2.

V mlajšem halštatskem obdobju so železne tulaste sekire predstavljale standardno oborožitev dolenskih bojevnikov, zlasti v stopnjah kačastih in certoških fibul, ko drugih oblik skorajda ni opaziti. Iz tistega časa so ob tulastih sekirah znani le posamični primerki t. i. skitoidnih sekir (iz okolice Ljubljane, Vač, Volčjih Njiv in Libne), ki imajo izvor v poznohalštatski kulturni skupini Vekerzug.³⁴⁸ Grobna celota V/18 iz Stične s kombinacijo železne sekire z dvostranskimi plavutmi in dvogrebenaste čelade je prav tako neobičajna,³⁴⁹ saj se ta tip čelade drugod povezuje s tulasto sekiro. Da se je tulasti tip sekire obdržal vse do izteka halštatskega obdobja, pa pričajo grobni sestavi iz Dolenskih Toplic³⁵⁰ in Novega mesta.³⁵¹

Izven teritorija dolenske skupnosti so zabeležene na Ljubljanskem barju (v strugi Ljubljanice pri Bevkah),³⁵² v svetolucijskem krogu, na Notranjskem (depo Tržišče), na Koroškem, Štajerskem, Solnograškem ter v Býčí skáli; posamezni primerki so segli tudi dlje v zahodnopanonski in centralnobalkanski prostor.³⁵³

O okrasu na tulastih sekirah

En primerek železne tulaste sekire z Magdalenske gore je okrašen z bronastimi rombičnimi aplikami (sl. 46: 13); objavljen je v sklopu groba VI/22 s Prelog, ki je predstavljal žgani pokop – grobno jamo s pepelom in sežganimi kostmi je prekrivala majhna kamnita plošča, med prdatke pa sta poleg sekire spadala še bronast obroček in železen nož.³⁵⁴ Drug okrašen primerek (sl. 46: 6) je bil najden v skeletnem grobu IV/21 s Prelog skupaj z dvema sulicama (ena ima enak tavširan okras). Sulični osti naj bi bili prvotno vtaknjeni v železni tulec, zraven naj bi spadali še nož in železna pravokotna pasna spona ter certoška fibula, ki je pogrešana.³⁵⁵ S tavširanimi bronastimi trakovi sta okrašeni tudi sulici iz groba

³⁴⁸ Vače: Stare F. 1955a, T. 12: 1,2; Volčje Njive, gr. 20: Gabrovec 1956, T. 17: 1; Teržan 1976, 384, sl. 54: 29; Libna, Volavškova gom./gr. d: Guštin 1976, T. 60: 5; Rob pri Ljubljani: Párducz 1973, Karte 2; Guštin/Teržan 1975, 191, op. 36; Egg 1978, 111 ss, Abb. 2 in 5; Stary 1982, 45, Abb. 8, Liste 8; Parzinger/Nekvasil/Barth 1995, 66, T. 29: 314,315; Kemenczei 2009, T. 4: 6, 11: 7, 13: 12, 20: 1–4 itd.

³⁴⁹ Wells 1981, 71, Fig. 128a. Možno je, da so grobne celote V/18, VI/13, X/11 z izkopavanj vojvodinje Meckleburške v Stični zamešane.

³⁵⁰ Dolenske Toplice, gr. 1/7, 5/17: Teržan 1976, T. 2: 1, 31: 1.

³⁵¹ Znančeve njive, gr. 4/3: Knez 1986, T. 34: 7; Kapiteljska njiva, gr. 7/19: Egg 1999, Abb. 8: 1, 9: 1.

³⁵² Turk et al. (ur.) 2009, 218, Kat. št. 26b–d.

³⁵³ Dopolnjene karte razprostranjenosti po Staryju 1982 so objavili: Parzinger/Nekvasil/Barth 1995, 68 s, Abb. 23, T. 30: 317; Egg 1996, Abb. 91; Guggisberg/Stöllner 1996, 125 s, Abb. 6.

³⁵⁴ Hencken 1978, 46, Fig. 196c.

³⁵⁵ Ibid., 20 s, Fig. 57.

period, iron socketed axes represent the standard weapon of the Dolenska warrior. This is particularly true of the Serpentine and Certosa Fibulae phases, when other types are almost unrepresented. Only sporadic examples of the so-called Scythoid axes were found (vicinity of Ljubljana, Vače, Volčje Njive and Libna), the origin of which is to be sought in the cultural group of Vekerzug.³⁴⁸ Grave Group V/18 from Stična with a winged axe and a double-crested helmet represents another exceptional combination, since this helmet type appears elsewhere with socketed axes.³⁴⁹ The socketed axe remained in use until the end of the Hallstatt period, as evidenced by grave groups from Dolenske Toplice³⁵⁰ and Novo mesto.³⁵¹

Outside the territory of the Dolenska community, socketed axes were documented on the Ljubljansko barje (in the Ljubljanica riverbed at Bevke),³⁵² within the Sveta Lucija circle, in Notranjska (the Tržišče hoard), Carinthia / Koroška, Styria / Štajerska, Salzburg and Býčí skála; individual items also penetrated into the west Pannonian and Central Balkan regions.³⁵³

On the decoration of the socketed axes

One iron socketed axe from Magdalenska gora is decorated with bronze rhomboid appliqué (fig. 46: 13). It was published as part of cremation Grave VI/22 at Preloge. The grave pit with ashes and cremated remains was covered by a small slab and its grave goods further included a bronze ring and an iron knife.³⁵⁴ Another decorated axe (fig. 46: 6) was found in inhumation Grave IV/21 at Preloge together with two spears (one with matching inlaid decoration). The spearheads had supposedly been inserted into a sheath with an iron chape and found together with a knife and an iron rectangular belt clasp as well as a Certosa fibula, the latter now missing.³⁵⁵ The decoration of inlaid bronze bands was documented on

³⁴⁸ Vače: Stare F. 1955a, T. 12: 1,2; Volčje Njive, Gr. 20: Gabrovec 1956, T. 17: 1; Teržan 1976, 384, Abb. 54: 29; Libna, Tum. Volavšek./Gr. d: Guštin 1976, T. 60: 5; Rob near Ljubljana: Párducz 1973, Karte 2; Guštin/Teržan 1975, 191, n. 36; Egg 1978, 111 ff, Abb. 2, 5; Stary 1982, 45, Abb. 8, Liste 8; Parzinger/Nekvasil/Barth 1995, 66, T. 29: 314,315; Kemenczei 2009, T. 4: 6, 11: 7, 13: 12, 20: 1–4 etc.

³⁴⁹ Wells 1981, 71, Fig. 128a. It is possible that Grave Groups V/18, VI/13, X/11 from the excavations by the Duchess of Mecklenburg at Stična are jumbled up.

³⁵⁰ Dolenske Toplice, Gr. 1/7, 5/17: Teržan 1976, T. 2: 1, 31: 1.

³⁵¹ Znančeve njive, Gr. 4/3: Knez 1986, T. 34: 7; Kapiteljska njiva, Gr. 7/19: Egg 1999, Abb. 8: 1, 9: 1.

³⁵² Turk et al. (eds.) 2009, 218, Cat. No. 26b–d.

³⁵³ Distribution map published by Stary in 1982 was later supplemented by Parzinger/Nekvasil/Barth 1995, 68 f, Abb. 23, T. 30: 317; Egg 1996, Abb. 91; Guggisberg/Stöllner 1996, 125 f, Abb. 6.

³⁵⁴ Hencken 1978, 46, Fig. 196c.

³⁵⁵ Ibid., 20 f, Fig. 57.

1/31 z Znančevih njiv v Novem mestu, kjer nastopata v kombinaciji s certoškima fibulama vrste V.³⁵⁶ Toda tavširan okras se na območju južnih in vzhodnih Alp pojavi že prej. Z zlatimi nitkami ali bronastimi trakovi so okrašene nekatere železne tulaste sekire iz časa stopnje Podzemelj 2, npr. iz Stične,³⁵⁷ Brega / Fröga³⁵⁸ ali Hallstatta.³⁵⁹ Iz Notranjske izvira primerek, ornameniran z bronastimi trakovi in zoomorfnima aplikama.³⁶⁰ V zvezi s to dekorativno tehniko je morda umestno omeniti še ženski grob z zlatim diademom iz Sajevc na Dolenjskem, ki je datiran v stopnjo Stična 1. Vseboval je med drugim železno zapestnico s sledovi bronastega traku,³⁶¹ ki bi jo lahko primerjali z železnim torkvezom, ovitim z bronastim trakom, iz Montedinove v Picenumu.³⁶² Okraševanje železnih predmetov z bakrenimi ali bronastimi vložki je bilo razširjeno v srednji Italiji v obdobju *orientalizzante*, obdržalo pa se je še v 5. st. pr. n. št.³⁶³ V času Ha D1–D3 so podobno tehniko okraševanja uporabljali tudi na severnoalpskem prostoru.³⁶⁴

Sekire s fasetiranim tulom (*sl. 46: 14*) je zbral Markus Egg v študiji groba s kulturnim vozičkom iz Strettwega, v katerem nastopa bronasta različica.³⁶⁵ Na Magdalenski gori so zabeleženi trije železni primerki s fasetiranim tulom, med spremnimi najdbami pa se pojavljajo nož s ploščatim nastavkom za ročaj, sekira z enostranskimi plavutmi, svinčena narokvica in certoška fibula vrste X, ki govorijo za čas negovske stopnje.³⁶⁶ Sočasen jim je tudi grobni sestav s tako sekiro iz Brezja.³⁶⁷ Egg je mednje uvrstil še sekiro iz stiškega groba 48/72,³⁶⁸ ki spada v stopnjo Stična, vendar ta nima fasetiranega tula, temveč le dva rahla vodoravna žlebička pod robom.³⁶⁹

Vdolbljen linijski okras zasledimo na sekiri z Vač v grobu s sestavljeno čelado³⁷⁰ ter na nekaterih magdalenskogorskih primerkih (*sl. 46: 10*) iz certoške in negovske

³⁵⁶ Knez 1986, T. 9: 14,15.

³⁵⁷ *Gomila 48/centralni grob*: Gabrovec et al. 2006, T. 13: 37; Teržan 2008, 277, op. 212.

³⁵⁸ *Gomila 70(= K)/gr. 1*: Tomedi 2002, T. 42: 6. Enaka tehnika je uporabljena tudi pri konjski opremi iz tega groba (*ibid.*, T. 42: 7,8).

³⁵⁹ *Gr. 28/1939*: Kromer 1959b, T. 207: 1; Mayer 1977, 249 ss, T. 104: 1515.

³⁶⁰ *Šmihel pod Nanosom*: Knific/Nabergoj/Trampuž 1997, 268, sl. 41; Guštin 2007, 14, Fig. 8, Kat. št. 50.

³⁶¹ *Sajeve, gr. 10/1*: Guštin/Preložnik 2005, 143, sl. 6: 3.

³⁶² Lucentini 1992, 469, Fig. 4: 2; Kruta Poppi 1995, Fig. 4.

³⁶³ Sgubini Moretti 1992, 184, Fig. 10b; Lucentini 1992, 486 s, op. 68; *Eroi e regine. Piceni Popolo d'Europa* 2001, 111, Fig. 87 in Cat. Nr. 162.

³⁶⁴ Egg 1985b, 329 ss, Abb. 7.

³⁶⁵ *Id.* 1996, 151 ss, Abb. 87: 1, 88, 89: 1, 90.

³⁶⁶ *Preloge, gr. IV/36, VI/32, X/64*.

³⁶⁷ *Gr. 1/4*: Kromer 1959a, T. 2: 6.

³⁶⁸ Egg 1996, 151 ss.

³⁶⁹ Gabrovec et al. 2006, T. 39: 30.

³⁷⁰ Gabrovec 1965–1966, T. 2: 1.

two spears from Grave 1/31 at Znančeve njive in Novo mesto, appearing in combination with a pair of Type V Certosa fibulae.³⁵⁶ These objects, however, are not the first in the area of southern and eastern Alps to bear inlaid decoration. Gold threads or bronze bands were used to decorate several iron socketed axes from the Podzemelj 2 phase, for example axes from Stična,³⁵⁷ Frög³⁵⁸ and Hallstatt.³⁵⁹ One example from the Notranjska region was decorated with bronze bands and two zoomorphic appliquéés.³⁶⁰ Worth mentioning in connection with this decorative technique is a burial of a female with a golden diadem from Sajeve in Dolenjska, dated to the Stična 1 phase. This grave further revealed an iron bracelet with traces of a bronze band,³⁶¹ which could be paralleled with an iron torques banded with a bronze ribbon, from Montedinova in Picenum.³⁶² Decorating iron objects with bronze or copper inlays was widespread in central Italy in the *orientalizzante* period and survived into the fifth century BC.³⁶³ In Ha D1–D3, a similar decorative technique was also used in the northern Alpine area.³⁶⁴

Axes with a faceted socket (*fig. 46: 14*) were treated by Egg in his study of the grave with the cult wagon from Strettweg, where a bronze variant had been found.³⁶⁵ He lists three iron examples of this type from Magdalenska gora, appearing together with a knife with a flat tang, a one-sided winged axe, a lead armlet and a Type X Certosa fibula, all of which speak for the Negova phase.³⁶⁶ Contemporary to these is the grave group with such an axe from Brezje.³⁶⁷ Egg also listed the axe from Grave 48/72 at Stična,³⁶⁸ from the Stična phase, though the socket on this example is not faceted, but rather has two shallow parallel grooves under the rim.³⁶⁹

Decoration of incised lines can be seen on the axe from Vače, found in a grave with a composite helmet,³⁷⁰ as well as on several examples from Magdalenska gora (*fig. 46: 10*), dating to the Certosa and Negova phas-

³⁵⁶ Knez 1986, T. 9: 14,15.

³⁵⁷ *Tumulus 48/Central grave*: Gabrovec et al. 2006, T. 13: 37; Teržan 2008, 277, n. 212.

³⁵⁸ *Tumulus 70(= K)/Gr. 1*: Tomedi 2002, T. 42: 6. The same technique was used on the horse gear from this grave (*ibid.*, T. 42: 7,8).

³⁵⁹ *Gr. 28/1939*: Kromer 1959b, T. 207: 1; Mayer 1977, 249 ff, T. 104: 1515.

³⁶⁰ *Šmihel pod Nanosom*: Knific/Nabergoj/Trampuž 1997, 268, Fig. 41; Guštin 2007, 14, Fig. 8, Cat. No. 50.

³⁶¹ *Sajeve, Gr. 10/1*: Guštin/Preložnik 2005, 143, Fig. 6: 3.

³⁶² Lucentini 1992, 469, Fig. 4: 2; Kruta Poppi 1995, Fig. 4.

³⁶³ Sgubini Moretti 1992, 184, Fig. 10b; Lucentini 1992, 486 f, n. 68; *Eroi e regine. Piceni Popolo d'Europa* 2001, 111, Fig. 87 and Cat. No. 162.

³⁶⁴ Egg 1985b, 329 ff, Abb. 7.

³⁶⁵ *Id.* 1996, 151 ff, Abb. 87: 1, 88, 89: 1, 90.

³⁶⁶ *Preloge, Gr. IV/36, VI/32, X/64*.

³⁶⁷ *Gr. 1/4*: Kromer 1959a, T. 2: 6.

³⁶⁸ Egg 1996, 151 ff.

³⁶⁹ Gabrovec et al. 2006, T. 39: 30.

³⁷⁰ Gabrovec 1965–1966, T. 2: 1.

stopnje.³⁷¹ Na prvi pogled se torej zdi, da različni načini okraševanja nimajo kronoloških konotacij.

SEKIRE Z ENOSTRANSKIMI PLAVUTMI

Večina tovrstnih železnih sekir z Magdalenske gore (sl. 46: 21–26) izvira z izkopavanj vojvodinje Mecklenburške.³⁷² Iz opisov grobov s takimi sekirami je moč razbrati, da so ležali precej plitvo v gomilah: grob VII/11 s Prelog je ležal 35 cm pod površjem, zelo plitvo je menda ležal tudi grob VII/23; v zvezi z grobom VI/39 s Prelog, ki je med drugim vseboval bronasto predrto pasno spono, je Goldberg zapisal, da sta bili sekira (tulasta) in "kopača" (plavutasta) odkriti 30 cm pod površjem na skrajnem vzhodnem robu gomile in okoli pol metra nad grobom s to oznako. V gomili X na Prelogah so na njenem skrajnem jugovzhodnem robu in le 25 cm pod rušo naleteli na grob X/64, v katerem naj bi bil pokopan visok mlad moški z alpskimi potezami,³⁷³ ki je imel sekiro z enostranskimi plavutmi in še eno tulastega tipa ter eno majhno in dve ozki sulični osti, certoško fibulo vrste X, svinčeno narokvico in nož s ploščatim nastavkom in zakovicami. S plavutasto sekiro je bil opremljen tudi pokojnik v grobu IV/58, ki pa ga je Angel opredelil za mladega odraslega moškega z gracilnimi mediteranskimi potezami (sl. 6).³⁷⁴

V gomili, ki jo je kopala vojvodinja Mecklenburška na Laščiku, srečamo ta tip sekire med pridatki groba V/19–20, v katerem je bilo odkritih dvoje slabo ohranjenih okostij, med njima so bili položeni meč, dve dolgi sulični osti in ena sekira. Zraven je objavljena še uhata sekira iz zbirke Narodnega muzeja v Ljubljani, ki je Goldberg ne omenja.

S Pečnikovega kopanja gomile 2 na Prelogah so zabeležene tri grobne celote s takimi sekirami ter ena posamična najdba. V grobu 2/69 naj bi jo našli skupaj s sulično ostjo, dvema nožema, živalskim zobom in parom lepih certoških fibul, ki manjkata. V grobovih 2/41 in 2/49 pa nastopa s poznolatskimi prvinami, kot sta železni umbo ter udarni nož z zanko na koncu ploščatega držaja.³⁷⁵ Zdi se, da so slednja grobova poškodovali naknadni pokopi iz poznolatskega obdobja.

Glede na lego grobov in kronološko izpovedne pridatke lahko pokope s tovrstnimi sekirami na Magdalenski gori datiramo v negovsko stopnjo. Drugo središče

es.³⁷¹ The above overview of the decorations indicates no chronological connotations for the different styles.

ONE-SIDED WINGED AXES

Most of the iron axes of this type from Magdalenska gora (fig. 46: 21–26) were found during the excavations by the Duchess of Mecklenburg.³⁷² The descriptions of graves with such axes reveal that the graves lay at rather shallow depths within tumuli. Grave VII/11 at Preloge, for instance, lay 35cm beneath the surface, Grave VII/23 was reportedly also found at a shallow depth; while for Grave VI/39 at Preloge, with an openwork belt clasp among the grave goods, Goldberg wrote that the axe (socketed) and the "hoe" (winged axe) had been found 30cm below the surface on the easternmost edge of the tumulus and about half a metre above the said grave. Grave X/64 was found on the south-eastern edge of Tumulus X at Preloge and only 25cm below the sod. The deceased in the grave was a tall young male with Alpine traits,³⁷³ buried with a one-sided winged axe, a socketed axe, one small and two slender spearheads, a Type X Certosa fibula, a lead armlet and a knife with a flat tang and rivets. A winged axe was also found beside the deceased in Grave IV/58, whom Angel determined as a young adult male with gracile Mediterranean traits (fig. 6).³⁷⁴

The tumulus dug by the Duchess at Laščik revealed a one-sided winged axe in Grave V/19–20, which contained two poorly preserved skeletons. Placed between them was an iron sword, two long spearheads and an axe. Published as forming part of the grave is also a shaft-hole axe from the collection of the National Museum in Ljubljana, which is not mentioned by Goldberg.

Three grave groups with a one-sided winged axe and one individual find are recorded from Pečnik's excavation of Tumulus 2 at Preloge. In Grave 2/69, such an axe was reportedly found together with a spearhead, two knives, an animal tooth and a pair of beautiful Certosa fibulae, the latter now missing. In Graves 2/41 and 2/49, an axe was found alongside Late La Tène elements such as an iron umbo and a battle knife with a flat tang and loop terminal.³⁷⁵ The latter two graves appear to have been disturbed by subsequent, Late La Tène burials.

Considering the position of graves and the chronologically telling grave goods, burials with one-sided winged axes at Magdalenska gora can be dated to the

³⁷¹ Preloge, gr. X/23, X/25, 13/120: Hencken 1978, Fig. 314, 317; Tecco Hvala/Dular/Kocuvan 2004, T. 110: 3.

³⁷² Gr. IV/58, V/8, V/19–20, VI/29, VI/39, VII/11, VIII/23, X/64: Hencken 1978, Fig. 96b, 113, 125g, 203, 213h, 230b, 241c, 350d.

³⁷³ Angel 1968, 96 s, Fig. 14.

³⁷⁴ Ibid., 78, Fig. 2.

³⁷⁵ Tecco Hvala/Dular/Kocuvan 2004, 40 s, 43, 47, T. 38A: 3, 38B: 3, 58B: 4, 126: 26.

³⁷¹ Preloge, Gr. X/23, X/25, 13/120: Hencken 1978, Figs. 314, 317; Tecco Hvala/Dular/Kocuvan 2004, T. 110: 3.

³⁷² Gr. IV/58, V/8, V/19–20, VI/29, VI/39, VII/11, VIII/23, X/64: Hencken 1978, Figs. 96b, 113, 125g, 203, 213h, 230b, 241c, 350d.

³⁷³ Angel 1968, 96 f, Fig. 14.

³⁷⁴ Ibid., 78, Fig. 2.

³⁷⁵ Tecco Hvala/Dular/Kocuvan 2004, 40 f, 43, 47, T. 38A: 3, 38B: 3, 58B: 4, 126: 26.

sekir z enostranskimi plavutmi je bilo v Dolenjskih Toplicah.³⁷⁶ V tamkajšnjih grobovih se pojavljajo večinoma z eno sulico in/ali nožem, v enem primeru pa s tulasto sekiro. Med redkimi drugimi pridatki srečamo pravokotne spono in pasne jezičke, železno kavljasto spono s sredinsko prečko, bronasto predrto spono, certoške fibule vrst VIIb, X in XII, ki prav tako označujejo negovsko stopnjo.³⁷⁷ V Novem mestu so izpričane že v predhodni stopnji, kar nakazuje kombinacije z dvo-grebenasto čelado in certoškima fibulama vrste XIII.³⁷⁸

V Posočju se pojavljajo tudi v kontekstih iz mlajše železne dobe;³⁷⁹ v latenskem kulturnem miljeju so se uporabljale kot orodje, ki ima običajno trapezasto razširjeno rezilo.³⁸⁰ En tak primer je bil najden tudi na Magdalenski gori, dozdevno med Schulzovim izkopavanjem gomile 6 na Voselci pri Hrastju.³⁸¹

UHATE SEKIRE

Narodni muzej v Ljubljani in Naravoslovni muzej na Dunaju hranita osemnajst primerkov železnih uhatih sekir z Magdalenske gore (*sl. 46: 15–18*). V dunajskem muzeju so inventarizirane po grobovih,³⁸² v ljubljanski zbirki pa tipološko brez ohranjenih grobnih celot, toda iz najdiščnih oznak v inventarni knjigi je moč razbrati, da so bili trije primerki odkriti v okviru Schulzovega izkopavanja gomile 6 na Voselci,³⁸³ vsaj štirje pa verjetno med Pečnikovim kopanjem gomile 2 na Prelogah.³⁸⁴ Tri uhate sekire iz ljubljanskega muzeja objavlja še Hencken v grobnih sestavih V/9, V/11 in V/19–20 z Laščika, ki jih Goldberg v opisu teh grobov ne navaja.³⁸⁵ Peabodyjev muzej tako hrani le dve uhate sekiri, ena naj bi pripadala

³⁷⁶ Teržan 1973, 685; ead. 1976, 387; Stary 1982, 41, Abb. 6, Liste 6. K njegovemu seznamu lahko dodamo še nekaj primerkov iz dolenjskih najdišč, kot so: *Novo mesto*: Knez 1986, T. 7: 11, 19: 19, 52: 10; Križ 1997, T. 1: 2; *Rovišče*: Stare V. 1962–1963, T. 3: 5; *Stična*: Gabrovec et al. 2006, T. 164: 63,64; *Vače*: neobjavljeno, NHMW inv. št. 6705, 71283 ter en primerek brez inv. št.

³⁷⁷ *Dolenjske Toplice*, gr. 3/3, 5/23, 10/9, 11/9, 11/11, 11/23, 11/26, 13/4: Teržan 1976, T. 1: 12, 10: 1, 19: 2, 22: 9, 27: 5, 28: 1, 33: 8, 36: 6, 41: 4, 55: 6, 59: 6, 64: 9, 67: 3, 70: 2, 71: 10, 74: 8, 75: 2, 78: 10, 80: 2, 84: 10, 85: 6, 86: 2, 88: 4.

³⁷⁸ *Znančeve njive*, gr. 1/23, 2/9: Knez 1986, T. 6–8, 19: 1–20.

³⁷⁹ *Idrija pri Bači, Bodrež*: Guštin 1991, T. 2: 4,5, 5: 4,5, 10: 12,13, 11: 6, 14: 16, 15: 6, 19: 2, 38: 2,3.

³⁸⁰ Gabrovec 1966c, 257; Teržan 1973, 685.

³⁸¹ Gabrovec 1966c; T. 24: 7; Tecco Hvala/Dular/Kocuvan 2004, T. 165: 2.

³⁸² *Preloge*, gr. 2/1–2, 2/6, 2/45, 2/71, 13/37, 13/40, 13/60: Tecco Hvala/Dular/Kocuvan 2004, T. 16: 19, 18B: 7,8, 40A: 2, 59C: 4, 77B: 10, 78A: 40, 87A: 5.

³⁸³ *Ibid.*, T. 166: 1–3.

³⁸⁴ *Ibid.*, T. 165: 5, 6, 166: 4–6.

³⁸⁵ Hencken 1978, Fig. 115, 118, 125d (NMS inv. št. P 11838, 11839, 11844).

Negova phase. Another centre for this axe type was at Dolenjske Toplice.³⁷⁶ The axes there appear mostly with a spearhead and/or a knife, in one grave with a socketed axe. Other grave goods are rare and consist of rectangular belt clasps and belt attachments, an iron hook clasp with a central bar, a bronze openwork clasp, Certosa fibulae of Types VIIb, X and XII, which also mark the Negova phase.³⁷⁷ At Novo mesto, combinations with a double-crested helmet and two Type XIII Certosa fibulae indicate the previous phase.³⁷⁸

One-sided winged axes appear in the Soča Valley also in Late Iron Age contexts;³⁷⁹ they were used as implements in the La Tène cultural milieu, usually with a wide trapezoid blade.³⁸⁰ One such example was also found at Magdalenska gora, supposedly during Schulz's excavation of Tumulus 6 at Voselca.³⁸¹

SHAFT-HOLE AXES

The National Museum in Ljubljana and the Museum of Natural History in Vienna keep eighteen iron shaft-hole axes from Magdalenska gora (*fig. 46: 15–18*). They are inventoried according to grave groups in the museum in Vienna³⁸² and according to type in the Ljubljana collection. However, for the latter finds it was possible to discern, on the basis of findspots marked in the inventory book, that three examples were found during Schulz's excavation of Tumulus 6 at Voselca³⁸³ and at least four probably during Pečnik's excavation of Tumulus 2 at Preloge.³⁸⁴ Further three shaft-hole axes from the museum in Ljubljana were published by Hencken as the goods of Graves V/9, V/11 and V/19–20 at Laščik, though Goldberg did not mention them in

³⁷⁶ Teržan 1973, 685; ead. 1976, 387; Stary 1982, 41, Abb. 6, Liste 6. Stary's list can be supplemented with examples from the sites in Dolenjska, namely *Novo mesto*: Knez 1986, T. 7: 11, 19: 19, 52: 10; Križ 1997, T. 1: 2; *Rovišče*: Stare V. 1962–1963, T. 3: 5; *Stična*: Gabrovec et al. 2006, T. 164: 63,64; *Vače*: unpublished, NHMW Inv. Nos. 6705, 71283 and one example without an Inv. No.

³⁷⁷ *Dolenjske Toplice*, Gr. 3/3, 5/23, 10/9, 11/9, 11/11, 11/23, 11/26, 13/4: Teržan 1976, T. 1: 12, 10: 1, 19: 2, 22: 9, 27: 5, 28: 1, 33: 8, 36: 6, 41: 4, 55: 6, 59: 6, 64: 9, 67: 3, 70: 2, 71: 10, 74: 8, 75: 2, 78: 10, 80: 2, 84: 10, 85: 6, 86: 2, 88: 4.

³⁷⁸ *Znančeve njive*, Gr. 1/23, 2/9: Knez 1986, T. 6–8, 19: 1–20.

³⁷⁹ *Idrija pri Bači, Bodrež*: Guštin 1991, T. 2: 4,5, 5: 4,5, 10: 12,13, 11: 6, 14: 16, 15: 6, 19: 2, 38: 2,3.

³⁸⁰ Gabrovec 1966c, 257; Teržan 1973, 685.

³⁸¹ Gabrovec 1966c; T. 24: 7; Tecco Hvala/Dular/Kocuvan 2004, T. 165: 2.

³⁸² *Preloge*, Gr. 2/1–2, 2/6, 2/45, 2/71, 13/37, 13/40, 13/60: Tecco Hvala/Dular/Kocuvan 2004, T. 16: 19, 18B: 7,8, 40A: 2, 59C: 4, 77B: 10, 78A: 40, 87A: 5.

³⁸³ *Ibid.*, T. 166: 1–3.

³⁸⁴ *Ibid.*, T. 165: 5, 6, 166: 4–6.

grobu VII/15 s Prelog (*sl. 46: 20*), v katerem Goldberg omenja kopačo (tako je običajno označena plavutasta sekira), zapestnico in jantarne jagode; druga je fragmentirana (*sl. 46: 19*) in naj bi izšla iz iste gomile, vendar se ne ve, kateremu grobu je pripadala.³⁸⁶

Poglejmo si še spremne pridelke v grobnih celotah v dunajskem muzeju, ki izvirajo iz gomil 2 in 13. V sklopu groba 2/1–2 so med drugim inventarizirane ena uhata in dve tulasti sekiri, vendar o tem grobu ni na voljo nobenih podatkov, pridelki pa kažejo, da gre za več oprav, ki spadajo v različne kronološke stopnje. Pečnikova zapisa o grobu 2/6 nista skladna, v enem omenja le eno uhato sekiro, nož, dve zapestnici in pasne okove, v drugem pa govori o dveh sekirah. Grob 2/45, v katerem nastopa uhata sekira s ščitno grbo in udarnim nožem, je označil za latenski. V grobnem sestavu 2/71 jo srečamo v kombinaciji s sulično ostjo, bronasto predrto pasno spono ter dvema poznolatskima fibulama z dolgo samostrelno peresovino, zraven so bile menda najdene še steklene jagode. Slednja dva sestava sta verjetno kontaminirana. Bolj zanesljive so grobne celote iz gomile 13. Opravo 175 cm visokega moža, pokopanega v grobu 13/60, so razen take sekire sestavljali dve dolgi sulični osti, nož s ploščatim nastavkom za ročaj in certoška fibula vrste IX. V grobu 13/37 so pri okostju, ki je merilo 170 cm, našli uhato sekiro skupaj z nožem, železnimi obročki, dvema svinčenima narokvicama in certoško fibulo vrste XI. Pokojnik v grobu 13/40, visok le okoli 160 cm, pa je bil opremljen samo z uhato sekiro in sulično ostjo.³⁸⁷ Tri uhate sekire z Magdalenske gore je neznano kdaj in od koga pridobil Janez Švajncer za svojo zbirko v Vojnem muzeju v Logatcu.³⁸⁸

Pojav uhatih sekir je geografsko omejen na prostor med rekami Soča, Dravo, Savo in Kolpo v zgornjem delu.³⁸⁹ V primerjavi s sočasnimi primerki z enostranskimi plavutmi so na teritoriju dolenjske skupnosti slabše zastopane. Grobne celote so za zdaj poznane z Magdalenske gore ter ena z latensko železno čelado iz Trbinca pri Mirni³⁹⁰ in dve s Kapitelske njive v Novem mestu, kjer sta bili odkriti v okviru žganih grobov na planem grobišču iz mlajše železne dobe.³⁹¹ Po številu uhatih sekir se z Magdalensko goro lahko primerja le Šmihel na Notranjskem,³⁹² ki pa po enoplavutastih primerkih zaostaja za njo.³⁹³ Obe vrsti sekir je moč pripisati inovativnosti jugovzhodnoalpskega prostora v času negovske stopnje, kjer so se ponekod v modificirani

his descriptions of the graves.³⁸⁵ The Peabody Museum keeps only two shaft-hole axes, one supposedly from Grave VII/15 at Preloge (*fig. 46: 20*), from which Goldberg mentions a hoe (name usually used to describe a one-sided winged axe), a bracelet and amber beads; while the other is fragmented (*fig. 46: 19*) and was supposedly found in the same tumulus, though its grave provenance is not known.³⁸⁶

As for the grave groups from Tumuli 2 and 13 kept in the museum in Vienna, the goods alongside the axes are the following. Inventoried within Grave 2/1–2 are one shaft-hole and two socketed axes, whereby no other data is available for this grave and its goods indicate several costumes from different phases. For Grave 2/6, Pečnik's two notes differ in the number of objects, listing one shaft-hole axe, a knife, two bracelets and belt fittings in the first and two axes in the second. Grave 2/45, in which a shaft-hole axe was found with an umbo and a battle knife, was marked as La Tène by Pečnik. In Grave 2/71, a shaft-hole axe was found in combination with a spearhead, bronze openwork belt clasp and two Late La Tène fibulae with a wide crossbow spring, reportedly also with glass beads. Having said that, the latter two groups are probably contaminated. Less questionable are the grave groups from Tumulus 13. The 175cm tall male in Grave 13/60 was buried with a shaft-hole axe, two long spearheads, a knife with a flat tang and a Type IX Certosa fibula. The 170cm long skeleton in Grave 13/37 had a shaft-hole axe, a knife, iron rings, two lead armlets and a Type XI Certosa fibula. The merely 160cm tall deceased in Grave 13/40 only had a shaft-hole axe and a spearhead.³⁸⁷ Further three shaft-hole axes were acquired by Švajncer for his collection at the Logatec War Museum, though the details of the acquisition are not known.³⁸⁸

The appearance of shaft-hole axes is limited to the area between the Soča, Drava, Sava and the Kolpa River in its upper reaches.³⁸⁹ Compared to the contemporary one-sided winged axes, they are less well represented on the territory of the Dolenska community. Grave groups with this axe type are thus far known at Magdalenska gora, one grave group with an iron La Tène helmet is known from Trbinc near Mirna³⁹⁰ and two from Kapitelska njiva in Novo mesto, where the axes were found in cremation graves of the Late Iron Age flat cemetery.³⁹¹ In the number of shaft-hole axes, only Šmihel in Notranjska can compare with Magdalenska

³⁸⁶ *Ibid.*, Fig. 234e, 274i.

³⁸⁷ Tecco Hvala/Dular/Kocuvan 2004, 32 s, 41, 47, 58 s, 62.

³⁸⁸ Švajncer 2012, 9 ss.

³⁸⁹ Teržan/Trampuž 1973, 434, op. 67, sl. 4: karta 3; Stary 1982, Abb. 7, Liste 7.

³⁹⁰ Gabrovec 1990b, 108 s, sl. 7: 2.

³⁹¹ *Gr. 123, 458: Križ* 2005, T. 13: 4, 77: 3.

³⁹² Guštin 1979, T. 56: 3, 75: 1-9, 76: 1-9, 77: 1,2.

³⁹³ *Ibid.*, T. 77: 3,7,8.

³⁸⁵ Hencken 1978, Figs. 115, 118, 125d (NMS Inv. Nos. P 11838, 11839, 11844).

³⁸⁶ *Ibid.*, Figs. 234e, 274i.

³⁸⁷ Tecco Hvala/Dular/Kocuvan 2004, 32, 41, 47, 58, 62.

³⁸⁸ Švajncer 2012, 9 ff.

³⁸⁹ Teržan/Trampuž 1973, 434, n. 67, Fig. 4. 3; Stary 1982, Abb. 7, Liste 7.

³⁹⁰ Gabrovec 1990b, 108 f, Abb. 7: 2.

³⁹¹ *Gr. 123, 458: Križ* 2005, T. 13: 4, 77: 3.

obliki obdržale še v mlajši železni dobi.³⁹⁴ Možno bi sicer bilo, da so ideje za uhato sekiro povzeli po t. i. skitoidnih sekirah vzhodne provenience, kot namiguje Stary;³⁹⁵ navsezadnje je bilo nekaj takih primerkov najdenih na Dolenjskem in sodijo v čas certoške stopnje, ki so jo zaznamovali skitski vplivi, kar se najbolj odraža v t. i. skitskih konjih, brzdah ter puščičnih osteh.

Sekire na splošno ne predstavljajo novosti v obožitvi, ki bi bila povezana z nastopom železne dobe, temveč jih je moč razumeti kot nadaljevanje tradicije iz časa kulture žarnih grobišč. V pozni bronasti dobi so zastopane v večini depojev in predstavljajo največji delež med posameznimi kovinskimi najdbami,³⁹⁶ razen tega jih v času Ha B zasledimo tudi že v grobovih.³⁹⁷ V Ljubljanski kotlini in v dolensko-belokranjski regiji so izpričani številni bronasti primerki plavutastih³⁹⁸ in tulastih sekir.³⁹⁹ Ob tem velja omeniti še bronasto tulasto kladivo z Magdalenske gore, ki je objavljeno med posamičnimi najdbami gomile VIII na Prelogah, kamor zagotovo ne sodi,⁴⁰⁰ spominja pa na tovrstne predmete iz starejšega obdobja kulture žarnih grobišč.⁴⁰¹

Proces zamenjave bronastega orožja z železnim je bil postopen.⁴⁰² V grobovih iz starejšega halštatskega obdobja na Dolenjskem srečamo bronasto in železne sekire z dvostranskimi plavutmi ter tulaste in križne primerke, ki tako ne izražajo neke oblikovne homogenosti. Železne sekire so bile v tem času še maloštevilne in so pripadale le najelitnejšim opravam.

Preobrat v obožitvi dolenske skupnosti je nastopil v začetku mlajšega halštatskega obdobja (Ha D1). Zastopnost železnih tulastih sekir se je takrat

³⁹⁴ Gabrovec 1966c, 189, T. 6: 2,5; id. 1990b, 109; Teržan/Trampuž 1973, 435, sl. 4: karta 3; Teržan 1973, 685; ead. 1976, 393; ead. 1977, 14; Guštin 1977, 68; id. 1991, 59 s. Primerki uhatih sekir iz *Idrije pri Bači*, gr. 9, 16, 17 in *Reke pri Cerknem*, gr. 3, 6, 10 imajo na temenu kladivast nastavek: Guštin 1991, T. 10: 11, 14: 4, 15: 4, 31: 2, 32: 6, 33: 1.

³⁹⁵ Stary 1982, 42 ss.

³⁹⁶ Čerče/Turk 1996, 14, sl. 2–6; Šinkovec 1996, 148, sl. 4.

³⁹⁷ Teržan 1990a, 24. Npr. *Velika Gorica*, gr. 7/1908, 1/1911: Vinski-Gasparini 1973, T. 102: 1; 103: 4, *Škocjan-Brežec*, gr. 158: Ruaro Loseri 1977, T. 16: 3; Teržan 1995a, 360, Abb. 28: 10; *Ljubljana-dvorišče SAZU*, gr. 39: Stare F. 1954b, T. 30: 1; Gabrovec 1973, 343; *Novo mesto-Mestne njive*, gr. 384: Križ et al. 2009, 233, Kat. št. 4.2.5; *Ormož*, gr. 9: Tomanič-Jevremov 1988–1989, T. 18: 4.

³⁹⁸ Šinkovec 1995, T. 12: 69, 13: 73,74,77; ead. 1996, 134 s.

³⁹⁹ Šinkovec 1995, T. 14: 78,79, 15: 82–86, 16: 89,91, 17: 93–96,100,101, 18: 102–104,106–110, 19: 111–115,118, 20: 123,124,126,127, 21: 132; ead. 1996, 135 ss.

⁴⁰⁰ Hencken 1978, 65, Fig. 296.

⁴⁰¹ Mayer 1977, T. 90: 1333–1336, 1338,1339, 134; Kibbert 1984, T. 70: 982–985; Řihovský 1992, T. 81: 1377; Žeravica 1993, T. 41: 596–601; Teržan 1996a, 244 s, op. 7.

⁴⁰² Egg 2004b, 44.

gora,³⁹² though it lags behind in the number of one-sided winged axes.³⁹³ Both axe types may be attributed to the innovativeness of the south-eastern Alpine area in the Negova phase, where they continued to be used in a modified form into the Late Iron Age.³⁹⁴ Having said that, it would also be possible for the shaft-hole idea to have been taken from the so-called Scythoid axes of eastern provenance, as suggested by Stary.³⁹⁵ There were, in fact, several examples of these axes found in Dolenjska from the Certosa phase marked by Scythian influence, which is best reflected in the so-called Scythian horses, bridle-bits and arrowheads.

Axes in general do not represent a novelty in armament at the beginning of Iron Age, but can rather be understood as a continuation of the Urnfield culture tradition. In the Late Bronze Age, axes appeared in most of the hoards and represented the greatest share among individual metal finds,³⁹⁶ while in Ha B they already appeared in graves.³⁹⁷ Numerous bronze examples of winged³⁹⁸ and socketed axes³⁹⁹ were found in the Ljubljana basin as well as in Dolenjska and Bela krajina. Noteworthy is also the find of a bronze socketed hammer from Magdalenska gora, published among individual finds in Tumulus VIII at Preloge, to which it certainly does not belong.⁴⁰⁰ It is reminiscent, however, of such objects from the Early Urnfield culture period.⁴⁰¹

³⁹² Guštin 1979, T. 56: 3, 75: 1–9, 76: 1–9, 77: 1,2.

³⁹³ *Ibid.*, T. 77: 3,7,8.

³⁹⁴ Gabrovec 1966c, 189, T. 6: 2,5; id. 1990b, 109; Teržan/Trampuž 1973, 435, Fig. 4. 3; Teržan 1973, 685; ead. 1976, 393; ead. 1977, 14; Guštin 1977, 68; id. 1991, 59 f. Graves 9, 16, 17 from *Idrija pri Bači* and Graves 3, 6, 10 from *Reka pri Cerknem* contained examples of shaft-hole axes with a hammer-shaped apex: Guštin 1991, T. 10: 11, 14: 4, 15: 4, 31: 2, 32: 6, 33: 1.

³⁹⁵ Stary 1982, 42 ff.

³⁹⁶ Čerče/Turk 1996, 14, Figs. 2–6; Šinkovec 1996, 148, Fig. 4.

³⁹⁷ Teržan 1990a, 24. For example: *Velika Gorica*, Gr. 7/1908, 1/1911: Vinski-Gasparini 1973, T. 102: 1; 103: 4, *Škocjan-Brežec*, Gr. 158: Ruaro Loseri 1977, T. 16: 3; Teržan 1995a, 360, Abb. 28: 10; *Ljubljana-SAZU*, Gr. 39: Stare F. 1954b, T. 30: 1; Gabrovec 1973, 343; *Novo mesto-Mestne njive*, Gr. 384: Križ et al. 2009, 233, Cat. No. 4.2.5; *Ormož*, Gr. 9: Tomanič-Jevremov 1988–1989, T. 18: 4.

³⁹⁸ Šinkovec 1995, T. 12: 69, 13: 73,74,77; ead. 1996, 134 f.

³⁹⁹ Šinkovec 1995, T. 14: 78,79, 15: 82–86, 16: 89,91, 17: 93–96,100,101, 18: 102–104,106–110, 19: 111–115,118, 20: 123,124,126,127, 21: 132; ead. 1996, 135 ff.

⁴⁰⁰ Hencken 1978, 65, Fig. 296.

⁴⁰¹ Mayer 1977, T. 90: 1333–1336, 1338,1339, 134; Kibbert 1984, T. 70: 982–985; Řihovský 1992, T. 81: 1377; Žeravica 1993, T. 41: 596–601; Teržan 1996a, 244 f, n. 7.

močno povečala, izpodrinile so druge tipe in postale standardni kos ne le v opravah veljakov, temveč tudi skromneje opremljenih pešakov, s čimer se nakazujejo obrisi nekakšne teritorialne vojaške formacije.

Spremembe vnovič zaznamo ob koncu halštatskega obdobja, ko so vzniknile nove oblike sekir – uhate in take z enostranskimi plavutmi. Pojav teh oblik in njun odnos je precej zagoneten. Obe vrsti imata središče v jugovzhodnoalpskem svetu – plavutaste v Dolenjskih Toplicah in na Magdalenski gori, uhate pa na Magdalenski gori in v Šmihelu na Notranjskem. Običajno nastopata v skromnejših opravah, večkrat kot edini pridelek v grobu, medtem ko jih med opremo vodilnih predstavnikov dolenske skupnosti ne zasledimo. Izjemo predstavlja le novomeški veljak, pokopan v grobu 1/23 na Znančevih njivah, ki je nosil poleg sekire z enostranskimi plavutmi še eno tulasto ter skitske puščice, dve sulici, nož in dvo-grebenasto čelado, kar po drugi strani govori za to, da so sekire z enostranskimi plavutmi prišle v uporabo nekoliko pred uhatimi.⁴⁰³ Na Magdalenski gori ju srečamo v istih gomilah in v podobnih sestavih. Tudi antropološka analiza okostij iz teh grobov ne daje kakšnih posebnih namigov o njihovih nosilcih. Na obe vrsti sekir naletimo še v kontekstih iz mlajše železne dobe.

Primerjava Magdalenske gore z drugimi dolenskiimi najdišči razkriva njeno izrazito premoč v količini sekir (*sl.* 47), to velja predvsem za mlajše halštatsko

⁴⁰³ Teržan 1977, 11 ss.

Najdišče Site	Vrste sekir / Types of axes						Skupaj Total
	Plavutaste 2 Winged 2	Križne Lugged	Tulaste Socketed	Plavutaste 1 Winged 1	Uhate Shaft-hole		
Magdalenska gora	1	1	119	14	23	158	
Vače	2	2	49	5	1	59	
Dolenjske Toplice			23	23		46	
Stična	3	3	33	2	2	43	
Veliki Vinji vrh (Šmarjeta)		1	33	3	3	40	
Dobrnič			17	3		20	
Vinkov Vrh			17		2	19	
Libna	2		15			17	
Valična vas			12	1	4	17	
Podzemelj			11	2	4	17	
Novo mesto		3	9	4		16	
Brezje			10	1		11	
Rovišče			8	1		9	
Brusnice			5			5	
Velike Malence	1	1	2			4	

The process of replacing bronze weapons with those made of iron was gradual.⁴⁰² Early Hallstatt graves from Dolenjska often revealed bronze winged axes and the same axe form in iron as well as socketed and lugged axes, thus not offering a homogenous picture of armament. Actually, iron axes in this period are not numerous and were buried with only the most prominent individuals.

The change in the armament of the Dolenjska community is noticeable at the beginning of the Late Hallstatt period (Ha D1). The quantity of iron socketed axes increased substantially at that time, they ousted other types and became the standard piece of armament not only for the dignitaries, but also the less well equipped infantrymen, which offers an outline of a sort of local military formation.

Changes can again be observed at the end of the Hallstatt period, when new axe forms appear – shaft-hole and one-sided winged axes. Their appearance and interrelationship, however, has not yet been explained. Production centres of both types can be sought in the south-eastern Alpine area – winged axes at Dolenjske Toplice and Magdalenska gora, and shaft-hole axes at Magdalenska gora and Šmihel in the Notranjska region. They were usually found in poorer graves, in several as the only good, while they do not figure among the grave goods of the dignitaries. The exception to the latter is the dignitary in Grave 1/23 at Znančeve njive, Novo mesto, who was buried with a one-sided winged axe, a socketed axe, Scythian arrowheads, two spears, a knife and a double-crested helmet. This grave group also indicates that one-sided winged axes came into use somewhat earlier than the shaft-hole axes.⁴⁰³ At Magdalenska gora, they appeared in the same tumuli and as parts of similar grave groups. The anthropological analysis of the skeletons from these graves also offers no particular clues as to their bearers. Both axe forms were also found in Late Iron Age contexts.

The comparison of Magdalenska gora with other sites in Dolenjska reveals the site's superiority in the quantity of axes (*fig.* 47), particularly in the Late Hallstatt period, while in earlier phases, namely Podzemelj and Stična, its position was less prominent. The earliest axe at Magdalenska gora was the iron winged axe found in cremation cist Grave 12/1 at Laščik, dated to the Podzemelj 2 phase; the grave might even represent the earliest burial with weapons at the site. An axe was

⁴⁰² Egg 2004b, 44.

⁴⁰³ Teržan 1977, 11 ff.

Sl. 47: Številčno razmerje med posameznimi tipi železnih sekir v dolenski skupnosti. Plavutaste 1 = sekire z enostranskimi plavutmi; plavutaste 2 = sekire z dvostranskimi plavutmi.

Fig. 47: Quantitative ratio of individual iron axe types in the Dolenjska community. Winged 1 = one-sided winged axes; winged 2 = double-sided winged axes.

obdobje, medtem ko v zgodnejših stopnjah, tj. v stopnjah Podzemelj in Stična, ni imela tako vidne vloge. Za najstarejši primerek na tem najdišču bi lahko opredelili železno sekuro z dvostranskimi plavutmi iz žganega groba s kamnito skrinjo 12/1 na Laščiku, ki ga datiramo v stopnjo Podzemelj 2. Morebiti predstavlja sploh prvi pokop z orožjem na tem najdišču. Na Magdalenski gori je sekira zabeležena v žganem grobu le še v enem primeru – gre za grob VI/22 s Prelog, ki je vseboval železno tulasto sekuro, okrašeno z bronastimi rombičnimi aplikami; prvi predmeti, okrašeni v tej tehniki, se v jugovzhodnih Alpah pojavijo že v stopnji Podzemelj 2 oz. Stična 1. V stopnjo Stična bi lahko uvrstili tudi skeletni grob IV/3 s Prelog, v katerem nastopa železna tulasta sekira v kombinaciji s sestavljeno čelado. Ta tip sekire je pogost v bojnih opravah iz stopenj kačastih in certoških fibul. V najmlajših grobovih iz magdalenskogorskih gomil pa se pojavljata sekira z enostranskimi plavutmi ali uhata sekira. Glede na veliko količino sekir na tem najdišču bi lahko domnevali, da so se bojevniki oskrbovali z orožjem verjetno kar v domačih delavnicah, saj jim je bila surovina dostopna v neposredni okolici.⁴⁰⁴

4.1.2 SULICE, KOPJA IN PUŠČICE

OSTI SULIC IN KOPIJ

Največji delež med napadalnim orožjem pripada suličnim ostem (*sl. 45: A*), ki jih lahko na grobo razdelimo v tri skupine. Prvo skupino predstavljajo primerki, ki imajo kratek tulec za nasaditev in dolg list s poudarjenim sredinskim rebrom (*sl. 48*). Drugo skupino zastopajo dolgi vitki primerki, pri katerih je tul po dolžini enak ali daljši od lista in ima prav tako poudarjeno sredinsko rebro (*sl. 49*). Tretja skupina zajema kratke osti povečini z deltoidno oblikovanim listom rombičnega preseka in neizraženim sredinskim rebrom, ki tekoče prehaja v list (*sl. 50*). Slabo polovico suličnih osti iz magdalensko-gorskih grobov lahko uvrstimo v prvo skupino, petino v drugo skupino in tretjino v tretjo skupino (*sl. 45: A*). Na primerkih iz prve in druge skupine se pojavlja stilno podoben okras kot na sekirah, pri nekaterih se tulec zaključuje z vodoravno prirobnico (*sl. 48: 7*). Manjše osti, ki predstavljajo tretjo skupino, pa niso nikoli ornamentirane (*sl. 50*), metalografska analiza enega izmed vzorčnih primerkov (iz groba IV/25 na Prelogah) je pokazala, da je bil izdelan iz čistega železa in vroče kovan.⁴⁰⁵

Nekje v okolici Magdalenske gore je bila menda najdena tudi bronasta sulična ost, ki jo je muzej v Ljubljani pridobil z odkupom leta 1945.⁴⁰⁶ V Ljubljanski kotlini so zastopani številni bronasti primerki med vodnimi in močvirskimi najdbami iz obdobja kulture žarnih

⁴⁰⁴ Tecco Hvala/Dular/Kocuvan 2004, sl. 3.

⁴⁰⁵ Hencken 1978, Fig. 63n; Geselowitz 1985, 131–135.

⁴⁰⁶ Tecco Hvala/Dular/Kocuvan 2004, T. 164: 8.

found in only one other cremation grave, namely Grave VI/22 at Preloge, which contained an iron socketed axe decorated with bronze rhomboid appliqué; the first objects decorated in this manner appear in the south-eastern Alps already in the Podzemelj 2 or Stična 1 phase. The Stična phase could also be the time frame for inhumation Grave IV/3 at Preloge, in which an iron socketed axe was found together with a composite helmet. Socketed axes often appeared in the warrior outfit of the Serpentine and Certosa Fibulae phases. The latest graves in the tumuli of Magdalenska gora, on the other hand, revealed one-sided winged and shaft-holes axes. Considering the great number of axes at the site and the availability of the raw material in the immediate vicinity,⁴⁰⁴ one might suppose that the warriors were equipped by home-made weapons.

4.1.2 SPEARS, JAVELINS AND ARROWS

SPEAR- AND JAVELINHEADS

The most numerous represented arms are spears (*fig. 45: A*), which can roughly be divided into three groups. The first is constituted by spearheads with a short socket and a long blade with a pronounced midrib (*fig. 48*). The second group is constituted by long and slender spearheads with the socket longer or equally long as the blade and a pronounced midrib (*fig. 49*). Forming the third group are short spearheads with mostly a deltoid blade of rhombic section and an unpronounced midrib that runs smoothly into the blade (*fig. 50*). Almost half of the spearheads from the graves of Magdalenska gora can be attributed to the first group, a fifth into the second group and a third into the third group (*fig. 45: A*). Spearheads of the first and second groups bear stylistically similar decoration as axes, the socket in some examples terminating in a horizontal flange (*fig. 48: 7*). The spearheads of the third group are never decorated (*fig. 50*), while the metallographic analysis of one of such spearheads (from Grave IV/25 at Preloge) showed it to be made of pure iron that was hammered when still hot.⁴⁰⁵

Apart from the iron examples, a bronze spearhead was also found somewhere around Magdalenska gora, which the museum in Ljubljana acquired in 1945.⁴⁰⁶ Numerous bronze spearheads from the Urnfield culture period were found in the waterways and moor of the Ljubljana basin,⁴⁰⁷ while in Dolenjska of this pe-

⁴⁰⁴ Tecco Hvala/Dular/Kocuvan 2004, Abb. 3.

⁴⁰⁵ Hencken 1978, Fig. 63n; Geselowitz 1985, 131–135.

⁴⁰⁶ Tecco Hvala/Dular/Kocuvan 2004, T. 164: 8.

⁴⁰⁷ Šinkovec 1995, T. 22: 136,137, 23: 139,143,144, 24: 147,150,151,153-155, 25: 157,158,161, 26: 168,169,172 etc., Figs. 14, 19, 25, 26; *ead.* 1996, 139 ff.

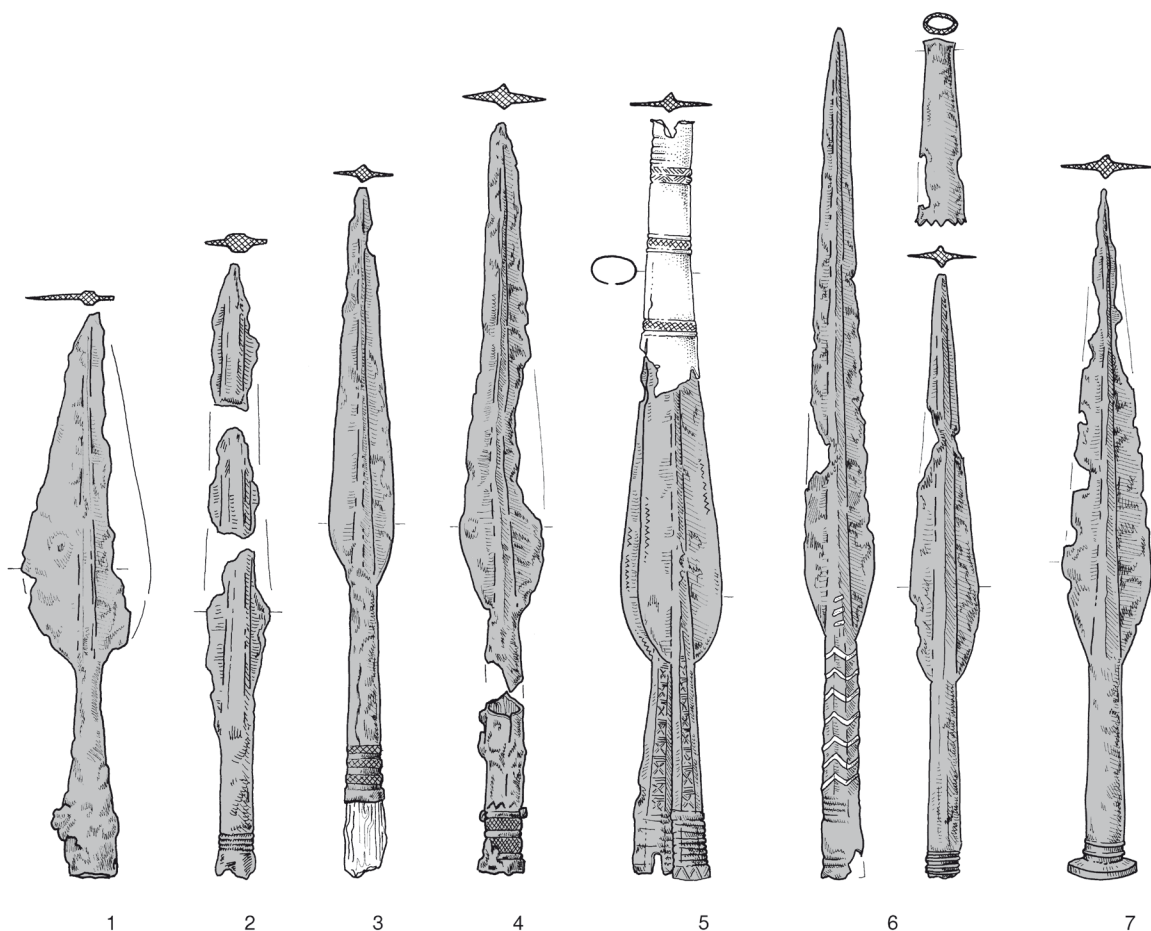

Sl. 48: Sulične osti z daljšim listom in krajšim tulom z Magdalenske gore. M. = 1:4.

Fig. 48: Spearheads with a long blade and a short socket from Magdalenska gora. Scale = 1:4.

1 – Preloge, gr. 13/10; 2 – Preloge, gr. 2/57; 3 – Preloge, gr. 2/58; 4 – Preloge, gr. 2/60; 5 – Preloge, gr. 2/1–2; 6 – Preloge, gr. IV/21; 7 – Preloge, gr. IV/52.

grobišč,⁴⁰⁷ v tem času jih na Dolenjskem zasledimo tudi v depojih⁴⁰⁸ in v grobovih.⁴⁰⁹ Bronaste sulične osti se sporadično pojavljajo še v halštatskih kontekstih,⁴¹⁰

⁴⁰⁷ Šinkovec 1995, T. 22: 136,137, 23: 139,143,144, 24: 147,150,151,153–155, 25: 157,158,161, 26: 168,169,172 itd., sl. 14, 19, 25, 26; ead. 1996, 139 ss.

⁴⁰⁸ Črmošnjice, Jurka vas: Čerče/Šinkovec 1995, sl. 37: 6,7, T. 89: 5,6, 136: 6; Čerče/Turk 1996, 14, sl. 3, 9.

⁴⁰⁹ Teržan 1990, 91; npr. Dobova, gr. 69: Stare F. 1975, T. 14: 11; Novo mesto-Mestne njive, gr. 186, 384: Knez 1984, T. 5: 1,2; Križ 1995, Kat. št. 87, 96.

⁴¹⁰ Kromer 1959a, T. 18: 3; Barth 1969, T. 4: 1; Teržan 1990a, 91, op. 343, Tomedi 2002, T. 42: 6; Dular J. 2003, T. 9: 3, 57: 9. Skupaj z železnimi predmeti se bronasta sulična ost omenja tudi v gomili 7/1901 v Gradenjski hosti pod Velikim Vinjim vrhom (Šmarjeta): Dular A. 1991, 37. Na Vačah je bila najdena bronasta sulična ost, sprijeta z železno sekiro z dvostranskimi plavutmi (neobjavljeno, NHMW inv. št. 6487).

riod they appeared as parts of hoards⁴⁰⁸ and graves.⁴⁰⁹ Bronze spearheads are sporadically recorded in Hallstatt contexts,⁴¹⁰ which speaks of their gradual replacement with iron examples.

The first iron spearheads were documented at Magdalenska gora in two cremation graves dated to the Podzemelj 2 phase. One of them is cremation Grave 12/1

⁴⁰⁸ Črmošnjice, Jurka vas: Čerče/Šinkovec 1995, Figs. 37: 6,7, T. 89: 5,6, 136: 6; Čerče/Turk 1996, 14, Figs. 3, 9.

⁴⁰⁹ Teržan 1990, 91; for example Dobova, Gr. 69: Stare F. 1975, T. 14: 11; Novo mesto-Mestne njive, Gr. 186, 384: Knez 1984, T. 5: 1,2; Križ 1995, Cat. Nos. 87, 96.

⁴¹⁰ Kromer 1959a, T. 18: 3; Barth 1969, T. 4: 1; Teržan 1990a, 91, n. 343, Tomedi 2002, T. 42: 6; Dular J. 2003, T. 9: 3, 57: 9. A bronze spearhead together with iron objects is mentioned among the finds from Tumulus 7/1901 in Gradenjska hosta near Veliki Vinji vrh (Šmarjeta): Dular A. 1991, 37. One bronze spearhead agglutinates with an iron winged axe was also found at Vače (unpublished, NHMW Inv. No. 6487).

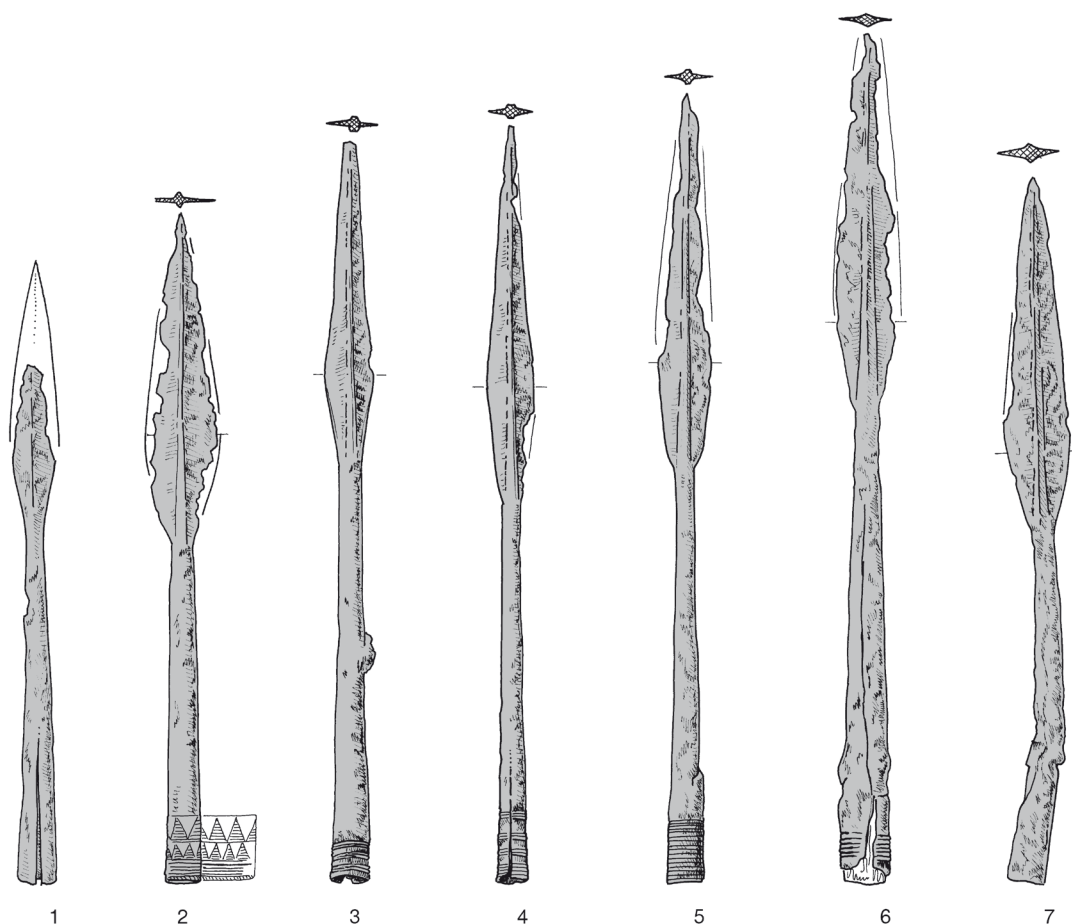

Sl. 49: Vitke sulične osti s krajšim listom in daljšim tulom z Magdalenske gore. M. = 1:4.

Fig. 48: Slender spearheads with a short blade and a long socket from Magdalenska gora. Scale = 1:4.

1 – Preloge, gr. IV/52; 2 – Preloge, gr. X/45; 3 – Laščik, gr. V/11; 4 – Preloge, gr. X/64; 5 – Preloge, gr. X/21a; 6 – Preloge, gr. 13/84; 7 – Preloge, gr. 13/60.

kar govori o njihovem postopnem nadomeščanju z železnimi primerki.

Na Magdalenski gori so prve železne sulične osti izpričane v dveh žganih grobovih, ki ju lahko datiramo v stopnjo Podzemelj 2. Gre za grob 12/1 z Laščika, ki je po Pečnikovih navedbah vseboval eno ali dve suliči. Ta grobna celota je le delno rekonstruirana, morda bi ji lahko pripisali sulično ost, na kateri so vidne sledi ognja, sprimki sežganih kostnih ostankov in koščki staljene bronaste pločevine, inventarizirana pa je v muzeju v Ljubljani med najdbami brez ohranjenih grobnih celot (sl. 54).⁴¹¹ Robustno sulično ost s kratkim tulom bi lahko prepoznali tudi v železnih fragmentih iz žarnega groba 13/52 s Prelog. V žari je bil še nož, zraven nje pa podoben ciborij kot v grobu 12/1 z Laščika, kar bi govorilo za njuno sočasnost.⁴¹² V gomili 13 na Prelogah je bil

at Laščik, which contained one or two spears according to Pečnik. This grave group is only partly reconstructed and might have included a spearhead with visible traces of fire, agglutinated cremated bones and pieces of melted sheet bronze, inventoried at the museum in Ljubljana among the finds without preserved grave groups (fig. 54).⁴¹¹ The iron fragments from urn Grave 13/52 at Preloge might also be identified as a robust spearhead. The urn further contained a knife, while beside the urn stood a similar footed bowl to the one from Grave 12/1 at Laščik, which would indicate their contemporaneity.⁴¹²

⁴¹¹ Tecco Hvala/Dular/Kocuvan 2004, 24, T. 6B, 163: 5.

⁴¹² *Ibid.*, 61, T. 81B: 1. Inventoried in the context of Grave 13/52 is also a goblet-like red vessel with black painted bands, which is not mentioned in Brattina's description of the grave contents. Dating to the same phase is probably also Grave 2/24 from Voselca, which contained a footed bowl and two robust spearheads, similarly to the above-mentioned graves.

⁴¹¹ Tecco Hvala/Dular/Kocuvan 2004, 24, T. 6B, 163: 5.

⁴¹² *Ibid.*, 61, T. 81B: 1. Kelihaste rdeče posode s črnimi

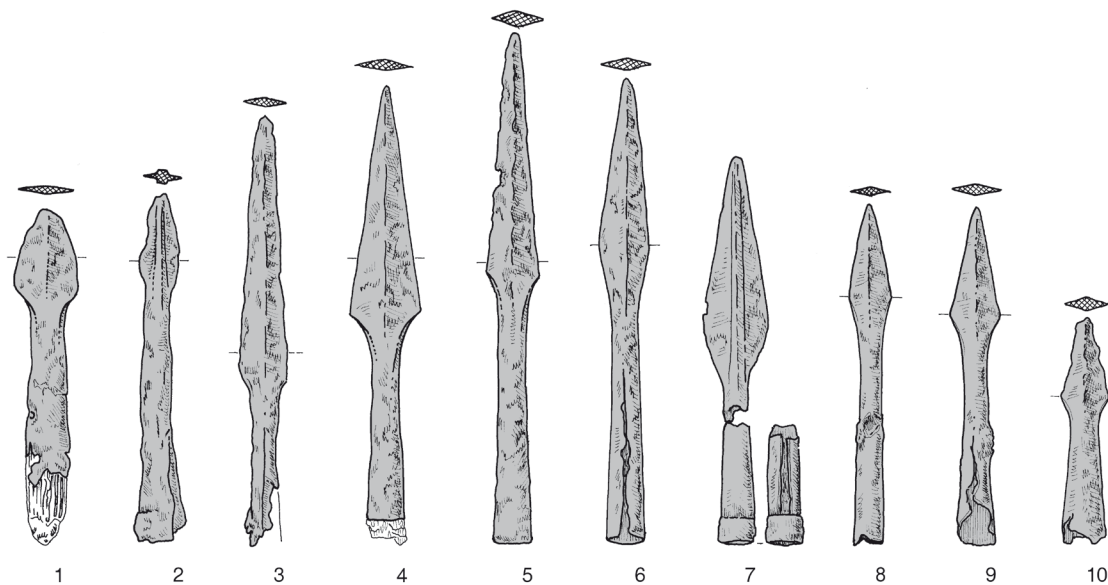

Sl. 50: Osti kopij z listom deltoide oblike in rombičnim presekom z Magdalenske gore. M. = 1:4.

Fig. 50: Javelinheads with a deltoide blade of rhombic cross-section from Magdalenska gora. Scale = 1:4.

- 1 – najdba brez znane grobne celote v NMS / find without preserved context kept in the NMS; 2 – Preloge, gr. 2/47; 3 – Preloge, gr. 2/82; 4 – Preloge, gr. 13/119; 5 – Preloge, gr. 2/1–2; 6 – Laščik, gr. V/19–20; 7 – Preloge, gr. IV/51; 8 – Preloge, gr. X/65; 9 – Preloge, gr. VI/17; 10 – Preloge, gr. VII/23.

odkrit še en žgani pokop s tovrstnim orožjem; gre za grob 13/10 z leseno podlogo, ki je vseboval dve sulični osti, ostanke bodala, velik brusni kamen, rombično pasno spono in apulska kraterja.⁴¹³ Po obliki izstopa sulična ost z izrazito širokim listom (sl. 48: 1), ki ima najboljše primerjave v picenskem prostoru, npr. v Novilari v grobovih iz druge polovice 7. st. pr. n. št.⁴¹⁴ Na Dolenjskem so bile v uporabi sulične osti z daljšim in ožjim listom ter krajšim tulom skozi vso starejšo železno dobo, vendar so za mlajše halštatsko obdobje značilni bolj gracilni primerki.⁴¹⁵ V opravah, kjer nastopajo v paru, je ena običajno daljša, druga pa krajša.⁴¹⁶

barvanimi pasovi, ki je inventarizirana v sklopu groba 13/52, Brattina ne omenja. V ta čas morebiti spada še grob 2/24 z Voselce z dvema robustnima suličnima ostema in podobnim ciborijem, kot sta bila najdena v zgoraj omenjenih grobovih.

⁴¹³ Ibid., 55, T. 68: 5,6.

⁴¹⁴ Beinhauer 1985, 552, Typentafel C: 47,60, T. 88: 988, 91: 1017, 100: 1102, 152: 1711, 187: 2178; Bergonzi 1992, 63, Fig. 2: C,D. V žganem grobu iz gomile 1/1896 v Gradenjski hosti pod Velikim Vinjim vrhom se prav tako omenja velika sulica v kombinaciji z apulskim kraterjem in s t. i. protocertoško fibulo (Dular A. 1991, 35, T. 16), tovrstne fibule pa samo še dodatno potrjujejo povezave z Apeninskim polotokom v drugi polovici 7. st. pr. n. št. (Guštin 1973, 473 s; Guštin/Knific 1973, karta 1: A; Gabrovec 1987, 158 s, sl. 9: 20; id. 1992b, 251, Fig. 2: 17; Blečić 2007, 116, Fig. 8).

⁴¹⁵ Preloge, gr. 2/13, 2/46, 2/57, 2/58, 2/60, 13/5, 13/55, 13/60, 13/85.

⁴¹⁶ Preloge, gr. 2/57, 2/58, 13/85.

Tumulus 13 at Preloge revealed another cremation burial with such a weapon, namely Grave 13/10 with wooden bedding, which contained two spearheads, remains of a dagger, a large whetstone, a rhombic belt clasp and two Apulian *krater*.⁴¹³ One of the spearheads shows a very particular form with a markedly wide blade (fig. 48: 1), the best parallels for which can be found in Picenum, for example at Novilara, in graves from the second half of the seventh century BC.⁴¹⁴

In the Dolenjska region, spearheads with a long blade and a short socket were in use throughout the Early Iron Age, whereby the spearheads of the Late Hallstatt period were generally slenderer.⁴¹⁵ When appearing in pairs, one is usually longer than the other.⁴¹⁶

Slender spearheads of the second group, with the blade shorter than the socket (fig. 49), appear in grave

⁴¹³ Ibid., 55, T. 68: 5,6.

⁴¹⁴ Beinhauer 1985, 552, Typentafel C: 47,60, T. 88: 988, 91: 1017, 100: 1102, 152: 1711, 187: 2178; Bergonzi 1992, 63, Fig. 2: C,D. One big spearhead in combination with an Apulian *krater* and a fibula of so-called proto-Certosa type is also mentioned as the contents of a cremation grave in Tumulus 1/1896 in Gradenjska hosta near Veliki Vinji vrh (Dular A. 1991, 35, T. 16). This fibula type offers additional proof of the connection with the Apennine Peninsula in the second half of the seventh century BC (Guštin 1973, 473 f; Guštin/Knific 1973, Karte 1: A; Gabrovec 1987, 158 f, Fig. 9: 20; id. 1992b, 251, Fig. 2: 17; Blečić 2007, 116, Fig. 8).

⁴¹⁵ Preloge, Gr. 2/13, 2/46, 2/57, 2/58, 2/60, 13/5, 13/55, 13/60, 13/85.

⁴¹⁶ Preloge, Gr. 2/57, 2/58, 13/85.

Vitke sulične osti druge skupine, ki imajo krajši list in daljši tul (*sl.* 49), se pojavljajo v sestavih, ki jih po spremljajočih pridatkih – sekiri z enostranskimi plavutmi ali uhati sekiri, železnih certoških fibulah, železni predrti pasni sponi – lahko datiramo v najmlajšo stopnjo halštatskega obdobja.⁴¹⁷

Osti z listom deltoide sheme in rombičnega preseka (*sl.* 50), ki sem jih uvrstila v tretjo skupino, so precej krajše od onih iz prve in druge skupine, zato bi lahko domnevali, da so imele nemara drugačno funkcijo. Snodgrass je v študiji o grški oborožitvi in bojevanju predpostavljala, da so se kratke osti uporabljale kot kopja, torej kot projektilno orožje za napad z razdalje, medtem ko so se velike sulice uporabljale v boju mož na moža.⁴¹⁸ Na Magdalenski gori so se kratke deltoide osti pojavile v certoški stopnji, o čemer priča grobni sestav 13/119 s Prelog, ki je med drugim vseboval dvogrebenasto čelado. Sicer jih v grobovih vojaške elite ne srečamo, prav tako ne v kombinaciji z drugim projektilnim orožjem, kot so puščice. V sestavih s tulasto sekiro nastopajo v paru,⁴¹⁹ medtem ko v kombinacijah s sekiro z enostranskimi plavutmi ali uhato sekiro največkrat zasledimo le po eno tako kopje,⁴²⁰ kar je morda vpliv latenskega kulturnega kroga.⁴²¹ V grobovih iz Dolenjskih Toplic se take osti pojavljajo bodisi kot edini kos orožja ali pa po ena v kombinaciji s sekiro z enostranskimi plavutmi ali s tulasto sekiro.⁴²² Tudi tam jih v bogatejših opravah ni opaziti. Časovni okvir njihove uporabe na tem najdišču najbolj zgovorno nakazujejo železna fibula in certoške fibule vrst VIIa, Xn, XII, XIII ter predrte pasne sponi. Številni primerki so znani še iz Valične vasi, ki razgrinja gradivo iz poznahalštatskega in latenskega obdobja.⁴²³ Na Trbincu pri Mirni srečamo tako ost kopja v kombinaciji z uhato sekiro in latensko železno čelado.⁴²⁴ Srečamo pa jih tudi na latenskem grobišču v Novem mestu⁴²⁵ in

⁴¹⁷ *Preloge, gr.* 2/69, 13/60, 13/63, 13/132; *Voselca, gr.* 2/23; Tecco Hvala/Dular/Kocuvan 2004, T. 58B: 1, 87A: 2, 88B: 4; 113B: 12, 140A: 3.

⁴¹⁸ Snodgrass 1967, 38 s, 46, 57, 80. Dvoboj s sulicami je upodobljen na raznih predmetih z Apeninskega polotoka: Stary 1981, T. 52, 53, 55: 2.

⁴¹⁹ *Preloge, gr.* 2/47, 2/50, 2/51, 13/119, 13/44 idr.

⁴²⁰ *Preloge, gr.* 2/41, 2/49, 2/71, 13/40 idr.

⁴²¹ Teržan 1976, 388, 393.

⁴²² *Dolenjske Toplice, gr.* 1/11, 2/22, 2/31, 2/35, 3/3, 3/4, 3/8, 5/1, 5/2, 5/23, 5/36, 5/45, 7/2, 7/14, 9/3, 10/5, 10/9, 10/10, 11/6, 11/10, 11/28, 13/1, 13/2, 13/4, 13/5, 13/6, 16/9, 13/12, 16/17; Teržan 1976, T. 3: 12, 10: 2, 14: 16, 16: 6,7, 19: 1,8, 20: 2, 22: 10, 23: 1, 33: 10, 36: 8, 41: 6, 47: 11, 51: 11, 55: 2, 57: 1, 59: 7, 60: 6,7, 62: 6, 65: 1, 65: 1, 74: 1, 75: 1, 77: 2, 78: 2, 79: 1, 80: 1, 88: 2,3, 89: 1.

⁴²³ Teržan 1973, T. 16: 4,5,11, 17: 4,5,8-10, 18: 1-4,9-12, 19: 5,8,9.

⁴²⁴ Gabrovec 1990b, 108 s, sl. 7: 1.

⁴²⁵ Križ 2005, T. 12: 3, 15: 3, 36: 3, 47: 3,4, 53: 2, 69: 5, 98: 4.

groups that may be dated, based on the combinations with iron Certosa fibulae, iron openwork belt clasp, one-sided winged axe or shaft-hole axe, into the latest phase of the Hallstatt period.⁴¹⁷

Spearheads with a deltoide blade of rhombic section (*fig.* 50), of the third group, are considerably shorter than those of the first two groups, which might suggest a different function. Snodgrass, in his study of Greek armament and warfare, postulated that short spearheads were used as javelins and thus as throwing weapons for long-range warfare, while the large spearheads were used in close combat.⁴¹⁸

Short deltoide javelinheads first appeared at Magdalenska gora in the Certosa phase, as evidenced by Grave 13/119 at Preloge, the goods of which included a double-crested helmet. In general, they do not appear in graves of the military elite, neither do they appear in combination with arrowheads, which are also throwing weapons. When forming part of grave groups with a socketed axe, they appear in pairs.⁴¹⁹ Single such javelinheads were usually documented together with either a one-sided winged or a shaft-hole axe.⁴²⁰ The outfit with only one spear or javelin might represent the influence of the La Tène cultural circle.⁴²¹ At Dolenjske Toplice, such javelinheads appear either as the only piece of armament in the grave or, most often, in combination with a one-sided winged or a socketed axe.⁴²² There were not documented in the richer graves. The time frame of their use at this site is best indicated by combinations with an iron fibula, Types VIIa, Xn, XII and XIII Certosa fibulae and openwork belt clasps. Numerous examples of short deltoide javelinheads came to light at Valična vas, where material from the final phase of the Early Iron Age and La Tène periods was found.⁴²³ At Trbinc near Mirna, a javelinhead was found in combination with a shaft-hole axe and a La Tène iron helmet.⁴²⁴ They are also attested to at the La Tène cemetery at Novo mesto,⁴²⁵ and in the area

⁴¹⁷ *Preloge, Gr.* 2/69, 13/60, 13/63, 13/132; *Voselca, Gr.* 2/23; Tecco Hvala/Dular/Kocuvan 2004, T. 58B: 1, 87A: 2, 88B: 4; 113B: 12, 140A: 3.

⁴¹⁸ Snodgrass 1967, 38 f, 46, 57, 80. The duel with spears is depicted on various objects from the Apenine Peninsula: Stary 1981, T. 52, 53, 55: 2.

⁴¹⁹ *Preloge, Gr.* 2/47, 2/50, 2/51, 13/119, 13/44 etc.

⁴²⁰ *Preloge, Gr.* 2/41, 2/49, 2/71, 13/40 etc.

⁴²¹ Teržan 1976, 388, 393.

⁴²² *Dolenjske Toplice, Gr.* 1/11, 2/22, 2/31, 2/35, 3/3, 3/4, 3/8, 5/1, 5/2, 5/23, 5/36, 5/45, 7/2, 7/14, 9/3, 10/5, 10/9, 10/10, 11/6, 11/10, 11/28, 13/1, 13/2, 13/4, 13/5, 13/6, 16/9, 13/12, 16/17; Teržan 1976, T. 3: 12, 10: 2, 14: 16, 16: 6,7, 19: 1,8, 20: 2, 22: 10, 23: 1, 33: 10, 36: 8, 41: 6, 47: 11, 51: 11, 55: 2, 57: 1, 59: 7, 60: 6,7, 62: 6, 65: 1, 65: 1, 74: 1, 75: 1, 77: 2, 78: 2, 79: 1, 80: 1, 88: 2,3, 89: 1.

⁴²³ Teržan 1973, T. 16: 4,5,11, 17: 4,5,8-10, 18: 1-4,9-12, 19: 5,8,9.

⁴²⁴ Gabrovec 1990b, 108 f, Abb. 7: 1.

⁴²⁵ Križ 2005, T. 12: 3, 15: 3, 36: 3, 47: 3,4, 53: 2, 69: 5, 98: 4.

na območju mlajšeželeznodobne idrijske skupine⁴²⁶ ter v severni Italiji v grobovih z zgodnjelatenskimi meči.⁴²⁷

PUŠČIČNE OSTI

Poleg kopij se med projektilno orožje za napad z razdalje uvrščajo še puščične osti. Na Magdalenski gori je znanih pet grobnih celot, ki vsebujejo bronaste in železne puščične osti različnih oblik – ploščate dvokrilne s trni in pa trirobo, ki so v sredini votle in predpostavljajo drugačen način nasaditve (sl. 51).⁴²⁸

Največ jih je imel konjenik iz groba 2/13 s Prelog, ki je nosil dvogrebenasto čelado (sl. 51: 1, 2 in sl. 54). Po Pečnikovih besedah je bil pokopan v krsti iz hlovdov skupaj s konjem; konj je bil obrzdan s skitskimi žvalami in ozaljšan z okrasnimi jermenskimi gumbi in razdelivci. Skromnejšo zbirko puščičnih osti je imel pokojnik v grobu 2/38 iz iste gomile (sl. 51: 3–5), ki je prav tako posedoval dvogrebenasto čelado, tulasto sekiro, pravokotno pasno spono ter še železno britev s koščenim držajem, dve votli narokvici, bronast raženj idr.⁴²⁹ Ti pridatki odražajo čas certoške stopnje; v ta čas bi lahko opredelili tudi grob 13/5 s Prelog, ki je vseboval več bronastih trirobih primerkov in eno dvokrilno ter nekaj železnih puščičnih osti (sl. 51: 6–8), razen tega še sulično ost in pravokotno pasno spono. Manj zanesljiv je grobni sestav IV/43 s Prelog, ki sem ga že omenila v zvezi s križno sekiro; puščični osti, objavljeni v tem sklopu (sl. 51: 9, 10), pa hrani muzej v Ljubljani. Veliko železno puščično ost navaja Goldberg v opisu groba I/3 s Prelog, ki je bil odkrit na robu gomile in naj bi bil žgan. Vseboval je menda še dve zdrobljeni črni posodi, "lovski nož" oz. bodalo, zapestnici in dve fibuli; najdbe so pogrešane.⁴³⁰

Bronaste ploščate dvokrilne puščične osti so na Dolenjskem izpričane že v žarnogrobiščnem kontekstu – v grobišču na Mestnih njivah v Novem mestu.⁴³¹ V starejšem halštatskem obdobju jih zasledimo v grobu s skledasto čelado z Libne⁴³² in v grobu z oklepom iz Stične⁴³³ ter v Dobrniču.⁴³⁴ Železne izvedbe dvokrilnih puščičnih osti so poznane v mlajši halštatski kulturi severno od Alp in v zahodni Panoniji,⁴³⁵ medtem ko

⁴²⁶ Guštin 1991, T. 4: 3, 18: 2, 25: 8, 26: 1, 27: 11, 12, 30: 2, 3.

⁴²⁷ Glej npr. De Marinis 1977, Pl. 2: 9, 3: 4.

⁴²⁸ *Preloge, gr. I/3, IV/43, 2/13, 2/38, 13/5*: Hencken 1978, Fig. 85g,j, 364m; Tecco Hvala/Dular/Kocuvan 2004, T. 26: 26–30, 36: 19–21; 67A: 6–13.

⁴²⁹ Tecco Hvala/Dular/Kocuvan 2004, 35, 39.

⁴³⁰ Hencken 1978, 12 s.

⁴³¹ Knez 1984, T. 3: 8; Križ et al. 2009, 235, Kat. št. 4.2.30, 35a–c.

⁴³² Guštin 1976, T. 57: 2; Guštin/Preložnik 2005, 133 s, sl. 21: 16, op. 23.

⁴³³ Gabrovec et al. 2006, T. 13: 40–49, 211.

⁴³⁴ Parzinger 1988–1989, T. 41: 1–13.

⁴³⁵ Jerem 1968, 184, Fig. 24: 31/5, op. 72; Egg 1985a,

of the Late Iron Age Idrija group,⁴²⁶ as well in northern Italy, the latter in graves with Early La Tène swords.⁴²⁷

ARROWHEADS

Another type of throwing weapons is bows and arrows. At Magdalenska gora, five grave groups were documented that include either bronze or iron arrowheads of various forms – flat tanged bilobate with barbs and socketed trilobate (fig. 51).⁴²⁸

The greatest number of arrowheads was buried with the horseman in Grave 2/13 at Preloge, who wore a double-crested helmet (figs. 51: 1, 2 and 54). According to Pečnik, he was buried in a coffin of timbers together with a horse. The latter was bitted with a Scythian bridle-bit and adorned with strap buttons and phalerae. A smaller collection of arrowheads was found with the deceased in Grave 2/38 from the same tumulus (fig. 51: 3–5), who also wore a double-crested helmet. Other goods in the grave include a socketed axe, a rectangular belt clasp, an iron razor with a bone handle, two hollow armllets and a bronze spit.⁴²⁹ These objects point to the Certosa phase. This would also be the time frame for Grave 13/5 at Preloge, which contained several bronze trilobate and one bilobate arrowhead as well as several iron arrowheads (fig. 51: 6–8), a spearhead and a rectangular belt clasp. Less reliable is the contents of Grave IV/43 at Preloge, mentioned above in connection with the lugged axe. The two arrowheads published within the group (fig. 51: 9, 10) are kept at the museum in Ljubljana. Furthermore, a large iron arrowhead is mentioned by Goldberg in his description of, supposedly cremation, Grave I/3 at Preloge, found at the edge of the tumulus. The grave further contained two crushed black vessels, a "hunting knife" or a dagger, two bracelets and two fibulae; these finds are now missing.⁴³⁰

Bronze flat bilobate arrowheads appeared in the Dolenjska region already in Urnfield culture contexts, namely in the cemetery at Mestne njive in Novo mesto.⁴³¹ In Early Hallstatt contexts, they were found in a grave with a bowl-shaped helmet from Libna,⁴³² in a grave with a cuirass from Stična⁴³³ and at Dobrnič.⁴³⁴ Iron bilobate arrowheads are known in the Late Hallstatt

⁴²⁶ Guštin 1991, T. 4: 3, 18: 2, 25: 8, 26: 1, 27: 11, 12, 30: 2, 3.

⁴²⁷ See for example De Marinis 1977, Pl. 2: 9, 3: 4.

⁴²⁸ *Preloge, Gr. I/3, IV/43, 2/13, 2/38, 13/5*: Hencken 1978, Figs. 85g,j, 364m; Tecco Hvala/Dular/Kocuvan 2004, T. 26: 26–30, 36: 19–21; 67A: 6–13.

⁴²⁹ Tecco Hvala/Dular/Kocuvan 2004, 35, 39.

⁴³⁰ Hencken 1978, 12 f.

⁴³¹ Knez 1984, T. 3: 8; Križ et al. 2009, 235, Cat. Nos. 4.2.30, 35a–c.

⁴³² Guštin 1976, T. 57: 2; Guštin/Preložnik 2005, 133 f, Fig. 21: 16, n. 23.

⁴³³ Gabrovec et al. 2006, T. 13: 40–49, 211.

⁴³⁴ Parzinger 1988–1989, T. 41: 1–13.

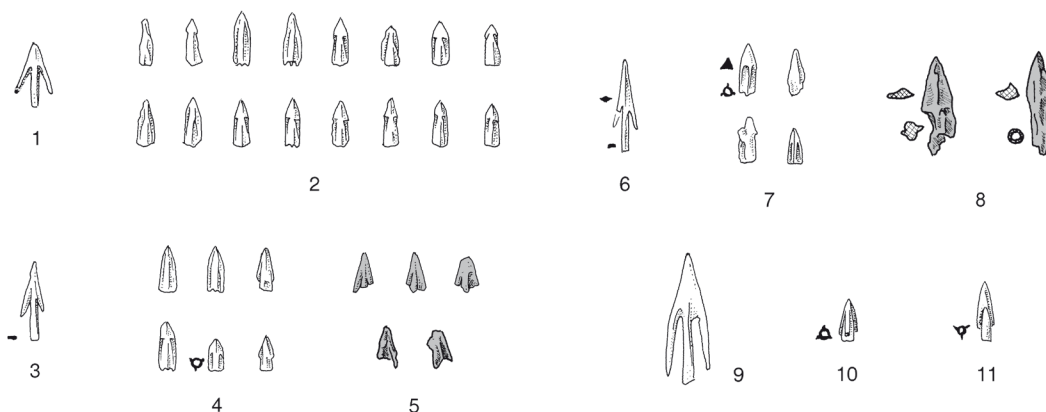

Sl. 51: Dvokrilne in trirobe puščične osti z Magdalenske gore. 5, 8 = železo, ostalo = bron. M. = 1:4.
 Fig. 51: Bilobate and trilobate arrowheads from Magdalenska gora. 5, 8 = iron, other = bronze. Scale = 1:4.
 1, 2 – Preloge, gr. 2/13; 3–5 – Preloge, gr. 2/38; 6–8 Preloge, gr. 13/5; 9, 10 – Preloge, gr. IV/43;
 11 – najdba brez znane grobne celote v PM / find without preserved context kept in the PM.

se bronaste trirobe puščične osti povezujejo s skitskimi vplivi oz. vdori lokostrelskih ljudstev, ki so razširila iz severnopontskih dežel prek panonsko-karpatskega prostora.⁴³⁶ Trirobe puščične osti na Dolenjskem večkrat zasledimo skupaj s skitsko konjsko opremo in konji, hkrati pa tudi s tipično lokalnim orožjem (tulasto sekiro, dvogrebenasto čelado), kar kaže na prepletanje prvin različnega kulturnega izvora. Kot je pokazala Teržanova, jih v jugovzhodnem alpskem svetu lahko zaznamo že ob koncu starejšega halštatskega obdobja na naseljih, v grobovih pa se pojavljajo v mlajšem halštatskem času.⁴³⁷ Človeška stegenica, odkrita v grobu na Vačah, v katero je zadržana triroba puščična ost, dokazuje, da je bilo tako orožje uporabljeno v boju.

V magdalenskogorskih grobovih nastopajo vse tri vrste puščičnih osti skupaj – bronaste in železne dvo-krilne ter trirobe oblike (sl. 51), kar daje vtis nekakšne “trofejne” zbirke. V primerjavi z drugimi vrstami orožja (sulicami, kopji in sekirami) pa niso ravno pogoste.

Lokostrelsko orožje zasledimo v različnih kulturnih okoljih. Skitske trirobe puščične osti nastopajo med daritvami v svetiščih v kontinentalni Grčiji in južni Italiji,⁴³⁸ najdene pa so bile tudi v nekaterih drugih središčih na Apeninskem polotoku (Spina, Numana, Cerveteri).⁴³⁹

304 s, Abb. 10: 2-17, 27: 1c; Pazinger/Nekvasil/Barth 1995, 61 ss, Abb. 22; Hansen 2010, 171 ss, Tab. 22, Karte 27 (tip 1).

⁴³⁶ Párducz 1973, 32, Karte 1; Gabrovec 1964–1965a, 35 ss; id. 1999, 186; Chochorowski 1985, 247 ss; Teržan 1998, 530 ss, Abb. 8, Liste 1; ead. 2008, 286 ss, 319; Hellmuth 2007b; ead. 2010, 211 ss, Abb 264–266; Kemenczei 2009, T. 12: 1, 16: 1, 17:1,2 itd.

⁴³⁷ Teržan 1998, 521 ss, Abb. 10, T. 5: 3,10,13-24, 7: 4, 9: 4, 11: 1-21.

⁴³⁸ Baitinger 2011, Abb. 8, 32, 63.

⁴³⁹ Hellmuth 2007a, 201 ss, Abb. 1: a,b, Abb. 8: 1-5.

culture in the northern Alps and in western Pannonia.⁴³⁵ Bronze trilobate arrowheads, on the other hand, are commonly interpreted as a manifestation of the Scythian influence or a penetration of the archer people that spread from the northern Pontus via the Pannonian and Carpathian areas.⁴³⁶ In Dolenjska, trilobate arrowheads were found in several graves together with Scythian horse gear and horses, as well as typically local weapons (socketed axe, double-crested helmet), which indicates an intermingling of elements from different cultural circles. Teržan observed that trilobate arrowheads appeared in the south-eastern Alpine area already at the end of the Early Hallstatt period in settlements, while those documented in graves do not predate the Late Hallstatt period.⁴³⁷ The trilobate arrowhead embedded in the human femur, found in a grave at Vače, is evidence of the weapon being used in battle.

In the graves at Magdalenska gora, all three types of arrowheads – bronze and iron bilobate as well as trilobate (fig. 51) – appear together, which indicates a sort of a “trophy” collection. Compared to other types of arms (spears, javelins and axes), arrows were not very numerously represented.

Archery weapons were documented in various cultural milieus. Scythian trilobate arrowheads appear among the offerings in the sanctuaries in continental

⁴³⁵ Jerem 1968, 184, Fig. 24: 31/5, n. 72; Egg 1985a, 304 f, Abb. 10: 2-17, 27: 1c; Pazinger/Nekvasil/Barth 1995, 61 ff, Abb. 22; Hansen 2010, 171 ff, Tab. 22, Karte 27 (Type 1).

⁴³⁶ Párducz 1973, 32, Karte 1; Gabrovec 1964–1965a, 35 f; id. 1999, 186; Chochorowski 1985, 247 ff; Teržan 1998, 530 ff, Abb. 8, Liste 1; ead. 2008, 286 ff, 319; Hellmuth 2007b; ead. 2010, 211 ff, Abb 264–266; Kemenczei 2009, T. 12: 1, 16: 1, 17:1,2.

⁴³⁷ Teržan 1998, 521 ff, Abb. 10, T. 5: 3,10,13-24, 7: 4, 9: 4, 11: 1-21.

Poleg samih predmetov so znane tudi upodobitve orožja v situlski umetnosti, kjer so podobe sicer stilizirane, a vendarle do neke mere realistične. Najstarejše pričevanje v jugovzhodnih Alpah predstavlja fragment čelade iz groba 4/1 z Laščika na Magdalenski gori iz stopnje Stična 1, ki prikazuje ščitonosce, opremljene s skledasto čelado in eno veliko sulico z močnim sredinskim rebrom.⁴⁴⁰ Več upodobitev je znanih iz časa certoške stopnje. Na situli iz gomile 2 na Prelogah (rekonstruirana grobna celota 2/a) lahko opazimo moški figuri z dvema sulicama s krajšim listom deltoide oblike.⁴⁴¹ Uporabo kopja v boju in lovu prikazuje prizora na pasnih sponah z Vač in iz Zagorja.⁴⁴² Tudi na bronasti votivni ploščici iz svetišča v Altinu, datirani v prvo polovico 5. st. pr. n. št., je upodobljen konjenik, ki meče kopje.⁴⁴³ Ta pričevanja podkrepljujejo domnevo, da so bila v severnojadranskem zaledju v uporabi kopja za napad z razdalje. Prizor z lokostrelcem zasledimo npr. na cisti iz Kleinkleina (Kröll-Schmidkogel),⁴⁴⁴ na pasni sponi z Molnika⁴⁴⁵ ter na situlah iz Novega mesta⁴⁴⁶ in Dolenjskih Toplic.⁴⁴⁷ Na teh prizorih je upodobljen lov. Znana je tudi bronasta statueta lokostrelca iz svetišča v Altinu, datirana v drugo četrtino 5. st. pr. n. št., ki upodablja dolgolasega moškega v hlačah in v značilni drži v pokleku, z napetim lokom v rokah ter z naglavnim pokrivalom v podobi ptice; statueto pa interpretirajo v kontekstu grških vplivov kot Parisa – protagonista trojanskega mita.⁴⁴⁸ Lok je atribut tudi nekaterih drugih grških herojev in božanstev (Artemide, Herakleja, Apolona, Kupida itd.).⁴⁴⁹ Upodobitve lokostrelcev v hlačah, ki se pojavljajo na grški slikani keramiki iz časa po perzijskih vojnah, razlagajo kot Skite ali Perzijce. V antičnih pisnih virih se skitski lokostrelci omenjajo tudi kot najemniki v grški vojski.⁴⁵⁰

Iz povedanega sledi, da pomen orožja ni enoznačen in da obstaja več možnih razlag, odvisno od konteksta.

⁴⁴⁰ Gabrovec 1964–1965b; Frey 1969, T. 58; Egg 1980; Tecco Hvala/Dular/Kocuvan 2004, sl. 15, T. 1: 1; Turk 2005, sl. 66, 67.

⁴⁴¹ Stare F. 1955c, pril. 4; Lucke/Frey 1962, T. 36, 69; Tecco Hvala/Dular/Kocuvan 2004, pril. 2; Turk 2005, sl. 37.

⁴⁴² Stare F. 1952, T. 3; Gabrovec 1966b, T. 7: 3; Turk 2005, sl. 43, 58: 1, 88, 92; Fossati 2006, 31ss, Fig. 6.

⁴⁴³ Capuis/Gambacurta 2001, Fig. 1c, 7a; Tirelli 2005, 305, Fig. 5.

⁴⁴⁴ Frey 1969, 70, Abb. 39: 2.

⁴⁴⁵ Puš 1991, hrbtna platnica; Teržan 1998, 530, Abb. 10; Turk 2005, 31 ss, sl. 45, 87.

⁴⁴⁶ *Kapiteljska njiva, gr. 3/12*: Križ 1997, pril. 3; Turk 2005, sl. 44, 45, 87.

⁴⁴⁷ *Dolenjske Toplice, gr. 2/23*: Egg/Eibner 2005, 193 ss, Abb. 4: spodnji friz levo spodaj, Abb. 7.

⁴⁴⁸ Tirelli/Cipriano 2001, 46 s, Fig. 10a–c; Capuis/Gambacurta 2001, Fig. 2c, 9a; Tirelli 2003, 78 s, Fig. 18; Tirelli 2005, 309 ss, Fig. 11–13, Tav. 10b; Sparkes 2011, 56, Fig. 15.

⁴⁴⁹ Snodgrass 1967, 39, 81, 99 s; Bianchi Bandinelli/Giuliano 1973 (2000), 116, Fig. 136; Kull 1997, 296 ss, Abb. 50.

⁴⁵⁰ Snodgrass 1967, 83 s, Fig. 38, 40, 46.

Greece and southern Italy,⁴³⁸ while they were also found in several centres on the Apennine Peninsula (Spina, Numana, Cerveteri).⁴³⁹

Apart from the objects themselves, this kind of armament also appears on objects of the situla art. Their depictions are stylized, but nevertheless revealing to a degree. The earliest such testimony in the south-eastern Alps is the fragment of a helmet from Grave 4/1 at Laščik, dated to the Stična 1 phase. It shows shield-bearers wearing bowl-shaped helmets and holding large spears with a pronounced midrib.⁴⁴⁰ More depictions are available from the Certosa phase. The situla from Tumulus 2 at Preloge (reconstructed Grave Group 2/a) shows two male figures, each holding a spear with a short deltoid blade.⁴⁴¹ The use of javelins in battle and hunting is depicted on two belt clasps from Vače and Zagorje, respectively.⁴⁴² A horseman throwing a javelin is also shown on the bronze votive plaque from the sanctuary at Altino, dated to the first half of the fifth century BC.⁴⁴³ These examples confirm the supposition of the use of javelins for long-range warfare in the hinterland of the northern Adriatic.

Depictions of archers are known from Kleinklein (on a cist from the Kröll-Schmidkogel Tumulus),⁴⁴⁴ Molnik (on a belt clasp)⁴⁴⁵ and on situlae from Novo mesto⁴⁴⁶ and Dolenjske Toplice.⁴⁴⁷ These depictions represent hunting-scenes. Also known is a bronze statuette of an archer from the sanctuary at Altino, dated to the second quarter of the fifth century BC. The archer is shown as a man with long hair and in a characteristic genuflected pose with a drawn bow in his hands, wearing trousers and hawk-shaped headgear. The statuette is interpreted, in the context of the Greek influence, as Paris – protagonist of the Trojan myth.⁴⁴⁸ Having said that, the bow can be the attribute of other Greek heroes and deities (Artemis, Herakles, Apollo, Cupid and

⁴³⁸ Baitinger 2011, Abb. 8, 32, 63.

⁴³⁹ Hellmuth 2007a, 201 ff, Abb. 1: a,b, Abb. 8: 1-5.

⁴⁴⁰ Gabrovec 1964–1965b; Frey 1969, T. 58; Egg 1980; Tecco Hvala/Dular/Kocuvan 2004, Abb. 15, T. 1: 1; Turk 2005, Figs. 66, 67.

⁴⁴¹ Stare F. 1955c, App. 4; Lucke/Frey 1962, T. 36, 69; Tecco Hvala/Dular/Kocuvan 2004, Beil. 2; Turk 2005, Fig. 37.

⁴⁴² Stare F. 1952, T. 3; Gabrovec 1966b, T. 7: 3; Turk 2005, Figs. 43, 58: 1, 88, 92; Fossati 2006, 31ff, Fig. 6.

⁴⁴³ Capuis/Gambacurta 2001, Figs. 1c, 7a; Tirelli 2005, 305, Fig. 5.

⁴⁴⁴ Frey 1969, 70, Abb. 39: 2.

⁴⁴⁵ Puš 1991, on the back cover; Teržan 1998, 530, Abb. 10; Turk 2005, 31 ff, Figs. 45, 87.

⁴⁴⁶ *Kapiteljska njiva, Gr. 3/12*: Križ 1997, App. 3; Turk 2005, Figs. 44, 45, 87.

⁴⁴⁷ *Dolenjske Toplice, Gr. 2/23*: Egg/Eibner 2005, 193 ff, Abb. 4: bottom left on the lower frieze, Abb. 7.

⁴⁴⁸ Tirelli/Cipriano 2001, 46 f, Fig. 10a–c; Capuis/Gambacurta 2001, Figs. 2c, 9a; Tirelli 2003, 78 f, Fig. 18; Tirelli 2005, 309 ff, Figs. 11–13, Tav. 10b; Sparkes 2011, 56, Fig. 15.

Orožje se je uporabljalo tako v boju kot v lovu in v ritualih žrtvovanja, umetniške upodobitve pa si je moč razlagati kot odsev resničnega življenja ali kot posnemanje ikonografije in mitoloških vsebin vzhodnega Sredozemlja.⁴⁵¹

4.1.3 BODALA IN MEČI

BODALA

Od napadalnega orožja za boj mož na moža so med magdalenskogorskimi najdbami zastopana še bodala in meči. Narodni muzej v Ljubljani hrani bronasto bodalo, ki domnevno izvira iz okolice Magdalenske gore; natančnejši najdiščni podatki niso znani.⁴⁵² V Naravoslovnem muzeju na Dunaju so v sklopu groba 13/10 s Prelog inventarizirani ostanki enega bodala z železnim rezilom in bronasto nožnico z masivnim bikoničnim zaključkom.⁴⁵³ Podobno bodalo je bilo odkrito tudi med izkopavanji vojvodinje Mecklenburške na Magdalenski gori leta 1905 ali 1908.⁴⁵⁴

Bronasto bodalo iz ljubljanskega muzeja se po oblikovnih značilnostih uvršča med jezičastoročajne primerke vrste Peschiera, ki se v jugovzhodnih Alpah pojavljajo v depojih iz časa Bd D in Ha A.⁴⁵⁵

Bodalo z železnim rezilom in bronasto nožnico (*sl. 52: 1*), ki ga hrani dunajski muzej, je bilo najdeno v žganem grobu 13/10 s Prelog na severozahodnem robu gomile.⁴⁵⁶ Po spremnih pridatkih, med katere spadajo dve sulični osti, nož, velik brusni kamen, železna rombična pasna spona in dva apulska kraterja, ga lahko datiramo na konec stopnje Stična ali na začetek stopnje kačastih fibul.⁴⁵⁷

Dobro ohranjeno je moralo biti bodalo v grobu I/3 s Prelog, ki je menda ležal na samem robu gomile in naj bi bil žgan, čeprav bi po dimenzijah grobne jame (2,8 x 1,2 m) lahko bil tudi skeleten. Goldberg je v poročilu podal mere bodala (45 cm dolžine) in skico, ki jo je v prerinu objavil Hencken (*sl. 52: 2*), na kateri je viden kro-

⁴⁵¹ Frey 1969, 70 s, Abb. 38: 1, 39: 1,2; Kull 1997, Abb. 47; Eibner 2004, 621 ss; Egg/Kramer 2005, 29, Abb. 23, 24; Turk 2005, 3 s, sl. 46–48; Tirelli 2005, 309 ss; Fossati 2006, 31 ss; Gleirscher 2009.

⁴⁵² Šinkovec 1995, 97 s, T. 27: 190 z navedbo literature; najstarejši vir predstavlja zapis Müllnerja v reviji *Argo* 3, 1894, 120, T. 10: 32. Glej še Tecco Hvala/Dular/Kocuvan 2004, T. 165: 1.

⁴⁵³ Tecco Hvala/Dular/Kocuvan 2004, T. 68: 4.

⁴⁵⁴ Hencken 1978, Fig. 7a.

⁴⁵⁵ Čerče/Šinkovec 1995, sl. 37: 4, 40: 2, T. 62: 19,20, 75: 24, 89: 7,8, 142A: 1,2; Šinkovec 1996, 142 s.

⁴⁵⁶ Glej tu poglavje 3.2.1 o žganih pokopih z leseno podlogo. Lega groba v gomili je razvidna iz rekonstruiranega tlorisa na osnovi Brattinovih merskih podatkov: Tecco Hvala/Dular/Kocuvan 2004, 55, sl. 28, 29.

⁴⁵⁷ Gabrovec 1987, 42 ss, 78, sl. 2; Turk/Murgelj 2008, 168.

others).⁴⁴⁹ Trousers-wearing archers depicted on Greek painted ware from the time after the Persian wars are interpreted as Scythians or Persians, while we know of Scythian archers as mercenaries in the Greek army from ancient written sources.⁴⁵⁰

In conclusion, finds of weapons can be interpreted in several different ways, depending on the context. They may be used in battle, hunting and sacrificial rituals, as shown by the artistic depictions, which may be interpreted as a reflection of reality or as an imitation of the iconographic and mythological programmes of the eastern Mediterranean.⁴⁵¹

4.1.3 DAGGERS AND SWORDS

DAGGERS

Close combat arms from Magdalenska gora further include daggers and swords. One dagger, made of bronze, is kept in the National Museum in Ljubljana. It was supposedly found in the vicinity of Magdalenska gora, though no additional data is known on the findspot.⁴⁵² The other dagger was found in Grave 13/10 at Preloge, the contents of which are kept in the Museum of Natural History in Vienna.⁴⁵³ This dagger had an iron blade and was found with a bronze scabbard with a solid biconical chape. A similar dagger was found during the excavations at the site by the Duchess of Mecklenburg either in 1905 or 1908.⁴⁵⁴

The bronze dagger from the museum in Ljubljana is a Peschiera type flange-hilted dagger, a type that appears in the south-eastern Alpine area in hoards from Bd D and Ha A.⁴⁵⁵

The dagger with an iron blade and a bronze scabbard (*fig. 52: 1*), kept at the museum in Vienna, was found in cremation Grave 13/10 at Preloge, on the north-western edge of the tumulus.⁴⁵⁶ The grave further revealed two spearheads, a knife, a large whetstone, an

⁴⁴⁹ Snodgrass 1967, 39, 81, 99 f; Bianchi Bandinelli/Giuliano 1973 (2000), 116, Fig. 136; Kull 1997, 296 ff, Abb. 50.

⁴⁵⁰ Snodgrass 1967, 83 f, Figs. 38, 40, 46.

⁴⁵¹ Frey 1969, 70 f, Abb. 38: 1, 39: 1,2; Kull 1997, Abb. 47; Eibner 2004, 621 ff; Egg/Kramer 2005, 29, Abb. 23, 24; Turk 2005, 31 f, Figs. 46–48; Tirelli 2005, 309 ff; Fossati 2006, 31 ff; Gleirscher 2009.

⁴⁵² Šinkovec 1995, 97 f, T. 27: 190 with references. This dagger was first mentioned by Müllner in *Argo* 3, 1894, 120, T. 10: 32. See also Tecco Hvala/Dular/Kocuvan 2004, T. 165: 1.

⁴⁵³ Tecco Hvala/Dular/Kocuvan 2004, T. 68: 4.

⁴⁵⁴ Hencken 1978, Fig. 7a.

⁴⁵⁵ Čerče/Šinkovec 1995, Figs. 37: 4, 40: 2, T. 62: 19,20, 75: 24, 89: 7,8, 142A: 1,2; Šinkovec 1996, 142 f.

⁴⁵⁶ See here Chapter 3.2.1 on cremation graves with wooden bedding. The grave position in the tumulus is shown on the ground-plan reconstructed on the basis of Brattina's measurements: Tecco Hvala/Dular/Kocuvan 2004, 55, Abb. 28, 29.

glast zaključek nožnice in ob strani okova za pripenjanje. Pridatki (bodalo, železna puščična ost, črni posodi, fibuli in zapestnici) so pogrešani,⁴⁵⁸ vendar obstajajo indici, da je vojvodinja bodalo iz tega groba nemara podarila nemškemu cesarju Wilhelmu II.⁴⁵⁹

⁴⁵⁸ Hencken 1978, 11 ss.

⁴⁵⁹ V berlinski muzej so prišli nekateri dragoceni kosi,

iron rhombic belt clasp and two Apulian *kratere*, which date the dagger into the end of the Stična or the beginning of the Serpentine Fibulae phase.⁴⁵⁷

Another dagger was found in Grave I/3 at Preloge, which must have been well preserved. The grave was reportedly located on the edge of the tumulus and con-

⁴⁵⁷ Gabrovec 1987, 42 ff, 78, Fig. 2; Turk/Murgelj 2008, 168.

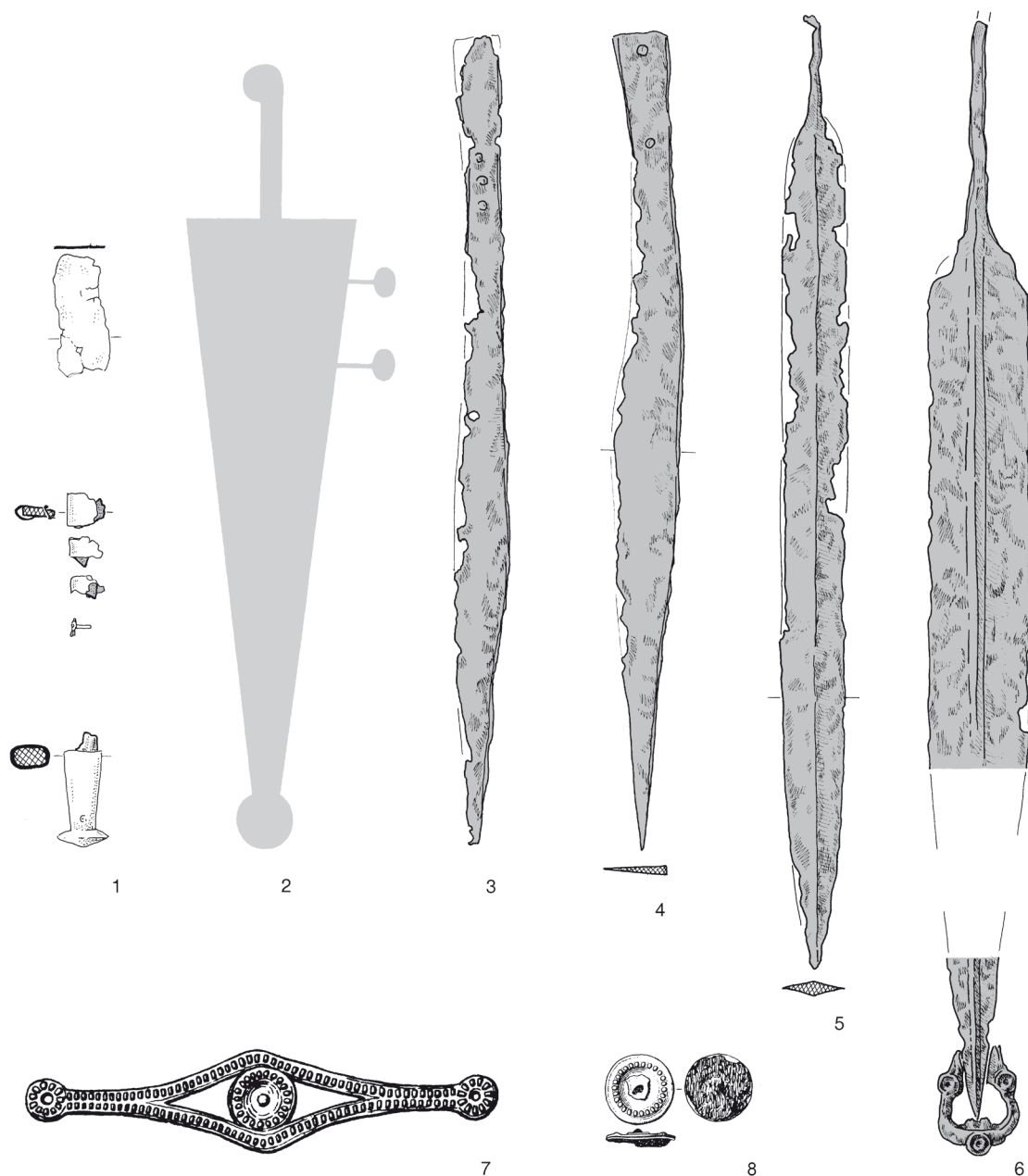

Sl. 52: Bodala in meči z Magdalenske gore. M. = 1:4 (1-6) in 1:1 (7, 8).

Fig. 52: Daggers and swords from Magdalenska gora. Scales = 1:4 (1-6) and 1:1 (7, 8).

1 - Preloge, gr. 13/10; 2 - Preloge, gr. I/3; 3, 4 - najdbi brez znanih grobnih celot v PM / finds without preserved context kept in the PM; 5 - Laščik, gr. V/29; 6, 8 - Laščik, gr. V/19-20; 7 - Laščik, gr. V/26a.

Takih bodal je bilo na teritoriju dolenske halštatske skupnosti odkritih kar nekaj (Vače, Stična, Veliki Vinji vrh oz. Šmarjeta, Mihovo in Podzemelj), grobne celote pa največkrat niso znane. Večina jih ima železna rezila in bronaste nožnice s kroglastim ali bikoničnim zaključkom, pri strani pa okove za pritrditev na pas. Zbral in analiziral jih je Frey, ki je v načinu nošnje ob pasu videl karakterističen element skitskih *akinakai*.⁴⁶⁰ Vendar so se podobno nosila tudi picenska bodala, ki so zastopana v grobovih iz druge polovice 7. st. pr. n. št.⁴⁶¹ Povezavo s tem prostorom nakazuje še širokolistna sulična ost (sl. 48: 1), ki je bila na Magdalenski gori najdena skupaj z bodalom, južnoitalski element predstavlja tudi apulska kraterja iz te grobne celote (sl. 29).

MEČI

Med magdalenskogorskimi najdbami iz Mecklenburške zbirke je moč prepoznati dva primerka kratkih enoreznih mečev, vendar je njuna provenienca vprašljiva. En primerka je zvit (sl. 52: 3), izviral naj bi iz gomile IV na Prelogah, medtem ko o okoliščinah odkritja drugega primerka ni nikakršnih podatkov (sl. 52: 4).⁴⁶² Po obliki sta podobna nožem s ploščatim nastavkom in zakovicami, le da sta enkrat daljša (sl. 53: 4, 5). Guštin domneva, da so se tovrstni meči razvili iz starejših "ilirskih" mečev oz. *mahair*,⁴⁶³ pojavljajo pa se v okviru "vojaškega horizonta" 5. in 4. st. pr. n. št. med Donavo in Padom, kot ga je označila Teržanova.⁴⁶⁴

Poleg teh so na Magdalenski gori zabeleženi tudi pravi latenski meči. Štirje primerki naj bi bili najdeni v gomili V na Laščiku, od teh je eden pripadal najbogatejšemu grobu, kar so jih tukaj odkrili, tj. grobu V/29, o katerem je Goldberg obširneje poročal, kljub temu

med katerimi so omenjena tudi bodala: Gabrovec 1978, 128, 130; id. 2008, 19; Weiss 1999, Abb 66c. Zadevo zdaj preiskujeta Božič in Weiss in pripravljata objavo o svojih izsledkih v zvezi z grobom I/3 z Magdalenske gore.

⁴⁶⁰ Frey 1980a, 337 ss, Abb. 3–7.

⁴⁶¹ Stary 1981, 262; Beinhauer 1985, 552, 553, Typentafel C: 57 in D: 66, T. 58: 697, 60: 724, 87: 986, 118: 1313 ipd. ter 104: 1154; Bergonzi 1992, 63, Fig. 2; *Eroi e regine. Piceni Popolo d'Europa* 2001, 256, Fig. 464. Razvoj oborožitve v Novilari kaže, da sta stožčasto čelado in *mahairo* v mlajših fazah zamenjali sestavljena čelada in bodalo. Take čelade in *mahaire* pa so poznane tudi na Dolenjskem, zato se v tem pogledu zdi navezava dolenskih bodal na picensko idejo bližja: Gabrovec 1987, 62.

⁴⁶² Hencken 1978, Fig. 99a,f, 365i; Guštin 1984, 345 s, Abb. 29, Liste 6. V Narodnem muzeju v Ljubljani je zastopan enak zviti primerka enoreznega meča iz Vinice (Gabrovec 1966c, T. 20: 1), viniško gradivo pa hrani tudi Peabodyjev muzej, kjer je pomešano z najdbami iz drugih nekropol, ki jih je kopala vojvodinja Mecklenburška (Božič 2010).

⁴⁶³ Guštin 1974a, 81, op. 14; id. 1984, 345.

⁴⁶⁴ Teržan 1977, 10 ss, op. 11, sl. 4: 12; De Marinis 1977, 36, op. 77.

tained a cremation burial, though the size of the grave pit (2.8 x 1.2m) could also have fitted an inhumation. Goldberg noted the length of the dagger (45cm) and drew a sketch. A copy of the sketch was published by Hencken (fig. 52: 2) and shows a globular chape of the scabbard and two side fittings for attachment. The grave goods (dagger, iron arrowhead, two black vessels, two fibulae and two bracelets) are now missing.⁴⁵⁸ As for the dagger, there are reasons to suspect that the Duchess offered it to the German Emperor Wilhelm II.⁴⁵⁹

There were several such daggers found on the territory of the Dolenjska Hallstatt community (Vače, Stična, Veliki Vinji vrh (Šmarjeta), Mihovo and Podzemelj), though their grave groups are for the most part unknown. Most have iron blades and bronze scabbards with either a globular or biconical chape as well as side fittings by way of which they were attached to the belt. The daggers were analysed by Frey, who saw the manner in which they were carried on the belt as a characteristic element of the Scythian *akinakai*.⁴⁶⁰ However, a similar manner was observed also on the daggers from Picenum, where they represented a frequent good in graves from the second half of the seventh century BC.⁴⁶¹ A connection between Picenum and Dolenjska is further indicated by a spearhead with a wide blade (fig. 48: 1), found at Magdalenska gora together with a dagger and another south Italian element, namely two Apulian *kratere* (fig. 29).

SWORDS

The finds from Magdalenska gora in the Mecklenburg collection include two examples of short single-edged swords, though their provenance is problematic. One of the swords is bent (fig. 52: 3) and was reportedly found in Tumulus IV at Preloge, while the other sword is without find data (fig. 52: 4).⁴⁶² They are similar in

⁴⁵⁸ Hencken 1978, 11 ff.

⁴⁵⁹ Several valuable objects, including daggers, came to the museum in Berlin: Gabrovec 1978, 128, 130; id. 2008, 19; Weiss 1999, Abb 66c. Božič and Weiss devoted their attention to this subject, intending to publish their findings on Grave I/3 from Magdalenska gora.

⁴⁶⁰ Frey 1980a, 337 ff, Abb. 3–7.

⁴⁶¹ Stary 1981, 262; Beinhauer 1985, 552, 553, Typentafel C: 57, D: 66, T. 58: 697, 60: 724, 87: 986, 118: 1313 and 104: 1154; Bergonzi 1992, 63, Fig. 2; *Eroi e regine. Piceni Popolo d'Europa* 2001, 256, Fig. 464. The development of armament in Novilari shows that conical helmet and *machaira* sword were later replaced by composite helmet and dagger. These types of helmets and sword are also known in the Dolenjska region, wherefore it seems more plausible to connect the Picene and Dolenjska daggers in conception: Gabrovec 1987, 62.

⁴⁶² Hencken 1978, Figs. 99a,f, 365i; Guštin 1984, 345 f, Abb. 29, Liste 6. One bent example of a single-edged sword is known from Vinica, kept in the museum in Ljubljana (Gab-

pa situacija ni povsem jasna. Šlo naj bi za pokop dveh moških z negovskima čeladama in štirih konj. Kratek meč (sl. 52: 5) je menda ležal na lisi žganine skupaj s štirimi suličnimi ostmi, brusnim kamnom, bronasto cisto in slabo ohranjeno situlo, konjsko opremo, spiralno narokvico, dvema pasnima sponama ter z bronastim žezlom.⁴⁶⁵ Drug primerek meča je prav tako izpričan v dvojnem grobu (V/19–20), ki je po Goldbergovih navedbah ležal blizu sredine gomile ter 20 ali 50 cm pod površjem. Grob so menda poškodovale drevesne korenine ali morebitni divji kop; v njem so naleteli na slabo ohranjeni okostji, ki sta ležali v isti smeri, med njima pa so bili položeni 83 cm dolg meč (sl. 52: 6), dve sulični osti 24 in 33 cm dolžine ter 19 cm dolga plavutasta sekira.⁴⁶⁶ Železen meč z zlatim okraskom na ročaju, ki je omenjen v enojnem grobu iz te gomile (V/26a), ni objavljen. Med pridanke tega groba so po Goldbergovem pričevanju spadali 19,5 cm dolga pasna spona, nekakšna bronasta igla ali konica bodala (dolga 17,5 cm), dve sulični osti (ena naj bi merila 47 cm) ter ukrivljen nož. Nekateri od teh predmetov v objavi manjkajo ali pa ne ustrezajo navedenim meram. Od meča je objavljen le bronast okrasek rombične oblike, izdelan v predrti tehniki, z okroglo ploščico v sredini (sl. 52: 7). Enaka okrogla ploščica s premerom 1 cm, ki ima pozlato in železno zakovico (sl. 52: 8), je objavljena kot okrasni element meča v grobu V/19–20.⁴⁶⁷ Ti trije meči so za zdaj edini znani zgodnjelatski primerki na teritoriju dolenjske halštatske skupnosti in zagotovo predstavljajo import.⁴⁶⁸ Analogije za okrasna elementa iz grobov V/19–20 in V/26a lahko najdemo v srednjem Porenju, v Bescheidu.⁴⁶⁹ Nožnica meča iz groba V/19–20 s tremi okroglimi vdolbinami (za korale?) spominja na zgodnjelatske primerke s srednjeevropskega prostora.⁴⁷⁰ Dobro paralelo za grobno celoto V/29 pa predstavlja nedavno odkritje v Dürrnbergu, kjer je bil v enem od skeletnih grobov najden zgodnjelatski meč v kombinaciji z negovsko čelado.⁴⁷¹

V magdalenskogorskih gomilah so zabeleženi še meči iz poznolatskega obdobja. Primerek iz gomile V na Laščiku je bil zvit in je pripadal plitvo ležečemu grobu V/42 na vzhodnem robu, ki je domnevno predstavljal žgani pokop, saj kosti niso omenjene. V ta grobni sestav so spadali tudi širokolistna sulična ost, okrogla ščitna grba, nož z zanko na koncu ročaja in fragmenta sivorjave posode, kar kaže na pokop v času

⁴⁶⁵ Hencken 1978, 36 ss, Fig. 144d.

⁴⁶⁶ *Ibid.*, 33 s, Fig. 125a.

⁴⁶⁷ *Ibid.*, 35, Fig. 125f, 130c.

⁴⁶⁸ Guštin 1984, 307; Gabrovec 1987, 72, sl. 6: 3; Božič 1987, 893; *id.* 1991, 473.

⁴⁶⁹ Haffner/Läge 2008–2009, 63 ss, Abb. 40.

⁴⁷⁰ Frey 1987, 18, Fig. 9; Haffner 1992, 48 ss, Abb. 20, 26, 40, 44, 54, Falttaf. 1,2; Egg/Hauschild/Schönfelder 2006, 182 ss, Tab. 1, Abb. 10.

⁴⁷¹ Moser 2009, 104 s, Abb. 3 (SK V), 4,5.

form to the knives with a flat tang and rivets, only twice as long (figs. 53: 4, 5). Guštin supposes that this type of swords developed from the earlier "Illyrian" swords or *machairas*.⁴⁶³ They appear in the "horizon of warrior tombs" of the fifth and fourth centuries BC between the Danube and the Po, as determined by Teržan.⁴⁶⁴

Apart from these, Magdalenska gora also revealed real La Tène swords. Four examples were found in Tumulus V at Laščik. One of them belonged to the richest grave of the tumulus, namely Grave V/29, of which Goldberg wrote more extensively, though the situation is still not quite clear. It was supposedly a burial of two males, with Negova helmets, and four horses, whereby the short sword (fig. 52: 5) was found on a patch of burnt remains together with four spearheads, a whetstone, a bronze cist and a poorly preserved situla, horse gear, a spiral armlet, two belt clasps and a bronze mace.⁴⁶⁵ The second example of a La Tène sword was also found in a double burial (V/19–20), which was situated near the centre of the tumulus and 20 or 50cm under the surface, according to Goldberg. The grave was reportedly damaged either by tree roots or by treasure hunters. The poorly preserved skeletons had the same orientation. Placed between them was a 83cm long sword (fig. 52: 6), two spearheads, 24 and 33cm in length, respectively, and a 19cm long winged axe.⁴⁶⁶ An iron sword with gold decoration on the hilt is mentioned in connection with a single burial from the tumulus (V/26a), though it is not published. Other goods in this grave are a 19.5cm long belt clasp, a sort of a bronze pin or dagger point (17.5cm long), two spearheads (one measuring 47cm in length) and a curved knife. Some of these objects are either missing in the publication or do not correspond to the descriptions. Of the sword, only the bronze rhombic openwork decoration, with a disc in the centre (fig. 52: 7), is published. A disc of the same shape and measuring 1cm in diameter, with gilding and an iron rivet (fig. 52: 8), was published as a decorative element of a sword in Grave V/19–20.⁴⁶⁷ At the present state of knowledge, these three swords are the only known examples of Early La Tène swords on the territory of the Dolenjska Hallstatt community and certainly represent imports.⁴⁶⁸ Analogies for the decorative elements from Graves V/19–20 and V/26a can be found in the middle Rheinland, at Bescheid.⁴⁶⁹ The scabbard of the sword

rovec 1966c, T. 20: 1). A large part of the material from Vinica is kept in the Peabody Museum, where it is intermingled with the finds from other cemeteries excavated by the Duchess of Mecklenburg (Božič 2010).

⁴⁶³ Guštin 1974a, 81, n. 14; *id.* 1984, 345.

⁴⁶⁴ Teržan 1977, 10 ff, n. 11, Fig. 4: 12; De Marinis 1977, 36, n. 77.

⁴⁶⁵ Hencken 1978, 36 ff, Fig. 144d.

⁴⁶⁶ *Ibid.*, 33 f, Fig. 125a.

⁴⁶⁷ *Ibid.*, 35, Figs. 125f, 130c.

⁴⁶⁸ Guštin 1984, 307; Gabrovec 1987, 72, Fig. 6: 3; Božič 1987, 893; *id.* 1991, 473.

⁴⁶⁹ Haffner/Läge 2008–2009, 63 ff, Abb. 40.

stopnje Mokronog IIIa.⁴⁷² Verige, ki je objavljena med pridatki, Goldberg ne navaja;⁴⁷³ Dizdar jo je uvrstil med pasove tipa Zvonimirovo LT 6, ki se pojavljajo v srednjelatenski noši na prostoru jugovzhodnih Alp in zahodne Panonije.⁴⁷⁴

Zvit meč in verigo je odkril tudi Pečnik v grobu 2/12 na Prelogah, ki ga je označil za latenskega.⁴⁷⁵ Vseboval je še pet suličnih osti, brusni kamen, več okroglih pasnih okovov in obročev, bronasto predrto pasno spono, ki je izgubljena, ter koščke ščitne grbe (verjetno tipa Mokronog-Arquà), ki so inventarizirani med pridatki groba 2/5 iz iste gomile,⁴⁷⁶ toda Pečnik jih tam ne omenja. V tej gomili je našel ščitno grbo še v grobu 2/45, skupaj z uhato sekuro in menda le eno sulično ostjo (inventarizirani sta dve). Te grobne celote so verjetno kontaminirane, možno je namreč, da so poznejši latenski pokopi poškodovali halštatske grobove.

4.1.4 NOŽI IN BRITVE

Nože in britve bi lahko le pogojno uvrstili med orožje, čeprav so spadali k opravam bojnikov. V magdalenskogorskih grobovih so zdaleč najpogostejši kratki noži s trnastim nastavkom, na katerega je bil nataknen lesen držaj, kar je vidno na bolj ohranjenih primerkih z ostanki ali odtisi lesa (*sl. 45 in sl. 53: 1–3*). Manjši delež predstavljajo dolgi noži s ploščatim nastavkom za držaj, ki je imel koščeno oblogo pritrjeno z železnimi zakovicami (*sl. 45 in sl. 53: 4, 5*). Dvodelni primerki na zaklep, sestavljeni iz železnega rezila in koščenih ali roževinastih platišč, ki ju drži skupaj bronast okov (*sl. 45 in sl. 53: 6, 7*), so skromno zastopani, po obliki pa spominjajo na britve.

Železni noži s trnastim nastavkom in dozdevno lesenim držajem so bili stalnica vse halštatsko obdobje.⁴⁷⁷ Verjetno so služili za pripomoček pri raznih opravilih, prototip zanje pa bi lahko videli v starejših bronastih izvedbah.⁴⁷⁸ Drugače je z velikimi noži s ploščatim na-

from Grave V/19–20, with three round hollows (for coral inlays?), is reminiscent of the Early La Tène examples from the Central European area.⁴⁷⁰ An Early La Tène sword in combination with a Negova helmet was recently found at Dürrnberg⁴⁷¹ and represents a good parallel for Grave V/29 at Lašček.

The tumuli of Magdalenska gora also revealed swords from the Late La Tène period. One of them, bent, was found in Tumulus V at Lašček, in Grave V/42 on the eastern edge, not deep beneath the surface. The grave supposedly contained a cremation burial, since there is no mention of bones. Apart from the sword, it further revealed a spearhead with a wide blade, a round shield boss, a knife with a loop as handle terminal and two fragments of a grey-brown vessel, which date the burial into the Mokronog IIIa phase.⁴⁷² The chain published among the goods is not mentioned by Goldberg.⁴⁷³ It was determined as part of a belt of the Zvonimirovo LT 6 type by Dizdar, which formed part of the Middle La Tène costume in the area of the south-eastern Alps and western Pannonia.⁴⁷⁴

A bent sword and a chain were also found by Pečnik in Grave 2/12 at Preloge, which he marked as La Tène.⁴⁷⁵ The grave further revealed five spearheads, a whetstone, several round belt fittings and rings, a bronze open-work belt clasp (now lost), as well as pieces of an umbo (probably of the Mokronog-Arquà type), all of which are inventoried among the goods of Grave 2/5 from the same tumulus,⁴⁷⁶ though Pečnik made no mention of them there. He found another umbo in Grave 2/45 of the same tumulus, together with a shaft-hole axe and reportedly a single spearhead (two are inventoried). These grave groups may be contaminated, since it is possible that later La Tène burials disturbed the Hallstatt graves.

4.1.4 KNIVES AND RAZORS

Knives and razors formed parts of the warrior outfit, but are treated as weapons with reservation. By far the

⁴⁷² Guštin 1984, 333; *id.* 1991, 58; Božič 1987, 876, T. 58: 1–4; *id.* 1999, 210.

⁴⁷³ Hencken 1978, 40, Fig. 163c. Koščki take verige so zabeleženi še med najdbami gomile V brez znane grobne celote: *ibid.*, Fig. 170g.

⁴⁷⁴ Dizdar 2009, 275 s, op. 7, karta 1, T. 3: 1.

⁴⁷⁵ Tecco Hvala/Dular/Kocuvan 2004, 33 ss, T. 21: 12.

⁴⁷⁶ Zakovice s polkrožno kapico, kakšna nastopa v grobu 2/5 s Prelog, se pojavljajo na omenjenemu tipu ščitnih grb (glej npr. Righi 2001, 117 s, Fig. 16: 61,62, 18: 69,70). Na to me je opozoril Dragan Božič, ki se mu za napotek zahvaljujem. Ščitne grbe tega tipa pa je definirjal in kartiral Guštin 1991, 57 s, sl. 30.

⁴⁷⁷ Prerez skozi čas ponazarjajo reprezentativni grobovi dolenjske halštatske skupnosti, glej npr. Dular J. 2003, sl. 59A: 3, 61A: 4, 66: 19, 68: 19, 78: 11, 80B: 20, 81: 2, 86: 5, 90: 15, 91: 9.

⁴⁷⁸ Stare F. 1954b, T. 46: 1; *id.* 1975, T. 7: 10; Križ 1995, Kat. št. 78; Šinkovec 1995, T. 35: 232–234; *ead.* 1996, 146.

⁴⁷⁰ Frey 1987, 18, Fig. 9; Haffner 1992, 48 ff, Abb. 20, 26, 40, 44, 54, Falttaf. 1,2; Egg/Hauschild/Schönfelder 2006, 182 ff, Tab. 1, Abb. 10.

⁴⁷¹ Moser 2009, 104 f, Abb. 3 (SK V), 4,5.

⁴⁷² Guštin 1984, 333; *id.* 1991, 58; Božič 1987, 876, T. 58: 1–4; *id.* 1999, 210.

⁴⁷³ Hencken 1978, 40, Fig. 163c. Fragments of such a chain are also recorded among the finds from Tumulus V without preserved grave context: *ibid.*, Fig. 170g.

⁴⁷⁴ Dizdar 2009, 275 f, n. 7, map 1, T. 3: 1.

⁴⁷⁵ Tecco Hvala/Dular/Kocuvan 2004, 33 ff, 127 ff, T. 21: 12.

⁴⁷⁶ Grave Group 2/5 from Preloge includes a rivet with a semicircular head. Such rivets appear on the above-mentioned umbo type (see, for example, Righi 2001, 117 f, Figs. 16: 61,62, 18: 69,70); I would like to thank Dragan Božič for this reference. The Mokronog-Arquà umbo type was defined and mapped by Guštin 1991, 57 f, Abb. 30.

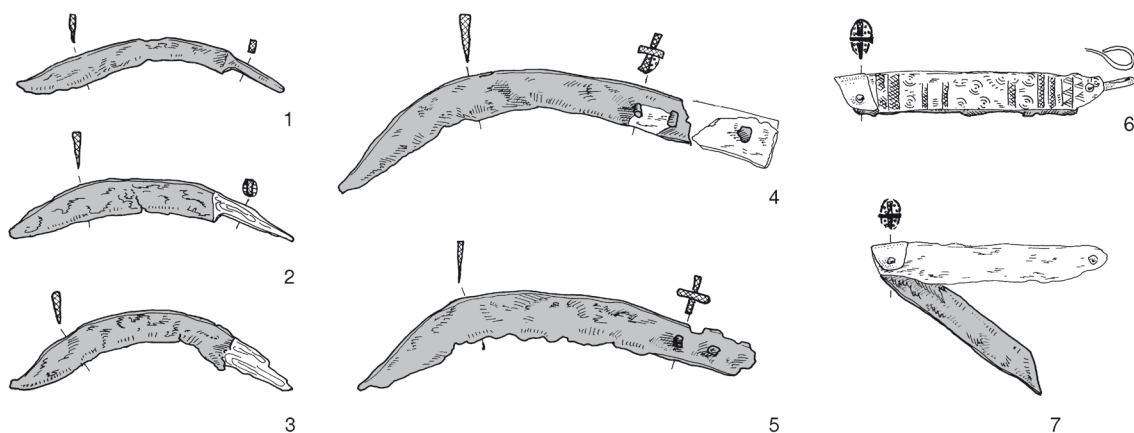

Sl. 53: Noži s trnastim ali ploščatim nastavkom za ročaj in britve z Magdalenske gore. M. = 1:4.

Fig. 53: Knives, with either a narrow or a flat tang, and razors from Magdalenska gora. Scale = 1:4.

1 – Preloge, gr. 2/17; 2, 4 – najdbi brez znane grobne celote v NMS / finds without preserved contexts kept in the NMS;

3 – Preloge, gr. 4/1; 5 – Laščik, gr. V/15; 6 – Preloge, gr. 2/47; 7 – Preloge, gr. 2/38.

stavkom in koščeno oblogo, pritrjeno z zakovicami, ki se pojavijo ob koncu certoške stopnje in se razmahnejo v negovskem času. Ti so se nemara uporabljali kot bojni noži po vzgladu iz zgodnjelatske kulturne sredine.⁴⁷⁹ Zasledimo jih na prostoru vzhodnih Alp in zahodne Panonije;⁴⁸⁰ na dolenskem teritoriju so pogosti na najdiščih z najmlajšim halštatskim gradivom, kot sta Valična vas⁴⁸¹ in Dolenjske Toplice,⁴⁸² ter v Vinici, ki v tistem času predstavlja svojske poteze japodske kulture.⁴⁸³ Pojavljajo se v kombinacijah s sekiro z enostranskimi plavutmi in/ali kopjem⁴⁸⁴ ali z uhato sekiro.⁴⁸⁵ Z Magdalenske gore je znanih tudi nekaj primerkov velikih bojnih nožev z obročastim zaključkom ali zanko na koncu držaja,⁴⁸⁶ ki so značilni za poznolatsko obdobje.⁴⁸⁷

Med pridatki magdalenskogorskih grobov zasledimo tudi osem primerkov t. i. britev; pet jih je zabeleženih v sklopu grobnih celot,⁴⁸⁸ za tri primerke iz prazgodovinske zbirke muzeja v Ljubljani pa njihova pripadnost grobovom ni dokumentirana, toda po vsej

most frequent knife type in the graves at Magdalenska gora is short carved knives with a tang that carried a wooden mount, as evidenced by the better preserved examples with the remains of wood or of its impression (figs. 45 and 53: 1–3). Less well represented are long knives with a flat tang, which had a bone mount attached with iron rivets (figs. 45 and 53: 4, 5). Least represented are the two-piece folding knives, composed of an iron blade and either bone or horn mounts and a bronze loop for attachment held together by a bronze rivet (figs. 45 and 53: 6, 7). These are similar to razors.

Iron knives with a tang and a wooden grip appear throughout the Hallstatt period.⁴⁷⁷ They probably served as multipurpose implements. Their prototype could be sought in earlier bronze knives.⁴⁷⁸ Contrary to these, the large knives with a flat tang and bone mount attached with rivets only appeared at the end of the Certosa and reached their peak in the Negova phase. These might have been used as battle knives following the examples from the Early La Tène cultural milieu.⁴⁷⁹ They were found in the eastern Alpine area and in western Panonia.⁴⁸⁰ In Dolenjska, they are frequent finds on the sites with the latest Hallstatt material, such as at Valična

⁴⁷⁹ Gabrovec 1987, 73.

⁴⁸⁰ Gabrovec 1966c, 189 s, T. 5: 4,5, 8: 3,4, 10: 9, 20: 3,4, 24: 6, 30: 3; Pauli 1978, 250, Abb. 35: 27; Teržan 1977, 14, sl. 3: 5; ead. 1990a, 118, op. 495, T. 83: 6.

⁴⁸¹ Teržan 1973, 685.

⁴⁸² Ead. 1976, 387.

⁴⁸³ Gabrovec 1966c, 190 s, T. 20: 3.

⁴⁸⁴ *Dolenjske Toplice*, gr. V/2, V/6, V/14, VII/11; Teržan 1976, T. 22: 8, 27: 14, 28: 2, 47: 8; *Novo mesto-Kapiteljska njiva*, gr. 2/1, 2/29; Križ 1997, T. 1: 5, 21: 3; *Magdalenska gora-Preloge*, gr. 2/69, X/64.

⁴⁸⁵ *Magdalenska gora-Preloge*, gr. 13/60.

⁴⁸⁶ Hencken 1978, Fig. 164a, 170i; Tecco Hvala/Dular/Kocuvan 2004, T. 38B: 2.

⁴⁸⁷ Božič 1987, 874 ss, sl. 43: 5, 44: 6,7, 46: 7; id. 1993, 143.

⁴⁸⁸ *Laščik*, gr. V/12; *Preloge*, gr. VIII/8, 2/38, 2/47, 2/69.

⁴⁷⁷ Their long use is indicated by the representative graves of the Dolenjska Hallstatt community: see, for example, Dular J. 2003, Abb. 59A: 3, 61A: 4, 66: 19, 68: 19, 78: 11, 80B: 20, 81: 2, 86: 5, 90: 15, 91: 9.

⁴⁷⁸ Stare F. 1954b, T. 46: 1; *id.* 1975, T. 7: 10; Križ 1995, Cat. No. 78; Šinkovec 1995, T. 35: 232-234; ead. 1996, 146.

⁴⁷⁹ Gabrovec 1987, 73.

⁴⁸⁰ Gabrovec 1966c, 189 f, T. 5: 4,5, 8: 3,4, 10: 9, 20: 3,4, 24: 6, 30: 3; Pauli 1978, 250, Abb. 35: 27; Teržan 1977, 14, Fig. 3: 5; ead. 1990a, 118, n. 495, T. 83: 6.

verjetnosti izvirajo s Pečnikovih izkopavanj gomile 2 na Prelogah.⁴⁸⁹ Njihovo uporabo v certoški in negovski stopnji izpričujejo moška pokopa 2/38 z dvogrebenasto čelado in 2/69 s sekuro z enostranskimi plavutmi. V zgodnjo negovsko stopnjo lahko uvrstimo tudi grob 1/20 z Znančevih njiv v Novem mestu, ki je vseboval tak zaklepni nož oz. britev.⁴⁹⁰ Vzorednice zanje pa najdemo v Hallstattu.⁴⁹¹

Z orožjem so povezana vprašanja vojaške organizacije in taktike.⁴⁹² Frey je v prispevku o halštatski oborožitvi v jugovzhodnoalpskem svetu – opirajoč se v glavnem na pripovedništvo situlske umetnosti – izpostavil razliko med motivi na situlah v Padski nižini ter na pasni sponi z Vač. Upodobitve na situlah iz Bologne (Providence, Certosa in Arnoaldi) je interpretiral kot nekakšne urejene vojaške formacije, sestavljene iz pehotnih enot s konjenico na čelu, ki naj ne bi predstavljale tako trdne organizacije kot so bile hoplitske falange grškega ali etruščanskega tipa. Na pasni sponi z Vač, ki prikazuje dvoboj konjenikov s kopji v navzočnosti dveh težko oboroženih pešakov, pa je prepoznal drugačen način bojevanja, za katerega je menil, da je morebiti povezan s skitskimi vplivi ali pa z idealom tedanjega aristokratskega življenja.⁴⁹³

Te tematike se je lotila tudi Teržanova in pokazala, da organizirana vojaška formacija ni bila značilna zgolj za etruščansko Felsino, temveč za ves severnojadranski prostor.⁴⁹⁴ Odraža pa se v hierarhiji vojaških oprav, ki jo nakazujejo grobovi z orožjem, in v heroizaciji, ki jo je moč slutiti v situlskem pripovedništvu. V študiji halštatske družbene strukture je podrobneje ovrednotila sestave z orožjem iz Podzemlja, Vač, Stične, Dolenjskih Toplic in Magdalenske gore (Mecklenburška zbirka).⁴⁹⁵ Pokazala je, da je v moških opravah iz zgodnjega halštatskega obdobja moč prepoznati le dva sloja (bojevniki in nebojevniki, ki je bil številnejši), da so se znotraj bojevnikega sloja v stopnji Stična pričele uveljavljati razlike, ki so izražene v štirih vrstah oprav. Razen tega ugotavlja porast pokopov z orožjem v mlajšem halštatskem obdobju, ki jih je po opravah razdelila v pet skupin; ob tem je opozorila tudi na razlike med posameznimi najdišči. V razpravah o Stični je strukturo moških pokopov v tamkajšnjih gomilah še podrobneje preučila in jih osvetlila z različnih vidikov.⁴⁹⁶

⁴⁸⁹ Hencken 1978, Fig. 120i, 282b,c; Tecco Hvala/Dular/Kocuvan 2004, T. 36: 18, 45: 13, 58B: 3, 157: 5-7.

⁴⁹⁰ Knez 1986, T. 4: 2.

⁴⁹¹ Kromer 1959b, T. 31: 8, 32: 21, 87: 4,5, 206: 5; Hodson 1990, Pl. 11: 4.

⁴⁹² Snodgrass 1967; Frey 1973; Stary 1981.

⁴⁹³ Frey 1973, 621 ss.

⁴⁹⁴ Teržan 1997.

⁴⁹⁵ Ead. 1985, 77 ss.

⁴⁹⁶ Ead. 2008, 238 ss.

vas,⁴⁸¹ Dolenjske Toplice⁴⁸² and Vinica, which shows characteristic features of the Iapodic culture in that period.⁴⁸³ They appear in combination with a one-sided winged axe and/or a javelin⁴⁸⁴ or a shaft-hole axe.⁴⁸⁵ At Magdalenska gora, several examples of large battle knives with a ring or loop terminal were found,⁴⁸⁶ which are characteristic of the Late La Tène period.⁴⁸⁷

The grave goods from Magdalenska gora also include eight examples of so-called razors. Five of them come with a known grave provenance.⁴⁸⁸ This is not the case for the other three examples kept in the prehistoric collection of the museum in Ljubljana, though they were most likely excavated by Pečnik in Tumulus 2 at Preloge.⁴⁸⁹ Their use in the Certosa and Negova phases is revealed by male Grave 2/38, with a double-crested helmet, and Grave 2/69, with a one-sided winged axe. The Early Negova phase is also the date for Grave 1/20 at Znančeve njive in Novo mesto, which contained a folding knife or razor.⁴⁹⁰ Parallels for them can be found at Hallstatt.⁴⁹¹

Finds of weapons inevitably bring about questions as to the military organisation and tactics.⁴⁹² Frey studied the Hallstatt armament in the south-eastern Alpine world, primarily on the basis of the situla art depictions. He observed a difference between the scenes on the situlae from the Po Valley and the scene on the belt clasp from Vače. He interpreted the scenes on the situlae from Bologna (Providence, Certosa and Arnoaldi) as a sort of an orderly battle formation, composed of infantry units with cavalry at the forefront, which would not represent as tightly organised units as the hoplite phalanges of the Greek or the Etruscan type. The belt clasp from Vače, on the other hand, shows a confrontation of two javelin-bearing horsemen in the presence of a pair of heavily armed foot soldiers, in which Frey identified a different manner of combat,

⁴⁸¹ Teržan 1973, 685.

⁴⁸² Ead. 1976, 387.

⁴⁸³ Gabrovec 1966c, 190 f, T. 20: 3.

⁴⁸⁴ *Dolenjske Toplice*, Gr. 5/2, 5/6, 5/14, 7/11; Teržan 1976, T. 22: 8, 27: 14, 28: 2, 47: 8; *Novo mesto-Kapiteljska njiva*, Gr. 2/1, 2/29; Križ 1997, T. 1: 5, 21: 3; *Magdalenska gora-Preloge*, Gr. 2/69, X/64.

⁴⁸⁵ *Magdalenska gora-Preloge*, Gr. 13/60.

⁴⁸⁶ Hencken 1978, Figs. 164a, 170i; Tecco Hvala/Dular/Kocuvan 2004, T. 38B: 2.

⁴⁸⁷ Božič 1987, 874 ff, Figs. 43: 5, 44: 6,7, 46: 7; *id.* 1993, 143.

⁴⁸⁸ *Laščik*, Gr. V/12; *Preloge*, Gr. VIII/8, 2/38, 2/47, 2/69.

⁴⁸⁹ Hencken 1978, Figs. 120i, 282b,c; Tecco Hvala/Dular/Kocuvan 2004, T. 36: 18, 45: 13, 58B: 3, 157: 5-7.

⁴⁹⁰ Knez 1986, T. 4: 2.

⁴⁹¹ Kromer 1959b, T. 31: 8, 32: 21, 87: 4,5, 206: 5; Hodson 1990, Pl. 11: 4.

⁴⁹² Snodgrass 1967; Frey 1973; Stary 1981.

12/1



IV/3

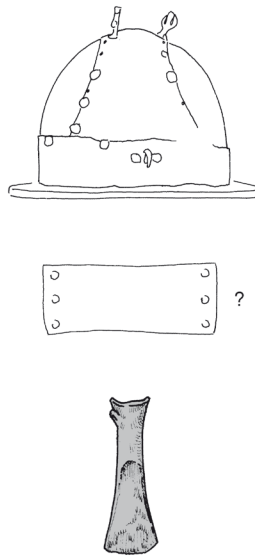

13/10

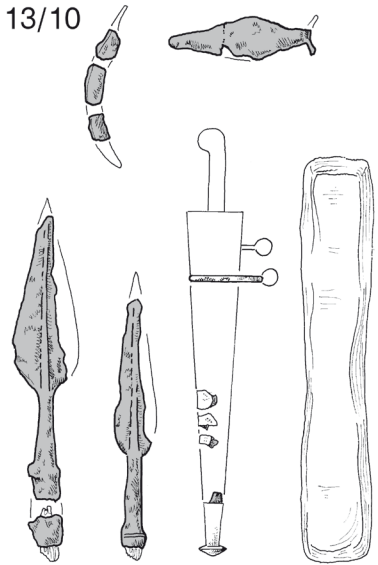

2/57

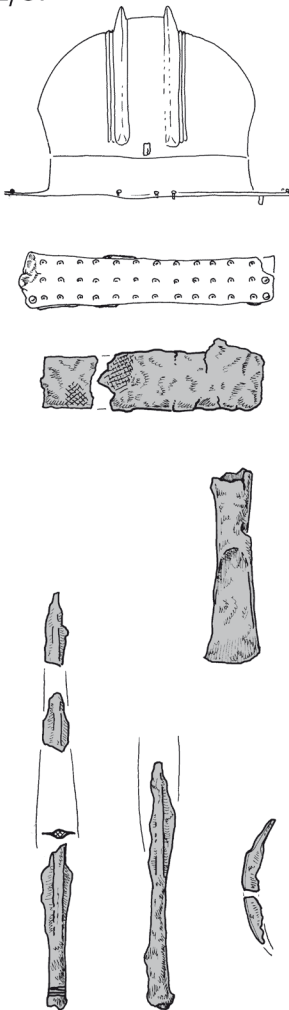

2/13

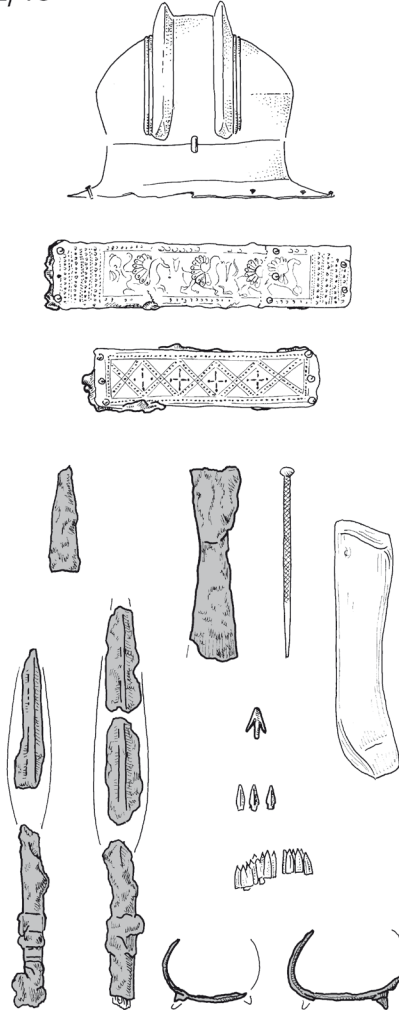

V/29

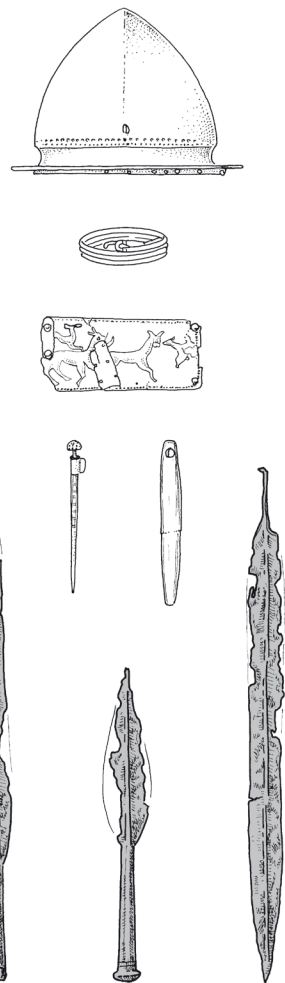

Sl. 54: Reprezentativne bojne oprave z Magdalenske gore.
 Fig. 54: Representative warrior outfit from Magdalenska gora.

V tem prikazu dopolnjujem sliko magdalenskogorskih vojaških pokopov z grobnimi celotami iz dunajskega in ljubljanskega muzeja (sl. 45: B), ki niso bile vključene v njeno analizo. Prvi pojav orožja lahko na Magdalenski gori zaznamo v stopnji Podzemelj 2, in sicer v grobu 12/1 z Laščika, ki bi mu hipotetično lahko pripisali tudi stožčasto čelado (sl. 54: *levo zgoraj*). Drugod na Dolenjskem je elita v tistem času nosila skledaste čelade v kombinaciji s plavutasto in križno sekuro, kratkim ukrivljenim železnim mečem (t. i. *mahaira*) ter običajno z eno sulico in bolj redko s puščicami. Konjska oprema v nekaterih od teh sestavov pa priča, da so bili med njimi konjeniki.⁴⁹⁷ Toda večina mož ni bila oborožena, zato o kakih vojaških enotah takrat verjetno še ni mogoče govoriti. Orožje je pomenilo predvsem prestiž in statusni simbol, saj so ga posedovali le redki izbranci, ki tako kažejo na uveljavljanje novih družbenih idealov in na razslojevanje.⁴⁹⁸

V stopnji Stična zasledimo na Magdalenski gori dve ali tri oprave s sestavljeno čelado in tulasto sekuro (sl. 54: v *sredini zgoraj*),⁴⁹⁹ morda bi v ta čas lahko datirali tudi železno tulasto sekuro, okrašeno z bronastimi rombičnimi aplikami (sl. 46: 13). V dolenjski halštatski sredini se takrat pojavijo posamezne prvine težke obrambne oborožitve, kot so ščiti in oklepi (v Stični,⁵⁰⁰ Novem mestu⁵⁰¹ in morda na Velikem Vinjem vrhu oz. Šmarjeti).⁵⁰² Oklep iz Stične (gom. 52), ki je bil ponovno restavriran, tehta 2,62 kg; za izdelavo je bila torej potrebna znatna količina brona ter precejšen vložek dela torej. Ob restavriranju so ugotovili, da na njem ni sledov pogoste nošnje in da zelo verjetno nikoli ni bil uporabljen v boju.⁵⁰³ Težki so morali biti tudi ščiti, od katerih so se ohranile le železne ščitne grbe pravokotne oblike. Domnevno so bili leseni in so imeli ovalno obliko.⁵⁰⁴ V teh opravah zasledimo še čelade, izdelane po vzhodnosredozemskem ali italiskem vzoru (koničasta, sestavljena), ter sulico ali dve, pa tudi puščice in celo

⁴⁹⁷ Škoberne 1999, 92 ss, sl. 58, 67–72.

⁴⁹⁸ Teržan 1985, 80, 84, sl. 1, 2, 5, 7.

⁴⁹⁹ *Laščik, gr. 4/1; Preloge, gr. IV/3*. Glej tu poglavje 4.2 o čeladah.

⁵⁰⁰ *Gom. 40(41 ali 43)/grob z oklepom, gom. 52/grob z oklepom, gom. 125/centralni grob s ščitno grbo*: Gabrovec et al. 2006, T. 135, 201: 18, 207, z navedbo starejše literature. Morda bi ščitno grbo lahko prepoznali tudi v ploščici (15 x 30 cm) iz bronaste pločevine z ostanki železne podloge in lesa iz groba VI(=55)/26, ki je imel menda centralno lego in kamnito konstrukcijo: Wells 1981, 79, Fig. 158b. Ta ploščica je prevelika za pasno spono in po dimenzijah ustreza ščitni grbi iz centralnega groba v gomili 125.

⁵⁰¹ *Znančeve njive, grob z oklepom in ščitno grbo*: Gabrovec 1960b, 29 ss, sl. 5–7; *Kapiteljska njiva, gr. 3/22 s ščitno grbo*: Križ 1997, 28 ss, 68, T. 50.

⁵⁰² *Mlade vine, gom. II/1879*: Dular A. 1991, T. 22: 1 (železna plošča, ki ima robove okovane z bronasto pločevino, je verjetno del ščitne grbe).

⁵⁰³ Born 2008, 155 s.

⁵⁰⁴ Gabrovec 1960b, 46; Križ 1997, 28 ss.

possibly tied either to Scythian influence or to the ideal of aristocratic life of the time.⁴⁹³

The topic was also examined by Teržan, who showed that organized battle formation was not a characteristic exclusive to Etruscan Felsina, but was present across the northern Adriatic area.⁴⁹⁴ This formation is reflected in the hierarchy of the warrior outfit as revealed by the graves with weapons, and in glorification of heroes perceived in the narratives of the situla art. In her study of the social structure in the Hallstatt period, Teržan took a closer look at the grave groups with weapons from Podzemelj, Vače, Stična, Dolenjske Toplice and Magdalenska gora (Mecklenburg Collection).⁴⁹⁵ She observed that the warrior outfit from the Early Hallstatt period revealed two classes (warrior and non-warrior, the latter being more numerous) and that within the warrior class differences began appearing during the Stična phase, as reflected in four outfit types. She also observed an increase in the number of burials with weapons in the Late Hallstatt period, which she divided into five groups on the basis of the outfit; whereby differences existed among individual sites. For the tumuli of Stična, she analysed the structure of male burials in them in even greater detail and from different aspects.⁴⁹⁶

Her analysis of the warrior burials at Magdalenska gora is supplemented here with the grave groups from the museums in Ljubljana and Vienna (fig. 45: B). Weapons first began appearing in graves in the Podzemelj 2 phase. This is indicated by Grave 12/1 at Laščik, to which a conical helmet might also be ascribed (fig. 54: *top left*). Elsewhere in Dolenjska, the elite of the period wore bowl-shaped helmets in combination with a winged and a lugged axe, a short sword with a curved blade (so-called *machaira*) and usually one spear, rarely with arrows. Horse gear found in some of these graves reveals the existence of horsemen.⁴⁹⁷ Nevertheless, most of the men were not armed. For that reason, we can as yet not talk of the existence of military units in this early period. Weapons primarily represented an object of prestige and a status symbol, possessed only by the select few, which points to the introduction of new social ideals and to stratification.⁴⁹⁸

The warrior outfit in two or three graves at Magdalenska gora, dated to the Stična phase, includes a composite helmet and a socketed axe (fig. 54: *top centre*),⁴⁹⁹ while the same date could be ascribed to the iron socketed axe decorated with bronze rhombic appliqués (fig. 46: 13). In this period, the first elements of

⁴⁹³ Frey 1973, 621 ff.

⁴⁹⁴ Teržan 1997.

⁴⁹⁵ *Ead.* 1985, 77 ff.

⁴⁹⁶ *Ead.* 2008, 238 ff.

⁴⁹⁷ Škoberne 1999, 92 ff, Figs. 58, 67–72.

⁴⁹⁸ Teržan 1985, 80, 84, Abb. 1, 2, 5, 7.

⁴⁹⁹ *Laščik, Gr. 4/1; Preloge, Gr. IV/3*. See here Chapter 4.2 on helmets.

bronast meč,⁵⁰⁵ ki je na splošno težji od železnega in se ga ne da tako dobro naostri.⁵⁰⁶ Pri tem velja opozoriti, da sekire v opravah te vrste praviloma ne nastopajo; tudi v primeru pokopa kleinklenškega veljaka z oklepom v gomili Kröll-Schmiedkogel se ne ve natanko, kje so ležale tri tulaste sekire, šest suličnih osti in dvogrebenasta čelada.⁵⁰⁷ Na Magdalenski gori težkega obrambnega orožja niso našli, je pa prikazano na fragmentu sestavljene čelade s prizorom korakajočih vojščakov, ki so opremljeni z okroglim ščitom, veliko sulico in skledasto čelado (Laščik, gr. 4/1).⁵⁰⁸ Na teritoriju dolenske skupnosti hoplitsko opravo (okrogel ščit in čelada s perjanico) ponazarja še obesek v obliki vojščaka, ki je bil najden v naselbini na Kučarju pri Podzemlju⁵⁰⁹ in ima najboljšo primerjavo v liburnijskem prostoru.⁵¹⁰ Razne upodobitve okroglih in ovalnih ščitov pa so znane predvsem z italskega polotoka.⁵¹¹ Na prehodu iz starejšega v mlajše halštatsko obdobje lahko na Magdalenski gori zaznamo pojav bodala in širokolistne sulične osti (*sl. 54: gr. 13/10*), ki spominjata na oborožitev picenskega kroga.

V mlajšem halštatskem obdobju (Ha D) je na Dolenjskem opazno povečanje števila oboroženih pripadnikov in večja uniformnost oprav (dvogrebenaste čelade, tulaste sekire, sulične osti, zraven so običajno sodile še pravokotne pasne spona). O kovinskih oklepih in ščitnih grbah ni sledi, prav tako ni mečev, vsaj v kačasti in certoški stopnji ne. Razlike med bojevniki so vidne predvsem v boljši ali slabši opremljenosti in v insignijah,⁵¹² ki tako nakazujejo obrise nekakšne vojaške hierarhije. Najbolje so bili oboroženi konjeniki, med katerimi lahko iščemo poveljnike na čelu posameznih rodov, ki so nosili čelade in žezla (*sl. 54: gr. 2/57, 2/13 in sl. 55*). Nižji rang so zavzemale pehotne enote, ki so jih sestavljali vojščaki, oboroženi s sekiro in z eno ali dvema sulicama, ter drugi, ki so bili opremljeni najsi bo le s sekirami ali samo s sulicami (*sl. 45*). Lokostrelci so maloštevilni, zasledimo jih tako med elito kot tudi med pripadniki nižjega ranga. Prikaz domnevnih vojaških enot na *sl. 55* temelji na magdalenskogorskih grobnih sestavih z orožjem iz kačaste in certoške stopnje. Enako vojaško hierarhijo razkrivajo tudi oprave z drugih najdišč.⁵¹³

Ob koncu halštatskega obdobja je v oborožitvi vnovič prišlo do sprememb, kar bi lahko pripisali širjenju

⁵⁰⁵ Gabrovec 1960b; Teržan 2008, 268, 282 ss, 300 ss, sl. 31, 50.

⁵⁰⁶ Snodgrass 1967, 36; Egg 2004b, 43.

⁵⁰⁷ Egg/Kramer 2005, 14, 33 s, Abb. 27.

⁵⁰⁸ Kromer/Gabrovec 1962, Y 42; Gabrovec 1964–1965b; Frey 1969, T. 58; id. 1973, Abb. 2: 2; Egg 1980; Tecco Hvala/Dular/Kocuvan 2004, sl. 15, T. 1: 1; Turk 2005, sl. 17, 66, 67.

⁵⁰⁹ Dular J. 1978, T. 41: 1.

⁵¹⁰ Batović 1955, 234 ss, sl. 1, T. 1: 7,8; id. 1987, 360, 376ss, sl. 21: 6, T. 40: 4; Teßmann 2001, 82 ss, Abb. 52, 58: 16–18.

⁵¹¹ Stary 1981, T. 1–70.

⁵¹² Teržan 1985, 95, sl. 17.

⁵¹³ Ibid., sl. 1, 5, 6.

heavy armour, such as shields and cuirasses, appear in the Dolenjska Hallstatt milieu (at Stična,⁵⁰⁰ Novo mesto⁵⁰¹ and possibly Veliki Vinji vrh (Šmarjeta).⁵⁰² Speaking of weight, the restored cuirass from Stična (Tum. 52), for example, weighs 2.62kg and shows that a great amount of bronze as well as tinsmith's time and effort was needed to make it. It was observed during restoration that the cuirass did not show marks of frequent wear and that it was very likely never used in battle.⁵⁰³ The shields must also have been heavy. Of them, only the rectangular bosses are preserved, while the rest was presumably made of wood and oval in shape.⁵⁰⁴ The warrior outfit further includes a helmet, made from eastern Mediterranean or Italic models (ogival, composite helmets), as well as a spear or two and arrows, even a bronze sword,⁵⁰⁵ generally heavier than an iron one and not as easily sharpened.⁵⁰⁶ It has to be noted that axes usually do not form part of this type of outfit; even for the burial of a dignitary with cuirass from Kleinklein, the Kröll-Schmiedkogel tumulus, the position of the three socketed axes, six spearheads and a double-crested helmet is not clear.⁵⁰⁷ The graves at Magdalenska gora revealed no finds of heavy armour. The latter is, however, shown on a fragment of a composite helmet with a scene of marching soldiers equipped with a round shield, large spear and bowl-shaped helmet (Laščik, Gr. 4/1).⁵⁰⁸ In the territory of the Dolenjska community, the hoplite outfit (round shield and crested helmet) is discernible on a soldier-shaped pendant found in the settlement at Kučar near Podzemelj.⁵⁰⁹ Its best analogy comes from the Liburnian area.⁵¹⁰ Having said that, various depictions of round and oval shields are known

⁵⁰⁰ Tum. 40(41 or 43)/Grave with cuirass, Tum. 52/Grave with cuirass, Tum. 125/Central grave with shield boss: Gabrovec et al. 2006, T. 135, 201: 18, 207, with references. The bronze plate (15 x 30cm) with iron and wooden remains from Grave VI(=55)/26, which reportedly had a central position and stone construction (Wells 1981, 79, Fig. 158b), could be identified as a shield boss. The plate is too big for a belt clasp. In size, it is similar to the shield boss from the central grave in Tumulus 125.

⁵⁰¹ Znančeve njive, Grave with cuirass and shield boss: Gabrovec 1960b, 29 ff, Abb. 5–7; Kapiteljska njiva, Gr. 3/22 with shield boss: Križ 1997, 28 ff, 68, T. 50.

⁵⁰² Mlade vine, Tum. II/1879: Dular A. 1991, T. 22: 1 (The fragmented iron plate bordered with a bronze band is probably part of a shield boss).

⁵⁰³ Born 2008, 155 f.

⁵⁰⁴ Gabrovec 1960b, 46; Križ 1997, 28 ff.

⁵⁰⁵ Gabrovec 1960b; Teržan 2008, 268, 282 ff, 300 ff, Abb. 31, 50.

⁵⁰⁶ Snodgrass 1967, 36; Egg 2004b, 43.

⁵⁰⁷ Egg/Kramer 2005, 14, 33 f, Abb. 27.

⁵⁰⁸ Kromer/Gabrovec 1962, Y 42; Gabrovec 1964–1965b; Frey 1969, T. 58; id. 1973, Abb. 2: 2; Egg 1980; Tecco Hvala/Dular/Kocuvan 2004, Abb. 15, T. 1: 1; Turk 2005, Figs. 17, 66, 67.

⁵⁰⁹ Dular J. 1978, T. 41: 1.

⁵¹⁰ Batović 1955, 234 ff, Abb. 1, T. 1: 7,8; id. 1987, 360, 376 ff, Fig. 21: 6, T. 40: 4; Teßmann 2001, 82 ff, Abb. 52, 58: 16–18.

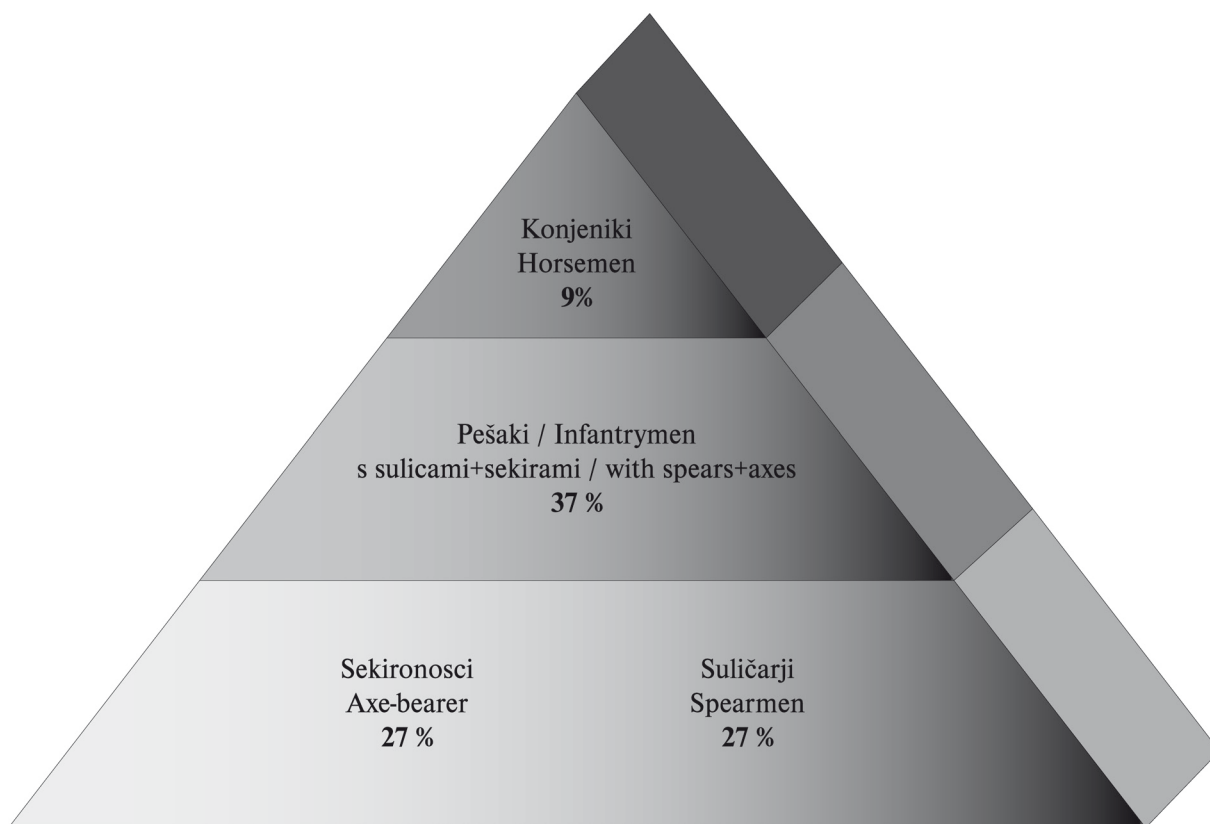

Sl. 55: Vojaška formacija in hierarhija na Magdalenski gori.
Fig. 55: Military formation and hierarchy at Magdalenska gora.

latenskih vplivov. Z meči, kopji in bojnimi noži se je deloma spremenil tudi način bojevanja. Ob teh novostih je še vedno prevladovala tradicionalna tehnika boja s sekuro, le da so te spremenile obliko – pojavile so se sekire z enostranskimi plavutmi in uhate. Razen tega so zamenjali tudi čelade, po italjskih vzorih so pričeli nositi negovski tip. Ponekod je bila takrat oborožena že skoraj tretjina prebivalcev, vendar v poslednji fazi halštatske kulture na Dolenjskem med njimi ni več opaziti bogatih vojaških pokopov in konjenikov, po drugi strani pa je čutiti splošno obubožanje, kar se odraža v večjem številu grobov brez pridatkov ali samo s keramiko.⁵¹⁴

Nazadnje ostaja še vprašanje, čemu je orožje sploh služilo. V raznih razpravah je bilo pokazano, da se ni uporabljalo zgolj za vojaške namene, temveč tudi pri lovu in žrtvovanju. Na simbolni ravni si vlogo orožja v grobnem kultu lahko razlagamo kot izkazovanje moči, dominacije, družbenega statusa oz. kot apoteozo ali heroizacijo.⁵¹⁵

⁵¹⁴ To problematiko obravnavam v poglavju 3.3 o grobnih pridatkih, sl. 39 in 44. Glej še Teržan 1976, 393; ead. 1985, 92 s, 95, sl. 17.

⁵¹⁵ Eibner 1981; ead. 2004, 630 s; ead. 2009; Kull 1997, 260 ss; Teržan 1997, 655; Egg/Kramer 2005, 15 s, 29, Abb. 23, 24, Lücke 2007, 598 ss; Egg/Lehnert 2011, 243 s.

primarily in the Apennine Peninsula.⁵¹¹ A reminiscence of the armament in the Picenum area could also be seen in daggers and broad-bladed spearheads, such as were found at Magdalenska gora and dated to the transition from the Early to Late Hallstatt period (fig. 54: Gr. 13/10).

The Late Hallstatt period (Ha D) in Dolenjska witnessed a noticeable increase in the number of armed individuals as well as an increased uniformity of the outfit (double-crested helmet, socketed axe, spearhead, usually also rectangular belt clasp). There are no traces of metal cuirasses and shield bosses, or of swords, at least not in the Serpentine and Certosa Fibulae phases. Differences among warriors are visible primarily in either good or poor equipment and in insignia,⁵¹² which thus point to a sort of a military hierarchy. Best equipped were horsemen, which probably included commanders, who might also have been heads of clans and wore helmets and maces (fig. 54: Gr. 2/57, 2/13 and fig. 55). Lower in rank were infantry units composed of soldiers armed with an axe and one or two spearheads and other soldiers armed with only an axe or a spear (fig. 45). Archers were few and could be detected among the elite as well as in the lower ranks. The scheme of the supposed military

⁵¹¹ Stary 1981, T. 1–70.

⁵¹² Teržan 1985, 95, Abb. 17.

Ob tem je imelo orožje zagotovo tudi povsem praktično vlogo v bitkah za zagotavljanje preživetja teh skupnosti (kot npr. prisvajanje in varovanje naravnih resursov, pridelkov in drugih dobrin, nadzor nad trgovanjem in za zaščito pred plenjenjem ipd.). Močnejše oboroževanje na Dolenjskem sovпада prav s časom, ko so na naselbinah potekala obnovitvena dela in ponovna utrjevanja obzidij (marsikje na pogoriščih), ko so v zaledju zrasla nova naselja in so pokrajine na severovzhodu domala opustele, kar se pripisuje vpadom konjeniških in lokostrelskih ljudstev oz. skitski nevarnosti.⁵¹⁶ Morebiti je prav ta grožnja prispevala k formiranju nekakšne enotne teritorialne vojaške sile v skupno obrambo pred zunanjimi sovražniki.⁵¹⁷ Ekspanzionističnih pretenzij dolenjski skupnosti verjetno ne gre pripisati, saj ni nobenih znakov, da bi se razširila onkraj teritorija, ki ga je zavzemala v fazi nastanka. Ni pa mogoče povsem izključiti notranjega rivalstva in teženj po hegemoniji med takratnimi središči kot tudi med posameznimi družinami v okviru ene srenje, kar bi lahko sklepali po nihanjih njihove moči in bogastva.⁵¹⁸ V tistem času si je Magdalenska gora pridobila pomembno mesto, saj je po oborožitvi spadala v sam vrh, kar priča tako število pokopov z orožjem kot tudi količinska zastopanost npr. sekir,⁵¹⁹ čelad,⁵²⁰ konj⁵²¹ itd. Znotraj te skupnosti je izstopala družina, ki je svoje umrle pokopavala v gomili 2 na Prelogah.⁵²²

Spremembe v negovski stopnji je prav tako moč razumeti v kontekstu širših dogajanj in spremenjene konjunktore, ko so se v srednjeevropskem prostoru uveljavili novi centri moči, in kulturnih pobud in s tem povezano širjenje latenske kulture. Dolenjska skupnost za ta dogajanja ni bila imuna.⁵²³ Njena vojaška moč se je skoncentrirala na naseljih blizu zahodne meje tega teritorija (Vače, Magdalenska gora, Stična, Valična vas, Dolenjske Toplice in Novo mesto), nekatera so v tem času šele dodobra zaživela (Valična vas, Dolenjske Toplice).⁵²⁴ Tudi takrat je Magdalenska gora predstavljala pomembno središče, kjer so nemara izdelovali uhate sekire in drugo orožje. Najvišji položaj v vojaški hierarhiji si je tedaj pridobila družina, katere člani so bili pokopani v gomili V na Laščiku. Trije so nosili negovske čelade, trije so bili oboroženi z latenskimi meči, ki predstavljajo za zdaj edine importe na Dolenjskem z matičnega območja latenske kulture v stopnji

⁵¹⁶ Teržan 1990a, 120, sl. 26; ead. 1998, 526 ss; ead. 2008, 308, 319; Dular/Tecco Hvala 2007, 143 ss, 252, sl. 82.

⁵¹⁷ Teržan 2008, 319 s.

⁵¹⁸ Dular/Tecco Hvala 2007, 247 ss, sl. 138–144; Teržan 2008, sl. 36, 37.

⁵¹⁹ Glej tu sl. 47.

⁵²⁰ Teržan 1976, 391; ead. 2008, sezname k sl. 55, 57, 59, 61.

⁵²¹ Dular J. 2007b, 737 ss, Abb. 1.

⁵²² Tecco/Hvala/Dular/Kocuvan 2004, sl. 52.

⁵²³ Dular/Tecco Hvala 2007, 252.

⁵²⁴ Teržan 1973, 679 ss; ead. 1976, 391 s; ead. 2008, 322.

organisation on *fig. 55* is based on the grave groups from Magdalenska gora with weapons from the Serpentine and Certosa Fibulae phases. The same military hierarchy is discernible in the outfit of other sites.⁵¹³

Changes in the armament again occurred at the end of the Hallstatt period, which could be attributed to La Tène influences. Swords, javelins and battle knives also brought about some changes in the way battles were waged. However, the traditional use of the axe was still the dominant fighting technique, the weapon only changed in form – one-sided winged and shaft-hole axes now appeared. The helmets were also of other types – the Negova type modelled on Italic types began to be used. At certain sites, almost a third of the population was armed, though the last phase of the Hallstatt culture in Dolenjska revealed no rich military burials and no horsemen burials. In fact, a general pauperisation is observable, which is reflected in an increased number of graves without goods and graves with pottery only.⁵¹⁴

The last remaining question concerns the actual use of the weapons found in graves. Various discussions on the topic have shown that they did not serve military purposes only, but were also used in hunting and animal sacrifice. On a symbolic level, the weapons in funerary cult may be interpreted as a manifestation of power, domination, social status or as a sign of apotheosis or glorification of heroes.⁵¹⁵

Apart from the above, weapons certainly had a very practical role in battles for ensuring the survival of these communities (such as appropriation and protection of natural resources, crops and other goods, control of trading, protection against plundering and others). Increased armament in Dolenjska coincides with renovations in settlements that included reinforcements of defensive walls (at many sites on burnt-down remains), but also with new settlements growing up in the hinterland, while the north-eastern regions became almost desolate, which has been attributed to the incursions of rider-archery peoples or the Scythian danger.⁵¹⁶ It might have been this threat that contributed to the formation of a sort of a unified territorial military force in a common defence against the external enemy.⁵¹⁷ It is less likely that the Dolenjska community had expansionist pretensions, since there are no signs of the community spreading beyond the territory occupied during the formative phase. It is, on the other hand, not possible to rule out internal strife

⁵¹³ *Ibid.*, Abb. 1, 5, 6.

⁵¹⁴ This topic is discussed in Chapter 3.3 on grave goods, *figs. 39, 44*. See also Teržan 1976, 393; ead. 1985, 92 f, 95, Abb. 17.

⁵¹⁵ Eibner 1981; ead. 2004, 630 f; ead. 2009; Kull 1997, 260 ff; Teržan 1997, 655; Egg/Kramer 2005, 15 f, 29, Abb. 23, 24, Lücke 2007, 598 ff; Egg/Lehnert 2011, 243 f.

⁵¹⁶ Teržan 1990a, 120, Fig. 26; ead. 1998, 526 ff; ead. 2008, 308, 319; Dular/Tecco Hvala 2007, 143 ff, 252, Fig. 82.

⁵¹⁷ Teržan 2008, 319 f.

Lt A. Iz nadaljnega poteka dogodkov pa je nazadnje razvidno, da se sekira očitno ni mogla kosati v boju z dolgim mečem.

4.2 ČELADE

Svojevrstni izraz moči in družbeno-kulturne identitete predstavljajo čelade, ki so zaradi tega cenjene tudi pri zbirateljih starin. Primerke z območja današnje Slovenije je prvi ovrednotil Gabrovec in opredelil njihovo kronološko sosledje.⁵²⁵ Po njih je poimenoval faze mladohalštatskega obdobja na Dolenjskem;⁵²⁶ stopnja negovskih čelad se je v kronološki shemi dolenjske halštatske skupnosti obdržala vse do danes.⁵²⁷ Magdalenskogorske čelade so vključene še v razne druge študije,⁵²⁸ zato želim na tem mestu opozoriti predvsem na pogrešane primerke ter na tiste grobne sestave (sl. 56 in sl. 57), kjer so opazna neskladja med stanjem v muzejskih zbirkah in zabeležkami izkopavalcev.

Na tem najdišču naj bi bilo odkritih 15 grobov s čeladami, med njimi so najzanesljivejše grobne celote, ki jih hrani Naravoslovni muzej na Dunaju, kjer so inventarizirane štiri dvogrebenaste čelade (sl. 56: 4, 5, 7, 8) in en svojski primerak z narebreno kaloto (sl. 56: 10),⁵²⁹ inventarizirana pa je bila tudi negovska čelada (Preloge, gr. 2/1–2), ki je kasneje izginila. Na Dunaju hrani inštitut pri tamkajšnji univerzi (*Institut für Ur- und Frühgeschichte der Universität Wien*) negovsko čelado iz zbirke kneza Windischgrätza brez ožjih najdiščnih podatkov; objavil jo je Egg (sl. 59) in baje izvira z Magdalenske gore, vendar trdnih dokazov za to ni.⁵³⁰

V prazgodovinski zbirki Narodnega muzeja v Ljubljani so fragmenti dveh sežganih čelad (sl. 56: 1, 2) in en dobro ohranjen dvogrebenasti primerak (sl. 56: 9).⁵³¹ V fragmentu, okrašenem s figuralnim in palmetastim okrasom, je že Dežman prepoznal del čelade (sl. 56: 2),⁵³² kasneje jo je Egg tipološko opredelil kot sestavljeni tip.⁵³³ Nekateri drugi sežgani koščki iz zbirke tega muzeja pa bi lahko pripadali stožčastemu tipu; Teržanova je te

⁵²⁵ Gabrovec 1960b, 37 ss, sl. 2, 10–12; id. 1962–1963; id. 1965b; id. 1965–1966.

⁵²⁶ Gabrovec 1964–1965a, 29 ss; id. 1966a, 15 ss; Frey/Gabrovec 1971.

⁵²⁷ Gabrovec 1987, 69 ss; Dular J. 2003, 99, sl. 51; Gabrovec/Teržan 2008, 273, sl. 42.

⁵²⁸ Razen Gabrovca predvsem Egg 1980; id. 1986, Kat. Nr. 102, 103, 120–125, 168, 301, 302, 323, Abb. 114, 124–128, 176, 182, T. 46b, 48, 58–63, 96, 216, 217, 240; id. 1988a; id. 1988b in Teržan 2007a; ead. 2008, 310 ss, sl. 54–61.

⁵²⁹ Preloge, gr. 2/13, 2/38, 2/57, 13/55, 13/119: Tecco Hvala/Dular/Kocuvan 2008, T. 23, 34, 50, 83, 107.

⁵³⁰ Egg 1986, 50, Kat. Nr. 168, T. 96.

⁵³¹ Tecco Hvala/Dular/Kocuvan 2004, T. 1: 1, 11:1, 172: 3.

⁵³² Deschmann 1884; Kromer/Gabrovec 1962, Y 41–46; Gabrovec 1964–1965b.

⁵³³ Egg 1980.

and hegemonic tendencies among individual centres or among individual families within the centres, which could be inferred from their oscillating power and wealth.⁵¹⁸ In that period, Magdalenska gora became very important and figured at the very top as far as the armament is concerned, as evidenced by the number of burials with weapons as well as the quantity of axes,⁵¹⁹ helmets,⁵²⁰ horses⁵²¹ and other such finds. Within the community, the family occupying pride of place was that burying their dead in Tumulus 2 at Preloge.⁵²²

The changes in the Negova phase may also be understood in the context of events in a wider area and of changed conjuncture, when new centres of power and cultural initiative appeared in central Europe, spreading the La Tène culture. The Dolenjska community was obviously not immune to these events.⁵²³ Its military power was concentrated on the settlements close to the western border of its territory (Vače, Magdalenska gora, Stična, Valična vas, Dolenjske Toplice and Novo mesto), while life on some settlements only just took off in this period (Valična vas, Dolenjske Toplice).⁵²⁴ Magdalenska gora represented an important centre, probably with its own production of shaft-hole axes and other weapons. The highest rank in the military hierarchy of the time was attained by a family burying their dead in Tumulus V at Laščik. Three of its members wore Negova helmets and three were armed with La Tène swords, which thus far represent the only imports in Dolenjska from the original area of the La Tène culture in Lt A. Subsequent events then showed the traditional axe to be no match for the long sword.

4.2 HELMETS

The helmet represents a specific expression of power and sociocultural identity, which also gives it their value in the eyes of the antique collectors. The helmets from the territory of modern Slovenia were first evaluated by Gabrovec, who also established their chronology.⁵²⁵ He used them to name individual phases of the Late Hallstatt period in Dolenjska.⁵²⁶ Of those, the phase of Negova helmets is still in use today.⁵²⁷ The helmets found at Magdalenska gora were included into

⁵¹⁸ Dular/Tecco Hvala 2007, 247 ff, Figs. 138–144; Teržan 2008, Abb. 36, 37.

⁵¹⁹ See here fig. 47.

⁵²⁰ Teržan 1976, 391; ead. 2008, lists to Abb. 55, 57, 59, 61.

⁵²¹ Dular J. 2007b, 737 ff, Abb. 1.

⁵²² Tecco/Hvala/Dular/Kocuvan 2004, Abb. 52.

⁵²³ Dular/Tecco Hvala 2007, 252.

⁵²⁴ Teržan 1973, 679 ff; ead. 1976, 391 f; ead. 2008, 322.

⁵²⁵ Gabrovec 1960b, 37 ff, Abb. 2, 10–12; id. 1962–1963; id. 1965b; id. 1965–1966.

⁵²⁶ Gabrovec 1964–1965a, 29 ff; id. 1966a, 15 ff; Frey/Gabrovec 1971.

⁵²⁷ Gabrovec 1987, 69 ff; Dular J. 2003, 99, Abb. 51; Gabrovec/Teržan 2008, 273, Abb. 42.

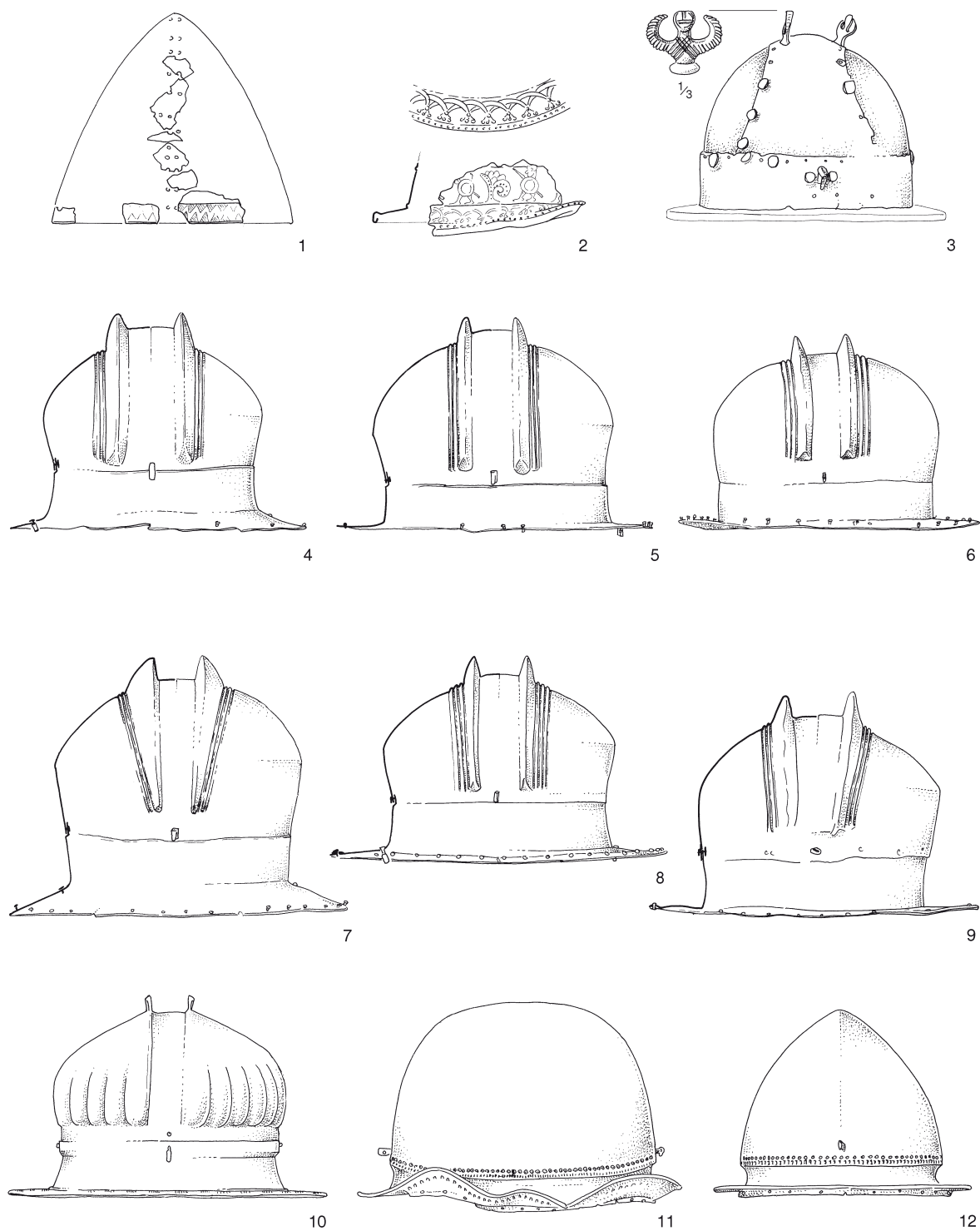

Sl. 56: Tipi čelad z Magdalenske gore. 1 – stožčasta, 2, 3 – sestavljena, 4–9 – dvogrebenasta, 10 – z narebreno kaloto, 11, 12 – negovska. M. = 1:6.

Fig. 56: Types of helmets from Magdalenska gora. 1 – conical, 2, 3 – composite, 4–9 – double-crested, 10 – with ribbed skull, 11, 12 – Negova type. Scale = 1:6.

1 – najdba brez ohranjene grobne celote v NMS (po Teržanovi) / find without preserved context kept in the NMS (after Teržan); 2 – Laščik, gr. 4/1; 3 – Preloge, gr. IV/3; 4 – Preloge, gr. 2/13; 5 – Preloge, gr. 2/57; 6 – Preloge, gr. VII/39; 7 – Preloge, gr. 2/38; 8 – Preloge, gr. 13/119; 9 – Preloge, gr. 2/g; 10 – Preloge, gr. 13/55; 11, 12 – Laščik, gr. V/29.

Gom. / Gr. Tum. / Gr.	Pokop / Burial rite	Spol / Starost Sex / Age	Pokop konja / Horse burial	Tipi čelad / Types of helmets	Št. čelad / No. of helmets	Fibule / Fibulae	Narokvice / Armrings	Pasne sponje / Belts	Pasni okovi / Belt attachments	Sekire / Axes	Sulice / Spears	Puščice / Arrows	Meč / Sword	Noži / Knives	Žezlo / Mace	Raženi / Spit	Dereze / Crampons	Brus / Whetstone	Konjska oprema / Horse gear	Lončena / Pottery	Koščen tul / Bone tube	Bronasto posodje / Bronze vessels
L 12/1	C	M		St?	1?					1	1-2			1			2			3		?
L 4/1	C	M+F?		Se	1	1*	2*															1
P IV/3	S	M		Se	1	1*		1		1												
P 2/g	S	M		D	1	2				1	2											
P VII/39	S	M	x	D	1	1		1		1	2			1					x			
P 2/57	S	M	x	D	1	2		2		1	2			1					x	4		3
P 2/13	S	M	x	D	1			2	x	1	2	50			1		2	1	x	2		4
P 13/119	S	M	x	D	1			1	x	1	2			2						2		1
P 2/38	S	M		D	1		2	1	x	1	1	x				1				1		1
P 13/55	S	M		13/55	1	2		1	x	1	1			1	1			2			2	2
L V/6-7	S	M	x	D/N?	1	2+1		2	x		2+2			1		2			x			3
P IV/32	S	M	x	N?	1	2		1	x		1			1					x	1		2
L V/29	S	M+M	x	N	2		1	2	x		2+4		1	1	1			1	x			4

Sl. 57: Struktura pridatkov v grobovih s čeladami na Magdalenski gori. **D** = dvogrebenasta čelada, **N** = negovska čelada, **Se** = sestavljena čelada, **St** = stožčasta čelada, **13/55** = čelada z narebreno kaloto, * = verjetno ženski pridatki.

Fig. 57: Structure of goods in the graves with helmets at Magdalenska gora. **D** = double-crested helmet, **N** = Negova helmet, **Se** = composite helmet, **St** = conical helmet, **13/55** = helmet with ribbed skull, * = probably female attributes.

fragmente podrobneje preučila in predložila rekonstrukcijo, ki je prikazana na sl. 56: 1.⁵³⁴

V Peabodyjevem muzeju so se z Magdalenske gore znašle ena sestavljena čelada brez ohranjenih krajcev (sl. 56: 3), ena dvogrebenasta (sl. 56: 6), dve negovski čeladi (sl. 56: 11, 12) ter del krajca, ki pripada negovskemu tipu.⁵³⁵

Lega in kontekst. Najstarejši čeladi sta bili nedvomno sežgani s pokojnikom, kar kažejo sledi ognja na fragmentih. Okoliščine odkritja čelade, okrašene v situlskem stilu (sl. 56: 2), je natančno preučil Gabrovec in rekonstruiral pripadajočo grobno celoto.⁵³⁶ Ta grob, ki ga je odkril Schulz pozimi 1881/82 v gomili na južnem koncu grobišča na Laščiku (na ledini Terišče), ima našo oznako 4/1 (sl. 57).⁵³⁷ Koščki stožčaste čelade (sl. 56: 1) pa so morebiti pripadali grobu 12/1 na Laščiku (sl. 26 in sl. 54).⁵³⁸ Za to domnevo bi govorili sledeči razlogi: fragmenti čelade so poškodovani od ognja, kar kaže na to, da so pripadali žganemu pokopu. Ker je čelada izrazito moški statusni simbol najvišjega ranga, je skoraj

numerous other studies,⁵²⁸ wherefore this discussion is mainly aimed at drawing attention to the missing examples and to those grave groups (figs. 56 and 57), where the state in the museum collections and the excavators' notes show inconsistencies.

The cemeteries at Magdalenska gora revealed 15 graves with helmets, of which the most reliable grave groups are those held in the Museum of Natural History in Vienna. In the latter, four double-crested helmets are inventoried (fig. 56: 4, 5, 7, 8) as well as a particular example with a ribbed skull (fig. 56: 10).⁵²⁹ Also inventoried is a Negova helmet (Preloge, Gr. 2/1-2), which is now missing. Another Negova helmet is kept at the Institute for Pre- and Early History of the University of Vienna (*Institut für Ur- und Frühgeschichte der Universität Wien*), from the collection of Prince Windischgrätz without more precise find data; it was published by Egg (fig. 59) and is supposed to have been found at Magdalenska gora, though no hard evidence for this exists.⁵³⁰

⁵²⁸ In addition to Gabrovec see Egg 1980; *id.* 1986, Kat. Nr. 102, 103, 120-125, 168, 301, 302, 323, Abb. 114, 124-128, 176, 182, T. 46b, 48, 58-63, 96, 216, 217, 240; *id.* 1988a; *id.* 1988b and Teržan 2007a; *ead.* 2008, 310 ff, Abb. 54-61.

⁵²⁹ Preloge, Gr. 2/13, 2/38, 2/57, 13/55, 13/119: Tecco Hvala/Dular/Kocuvan 2004, T. 23, 34, 50, 83, 107.

⁵³⁰ Egg 1986, 50, Kat. Nr. 168, T. 96.

⁵³⁴ Teržan 2007a, Fig. 2,2.

⁵³⁵ Hencken 1978, Fig. 39e, 110c, 137, 138, 259a.

⁵³⁶ Gabrovec 1964-1965b.

⁵³⁷ Tecco Hvala/Dular/Kocuvan 2004, 19 s, sl. 13, 15, T. 1.

⁵³⁸ *Ibid.*, 24, sl. 19.

zagotovo pripadala bogatejšemu pripadniku te skupnosti. Takih, ki bi bili sežgani, pa je bilo na Magdalenski gori malo. Glede na to, da se fragmenti čelade hranijo v Narodnem muzeju v Ljubljani, so bili najdeni kvečjemu v okviru Schulzovih ali Pečnikovih izkopavanj, preden je ta začel sodelovati z muzejem na Dunaju in tja pošiljati najdbe. Tako se krog možnih grobov zoži na dva – na grob 4/1, ki ga je Schulz izkopal leta 1882 v gomili na južnem delu grobišča na Laščiku in je po Gabrovčevi rekonstrukciji vseboval fragmente sestavljene čelade z okrasom v situlskem stilu, ter na grob v gomili 12 na severnem koncu tega grobišča, ki ga je odkril Pečnik v začetku leta 1893 in v katerem omenja koščke bronaste posode, ki bi lahko bili tudi deli čelade.

V okviru izkopavanj vojvodinje Mecklenburške na Prelogah je bila leta 1908 najdena sestavljena čelada s sfingo na vrhu kalote (sl. 56: 3). Gre za skeletni grob IV/3, v katerem Goldberg razen čelade omenja še sekuro, fibulo, pasno spono z zakovicami v zelo slabem stanju ter dve jantarni jagodi v obliki rozete. Objavljeni pridatki se ne ujemajo povsem z njegovim opisom, kar se večkrat dogaja z grobnimi celotami iz Mecklenbuške zbirke.⁵³⁹ V opombi je še pripisano, da je bila menda podobna čelada odkrita v nekem grobu dne 21. oktobra 1905, morda skupaj z bodalom.⁵⁴⁰ V tistem letu je vojvodinja kopala na različnih najdiščih (v Dolenjskih Toplicah, Družinski vasi pri Šmarjeti in Gradenju pod Velikim Vinjim vrhom ter v Stični, na Vačah in Magdalenski gori).⁵⁴¹ V Stični je izkopavala od 4. avgusta do 7. septembra (Tumulus I),⁵⁴² na Magdalenski gori pa maja in oktobra, ko je načela prvo gomilo nekje na Prelogah, ki je na terenu nismo uspeli locirati.⁵⁴³ Ta izkopavanja so slabše dokumentirana, o grobovih ni kaj dosti podatkov; glede na omenjeni datum bi bila omenjena čelada lahko najdena kvečjemu v gomili I.

Med magdalenskogorskimi čeladami je največ dvogrebenastih primerkov. V gomili 2 na Prelogah je Pečnik odkril kar štiri grobove s takimi čeladami (sl. 56: 4, 5, 7, 9 in sl. 57). Na prvo med njimi (2/g)⁵⁴⁴ je naletel, ko je še kopal za ljubljanski muzej in o odkritju poročal Centralni komisiji.⁵⁴⁵ Čelada naj bi ležala pri temenu umrlega, ki je bil opremljen z dvema sulicama, sekuro in parom fibul, vendar ju ni podrobneje opisal, kar je seveda škoda, ker grobna celota ni ohranjena. V grobu 2/57 je bil pokojni pokopan skupaj s konjem. Čelado je imel na kolenih, pri nogah pa orožje (tulasto sekuro,

The prehistoric collection of the National Museum in Ljubljana includes fragments of two burnt helmets (fig. 56: 1, 2) and one well preserved double-crested helmet (fig. 56: 9).⁵³¹ The fragment with figural and palmette decoration was identified as part of a helmet already by Deschmann (fig. 56: 2),⁵³² which Egg later determined as the composite type.⁵³³ Some other burnt fragments from the same collection could have belonged to conical helmets; Teržan studied these fragments in more detail and proposed a reconstruction shown on fig. 56: 1.⁵³⁴

The Peabody Museum also holds helmets from Magdalenska gora. It holds one composite helmet preserved without the brim (fig. 56: 3), one double-crested (fig. 56: 6), two Negova helmets (fig. 56: 11, 12) and a brim fragment of a Negova helmet.⁵³⁵

Position and context. The two earliest helmets were undoubtedly cremated with the deceased, as evidenced by traces of fire on the fragments. The find circumstances for the burnt helmet, decorated in the situla art style (fig. 56: 2), were closely examined by Gabrovec, who also reconstructed the helmet's grave group.⁵³⁶ The grave was found by Schulz in the winter of 1881/82 in a tumulus at the southern end of the cemetery at Laščik (Terišče fallow) and is marked 4/1 (fig. 57).⁵³⁷ Pieces of a conical helmet (fig. 56: 1) may have been found in Grave 12/1 at Laščik (figs. 26 and 54).⁵³⁸ Supporting such a supposition is the following. Firstly, the fragments show fire-damage, which indicates a cremation burial. Secondly, helmets being a distinctly male status symbol of the highest rank, it must thus have belonged to a rich male member of the community, of which only a few were cremated at Magdalenska gora. Thirdly, the helmet fragments being kept at the National Museum in Ljubljana, they could only have been found during the excavations of either Schulz or Pečnik, prior to the latter's cooperation with the museum in Vienna. The circle of possible graves thus comes down to two, namely Grave 4/1, which Schulz excavated in 1882 in a tumulus in the southern part of the cemetery at Laščik and which, according to Gabrovč's reconstruction, contained fragments of a composite helmet decorated in the situla art style. The other candidate is the above-mentioned grave in Tumulus 12 from the northern edge of the same cemetery, which Pečnik found in early 1893 and mentioned pieces of a bronze vessel among its goods, whereby the latter could also represent pieces of a helmet.

⁵³⁹ S to problematiko se poglobljeno ukvarja Dragan Božič in v raznih razpravah opozarja na nezanesljivost grobnih celot iz Mecklenburške zbirke (Božič 2009; id. 2010, druge razprave so v pripravi za tisk).

⁵⁴⁰ Hencken 1978, 17 s, op. 4.

⁵⁴¹ Dular J. 2003, 83.

⁵⁴² Wells 1981, 48; Gabrovec 2008, 35.

⁵⁴³ Hencken 1978, 11.

⁵⁴⁴ Egg 1986, Abb. 15.

⁵⁴⁵ Tecco Hvala/Dular/Kocuvan 2004, 30.

⁵³¹ Tecco Hvala/Dular/Kocuvan 2004, T. 1: 1, 11:1, 172: 3.

⁵³² Deschmann 1884; Kromer/Gabrovec 1962, Y 41–46; Gabrovec 1964–1965b.

⁵³³ Egg 1980.

⁵³⁴ Teržan 2007a, Fig. 2,2.

⁵³⁵ Hencken 1978, Figs. 39e, 110c, 137, 138, 259a.

⁵³⁶ Gabrovec 1964–1965b.

⁵³⁷ Tecco Hvala/Dular/Kocuvan 2004, 19, 118 f, Abb. 13, 15, T. 1.

⁵³⁸ *Ibid.*, 24, 123, Abb. 19.

sulici in nož), posode z bronastimi pokrovi ter konjsko opremo. K njegovi opravi so spadale še dve kačasti fibuli s krilci in dve pasni sponi, od katerih je ena v celoti železna, druga pa bronasta z okrasom koncentričnih krožcev.⁵⁴⁶ Podobno čelado je imel tudi konjenik – lokostrelec, pokopan v grobu 2/13; ležala mu je na prsih, razen tega so mu bili pridani komplet orožja, brus, železne dereze, pasna spona (okrašena s sfingami), žezlo (*sl.* 54) in posodi z bronastima pokrovoma. Bogato okrasje je imel tudi njegov konj, ki so mu priložili celo bronast kotliček.⁵⁴⁷ Četrta dvogrebenasta čelada iz te gomile je bila najdena v grobu 2/38. Umrlj jo je imel pri kolenih, zraven pa neokrašeno bronasto pasno spono z jezlički, tulasto sekuro, nož in puščične osti; imel je še glinasto posodo, menda okrašeno z zlato peno, ter bronasto kelihasto posodo, pod katero je ležal raženj.⁵⁴⁸

Dvogrebenasto čelado je nosil tudi pripadnik gomile 13 na Prelogah, pokopan v grobu 13/119 skupaj s konjem, ki pa ni imel ne brzd ne okrasja. Med pridatki so zabeleženi bronasta pravokotna pasna spona brez okrasa, običajen komplet orožja (tulasta sekira, par suličnih osti, nož) ter bronasta situla z geometrijskim okrasom in dva glinasta ciborija.⁵⁴⁹ Ta družina je dala še enega častivrednega moža (13/55), ki je imel unikatno čelado z narebreno kaloto (*sl.* 56: 10), žezlo, tulasto sekuro, sulico in nož, pasno spono in par certoških fibul vrste XIII ter dragocen servis posodja (bronasto situlo s figuralnim okrasom in cisto). Konja sicer ni imel, je pa bila morda z njim pokopana spremljevalka v onostranstvo (*sl.* 34: *levo*).⁵⁵⁰

Ena dvogrebenasta čelada je objavljena v sklopu grobne celote VII/39 s Prelog (*sl.* 56: 6), vendar ni istovetna s primerkom na fotografiji tega groba (*sl.* 58). To je vojvodinja Mecklenburška dozdevno podarila nemškemu cesarju Wilhelmu II. in je danes v berlinskem muzeju.⁵⁵¹

O slabo ohranjeni dvogrebenasti čeladi poroča Goldberg še v zvezi z grobom konjenika V/6–7a–7 z Laščika, kot taka se omenja tudi v katalogu *Treasures of Carniola*.⁵⁵² V objavi te grobne celote pa nastopa del krajca, ki ga je Hencken komentiral z besedami: "Temu Goldberg pravi slabo ohranjena dvogrebenasta čelada, v resnici pa gre za del negovske čelade."⁵⁵³ Glede na že večkrat dokazano kontaminiranost grobnih celot v Mecklenburški zbirki, je pri presoji verjetno potrebno dati prednost primarnemu viru. Dvogrebenasti tip če-

The 1908 excavations by the Duchess of Mecklenburg at Preloge revealed a composite helmet with a sphinx topping the skull (*fig.* 56: 3). It was found in inhumation Grave IV/3, for which Goldberg further mentions an axe, a fibula, a poorly preserved belt clasp with rivets and two rosette-shaped amber beads. The published grave goods do not entirely correspond to his description, which is not infrequent for the grave groups from the Mecklenburg Collection.⁵³⁹ Goldberg added in a note that a similar helmet had been found in a grave on 21 October 1905, possibly together with a dagger.⁵⁴⁰ In that year, the Duchess dug on several sites (Dolenjske Toplice, Družinska vas near Šmarjeta, Gradenje near Veliki Vinji vrh, Stična, Vače and Magdalenska gora).⁵⁴¹ From August 4 to September 7, she excavated at Stična (Tumulus I),⁵⁴² and in May and October at Magdalenska gora, where she began digging the first tumulus somewhere at Preloge that we were unable to locate.⁵⁴³ These excavations are poorly documented, with not much data existing on individual graves. Considering the date, however, the helmet could only have been found in Tumulus I.

Most of the helmets from Magdalenska gora belong to the double-crested type. In Tumulus 2 at Preloge, Pečnik found as many as four graves with such helmets (*fig.* 56: 4, 5, 7, 9 and *fig.* 57). He found the first (2/g)⁵⁴⁴ while still digging for the museum in Ljubljana and reported on it to the Central Commission.⁵⁴⁵ The helmet supposedly lay at the top of the head of the deceased, who was further equipped with two spears, an axe and a pair of fibulae. The finds were not described in detail, which is all the more unfortunate due to the fact that the grave group has not been preserved. Grave 2/57 revealed a male buried together with a horse. The helmet was found on his knees, while at his feet were the weapons (socketed axe, two spears and a knife), vessels with bronze lids and horse gear. His outfit further included two serpentine fibulae with wings and two belt clasps, one of which made entirely of iron and the other of bronze decorated with concentric circles.⁵⁴⁶ A similar helmet was found on a chest of a horseman – archer buried in Grave 2/13. He also had a set of weapons, whetstone, iron crampons, belt clasp (decorated with sphinxes), a mace (*fig.* 54) and two vessels with bronze lids. His horse was richly adorned and was offered a bronze cauldron.⁵⁴⁷ The fourth double-crested helmet

⁵³⁹ This subject is studied by Dragan Božič, who draws attention to the untrustworthiness of the grave groups in the Mecklenburg Collection (Božič 2009; *id.* 2010 and in other forthcoming treatises).

⁵⁴⁰ Hencken 1978, 17 f, n. 4.

⁵⁴¹ Dular J. 2003, 83.

⁵⁴² Wells 1981, 48; Gabrovec 2008, 35.

⁵⁴³ Hencken 1978, 11.

⁵⁴⁴ Egg 1986, Abb. 15.

⁵⁴⁵ Tecco Hvala/Dular/Kocuvan 2004, 30, 126.

⁵⁴⁶ *Ibid.*, 44, 135 f, T. 50–52.

⁵⁴⁷ *Ibid.*, 35, 129, T. 23–27.

⁵⁴⁶ *Ibid.*, 44 s, T. 50–52.

⁵⁴⁷ *Ibid.*, 35 s, T. 23–27.

⁵⁴⁸ *Ibid.*, 39 s, T. 34–36.

⁵⁴⁹ *Ibid.*, 72, T. 107–109.

⁵⁵⁰ *Ibid.*, 61 s, sl. 31, T. 83–85.

⁵⁵¹ Egg 1986, 182, Kat. Nr., 129, T. 66a; Weiss 1999, 62, 71; Born 2008, 142, sl. 10.

⁵⁵² Mahr (ur.) 1934, 115. Na neskladje je opozoril že Gabrovec 1962–1963, 308.

⁵⁵³ Hencken 1978, 30 s.

lade bi s kronološkega vidika ne bil v opreki z drugimi pridatki v tem grobu, ki jih našteva Goldberg (konjska oprema, bronast kotliček, pravokotna pasna spona in druga v predrti tehniki v obliki ptice, nadalje dve fibuli, speti z verižico, certoška fibula, ražnja, cista, zdrobljena situla – okrasa na njej ne omenja!).

Poleg fragmenta krajca negovske čelade sta v Mecklenburški zbirki ohranjena še dva cela primerka tega tipa v sklopu dvojnega groba V/29 (*sl.* 56: 11, 12). Situacija tudi v tem primeru ni najbolj jasna. Po Goldbergovem opisu je "grdo obtolčena" čelada ležala 70 cm višje od druge; obrnjena je bila s krajci navzgor, v njej so bile modro-rumene steklene jagode, obkrožali in deloma prekrivali pa so jo za pest veliki kamni. Druga negovska čelada v tem grobu ni bila poškodovana, ležala je obrnjena s krajci navzdol, v bližini so bili ostanki človeških kosti in druga oprema, ki so jo sestavljali spiralna narokvica, žezlo, orožje, brus, cista, situla z okrasom v obliki krožcev, dve pravokotni pasni sponi (ena je imela figuralni okras) ter konjska oprema, zraven so bili pokopani štirje konji, skupaj z dvema bronastima kotličkoma. Hencken ugotavlja, da je tudi v tem primeru predmetov več, kot jih je navedel Goldberg.⁵⁵⁴

Goldberg omenja čelado še v grobu IV/32, ki je ni podrobneje opisal, za njo pa se je izgubila sleherna sled. Ta tako imenovani Konjski grob II naj bi ležal bolj na obrobju gomile kot pa v njej. Med pridatki našteva "dve fibuli z diski", bronasto pravokotno pasno spono, pasni obroček, sulično ost, nož, okrašeno koščeno platišče, bronast kotliček, situlo in majhen lonec.⁵⁵⁵

V zbirki dunajskega Naravoslovnega muzeja je prav tako pogrešana ena negovska čelada, ki je bila inventarizirana med najdbami groba 2/1–2 s Prelog. O tem grobu ni drugih poročil, vendar je šlo sodeč po številu sekir, fibul in steklenih jagodah verjetno za več pokopov, ki niso vsi iz istega časa.⁵⁵⁶

En primerek negovske čelade objavlja Egg iz Windischgrätzove zbirke (*sl.* 59).⁵⁵⁷ Če bi zares izvirala z Magdalenske gore, kot se domneva, bi bilo možno, da jo je izkopala vojvodinja Mecklenburška in jo podarila knezu, ki je bil njen sorodnik in velik zbiratelj starin,⁵⁵⁸ vendar je to zgolj ugibanje.

Nazadnje je treba omeniti še fragmentirano čelado, ki je v lasti Janeza J. Švajncerja, zbiratelja starin in ustanovitelja Vojnega muzeja v Logatcu. V svojem nedavno objavljenem prispevku je predstavil zbir najdb, ki menda izvirajo z Magdalenske gore, žal pa podatki o okoliščinah odkritja, najditelju in natančnejšem mestu izkopa niso znani. Zagotovo gre za pridatke iz več grobov, med njimi je tudi krajec s štulo čelade, ki nima ohranjene kalote, na krajcu pa so vtisnjene pismenke oz. napis, ki ga je

⁵⁵⁴ *Ibid.*, 36 ss.

⁵⁵⁵ *Ibid.*, 23.

⁵⁵⁶ Tecco Hvala/Dular/Kocuvan 2004, 32 s, T. 15, 16.

⁵⁵⁷ Egg 1986, Kat. Nr. 168, T. 96.

⁵⁵⁸ Dular J. 2009a, 32.

from this tumulus was found in Grave 2/38. It was laid at the knees of the deceased, beside an undecorated bronze belt clasp and belt attachments, a socketed axe, a knife and arrowheads. The deceased was further offered a clay vessel, reportedly decorated with gold leaf, a bronze goblet-like vessel and a spit underneath the latter.⁵⁴⁸

A double-crested helmet was also worn by a man buried in Tumulus 13 at Preloge, in Grave 13/119 together with a horse, the latter without bridle-bit or adornments. The recorded grave goods consist of an undecorated bronze belt clasp, usual set of weapons (socketed axe, pair of spearheads, knife), a bronze situla with geometric decoration and two clay footed bowls.⁵⁴⁹ This family had another honourable member (13/55), who was buried with a unique helmet with a ribbed skull (*fig.* 56: 10), mace, socketed axe, spear and a knife, a belt clasp, pair of Type XIII Certosa fibulae and a valuable set of vessels (bronze situla with figural decoration and cist). He was not buried with a horse, but might have had a female companion into the afterlife (*fig.* 34: A).⁵⁵⁰

One double-crested helmet was published as part of the goods from Grave VII/39 at Preloge (*fig.* 56: 6), though it is not the helmet featured on the photo of the grave in question (*fig.* 58). This helmet was presumably offered by the Duchess of Mecklenburg to German Emperor Wilhelm II and is today kept at the museum in Berlin.⁵⁵¹

A poorly preserved double-crested helmet is reported by Goldberg in connection with Grave V/6–7a–7 of a horseman at Laščik. It is mentioned as such also in the catalogue of *Treasures of Carniola*.⁵⁵² The publication of the grave group only includes a brim fragment, "what Goldberg called a badly preserved double-crested helmet, but which was really part of a Negau helmet," as commented by Hencken.⁵⁵³ Considering the cases of contamination of the grave groups in the Mecklenburg Collection, however, the final judgement should probably give priority to the primary source. From the standpoint of chronology, a double-crested type of helmet would also not be in opposition to the other grave goods listed by Goldberg (horse gear, small bronze pot, rectangular belt clasp and an openwork belt clasp in the shape of a bird, two fibulae tied with a chain, a Certosa fibula, two spits, a cist, a crushed situla – no mention of its decoration!).

Apart from the brim fragment of a Negova helmet, the Mecklenburg Collection also includes two complete examples of the helmet type found in double Grave V/29 (*fig.* 56: 11, 12). The situation is not entirely clear even for

⁵⁴⁸ *Ibid.*, 39, 132, T. 34–36.

⁵⁴⁹ *Ibid.*, 72, 157, T. 107–109.

⁵⁵⁰ *Ibid.*, 61, 149, Abb. 31, T. 83–85.

⁵⁵¹ Egg 1986, 182, Kat. Nr., 129, T. 66a; Weiss 1999, 62, 71; Born 2008, 142, Abb. 10.

⁵⁵² Mahr (ed.) 1934, 115. Gabrovec (1962–1963, 308) also pointed out this discord.

⁵⁵³ Hencken 1978, 30 f.

Švajncer prikazal v prepisu.⁵⁵⁹ Čelada pripada ali dvo-grebenastemu ali negovskemu tipu, o napisu pa bi lahko presojali strokovnjaki, če bodo imeli kdaj priložnost, da ga podrobneje preučijo.

Razširjenost in časovni okvir. Pojav čelad v jugovzhodnoalpskem svetu in njihovo kronološko sosledje sta že dodobra preučena. Njihovo vlogo in pomen v dolenski halštatski družbi je nazadnje osvetlila Teržanova in ovrednotila odnose med dolenskimi najdišči.⁵⁶⁰ Iz številčnega razmerja posameznih tipov (*sl. 60*) se jasno kaže, da so bile skledaste, dvogrebenaste in negovske čelade "udomačene" v halštatskih bojevnih opravah tega prostora. Redkejši so stožčasti, koničasti in ilirski tip.

STOŽČASTE ČELADE

Ta tip (*sl. 56: 1*) predstavlja poleg skledastih čelad najstarejšo obliko na Dolenskem, kjer sta znana dva primerka – eden z Magdalenske gore in drugi iz Sel nad Gorenjim Vrhpoljem.⁵⁶¹ Čeprav grobni celoti nista ohranjeni, predstavljata pomemben kašipot povezav med picenskim prostorom in vzhodnimi Alpami, ki so potekale prek Jadranskega morja in Istre.⁵⁶² V Picenumu se take čelade pojavijo v zadnjih desetletjih 8. st. pr. n. št.⁵⁶³ Na drugi strani jo je okoli leta 700 nosil kleinkleinski veljak, opremljen z oklepom, antenskim mečem tipa Tarquinia in sekiro z dvostranskimi plavutmi (Hartnermichelkogel 1).⁵⁶⁴ Vzore za stožčaste čelade je moč iskati v daljnem vzhodnosredozemskem prostoru,⁵⁶⁵ enako kot za koničasti tip, ki je zastopan v Stični.⁵⁶⁶ Sočasne so skledastim čeladam, ki so bile tedaj razširjene v vzhodnoalpskem in predalpskem svetu in "spadajo med značilne attribute elitnih bojevnikov, glavarjev rodov v času formativne faze", kot je napisala Teržanova.⁵⁶⁷ Na Magdalenski gori skledastih čelad ni; najbližji tak primerki je bil najden na Molniku v žarnem grobu 3/6 s krasnim servisom, v katerem je bronasta ročka,⁵⁶⁸ ki ima paralele v Hallstattu.⁵⁶⁹ Tam je zabeleženih kar 11 skledastih čelad, med njimi tudi različica Molnik, kot jo je poimenoval Škoberne. V to različico je uvrstil še primerke iz okolice Velikega

this grave. According to Goldberg, one "badly crushed" helmet was found, brim up, 70cm above the other helmet. It contained blue-yellow glass beads and was surrounded and partly covered by fist-sized stones. The other Negova helmet was undamaged, found brim down near the remains of human bones and other goods such as a spiral armlet, mace, weapons, a whetstone, a cist, a situla decorated with concentric circles, two rectangular belt clasps (one with figural decoration) and horse gear. Also buried in the grave were four horses with two bronze cauldrons. Hencken observed that this grave as well contained more objects than cited by Goldberg.⁵⁵⁴

Goldberg mentions another helmet in Grave IV/32, now lost, without offering a detailed description. This grave, also named Horse Grave II, was supposedly found more on the edge of the tumulus than in it. As for grave goods, he lists "two fibulae with discs", a bronze rectangular belt clasp, a belt ring, a spearhead, a knife, a decorated bone mount, a bronze cauldron, a situla and a small jar.⁵⁵⁵

One Negova helmet is missing also from the collection of the Museum of Natural History in Vienna, where it was inventoried among the finds from Grave 2/1–2 at Preloge. The grave featured in no other report, though the number of axes, fibulae and glass beads indicate several burials from different phases.⁵⁵⁶

Another example of a Negova helmet was published by Egg as part of the Windischgrätz Collection (*fig. 59*).⁵⁵⁷ If the supposition on its Magdalenska gora origin were true, it would very likely have been excavated by the Duchess of Mecklenburg, who offered it to the Prince, her relative and a keen antique collector.⁵⁵⁸ This, however, is mere speculation.

Finally, I should also mention the fragmented helmet now in the possession of Janez Švajncer, collector of antiquities and founder of the Logatec War Museum. In his recently published article, he presents a collection of finds reportedly from Magdalenska gora, though unfortunately not equipped with the data on the find circumstances, the finder and the precise location. The objects certainly represent the goods of several graves. They include a brim fragment of a helmet without the skull part, whereby the fragment bears impressed letters or an inscription, presented by Švajncer in transcription.⁵⁵⁹ The helmet is either double-crested or Negova in type, while the inscription might be studied by experts if they are ever given the opportunity.

Distribution and time frame. The appearance of helmets in the south-eastern Alpine world and their

⁵⁵⁹ Švajncer 2012, 5.

⁵⁶⁰ Teržan 2007a; ead. 2008, 310 ss, sl. 54–61.

⁵⁶¹ Gabrovec 1960b, sl. 15: 1; Dular J. 2003, 180; Teržan 2007a, Fig. 2.1.

⁵⁶² Teržan 2007a, 39 ss, Fig. 1 z navedbo literature.

⁵⁶³ Beinbauer 1985, Typentafel C, Abb. 42.

⁵⁶⁴ Egg 2004a, 105; id. 2009, 40, Abb. 4, 7: 2.

⁵⁶⁵ Hencken 1971, 17 ss; Teržan 2007a, 42 ss, Fig. 4, 5.

⁵⁶⁶ Teržan 2008, 268, sl. 31.

⁵⁶⁷ *Ibid.*, 311 ss, sl. 54, 55.

⁵⁶⁸ Puš 1991, 38–41.

⁵⁶⁹ Kromer 1959b, T. 23: 1, 30: 9, 49: 12, 51: 2; Hodson 1990, 114: Fig. 3: 17110, 17120, Pl. 10: 4, 17: 4, 19: 1, 32: 3; Steiner 1999, 79 ss, Abb 2.

⁵⁵⁴ *Ibid.*, 36 ff.

⁵⁵⁵ *Ibid.*, 23.

⁵⁵⁶ Tecco Hvala/Dular/Kocuvan 2004, 127, T. 15, 16.

⁵⁵⁷ Egg 1986, Kat. Nr. 168, T. 96.

⁵⁵⁸ Dular J. 2009a, 32.

⁵⁵⁹ Švajncer 2012, 5.

Vinjega vrha oz. Šmarjete, Stične, Bleda in Mitterkirchna ter na drugi strani čelado iz groba Lippi 85 v Verucchio na Apeninskem polotoku.⁵⁷⁰ V Verucchio pa je bil najden tudi bronast ročaj podobne posode,⁵⁷¹ kot so izpričane na Molniku ali v Hallstattu, kar dodatno potrjuje navezo med alpskim in italiskim svetom tistega časa, v kateri je Dolenjska predstavljala vmesni člen.

SESTAVLJENE ČELADE

Tovrstne čelade so na teritoriju dolenske halštatske skupnosti predstavljale dokaj redek in kratkotrajen pojav, časovno omejen na stopnjo Stična, zato je Teržanova podvomila, da gre za dolenske izdelke,⁵⁷² kot sta predpostavljala Gabrovec in Egg.⁵⁷³ Glede odnosa med skledastim in sestavljenim tipom je Gabrovec ugotavljal, da se je sestavljena čelada pojavila v času, ko je bila še v uporabi skledasta čelada, vendar je ne zasledimo na tistih najdiščih, kjer je številneje zastopan skledasti tip (npr. Veliki Vinji vrh oz. Šmarjeta, Hallstatt),⁵⁷⁴ kar morda ni naključje. Na Magdalenski gori sta se s sestavljeno čelado (sl. 56: 2, 3) ponašala kar dva predstavnika, morda celo trije.⁵⁷⁵ Tisti, ki je posedoval primerek, na katerem so upodobljeni hopliti in palmetast preplet, je bil kremiran in pokopan nemara skupaj z družico v svoji gomili na južnem koncu grobišča na Laščiku (4/1). Pokojnik iz groba IV/3, čigar čelado je krasila sfinga, je pripadal rodu gomile IV na Prelogah, v kateri je bilo odkritih skupno 66 grobov.⁵⁷⁶ Angel, ki je opravil antropološko analizo okostja iz tega groba, je pokojnika opredelil kot mladega moškega z mešanimi alpskimi potezami, visokega 174 cm.⁵⁷⁷ Ne glede na dilemo, ali so te čelade domači izdelek ali ne, je ideja oz. pobuda zagotovo prišla najsi bo iz picenskega ali iz severnoitalskega prostora. Protom v obliki sfinge, upodobitev hoplitov, palmetast preplet spadajo v orientalizirajočo motiviko, ki se pojavlja tudi v situlski umetnosti.⁵⁷⁸ Protome v obliki sfinge imata tudi sestavljeni čeladi iz Brezja (gr. 1/37) in z Vač (grob s čelado), primerek iz Novega mesta (grob z oklepom) pa ima poleg tega še palmetast preplet na krajcih. Vsi trije omenjeni grobovi so bili skeletni.⁵⁷⁹ Manj verjetna

⁵⁷⁰ Škoberne 1999, 68 ss, sl. 58, 67; Gentili 2003, T. 135: 40, VII: a; Malnati 2004, Fig. 4.

⁵⁷¹ Gentili 2003, T. 114: 73, CCXVIII: 72.

⁵⁷² Teržan 2008, 315.

⁵⁷³ Gabrovec 1965–1966, 83; Egg 1986, 29 ss, Kat. Nr. 98–107. Gre za t. i. jugovzhodnoalpski tip po Eggju.

⁵⁷⁴ Gabrovec 1962–1963, 313.

⁵⁷⁵ En primerek je bil menda najden dne 21. oktobra 1905 (morda v gomili I na Prelogah): glej Hencken 1978, 11, 18, op. 4.

⁵⁷⁶ Hencken 1978, 17.

⁵⁷⁷ Angel 1968, 95 s.

⁵⁷⁸ Gabrovec 1964–1965b; Egg 1996, 45 ss, Abb. 27.

⁵⁷⁹ Gabrovec 1960b; id. 1965–1966; Egg 1986, Kat. Nr. 100, 104, 106, Abb. 112, 115: 1, 116, T. 45, 46a, 49a.

chronological sequence are well studied topics. The last to shed light on their role and significance within the Dolenjska Hallstatt society was Teržan, who used them as basis for evaluating the relationships between individual sites.⁵⁶⁰ The numerical representation of individual types (fig. 60) clearly shows that bowl-shaped, double-crested and Negova helmets were quite “domesticated” in the Hallstatt warrior outfit of the area, while the conical, ogival and Illyrian types were rarer.

CONICAL HELMETS

This type (fig. 56: 1) represents, together with the bowl-shaped type, the earliest form of helmets in Dolenjska. Two examples were found, one at Magdalenska gora and the other at Sela near Gorenje Vrhpolje.⁵⁶¹ In spite of their grave groups not being preserved, they nevertheless represent important indicators of the connections between Picenum and the eastern Alps, which ran across the Adriatic and Istria.⁵⁶² This helmet type appears in Picenum in the last decades of the eighth century BC.⁵⁶³ It was also worn, around 700 BC, by a dignitary from Kleinklein (Hartnermichelkogel 1), together with a cuirass, a Tarquinia type antenna sword and a winged axe.⁵⁶⁴ Models for this helmet type are to be sought in the eastern Mediterranean,⁵⁶⁵ the same as for the ogival helmet, one of which was found at Stična.⁵⁶⁶ Conical helmets are contemporary with bowl-shaped helmets, which were frequent in the eastern and subalpine areas. As formulated by Teržan, they represent one of the characteristic attributes of elite warriors, chieftains during the formative phase.⁵⁶⁷ No bowl-shaped helmets have been found at Magdalenska gora; the nearest example was unearthed at Molnik, in urn Grave 3/6 with an excellent set of vessels that include a bronze vessel with handle⁵⁶⁸ with parallels at Hallstatt.⁵⁶⁹ The latter site revealed as many as 11 bowl-shaped helmets, among them also the Molnik variant, as named by Škoberne. The group of the Molnik variant bowl-shaped helmets include examples found near Veliki Vinji vrh (Šmarjeta), Stična, Bled and Mitterkirchen, as well as the helmet from Grave Lippi 85 at Verruchio on the Apennine Pe-

⁵⁶⁰ Teržan 2007a; *ead.* 2008, 310 ff, Abb. 54–61.

⁵⁶¹ Gabrovec 1960b, Abb. 15: 1; Dular J. 2003, 180; Teržan 2007a, Fig. 2.1.

⁵⁶² Teržan 2007a, 39 ff, Fig. 1 with references.

⁵⁶³ Beinbauer 1985, Typentafel C, Abb. 42.

⁵⁶⁴ Egg 2004a, 105; *id.* 2009, 40, Abb. 4, 7: 2.

⁵⁶⁵ Hencken 1971, 17 ff; Teržan 2007a, 42 ff, Fig. 4, 5.

⁵⁶⁶ Teržan 2008, 268, Abb. 31.

⁵⁶⁷ *Ibid.*, 311 ff, Abb. 54, 55.

⁵⁶⁸ Puš 1991, 38–41.

⁵⁶⁹ Kromer 1959b, T. 23: 1, 30: 9, 49: 12, 51: 2; Hodson 1990, 114: Figs. 3: 17110, 17120, Pl. 10: 4, 17: 4, 19: 1, 32: 3; Steiner 1999, 79 ff, Abb. 2.

je pripadnost fragmenta sestavljene čelade grobni celoti V(50)/15 iz Stične, v kateri Goldberg omenja dvogrebenasto čelado.⁵⁸⁰ Po ugotovitvah Božiča bi ta fragment krajca skupaj z drugim odlomkom v Mecklenburški zbirki iz Vinice lahko pripadal čeladi z Magdalenske gore (Preloge, gr. IV/3), ki je objavljena brez krajev.⁵⁸¹

DVOGREBENASTE ČELADE

Čelada, ki jo je vojvodinja podarila nemškemu cesarju (*sl.* 58) in dozdevno pripada magdalenskogorskemu grobu VII/39 iz gomile na Prelogah,⁵⁸² se razlikuje od drugih dvogrebenastih primerkov z območja Dolenjske, ki jih je Egg opredelil kot jugovzhodnoalpsko različico (*sl.* 56: 4–9).⁵⁸³ Na njej je moč opaziti nekatere starejše poteze: po načinu pritrditve štule na kaloto je podobna sestavljenima čeladama iz Brezja in z Vač,⁵⁸⁴ po obliki kalote spominja na čelado iz Populonije iz časa okoli leta 600;⁵⁸⁵ po vodoravnih okrasnih rebrih na štuli pa je sorodna čeladi iz Býčí skále, ki jo Parzinger, Trefný in Naso datirajo v prvo polovico 6. st. pr. n. št. in zanjo menijo, da morda predstavlja derivat picenskih modelov.⁵⁸⁶ V ta čas spada tudi grob VII/39 z Magdalenske gore glede na pridano kačasto fibulo, kar pomeni, da predstavlja najstarejšo grobno celoto s tovrstno čelado na Dolenjskem. Da so jih kmalu začeli izdelovati v domačih delavnicah, priča drug grob z Magdalenske gore (Preloge, gr. 2/57), v katerem nastopa skupaj s kačastima fibulama s krilci. V polni meri pa so se uveljavile v elitnih vojaških opravah iz certoške stopnje, ko bi jih lahko celo opredelili kot zaščitni znak dolenjske konjenice.⁵⁸⁷ Po bogastvu in insignijah izstopa pripadnik magdalenskogorske skupnosti, poko-

⁵⁸⁰ Gabrovec 1962–1963, 308, T. 9: 2; Wells 1981, 71, Fig. 125f; Egg 1986, 32, 167, Kat. Nr. 105, Abb. 115: 2, T. 49b; Teržan 2008, sl. 32; Božič 2010, 167 ss, Abb. 13–15.

⁵⁸¹ Božič 2010, 167 ss, Abb. 11–13.

⁵⁸² Kot najdišče nastopa tudi Stična: Gabrovec 1962–1963, 307; Egg 1986, Kat. Nr. 129, T. 66.

⁵⁸³ Egg 1986, 35 ss, 173 ss, Kat. Nr. 118–138, Abb. 122–136, T. 56–70, 73a; Teržan 2008, 317 ss, sl. 58, 59.

⁵⁸⁴ Štula je pri sestavljenih čeladah pritrjena na zunanji strani kalote z vrsto zakovic, ki jih zgoraj in spodaj obrobljata okrasni vodoravno potekajoči rebri, medtem ko je pri dvogrebenastih čeladah zgornji del štule skrit pod kaloto in ni v nobenem primeru okrašen. Za primerjavo glej Egg 1986, Abb. 112, 116, T. 45, 50, 66a, 73b.

⁵⁸⁵ Gabrovec 1962–1963, 307, 310, T. 20: 1; Egg 1986, 39 s, Kat. Nr. 139, T. 73b.

⁵⁸⁶ Parzinger et al. 1995, 59, T. 25: 290; Trefný 2002, 360 s, Abb. 1; Naso 2007, 27, Fig. 3.

⁵⁸⁷ *Dobrnič, gr. 7/5*: Parzinger 1988–1989, 550, T. 7: 8; *Libna-Špilerjeva gom. 2/gr. 1*: Guštin 1976, T. 1–3; *Novo mesto-Znančeve njive, gr. 1/23*: Knez 1986, T. 6; *Stična, gr. V(50)/15(?)*, *VI(55?)/30*: Wells 1981, 71, 80, Fig. 125, 160; Egg 1986, Abb. 15; Teržan 2008, 269, sl. 32–34, 36; *Magdalenska gora-Preloge, gr. 2/13, 2/38, 2/57, 13/119*, in morda *Laščik, gr. V/6–7–7a (?)*.

ninsula.⁵⁷⁰ The site of Verucchio also yielded a bronze handle of a vessel⁵⁷¹ similar to those attested to at Molnik and Hallstatt. The latter offers additional evidence as to the connections between the Alpine and Italic worlds of the period, a link between which was represented by Dolenjska.

COMPOSITE HELMETS

Such type of helmets had a fairly rare and short-lived appearance on the territory of the Dolenjska Hallstatt community, chronologically limited to the Stična phase. This led Teržan to doubt the helmets to be made in Dolenjska,⁵⁷² as had been supposed by Gabrovec and Egg.⁵⁷³ On the subject of the relationship between the bowl-shaped and composite types, Gabrovec observed that the latter appeared at a time when the former was still in use, though not at the sites with a more important presence of the bowl-shaped type (for example Veliki Vinji vrh (Šmarjeta), Hallstatt),⁵⁷⁴ which may not be a coincidence. At Magdalenska gora, a composite helmet (*fig.* 56: 2, 3) was found with two, possibly three individuals.⁵⁷⁵ The deceased with the helmet decorated with hoplites and a mesh of palmettes was cremated and possibly buried with a female companion in his own tumulus on the southern end of the cemetery at Laščik (4/1). The deceased in Grave IV/3, whose helmet was adorned by a sphinx, belonged to the clan buried in Tumulus IV at Preloge, which revealed altogether 66 graves.⁵⁷⁶ Angel, who performed an anthropological analysis of the bones from this grave, determined the deceased as a 174cm tall, young male with mixed Alpine traits.⁵⁷⁷ Setting aside the dilemma of these helmets being made in Dolenjska or not, the idea or the initiative came either from Picenum or northern Italy. Sphinx protome, depictions of hoplites and palmette mesh are all Orientalising motifs that also appear in the situla art.⁵⁷⁸ Sphinx protomes can further be found on two composite helmets from Brezje (Gr. 1/37) and Vače (grave with a helmet), while the helmet from Novo mesto, found in a grave with a cuirass, also bears a palmette mesh on the brim. All three burials

⁵⁷⁰ Škoberne 1999, 68 ff, Figs. 58, 67; Gentili 2003, T. 135: 40, VII: a; Malnati 2004, Fig. 4.

⁵⁷¹ Gentili 2003, T. 114: 73, CCXVIII: 72.

⁵⁷² Teržan 2008, 315.

⁵⁷³ Gabrovec 1965–1966, 83; Egg 1986, 29 ff, Kat. Nr. 98–107. Egg defined them as the South-Eastern Alpine type.

⁵⁷⁴ Gabrovec 1962–1963, 313.

⁵⁷⁵ One example was reportedly found on 21 October 1905 (possibly in Tumulus I at Preloge?): see Hencken 1978, 11, 18, n. 4.

⁵⁷⁶ Hencken 1978, 17.

⁵⁷⁷ Angel 1968, 95 f.

⁵⁷⁸ Gabrovec 1964–1965b; Egg 1996, 45 ff, Abb. 27.

pan v grobu 2/13 na Prelogah, ki je bil morebiti izbran celo za poveljnika dolenjske vojske. V tem času je magdalenskogorska skupnost izkazala tudi svojo izvirnost z edinstvenim primerkom čelade, ki ima narebreno kaloto, pripadala pa je pokojniku v grobu 13/55 na Prelogah. V okrasu je Teržanova prepoznala motiv cvetnih listov, v katerem se morebiti skriva simbolno sporočilo v smislu "garanta za varnost in moč".⁵⁸⁸ Simbolno sporočilo nosi tudi bronasta figuralno okrašena situla, ki mu je bila pridana v grob skupaj z drugim dragocenim posodjem;

⁵⁸⁸ Teržan 2007b, 89.



Sl. 58: Dvogrebenasta čelada, domnevno iz groba VII/39 (po Weissu 1999, Abb. 63, T. 19).

Fig. 58: Double-crested helmet, presumably from Grave VII/39 (after Weiss 1999, Abb. 63, T. 19).

were inhumations.⁵⁷⁹ Another fragment of a composite helmet was reported for Grave Group V(50)/15 from Stična, though this origin is less credible, since Goldberg mentions a double-crested helmet in this grave.⁵⁸⁰ According to Božič, this brim fragment and another fragment from the Mecklenburg Collection of Vinica could have formed part of a helmet from Magdalenska gora (Preloge, Gr. IV/3), which is published without the brim.⁵⁸¹

DOUBLE-CRESTED HELMETS

The helmet that was offered by the Duchess to the German Emperor (*fig. 58*) and supposedly found in Grave VII/39 at Preloge,⁵⁸² differs from other double-crested examples in Dolenjska. Egg determined it as the south-eastern Alpine variant (*fig. 56: 4–9*).⁵⁸³ It shows certain older features: in the manner of attaching the brim to the skull it resembles the composite helmets from Brezje and Vače;⁵⁸⁴ the shape of its skull is reminiscent of a one-piece helmet from Populonia, dating to around 600 BC;⁵⁸⁵ while the horizontal decorative ribs on the skull are similar to those on the helmet from Býčí skála, which Parzinger, Trefný and Naso date to the first half of the sixth century BC and suppose it to be a derivative of models from Picenum.⁵⁸⁶ Based on a serpentine fibula, this time frame could also be ascribed to Grave VII/39 from Magdalenska gora, which would signify the grave group to be the earliest with this type of helmet in Dolenjska. The helmet type soon began to be produced in local workshops. This is indicated by another grave from Magdalenska gora (Preloge, Gr. 2/57), in which the helmet type was found together with two serpentine fibulae with wings. It reached its peak as part of the elite warrior outfit of the Certosa phase, when they could even be defined as a distinguishing

⁵⁷⁹ Gabrovec 1960b; *id.* 1965–1966; Egg 1986, Kat. Nr. 100, 104, 106, Abb. 112, 115: 1, 116, T. 45, 46a, 49a.

⁵⁸⁰ Gabrovec 1962–1963, 308, T. 9: 2; Wells 1981, 71, Fig. 125f; Egg 1986, 32, 167, Kat. Nr. 105, Abb. 115: 2, T. 49b; Teržan 2008, Abb. 32; Božič 2010, 167 ff, Abb. 13–15.

⁵⁸¹ Božič 2010, 167 ff, Abb. 11–13.

⁵⁸² Stična is also mentioned as the site of its provenance: Gabrovec 1962–1963, 307; Egg 1986, Kat. Nr. 129, T. 66.

⁵⁸³ Egg 1986, 35 ff, 173 ff, Kat. Nr. 118–138, Abb. 122–136, T. 56–70, 73a; Teržan 2008, 317 ff, Abb. 58, 59.

⁵⁸⁴ The examples of composite helmets show the brim attached to the exterior side of the skull with a row of rivets, bordered with a horizontal decorative rib on each side. The examples of double-crested helmets show the brim attached to the interior side of the skull and without any decoration on the brim. For comparison see Egg 1986, Abb. 112, 116, T. 45, 50, 66a, 73b.

⁵⁸⁵ Gabrovec 1962–1963, 307, 310, T. 20: 1; Egg 1986, 39 f, Kat. Nr. 139, T. 73b.

⁵⁸⁶ Parzinger *et al.* 1995, 59, T. 25: 290; Trefný 2002, 360 f, Abb. 1; Naso 2007, 27, Fig. 3.

ikonografski motiv v drugem frizu je moč brati kot napredovanje v hierarhiji (po Teržanovi) ali kot prenos oblasti (po Dularju in Turku).⁵⁸⁹

NEGOVSKE ČELADE

Problem kronologije in nosilcev čelad negovskega tipa je temeljito preučil Gabrovec, pri čemer se je v veliki meri oprl prav na grobne celote z Magdalenske gore.⁵⁹⁰ Njegovim tezam, kljub kritični presoji grobnih celot iz Mecklenburške zbirke, ni kaj oporekati. Najstarejša primerka negovskih čelad na jugovzhodnoalpskem prostoru sta najverjetneje tuje provenience in odražata že davno utrjene vezi s picensko-etrusčanskim svetom.⁵⁹¹ Gre za čelado s protomom v obliki levje glave (sl. 59), domnevno z Magdalenske gore, ki jo je Egg označil kot tip Volterra in okvirno datiral v čas druge polovice 6. ali na začetek 5. st. pr. n. št.⁵⁹² Drug tak italjski primerek je bil najden v grobu 48/104 iz Stične in pripada tipu Vetulonia, ki je nastal okoli leta 500.⁵⁹³ Iz njega naj bi se razvile negovske

⁵⁸⁹ Turk 2005, 36 s; Teržan 2007b; Dular/Tecco Hvala 2007, 247; Dular J. 2008, 431, op. 24.

⁵⁹⁰ Gabrovec 1965b.

⁵⁹¹ Glej še Egg 1986, 3 ss; Teržan 2008, 321 s, sl. 60, 61.

⁵⁹² Egg 1986, 48 ss, Kat. Nr. 168, T. 96.

⁵⁹³ *Ibid.*, 51 ss, Kat. Nr. 256, T. 178.



mark of the Dolenjska cavalry.⁵⁸⁷ The member of the Magdalenska gora community standing out in both wealth and insignia was buried in Grave 2/13 at Preloge, who might even have been chosen as the commander of the Dolenjska army. The originality of the Magdalenska gora community was expressed in the Certosa phase through a unique helmet, with a ribbed skull, buried with the deceased in Grave 13/55 at Preloge. Of its decoration, Teržan identified petals, a motif that might symbolize "safeguards for protection and strength."⁵⁸⁸ Symbolic meaning is also discernible on the bronze situla with figural decoration, offered to the deceased together with other valuable vessels; the iconographic motif in the second frieze could be read as advancement in the hierarchy (according to Teržan) or as transfer of power (according to Dular and Turk).⁵⁸⁹

NEGOVA HELMETS

The chronology and bearers of the Negova helmets were studied in depth by Gabrovec, whereby he relied heavily on the grave groups from Magdalenska gora.⁵⁹⁰ In spite of the fact that grave groups from the Mecklenburg Collection are not completely trustworthy, his hypotheses cannot be disputed. The earliest examples of Negova helmets in the south-eastern Alpine area are probably of foreign provenance, which reflects the long-established ties with the Picene and Etruscan worlds.⁵⁹¹ One of these items is the helmet with a lion's head protome (fig. 59), supposedly from Magdalenska gora, defined by Egg as Type Volterra and dated roughly into the second half of the sixth or the beginning of the fifth century BC.⁵⁹² The other Italic example was found in Grave 48/104 at Stična and belongs to Type Vetulonia, which appeared around 500 BC.⁵⁹³ Possibly developed from this type were the Negova helmets of the so-called Italo-Slovenian type as

⁵⁸⁷ Dobrnič, *Gr. 7/5*; Parzinger 1988–1989, 550, T. 7: 8; *Libna-Špiler Tum. 2/Gr. 1*: Guštin 1976, T. 1–3; *Novo mesto-Znančeve njive, Gr. 1/23*: Knez 1986, T. 6; *Stična, Gr. V(50)/15(?)*, *VI(55?)/30*: Wells 1981, 71, 80, Figs. 125, 160; Egg 1986, Abb. 15; Teržan 2008, 269, Abb. 32–34, 36; *Magdalenska gora-Preloge, Gr. 2/13, 2/38, 2/57, 13/119*, and maybe *Laščik, Gr. V/6–7–7a (?)*.

⁵⁸⁸ Teržan 2007b, 89.

⁵⁸⁹ Turk 2005, 36 f; Teržan 2007b; Dular/Tecco Hvala 2007, 247; Dular J. 2008, 431, n. 24.

⁵⁹⁰ Gabrovec 1965b.

⁵⁹¹ See also Egg 1986, 3 ff; Teržan 2008, 321 f, Abb. 60, 61.

⁵⁹² Egg 1986, 48 ff, Kat. Nr. 168, T. 96.

⁵⁹³ *Ibid.*, 51 ff, Kat. Nr. 256, T. 178.

Sl. 59: Negovska čelada iz zbirke kneza Windischgrätza, domnevno z Magdalenske gore (po Egg 1986, T. 96).

Fig 59: Negova Helmet in the Windischgrätz's collection, presumably from Magdalenska gora (after Egg 1986, T. 96).

čelade t. i. italsko-slovenskega tipa po Eggu, ki so zastopane z enim primerkom na Libni in dvema v depojski najdbi iz Ženjaka.⁵⁹⁴ Ta tip pa naj bi dozdevno služil za vzor izdelovalcem "slovenskih" oz. jugovzhodnoalpskih negovskih čelad, ki jih je Egg še bolj podrobno razčlenil. Največ "slovenskih" primerkov pripada njegovi različici Vače, časovno opredeljeni v drugo polovico 5. in zgodnje 4. st. pr. n. št. K tej različici med drugim prištevata obe ohranjeni negovski čeladi z Magdalenskogorske gore,⁵⁹⁵ pa tudi primerka z Vač in Ženjaka, ki imata puncirane in vrezane pismenke, ki še niso povsem pojasnjene. Sestavni deli napisa na čeladi tega tipa iz Ženjaka (*TUTNITANUATI* (?); *SIRAKUTUPRI•TARPTEISFU* (?); *PURAK*) so izpisani v treh različnih slogih.⁵⁹⁶ Na čeladi z Vač pa je v puncirani tehniki vtisnjeno ime *IERISNA*;⁵⁹⁷ isto ime se pojavlja na astragalih iz kulturnega mesta na Monte Ozol pri San Zenu in ga interpretirajo kot posvetilni napis.⁵⁹⁸ Pismenke so vrezane še na enem primerku negovske čelade iz Ženjaka, ki pripada italsko-slovenskemu tipu.⁵⁹⁹ Negovske čelade tako predstavljajo prve "pisne dokumente" na tem prostoru, kar pomeni velik civilizacijski korak, po drugi strani pa poslednje suverene dolenjske halštatske skupnosti. Na njihovih čeladah pritegnejo pozornost tudi poškodbe od udarcev z ostrim predmetom.⁶⁰⁰ Domnevno gre za ritualno poškodovanje, česar na starejših čeladah ni opaziti, pač pa zasledimo tovrstne poškodbe na ilirskem tipu čelad, ki se je v tistem času pojavil v središču ob Krki (Novo mesto-Kapiteljska njiva, gr. 7/19),⁶⁰¹ kar govori, da je v negovski stopnji prišlo do sprememb v grobnem ritualu.

Čelade upravičeno prištevamo med najprestižnejše kose, saj so z njimi povezane tako pomembne novosti, kot so likovna govorica v plitvem reliefu z antropomorfni upodobitvami,⁶⁰² mala bronasta plastika⁶⁰³ ter pisana beseda,⁶⁰⁴ s katerimi je prazgodovinska

⁵⁹⁴ *Ibid.*, 62 ss, Kat. Nr. 295–297, Abb. 174, 175, T. 208–211.

⁵⁹⁵ *Ibid.*, 66 ss, Kat. Nr. 298–331.

⁵⁹⁶ Istenič 1985, 327 s, sl. 4; Egg 1986, Kat. Nr. 324, Abb. 183, T. 243.

⁵⁹⁷ Istenič 1985, 326, sl. 3.

⁵⁹⁸ Sassatelli 1999, 458 s, Fig. 2–5.

⁵⁹⁹ Istenič 1985, 328, sl. 5; Egg 1986, Kat. Nr. 297, Abb. 175.

⁶⁰⁰ Teržan 1976, T. 29: 4, 24; Hencken 1978, Fig. 137, 138; Knez 1986, T. 31; Egg 1999, Abb. 4, 5.

⁶⁰¹ Križ 2004, Fig. 4, Kat. Nr. 7.10; Križ et al. 2009, 124; Egg 1999, Abb. 4, 5.

⁶⁰² Sestavljena čelada s figuralnim okrasom z Magdalenske gore: Gabrovec 1964–1965b.

⁶⁰³ Figurica bojevnika s skledasto čelado z Vač in druga z negovsko čelado iz Idrije pri Bači: Stare F. 1962–1963; Frey 1973, 626 s, Abb. 3: 1; Gabrovec 1987, 105, 107 s; Guštin 1980, sl. 1, T. 12; Egg 1986, 114, Abb. 53: 2.

⁶⁰⁴ Napisi na negovskih čeladah z Vač in Ženjaka: Istenič 1985.

defined by Egg, of which one example was found at Libna and two within the hoard find at Ženjak.⁵⁹⁴ The type presumably served as a model to the makers of the "Slovenian" or south-eastern Alpine Negova helmets, which Egg subdivided even further. Most of the "Slovenian" examples are of his Vače variant, dated to the second half of the fifth and early fourth century BC. The variant includes both preserved Negova helmets from Magdalenska gora,⁵⁹⁵ as well as the helmets from Vače and Ženjak with punched and incised letters that have not been entirely explained. The inscription on the helmet from Ženjak (*TUTNITANUATI* (?); *SIRAKUTUPRI•TARPTEISFU* (?); *PURAK*) is written in three different styles.⁵⁹⁶ The name *IERISNA* is punched onto the helmet from Vače,⁵⁹⁷ whereby the same name appears on astragali found at the cult place on Monte Ozol near San Zeno, interpreted as a dedicatory inscription.⁵⁹⁸ Letters are incised on another Negova helmet from Ženjak, this one of the Italo-Slovenian type.⁵⁹⁹ Negova helmets are thus the first "written documents" in the area, which represents a considerable step forward in civilization, but also the objects of the last sovereign Hallstatt community of Dolenjska. The helmets further draw attention for the damage caused by a sharp object.⁶⁰⁰ It is presumably ritual damage not noticeable on earlier helmets. It is also observed on the Illyrian-type helmets appearing in this period at Novo mesto along the Krka (Kapiteljska njiva, Gr. 7/19).⁶⁰¹ This indicates a change in the funerary ritual in the Negova phase.

Helmets are justifiably considered as one of the most prestigious objects, since they incorporate important novelties such as artistic language expressed through anthropomorphic depictions in low relief,⁶⁰² bronze statuettes⁶⁰³ and writing,⁶⁰⁴ with which a prehis-

⁵⁹⁴ *Ibid.*, 62 ff, Kat. Nr. 295–297, Abb. 174, 175, T. 208–211.

⁵⁹⁵ *Ibid.*, 66 ff, Kat. Nr. 298–331.

⁵⁹⁶ Istenič 1985, 327 f, Fig. 4; Egg 1986, Kat. Nr. 324, Abb. 183, T. 243.

⁵⁹⁷ Istenič 1985, 326, Fig. 3.

⁵⁹⁸ Sassatelli 1999, 458 f, Figs. 2–5.

⁵⁹⁹ Istenič 1985, 328, Fig. 5; Egg 1986, Kat. Nr. 297, Abb. 175.

⁶⁰⁰ Teržan 1976, T. 29: 4, 24; Hencken 1978, Figs. 137, 138; Knez 1986, T. 31; Egg 1999, Abb. 4, 5.

⁶⁰¹ Križ 2004, Fig. 4, Kat. Nr. 7.10; Križ et al. 2009, 124; Egg 1999, Abb. 4, 5.

⁶⁰² A composite helmet with figural decoration from Magdalenska gora: Gabrovec 1964–1965b.

⁶⁰³ A bronze statuette of a warrior with a bowl-shaped helmet from Vače and another one with a Negova helmet from Idrija pri Bači: Stare F. 1962–1963; Frey 1973, 626 f, Abb. 3: 1; Gabrovec 1987, 105, 107 f; Guštin 1980, Fig. 1, T. 12; Egg 1986, 114, Abb. 53: 2.

⁶⁰⁴ Inscriptions on Negova helmets from Vače and Ženjak: Istenič 1985.

Najdišče Site	Tipi čelad / Types of helmets								Skupaj Total
	Stožčasta Conical	Skledasta Bowl-shaped	Koničasta Ogival	Sestavljena Composite	Dvogrebenasta Double-crested	13/55	Negovska Negova	Ilirska Illyrian	
Magdalenska gora	1			2+?	7	1	4+?		15+?
Stična		4-5	1	?	5		4		15
Vače		3		1	3		2		9
Veliki Vinji vrh (Šmarjeta)		8			1				9
Novo mesto		1		1	1		2	2	7
Libna		1		1	1		1		4
Brezje		2		1			1		4
Dolenjske Toplice							2		2
Budinjak		2							2
Molnik		1							1
Velike Malence		1							1
Rovišče		1							1
Dobrnič					1				1
Vinkov vrh					1				1
Valična vas							1+2?		1+?
Selo nad Gor. Vrhpoljem	1								1
Skupaj / Total	2	25	1	6	20	1	17	2	74

Sl. 60: Številčno razmerje med posameznimi tipi čelad v dolenski skupnosti (po Teržan 2008, sl. 36 in seznamih k sl. 55, 57, 59, 61).

Fig. 60: Quantitative ratio of individual helmet types in the Dolenjska community (after Teržan 2008, Abb. 36 and lists to Abb. 55, 57, 59, 61).

skupnost poskušala ujeti korak z razvitimi kulturami antičnega sveta.

V starejšem halštatskem obdobju bi magdalenskogorski skupnosti sodeč po številu čelad ne mogli prisoditi vidnejše vloge. Po drugi strani pa so na tem najdišču zastopani prav tisti tipi čelad (stožčasta in sestavljena), ki v dolenskem halštatskem krogu niso bili "domači" (sl. 60). Toda bilo bi preveč tvegano reči, da so ji vladali tujci, ki so prišli z namenom, da zaščitijo svoje trgovske interese in nadzorujejo blagovne tokove na dolge razdalje, čeprav bi za to domnevo govoril tudi najstarejši primerek dvogrebenaste čelade, ki se po eni strani navezuje na italške vzore, na drugi strani pa ga družijo skupne prvine s čelado iz Býčí skále na Moravskem. Če bi bilo možno dokazati, da je bila negovska čelada tipa Volterra iz Windischgrätzove zbirke dejansko najdena na Magdalenski gori, bi to pomenilo njen primat tudi pri uveljavljanju negovskih čelad. Prav tako je še nepojasnjena uganka s fragmentirano čelado z vtisnjanim napisom z Magdalenske gore, ki jo hrani privatni muzej v Logatcu. Tako in drugače se je Magdalenska gora v mladohalštatskem času povzpela v sam vrh med dolenskiimi središči, kar pričata med drugim število dvogrebenastih čelad in svojevrstni izdelek z narebreno kaloto (Preloge, gr 13/55). Da je ohranila vidno mesto še v negovski stopnji, ne govori le število čelad negovskega

toric community tried to keep abreast of the developed cultures of the Classical world.

Finds of helmets show that the Magdalenska gora community did not play a more prominent role in the Early Hallstatt period. On the other hand, the helmet types represented at the site (conical and composite) are "foreign" within the Dolenjska Hallstatt circle (fig. 60). Based on this, it would be too bold to suppose the community being governed by foreigners who came here with the intention of protecting their commercial interests and controlling long-distance trading. Such a supposition, however, would be supported by the earliest double-crested helmet tied to the Italic models and showing common traits with the helmet from Býčí skála in Moravia. If it were possible to prove that the Volterra type helmet from the Windischgrätz Collection really was found at Magdalenska gora, it would signify the site's primacy also in the introduction of the Negova helmets. Also unexplained is the fragmented helmet with an impressed inscription from Magdalenska gora kept in the Logatec War Museum. In the Late Hallstatt period, Magdalenska gora figured among the most prominent centres of Dolenjska, which is discernible from many aspects and, of course, also from the helmets. This is also evidenced by the number of double-crested helmets and a unique helmet with a ribbed skull (Preloge, Gr.

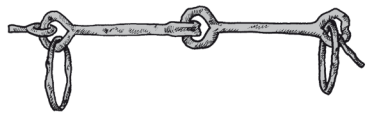

1



3



4



9

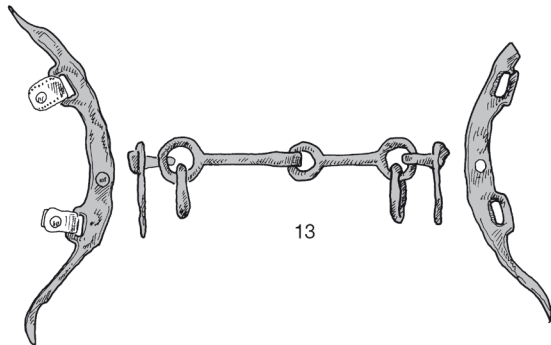

13

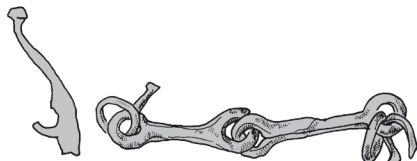

14

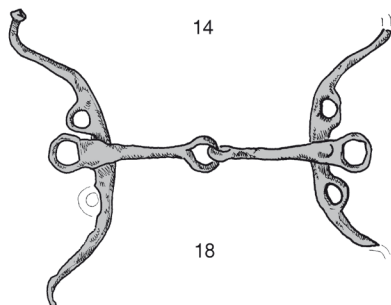

18

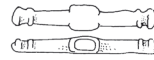

2



5



7



10



11

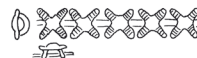

15

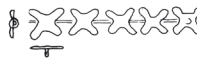

17

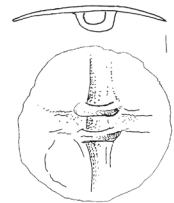

12

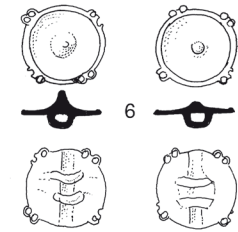

6

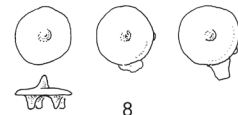

8

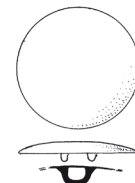

16



19

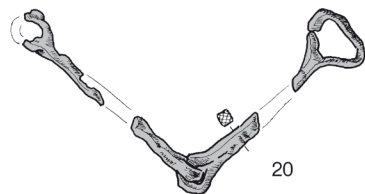

20



21



22



23

tipa, temveč tudi količina drugega orožja, zlasti pa prvi primerki latenskih mečev in dozdevno edinstven pokop s štirimi konji na Dolenjskem.

4.3 KONJSKA OPREMA, OSTROGE IN DEREZE

O tem, kakšne konje so jezdili magdalenskogorski konjeniki, je tekla beseda v začetnih poglavjih.⁶⁰⁵ Gre za iskre konje vzhodne skupine po Bökönyju, ki so jih morebiti dobavljali iz Panonije, za kar bi govorile tudi brzde, ki večidel pripadajo tipu Szentes-Vekerzug (*sl. 61: 3, 9, 13, 14, 18*), toda ne vse.

4.3.1 KONJSKE BRZDE IN JERMENSKO OKRASJE

V okviru izkopavanj vojvodinje Mecklenburške so našli na več konjskih pokopov z opremo.⁶⁰⁶ Štiri take grobove so zabeležili v gomili IV na Prelogah. V grobu IV/30, ki ga je Goldberg označil kot Konjski grob I, so zabeleženi košček brzd z delno ohranjeno stranico ter dva niza okroglih dvojnih diskov (*sl. 61: 3, 4*). Podatkov o konjskih kosteh sicer ni, je pa bilo analizirano človeško okostje iz tega groba, v katerem je Angel prepoznal starca z mešanimi alpskimi potezami.⁶⁰⁷ V t. i. Konjskem grobu II (= IV/32) so našli slabo ohranjene konjske kosti, bronast okov trikotne oblike ter bronast kotliček; med prdatki konjenika pa Goldberg navaja situlo, čelado, pasno spono, dve fibuli z diski ter sulično ost, nož in okrašeno koščeno platišče. Morebiti je temu grobu pripadalo človeško okostje (IV/II), ki ga je Angel opredelil kot odraslega mladega moškega alpskega tipa.⁶⁰⁸ Pridatki Konjskega groba III (= IV/40) niso znani. Konjski grob IV (= IV/43) pa bi naj vseboval ostanke jermenja, sekira in dve glinasti posodi. V objavljeni grobni sestavi so vključene najdbe iz Peabodyjevega muzeja in Narodnega muzeja v Ljubljani, med njimi pa nastopajo koščki brzd, falere in okrasni gumbi (*sl. 61: 5, 6*). V okviru zgodnejših izkopavanj vojvodinje Mecklenburške na Prelogah sta bili v gomili II najdeni dve konjski brzdi, od katerih je

⁶⁰⁵ Glej poglavje 1.1.3 o analizi kostnih ostankov, *sl. 3* ter poglavje 3.2.4 o živalskih ostankih v grobnem kultu, *sl. 36*.

⁶⁰⁶ Hencken 1978, Fig. 29, 69a,i, 84f, 85b,e,f,l,m, 86: f-k, 108, 109d, 112j, 135, 144a-c, 146, 148a-c, 149a,b.

⁶⁰⁷ Angel 1968, 95.

⁶⁰⁸ *Ibid.*, 97. Glej tu poglavje 1.1.3, *sl. 6*.

13/55). The number of Negova helmets, the quantity of other weapons, particularly Early La Tène swords, as well as the burial with four horses supposedly unique in Dolenjska all show that it maintained its high position into the Negova phase.

4.3 HORSE GEAR, SPURS AND CRAMPONS

As written in the introductory chapters, the horse-men of Magdalenska gora rode fast horses of the eastern group as defined by Bökönyi.⁶⁰⁵ They may have been imported from Pannonia, which could be substantiated by the bridle-bits that predominantly belong to Type Szentes-Vekerzug (*fig. 61: 3, 9, 13, 14, 18*).

4.3.1 BRIDLE-BITS AND STRAP DECORATION

Several horse burials with horse gear came to light during the excavations by the Duchess of Mecklenburg.⁶⁰⁶ Four such graves were found in Tumulus IV at Preloge. Grave IV/30, containing a fragment of a bridle-bit with a partly preserved cheek-piece and two sets of double discs (*fig. 61: 3, 4*), was marked by Goldberg as Horse Grave I. There is no mention of horse bones, while the human skeleton was determined by Angel as belonging to an old man with mixed Alpine traits.⁶⁰⁷ The so-called Horse Grave II (= IV/32) revealed poorly preserved horse bones, a bronze triangular fitting and a bronze cauldron, while as goods of the horseman Goldberg lists a situla, helmet, belt clasp, two fibulae with discs and a spearhead, a knife and a decorated bone mount. This grave may have contained the human skeleton (IV/II) identified by Angel as an adult male of the Alpine type.⁶⁰⁸ The goods in Horse Grave III (= IV/40) are not known. Horse Grave IV (= IV/43) reportedly contained the remains of straps, an axe and two clay vessels, while the grave group divided between the Peabody Museum and the National Museum in Ljubljana consists of bridle-bit fragments, phalerae and

⁶⁰⁵ See Chapter 1.1.3 on horse bone analysis, *fig. 3*, and Chapter 3.2.4 on animal remains in the grave cult, *fig. 36*.

⁶⁰⁶ Hencken 1978, Figs. 29, 69a,i, 84f, 85b,e,f,l,m, 86: f-k, 108, 109d, 112j, 135, 144a-c, 146, 148a-c, 149a,b.

⁶⁰⁷ Angel 1968, 95.

⁶⁰⁸ *Ibid.*, 97. See also Chapter 1.1.3, *fig. 6*.

Sl. 61: Konjska oprema z Magdalenske gore. 1, 3, 7, 13, 14, 18–20 = železo; 21–23 = svinec; ostalo = bron. M. = 1:4.

Fig. 61: Horse gear from Magdalenska gora. 1, 3, 7, 13, 14, 18–20 = iron; 21–23 = lead; other = bronze. Scale = 1:4.

1 – Preloge, gr. VII/39; 2 – Preloge, gr. 13/95; 3, 4 – Preloge, gr. IV/30; 5, 6 – Preloge, gr. IV/43; 7, 8 – Preloge, gr. 2/57; 9–12 – Preloge, gr. 2/13; 13–17 – Laščik, gr. V/29; 18 – Preloge, gr. II/19a; 19 – Preloge, gr. V/26a; 20 – Preloge, gr. 2/j; 21 – Laščik, gr. V/31; 22 – Preloge, gr. 2/38; 23 – Preloge, gr. IV/16.

objavljen le primerek iz groba II/19a (*sl. 61: 18*), medtem ko je brzda iz groba II/6 pogrešana. Brzdo so našli še v gomili VII na Prelogah, v grobu 39 (*sl. 61: 1*), kjer je ležala ob konjski čeljusti, medtem ko so konjeniku pripadali dvogrebenasta čelada, kačasta fibula, pravokotna pasna spona in orožje (*sl. 37: 5 in sl. 58*).

Pravcato odkritje je vojvodinjo čakalo v gomili V na Laščiku, kjer so naleteli na skupni grob dveh konjenikov s štirimi konji (V/29). Zraven konjskih okostij sta ležala dva kotliča, v bližini pa sedem okroglih faler z dvema zankama na spodnji strani, okoli devetdeset križnih gumbkov in železna brzda (*sl. 61: 13, 15, 16*). V sklopu te grobne celote je objavljenih še šest manjših okroglih faler z dvema zankama in ena brzda (*sl. 61: 14, 17*), ki jih hrani Narodni muzej v Ljubljani. Na južni strani te gomile so naleteli na poškodovan grob (V/5), ki naj bi poleg konjskih kosti in zob vseboval tudi konjsko brzdo, vendar je ta pogrešana. Pogrešana je tudi brzda iz groba V/6–7–7a, o katerem obstaja fotografija, na kateri je viden dobro ohranjen konjski skelet, ob lobanji pa okrogle falere z dvojno zanko (*sl. 4*); zraven so bili še kotliček, pri zadnjih okončinah pa dve samostrelni fibuli z verižico. Po Goldbergovih navedbah naj bi bil en križni gumb najden tudi pri pokojniku v tem grobu, ki je med drugim menda imel dvogrebenasto čelado. Manjkajo torej tri brzde (Laščik, gr. V/5, V/6–7–7a; Preloge, gr. II/6), v grobu V/29 pa je ena dozdevno odveč. Odveč je tudi miniaturna brzda, objavljena v sklopu grobne celote V/26a, ki jo hrani Narodni muzej v Ljubljani (*sl. 61: 19*). Goldberg je v opisu tega groba ne omenja, pač pa navaja, da je bil ta grob podaljšek groba V/6–7–7a, kjer brzda manjka.

Nekaj grobov s konjsko opremo je odkril tudi Pečnik v gomilah 2 in 13 na Prelogah.⁶⁰⁹ V žarnem grobu 13/95 je bil najden bronast zatič (*sl. 61: 2*), ki je domnevno pripadal konjski opremi. Med pridatke v žari so spadali še železen nož, ostanki sežgane bronaste situle ter kačasti fibuli s kolesčki oz. rozetami, ki sta izgubljeni. To je tudi edini žgani pokop s konjsko opremo na Magdalenski gori. V tej gomili so v sklopu groba 13/119 odkrili konjsko okostje brez opreme. Nekaj primerkov konjske opreme so zabeležili še v gomili 2. Grobna celota 2/j, v kateri nastopa železna brzda (*sl. 61: 20*), je le delno rekonstruirana, od drugih pridatkov se omenjajo bronast kotliček, dve fibuli, dve svinčeni zapestnici, pas iz bronašte pločevine, okovi, dve sulični osti, uhata sekira in nož. Od konjske opreme v grobu 2/57 so ohranjeni le delčki brzd in okrasje za vajeti v obliki drobnih razčlenjenih gumbkov ter okrogli razdelilni gumbi t. i. trakokimerijskega tipa (*sl. 61: 7, 8*), lastnik konja pa je bil opremljen z dvogrebenasto čelado, kačastima fibulama s krilci, pasnima sponama in orožjem (*sl. 54*). Najbogatejša konjska oprava je znana iz groba 2/13, ki jo sestavljajo brzda z usločenima stranicama, pet velikih okroglih

⁶⁰⁹ Tecco Hvala/Dular/Kocuvan 2004, T. 14A: 31–35, 27: 32–43, 52: 10–21, 97B: 1.

decorative buttons (*fig. 61: 5, 6*). Earlier excavation of the Duchess at Preloge included work on Tumulus II, which revealed two horse bridle-bits. Of those, only the bridle-bit from Grave II/19a (*fig. 61: 18*) has been preserved, while the one from Grave II/6 is missing. A bridle-bit was also found lying beside a horse's jaw bone in Tumulus VII at Preloge, in Grave 39 (*fig. 61: 1*); while the outfit of the horseman consisted of a double-crested helmet, a serpentine fibula, a rectangular belt clasp and weapons (*fig. 37: 5 and fig. 58*).

A remarkable discovery awaited the Duchess in Tumulus V at Laščik, where a burial of two horsemen with four horses (V/29) was found, with a pair of bronze cauldrons beside them. In the vicinity, seven round phalerae with two loops on the lower side, roughly ninety cruciform buttons and an iron bridle-bit (*fig. 61: 13, 15, 16*). Published as goods from this grave are also six small round phalerae with two loops and another bridle-bit (*fig. 61: 14, 17*), kept in the National Museum in Ljubljana. The southern side of the tumulus revealed a damaged grave (V/5), which reportedly contained horse bones and teeth as well as a bridle-bit, though the latter is missing. Also missing is the bridle-bit from Grave V/6–7–7a; a photograph was taken of this grave, which clearly shows a horse's skeleton with round phalerae with two loops beside the skull (*fig. 4*). Grave goods further include a bronze cauldron and two crossbow fibulae tied with a chain beside the hind legs. According to Goldberg, one cruciform button was found beside the horseman in this grave, whose goods further included reportedly a double-crested helmet. Missing from the preserved material are three bridle-bits (Laščik, Gr. V/5, V/6–7–7a; Preloge, Gr. II/6), while one is apparently superfluous in Grave V/29. Also superfluous is the miniature bridle-bit published as part of Grave V/26a, kept in the National Museum in Ljubljana (*fig. 61: 19*). There is no mention of it in Goldberg's description of the grave, he does state, however, that the grave was situated in the extension of Grave V/6–7–7a, where a bridle-bit is missing.

Several graves with horse gear were also excavated by Pečnik in Tumuli 2 and 13 at Preloge.⁶⁰⁹ The urn Grave 13/95 revealed a bronze toggle (*fig. 61: 2*), which might have formed part of horse gear, an iron knife, burnt remains of a bronze situla and two serpentine fibulae with wheels or rosettes, the latter now lost. This would represent the only cremation burial with horse gear at Magdalenska gora. Grave 13/119 revealed a horse's skeleton without any trappings. Grave Group 2/j, which includes an iron bridle-bit (*fig. 61: 20*), is only partly reconstructed, with other mentioned goods being a bronze cauldron, two fibulae, two lead bracelets, belt of sheet bronze, fittings, two spearheads, a shaft-hole axe and a knife. Of the horse gear in Grave 2/57 only pieces of the bridle-bit, rein decorations in the form of small

⁶⁰⁹ Tecco Hvala/Dular/Kocuvan 2004, T. 14A: 31–35, 27: 32–43, 52: 10–21, 97B: 1.

faler z dvema zankama na spodnji strani, okrogli dvojni diski ter bronasti okrasni gumbki S-oblike in v obliki živalskih glav (sl. 61: 9–12). Prestižno opravo je imel tudi konjenik, pokopan v tem grobu, ki je med drugim posedoval dvogrebenasto čelado, žezlo in dereze (sl. 54).

Razširjenost in časovni okvir. Kot najstarejši kos konjske opreme na tem najdišču bi lahko opredelili bronast zatič (sl. 61: 2), ki ga funkcionalno povezujejo z brzdami; rekonstrukcijo možne rabe je predložil Dobiat.⁶¹⁰ Taki zatiči se pojavljajo od južne Nemčije in Češke do južnega obrobja Alp in severozahodne Panonije, večina primerkov s severnih najdišč pa sodi v čas Ha C.⁶¹¹ Iz tega časa, tj. iz stopnje Stična 2, je tudi zatič z Magdalenske gore, medtem ko primerka iz Brezja in Volčjih Njiv spadata v certoško stopnjo.⁶¹² Podobni zatiči so zabeleženi še na Vačah in v okolici Velikega Vinjega vrha (Šmarjeta), toda brez ohranjenih grobnih celot.⁶¹³

Železna dvodelna brzda iz magdalenskogorskega groba VII/39 s Prelog (sl. 61: 1) se uvršča med primerke, ki imajo namesto stranic gibljive obroče za vajeti.⁶¹⁴ Gre za enostavno obliko brzd, ki se je razmahnila v času poznega Ha C in zgodnjega Ha D na širokem območju od zahodne Panonije do južne Nemčije in Padske nižine.⁶¹⁵ Na območju dolenske halštatske skupnosti jih zasledimo že v stopnji Podzemelj 2, kot priča grob 1/16 s Kapiteljske njive v Novem mestu,⁶¹⁶ medtem ko je magdalenskogorski grob VII/39 vodilni predstavnik stopnje kačastih fibul. Zastopane so še na Vačah,⁶¹⁷ v Stični,⁶¹⁸ na Velikem Vinjem vrhu oz. Šmarjeti⁶¹⁹ in v Zagorju,⁶²⁰ vendar ne v okviru grobnih celot, srečamo pa jih tudi na Notranjskem (Trnovo, Tržišče).⁶²¹

Drugo vrsto predstavljajo dvodelne brzde s fiksno pritrjenimi stranicami, kamor spada največ magdalenskogorskih primerkov (sl. 61: 3, 9, 13, 18). Tovrstne brzde pripadajo tipu Szentes-Vekerzug po Parduczu, ki jih je glede na različno ukrivljenost stranic ločil v pet različic, h katerim sta Guštin in Teržanova dodala

⁶¹⁰ Dobiat 1979, Abb. 1, T. 20: 4. Njegov seznam zbranih primerkov je doživel kasneje nekaj korektur in dopolnitev: Parzinger/Nekvasil/Barth 1995, 71; dopolnjeno karto po Dobiatu in Pare je nazadnje objavil Egg 1996, 183 ss, Abb. 91.

⁶¹¹ Egg 1996, 183 s.

⁶¹² *Brezje, gr. 7/1*: Kromer 1959a, T. 20: 1; *Volčje Njive, gr. 21*: Gabrovec 1956, T. 19: 10; Teržan 1976, sl. 54: 39.

⁶¹³ Stare V. 1973a, T. 24: 14,15; Dobiat 1979, T. 20: 5 (NHMW inv. št. 7609).

⁶¹⁴ Hencken 1978, Fig. 259b; Werner 1988, 110, T. 61: 371.

⁶¹⁵ Teržan 1990a, 82, 103.

⁶¹⁶ Knez 1993, T. 17: 6.

⁶¹⁷ Stare F. 1955a, T. 17: 1.

⁶¹⁸ Wells 1981, Fig. 149e, 159a; Gabrovec et al. 2006, T. 148: 28.

⁶¹⁹ Stare V. 1973a, T. 8: 13; Dular A. 1991, T. 19: 6.

⁶²⁰ Gabrovec 1966b, T. 6: 1,3.

⁶²¹ Guštin 1979, T. 12: 2,3, 30: 3–9.

knobbed buttons and phalerae of the so-called Thracio-Cimmerian type are preserved (fig. 61: 7, 8), while the horseman had a double-crested helmet, two serpentine fibulae with wings, two belt clasps and weapons (fig. 54). The richest horse gear was found in Grave 2/13, composed of a bridle-bit with curved cheek-pieces, five large round phalerae with two loops on the lower side, round double discs and small decorative bronze buttons, the latter S-shaped and in the shape of animal heads (fig. 61: 9–12). An outfit of prestige was also found with the horseman buried in this grave, which included a double-crested helmet, mace and crampons (fig. 54).

Distribution and time frame. The earliest piece of horse gear at Magdalenska gora might be seen in the bronze toggle (fig. 61: 2), which is functionally tied to the bridle-bit. A reconstruction of its use was proposed by Dobiat.⁶¹⁰ Such toggles were found from southern Germany, the Czech Republic to the southern fringes of the Alps and north-western Pannonia. Most examples of the West Hallstatt circle date to Ha C.⁶¹¹ In Dolenska, the toggle from Magdalenska gora dates to the Stična 2 phase, while two examples from Brezje and Volčje Njive date to the Certosa phase.⁶¹² Similar toggles were also found at Vače and Veliki Vinji vrh (Šmarjeta), though without preserved grave groups.⁶¹³

The iron two-piece bridle-bit from Grave VII/39 at Preloge (fig. 61: 1) is of the type with movable side rings, rather than cheek-pieces for attachment to the reins.⁶¹⁴ It is a simple form that became commonly used in late Ha C and early Ha D across a wide area from western Pannonia to southern Germany and the Po Plain.⁶¹⁵ In the territory of the Dolenska Hallstatt community, they can be traced to the Podzemelj 2 phase, as evidenced by Grave 1/16 at Kapiteljska njiva in Novo mesto.⁶¹⁶ Another one was found in Grave VII/39 from Magdalenska gora, which is a leading representative of the Serpentine Fibulae phase. Further examples were found at Vače,⁶¹⁷ Stična,⁶¹⁸ Veliki Vinji vrh (Šmarjeta)⁶¹⁹ and Zagorje,⁶²⁰

⁶¹⁰ Dobiat 1979, Abb. 1, T. 20: 4. His list was later supplemented and corrected by Parzinger/Nekvasil/Barth 1995, 71; Egg 1996, 183 ff, Abb. 91.

⁶¹¹ Egg 1996, 183 f.

⁶¹² *Brezje, Gr. 7/1*: Kromer 1959a, T. 20: 1; *Volčje Njive, Gr. 21*: Gabrovec 1956, T. 19: 10; Teržan 1976, Abb. 54: 39.

⁶¹³ Stare V. 1973a, T. 24: 14,15; Dobiat 1979, T. 20: 5 (NHMW Inv. No. 7609).

⁶¹⁴ Hencken 1978, Fig. 259b; Werner 1988, 110, T. 61: 371.

⁶¹⁵ Teržan 1990a, 82, 103.

⁶¹⁶ Knez 1993, T. 17: 6.

⁶¹⁷ Stare F. 1955a, T. 17: 1.

⁶¹⁸ Wells 1981, Figs. 149e, 159a; Gabrovec et al. 2006, T. 148: 28.

⁶¹⁹ Stare V. 1973a, T. 8: 13; Dular A. 1991, T. 19: 6.

⁶²⁰ Gabrovec 1966b, T. 6: 1,3.

še šesto.⁶²² Svojo tipologijo brzd je pozneje predložil Werner;⁶²³ po njegovi klasifikaciji pripada primerek iz magdalenskogorskega groba 2/13 s Prelog (sl. 61: 9) različici IIA1 (= varianti 2 in 3 po Parducz),⁶²⁴ medtem ko primerki iz groba IV/30 zaradi fragmentiranosti ni podrobneje določljivi (sl. 61: 3).⁶²⁵ Na Dolenjskem je ta različica znana še iz Brezja, Libne, Novega mesta, Vač in Zagorja,⁶²⁶ pojavlja se tudi na severnem obrobju Panonije in na Slovaškem.⁶²⁷

Brzdo iz magdalenskogorskega groba II/19a s Prelog (sl. 61: 18) je Werner opredelil kot različico IIA2 (= varianta 6 po Guštinu in Teržanovi),⁶²⁸ kamor je uvrstil tudi primerke z Velikega Vinjega vrha (Šmarjeta)⁶²⁹ in Novega mesta.⁶³⁰ Dozdevno gre za lokalne posnetke t. i. skitskih žval, saj so za zdaj poznane le na Dolenjskem, kjer se pojavljajo v zgodnji negovski stopnji.⁶³¹ Domače izdelave je verjetno tudi brzda iz magdalenskogorskega groba V/29 z Laščika (sl. 61: 13), ki prav tako sodi v zgodnjo negovsko stopnjo in nima neposrednih primerjav.⁶³² Ostanke brzd iz grobov 2/j, 2/57, IV/43 s Prelog ter V/26a z Laščika (sl. 61: 19, 20) pa tipološko niso določljivi.⁶³³

H konjski opremi so razen brzd spadale tudi falere in okrasni gumbki za jermenje. V sklopu groba IV/43 s Prelog so objavljene tutulaste falere z ušesci ob robu ter dvema zankama na spodnji strani (sl. 61: 6),⁶³⁴ ki jim lahko sledimo vse do Severnega oz. Baltiškega morja, v severozahodno Panonijo in na drugi strani v Verucchio in Etrurijo, največja koncentracija pa je opazna na območju južne Nemčije.⁶³⁵

⁶²² Parducz 1973, 36, Karte 3; Guštin/Teržan 1975, 190 s, karta 1.

⁶²³ Werner 1988, 12 ss, Abb. 4.

⁶²⁴ *Ibid.*, 15 s, T. 3: 14; Tecco Hvala/Dular/Kocuvan 2004, T. 27: 44.

⁶²⁵ Hencken 1978, 69i.

⁶²⁶ *Brezje, gr. 6/1*: Kromer 1959a, T. 17: 5; *Libna, Špilerjeva gom. II/gr. 1*: Guštin 1976, T. 3: 1-3; *Novo mesto, Malenškova gom./gr. 3*: Guštin/Teržan 1975, T. 4: 2; *Vače*: Werner 1988, 16, T. 4: 22; *Zagorje*: Gabrovec 1966b, T. 6: 1.

⁶²⁷ Werner 1988, T. 68A.

⁶²⁸ *Ibid.*, 16 s, T. 5: 24.

⁶²⁹ Stare V. 1973a, T. 11: 7.

⁶³⁰ *Znančeve njive, gr. 4/3*; *Kapiteljska njiva, gr. 3/12, 7/19*: Knez 1986, T. 34: 10; Križ 1997, 37: 2; Egg 1999, Abb. 10: 1.

⁶³¹ Guštin/Teržan 1975, 190 s, karta 1; Werner 1988, 16 s, T. 5, 68A.

⁶³² Hencken 1978, Fig. 146.

⁶³³ Hencken 1978, Fig. 86f-k, 131f; Tecco Hvala/Dular/Kocuvan 2004, T. 14: 31-35, 52: 17-21.

⁶³⁴ Hencken 1978, Fig. 85e,f,l,m.

⁶³⁵ Kossack 1954b, 116 ss, 161, Karte 3: C, Abb. 1, 15: 7, 8, 20B: 2, 21C: 9, 23A: 6, 24A: 14, 26B: 5; Guidi 1983, 27 s, 81: B3, T. 1:10, 26:B; Metzner-Nebelsick 1996, 295 s, Abb. 8; *Verucchio*: Gentili 2003, T. 63: 16, 79: 25, T. CXVIII: 16, CLIV: 25; *Tarquīnia*: Hencken 1968a, 575, Fig. 186j; Teržan 1995b, 92 s.

though not within grave groups. Some also came to light in Notranjska (Trnovo, Tržišče).⁶²¹

The other type of bridle-bit has fixed cheek-pieces. Most of the examples from Magdalenska gora belong to this type; whereby the cheek-pieces here have a pair of loops and spherical terminals (fig. 61: 3, 9, 13, 18). Such bridle-bits belong to Type Szentes-Vekerzug as defined by Parducz, who distinguished between five variants on the basis of the difference in the curve. Guštin and Teržan added the sixth variant.⁶²² A bridle-bit typology was later also proposed by Werner;⁶²³ according to whom the example from Grave 2/13 at Preloge (fig. 61: 9) belongs to Variant IIA1 (= Variants 2 and 3 after Parducz),⁶²⁴ while the bridle-bit from Grave IV/30 is not determinable due to poor preservation (fig. 61: 3).⁶²⁵ Variant IIA1 bridle-bits in Dolenjska were also found at Brezje, Libna, Novo mesto, Vače and Zagorje.⁶²⁶ Outside Dolenjska, they are attested to on the northern fringes of Pannonia and in Slovakia.⁶²⁷

Werner determined the bridle-bit from Grave II/19a at Preloge (fig. 61: 18) as Variant IIA2 (= Variant 6 after Guštin and Teržan),⁶²⁸ which further includes bridle-bits from Veliki Vinji vrh (Šmarjeta)⁶²⁹ and Novo mesto.⁶³⁰ They presumably represent local imitations of the so-called Scythian bit mouth-pieces, since they are thus far known only in Dolenjska, where they appear in the early Negova phase.⁶³¹ The bridle-bit without direct analogies from Grave V/29 at Laščik (fig. 61: 13) was probably also made locally and dates to the early Negova phase.⁶³² The remains of bridle-bits from Graves 2/j, 2/57, IV/43 at Preloge and Grave V/26a at Laščik (fig. 61: 19, 20) are typologically undeterminable.⁶³³

Horse gear further included phalerae and decorative strap buttons. Published as part of Grave IV/43 at Preloge are tutulus-shaped phalerae with ears along the rim and two loops on the lower side (fig. 61: 6),⁶³⁴

⁶²¹ Guštin 1979, T. 12: 2,3, 30: 3-9.

⁶²² Parducz 1973, 36, Karte 3; Guštin/Teržan 1975, 190 f, Karte 1.

⁶²³ Werner 1988, 12 ff, Abb. 4.

⁶²⁴ *Ibid.*, 15 f, T. 3: 14; Tecco Hvala/Dular/Kocuvan 2004, T. 27: 44.

⁶²⁵ Hencken 1978, 69i.

⁶²⁶ *Brezje, Gr. 6/1*: Kromer 1959a, T. 17: 5; *Libna-Špiler Tum. II/Gr. 1*: Guštin 1976, T. 3: 1-3; *Novo mesto-Malenšek Tum./Gr. 3*: Guštin/Teržan 1975, T. 4: 2; *Vače*: Werner 1988, 16, T. 4: 22; *Zagorje*: Gabrovec 1966b, T. 6: 1.

⁶²⁷ Werner 1988, T. 68A.

⁶²⁸ *Ibid.*, 16 f, T. 5: 24.

⁶²⁹ Stare V. 1973a, T. 11: 7.

⁶³⁰ *Znančeve njive, Gr. 4/3*; *Kapiteljska njiva, Gr. 3/12, 7/19*: Knez 1986, T. 34: 10; Križ 1997, 37: 2; Egg 1999, Abb. 10: 1.

⁶³¹ Guštin/Teržan 1975, 190 f, Karte 1; Werner 1988, 16 f, T. 5, 68A.

⁶³² Hencken 1978, Fig. 146.

⁶³³ Hencken 1978, Figs. 86f-k, 131f; Tecco Hvala/Dular/Kocuvan 2004, T. 14: 31-35, 52: 17-21.

⁶³⁴ Hencken 1978, Fig. 85e,f,l,m.

V magdalenskogorski grobni celoti IV/43 nastopajo še dvoglavi okrasni gumbki z eno zanko na spodnji strani (sl. 61: 5).⁶³⁶ Najstarejši taki gumbki so znani v trakokimerijskem okolju v depoju Holih rady,⁶³⁷ na drugi strani se pojavljajo v južni Nemčiji v grobovih iz časa Ha C in D1.⁶³⁸ Na Dolenjskem so izpričani v Stični,⁶³⁹ na Velikem Vinjem vrhu (Šmarjeti)⁶⁴⁰ ter v grobu 2/57 s Prelog na Magdalenski gori, ki ga lahko datiramo v čas stopnje kačastih fibul; v slednjem so bili najdeni tudi taki troglavi gumbki (sl. 61: 7).⁶⁴¹ Iz Mecklenburške zbirke so objavljeni posamični primerki še v sklopu poznolatskega ženskega groba X/78 s Prelog na Magdalenski gori⁶⁴² ter med najdbami iz gomil v Stični.⁶⁴³ Podobno razčlenjeni okrasni gumbki se pojavljajo v Etruriji (Volterra) in na Bavarskem (Burggriesbach), kjer so datirani na prehod iz 7. v 6. st. pr. n. št.,⁶⁴⁴ pa tudi ob srednjem Donu v t. i. skitskem obdobju.⁶⁴⁵

V kombinaciji s t. i. skitskimi uzdami pogosto nastopajo večje in manjše okrogle falere z dvema zankama na spodnji strani (sl. 61: 12, 16, 17), ki jih je Parzinger označil kot tip Magdalenska gora. V dolenjski skupnosti, kjer so najštevilnejše zastopane, jih zasledimo v grobovih iz certoške⁶⁴⁶ in zgodnje negovske stopnje,⁶⁴⁷ medtem ko primerki z Vač, okolice Velikega Vinjega vrha oz. Šmarjete in iz Podzemlja nimajo znanih grobnih celot.⁶⁴⁸ Zaslediti jih je moč še na Notranjskem (Čepna pri Knežaku) ter v Panoniji (Szentés-Vekerzug).⁶⁴⁹

V magdalenskogorskih grobovih 2/13 in IV/30 s Prelog, ki sta vsebovala konjske brzde tipa IIA1 po Wernerju (= varianti 2 in 3 po Parducz), so zastopani tudi okrogli dvojni diski s punciranim okrasom (sl. 61: 4,

which may be traced on the north to the Baltic Sea into north-western Pannonia and to the west in Verucchio and Etruria, with the greatest concentration observed in southern Germany.⁶³⁵

The above-mentioned Grave IV/43 further revealed decorative two-knobbed buttons with a loop (fig. 61: 5).⁶³⁶ The earliest examples of such buttons were found in Thracio-Cimmerian context in the Holih rady hoard,⁶³⁷ while they were also unearthed in southern Germany in graves from Ha C and D1.⁶³⁸ In Dolenjska, they were found at Stična,⁶³⁹ Veliki Vinji vrh (Šmarjeta)⁶⁴⁰ and in Grave 2/57 at Preloge. The latter grave, with three-knobbed buttons (fig. 61: 7), dates to the Serpentine Fibulae phase.⁶⁴¹ Individual buttons from the Mecklenburg Collection are also published within the Late La Tène female Grave X/78 at Preloge⁶⁴² and among the finds from the tumuli at Stična.⁶⁴³ Similarly shaped decorative buttons are known in Etruria (Volterra) and Bavaria (Burggriesbach), where they date to the transition from the seventh to the sixth century BC,⁶⁴⁴ but also along the middle Don dating to the so-called Scythian period.⁶⁴⁵

Often appearing in combination with the so-called Scythian bridles are large and small round phalerae with two loops on the lower side (fig. 61: 12, 16, 17), determined by Parzinger as Type Magdalenska gora. They appeared most numerous in Dolenjska, with individual examples also known in Notranjska (Čepna near Knežak) and Pannonia (Szentés-Vekerzug).⁶⁴⁶ In Dolenjska, they were found in graves from the Certosa⁶⁴⁷ and early Negova phases,⁶⁴⁸ while the contexts

⁶³⁶ Hencken 1978, Fig. 84f, 85b.

⁶³⁷ Kossack 1954b, Abb. 29: B 3.

⁶³⁸ Egg 1985a, 367 ss, Abb. 36, 37 (karta razprostranjenosti).

⁶³⁹ Wells 1981, Fig. 161b; Egg 1985a, 367.

⁶⁴⁰ Stare V. 1973a, T. 18: 7,12; Egg 1985a, 367.

⁶⁴¹ Tecco Hvala/Dular/Kocuvan 2004, T. 52: 10.

⁶⁴² Hencken 1978, Fig. 362b.

⁶⁴³ Wells 1981, Fig. 31d, 161b.

⁶⁴⁴ Pauli 1966, 76, op. 5, Abb. 5: 3-8, 6: 2-4.

⁶⁴⁵ Preložnik 2007b, 157, Abb. 2; *Arheologija srednjega Dona v skifskuju èpohu* 2009, 320, Ris. 16: 8, 9.

⁶⁴⁶ *Magdalenska gora, gr. 2/13*: Tecco Hvala/Dular/Kocuvan 2004, T. 27: 39-43; *Stična, gr. 48/28, 48/54*: Gabrovec et al. 2006, T. 23: 3, 34: 6, 64: 2,3,193: 1-4, 199: 1 ter še Wells 1981, Fig. 43b, 160.

⁶⁴⁷ *Magdalenska gora, gr. V/6-7-7a, V/29*: Hencken 1978, Fig. 112j, 144c, 148a-c; *Novo mesto-Znančeve njive, gr. 4/3*: Knez 1986, T. 34: 9; *Novo mesto-Kapiteljska njiva, gr. 7/19*: Egg 1999, Abb. 10: 2-5.

⁶⁴⁸ *Podzemelj*: Dular J. 1978, T. 14: 27; *Vače*: neobjavljeno, NHMW inv. št. 14193; *Veliki Vinji vrh (Šmarjeta)*: Stare V. 1973a, 17: 41,42, 59: 5-8.

⁶⁴⁹ Parzinger/Nekvasil/Barth 1995, 71 ss, Abb. 25; Preložnik 2007b, 157, Abb. 1.

⁶³⁵ Kossack 1954b, 116 ff, 161, Karte 3: C, Abb. 1, 15: 7,8, 20B: 2, 21C: 9, 23A: 6, 24A: 14, 26B: 5; Guidi 1983, 27 f, 81: B3, T. 1:10, 26:B; Metzner-Nebelsick 1996, 295 f, Abb. 8; *Verucchio*: Gentili 2003, T. 63: 16, 79: 25, T. CXVIII: 16, CLIV: 25; *Tarquini*: Hencken 1968a, 575, Fig. 186j; Teržan 1995b, 92 f.

⁶³⁶ Hencken 1978, Figs. 84f, 85b.

⁶³⁷ Kossack 1954b, Abb. 29: B 3.

⁶³⁸ Egg 1985a, 367 ff, Abb. 36, 37 (distribution map).

⁶³⁹ Wells 1981, Fig. 161b; Egg 1985a, 367.

⁶⁴⁰ Stare V. 1973a, T. 18: 7,12; Egg 1985a, 367.

⁶⁴¹ Tecco Hvala/Dular/Kocuvan 2004, T. 52: 10.

⁶⁴² Hencken 1978, Fig. 362b.

⁶⁴³ Wells 1981, Figs. 31d, 161b.

⁶⁴⁴ Pauli 1966, 76, n. 5, Abb. 5: 3-8, 6: 2-4.

⁶⁴⁵ Preložnik 2007b, 157, Abb. 2; *Arheologija srednjega Dona v skifskuju èpohu* 2009, 320, Ris. 16: 8, 9.

⁶⁴⁶ Parzinger/Nekvasil/Barth 1995, 71 ff, Abb. 25; Preložnik 2007b, 157, Abb. 1.

⁶⁴⁷ *Magdalenska gora, Gr. 2/13*: Tecco Hvala/Dular/Kocuvan 2004, T. 27: 39-43; *Stična, Gr. 48/28, 48/54*: Gabrovec et al. 2006, T. 23: 3, 34: 6, 64: 2,3,193: 1-4, 199: 1 and Wells 1981, Figs. 43b, 160.

⁶⁴⁸ *Magdalenska gora, Gr. V/6-7-7a, V/29*: Hencken 1978, Figs. 112j, 144c, 148a-c; *Novo mesto-Znančeve njive, gr. 4/3*: Knez 1986, T. 34: 9; *Novo mesto-Kapiteljska njiva, gr. 7/19*: Egg 1999, Abb. 10: 2-5.

11),⁶⁵⁰ kakršne srečamo še v grobu 1 iz Špilerjeve gomile II na Libni.⁶⁵¹ Te pokope lahko datiramo v čas certoške stopnje. V starejšem okolju zasledimo take diske v južni Nemčiji, kjer se pojavljajo skupaj s trakokimerijsko konjsko opremo.⁶⁵²

Z brzdami variante 6 po Guštinu in Teržanovi oz. IIA2 po Wernerju pa se pogosto povezujejo križni gumbki z eno ali dvema zankama na spodnji strani (sl. 61: 15),⁶⁵³ ki so značilnost dolenskega prostora v poznem halštatskem obdobju. O stikih s skupnostmi v severovzhodnih Alpah in severozahodni Panoniji govorita najdbi takih gumbkov v Hallstattu in Szentlőrincu.⁶⁵⁴ Podobni so skitskemu okrasju z območja ob srednjem Donu.⁶⁵⁵ Primerki z japonskega prostora so mlajši in tudi nekoliko drugačni.⁶⁵⁶

Med najlepše primerke spadajo okrasni gumbki S-oblike in v obliki živalskih glav (sl. 61: 10) iz groba 2/13 na Magdalenski gori, ki so v dolenskem krogu unikatni. Gumbki S-oblike so nekako še najbolj podobni konjskemu okrasju skitsko-tračanskega živalskega stila, ki je bilo odkrito v Vinkovcih.⁶⁵⁷ Tudi okraski v obliki živalskih glav kažejo v spodnjepodonavsko smer (Craiova) vse tja do Dnjepra in morda še dlje proti vzhodu.⁶⁵⁸ Tam je moč najti paralele tudi za dolenske aplikacije v obliki svastike, kot je opozoril že Frey.⁶⁵⁹ Najstarejše okraske v obliki svastike s konjskimi protomi na Dolenskem predstavljajo bronasti primerki iz groba 48/99 iz Stične, ki je datiran v čas zgodnje certoške stopnje.⁶⁶⁰ Teržanova je zanje našla analogijo v Volkovcih ob Dnjepru.⁶⁶¹ Magdalenskogorske svastike (sl. 61: 21–23)⁶⁶² ter njim sorodni primerki iz Novega mesta in Dolenskih Toplic⁶⁶³ so izdelani iz svinčevo-cinkove zlitine in predstavljajo lokalne izdelke iz mlajše certoške oz. zgodnje negovske stopnje. Na svastiki iz magdalenskogorskega groba 2/38 s Prelog (sl. 61: 22) je Frey izpostavil zgovoren detajl, ki

⁶⁵⁰ Hencken 1978, Fig. 69a; Tecco Hvala/Dular/Kocuvan 2004, T. 27: 34,35.

⁶⁵¹ Guštin 1976, T. 3: 8.

⁶⁵² Kossack 1954b, Abb. 27: 7.

⁶⁵³ Hencken 1978, Fig. 109d, 144a,b, 158f.

⁶⁵⁴ Kruh 2008, 97 s, sl. 6.

⁶⁵⁵ Preložnik 2007b, 157, Abb. 3; *Arheologija srednjega Dona v skifskuju èpohu* 2009, 320, Ris. 16: 4-7.

⁶⁵⁶ Kruh 2008, l.c.

⁶⁵⁷ Majnarić-Panžić 1999–2000, 28 s, sl. 4: 1,2,6,7; Preložnik 2007b, 161 s, Abb. 20. Sorodnosti bi morda lahko videli tudi v nekaterih primerkih z območja srednjega Dona: *Arheologija srednjega Dona v skifskuju èpohu* 2009, 317, Ris. 13: 2,4.

⁶⁵⁸ Frey 1980c, 227 ss, Abb. 2: 3; Kull 1997, 213 ss, Abb. 13; Preložnik 2007b, 161 s, Abb. 17–19.

⁶⁵⁹ Frey 1980c, 227 ss; Kull 1997, Abb. 7: 6,17, 8: 1,3.

⁶⁶⁰ Gabrovec et al. 2006, T. 57: 10-13.

⁶⁶¹ Teržan 2008, 291, sl. 41.

⁶⁶² Hencken 1978, Fig. 52b, 151 d; Tecco Hvala/Dular/Kocuvan 2004, T. 35: 15.

⁶⁶³ *Novo mesto-Kapiteljska njiva, gr. 3/12: Križ* 1997, T. 36: 6; *Dolenske Toplice, gr. 5/33: Teržan* 1976, T. 38: 2,3.

for such phalerae from Vače, vicinity of Veliki Vinji vrh (Šmarjeta) and Podzemelj are not known.⁶⁴⁹

Graves 2/13 and IV/30 at Preloge, which contained bridle-bits of Type IIA1 after Werner (= Variants 2 and 3 after Parducz), revealed double discs with punched decoration (fig. 61: 4, 11).⁶⁵⁰ Such objects were also found in Grave 1 from Špiler's Tumulus II at Libna⁶⁵¹ together with a double-crested helmet, a bronze situla, weapons and other goods. They can be dated to the Certosa phase, while earlier examples are evidenced in southern Germany together with Thracian-Cimmerian horse gear.⁶⁵²

Often found together with the Dolenska variant of the co-called Scythian bit mouth-piece (= Variant 6 after Guštin and Teržan or IIA2 after Werner) were cruciform buttons with one or two loops on the lower side (fig. 61: 15),⁶⁵³ which are characteristic of Dolenska in the final phase of the Hallstatt period. The contacts between communities in the north-eastern Alps and north-western Pannonia are evidenced by the finds of such buttons at Hallstatt and Szentlőrinc,⁶⁵⁴ which are similar to the Scythian decoration from the middle Don region.⁶⁵⁵ The examples from the Iapodic area are later and somewhat different.⁶⁵⁶

The most beautiful are the decorative buttons, S- and animal-head shaped, from Grave 2/13 at Magdalenska gora (fig. 61: 10), which are unique within the Dolenska circle. The S-shaped buttons bear most resemblances with the horse decorations of the Scythian-Thracian animal style found at Vinkovci.⁶⁵⁷ The animal-heads decoration also points towards the middle Danube basin (Craiova) all to the Dnieper and possibly even further to the east.⁶⁵⁸ That area also provides parallels for the swastika-shaped appliques from Dolenska, as observed already by Frey.⁶⁵⁹ The earliest context with swastika decorations and horse protomes in Dolenska is Grave Group 48/99 from Stična, dated to the Early Certosa phase,⁶⁶⁰ for which Teržan found an analogy at

⁶⁴⁹ *Podzemelj*: Dular J. 1978, T. 14: 27; *Vače*: unpublished, NHMW Inv. No. 14193; *Veliki Vinji vrh (Šmarjeta)*: Stare V. 1973a, 17: 41,42, 59: 5-8.

⁶⁵⁰ Hencken 1978, Fig. 69a; Tecco Hvala/Dular/Kocuvan 2004, T. 27: 34,35.

⁶⁵¹ Guštin 1976, T. 3: 8.

⁶⁵² Kossack 1954b, Abb. 27: 7.

⁶⁵³ Hencken 1978, Figs. 109d, 144a,b, 158f.

⁶⁵⁴ Kruh 2008, 97 f, Abb. 6.

⁶⁵⁵ Preložnik 2007b, 157, Abb. 3; *Arheologija srednjega Dona v skifskuju èpohu* 2009, 320, Ris. 16: 4-7.

⁶⁵⁶ Kruh 2008, l.c.

⁶⁵⁷ Majnarić-Panžić 1999–2000, 28 f, Figs. 4: 1,2,6,7; Preložnik 2007b, 161 f, Abb. 20. Similar examples are known from the Middle Don region: *Arheologija srednjega Dona v skifskuju èpohu* 2009, 317, Ris. 13: 2,4.

⁶⁵⁸ Frey 1980c, 227 ff, Abb. 2: 3; Kull 1997, 213 ff, Abb. 13; Preložnik 2007b, 161 f, Abb. 17–19.

⁶⁵⁹ Frey 1980c, 227 ff; Kull 1997, Abb. 7: 6,17, 8: 1,3.

⁶⁶⁰ Gabrovec et al. 2006, T. 57: 10-13.

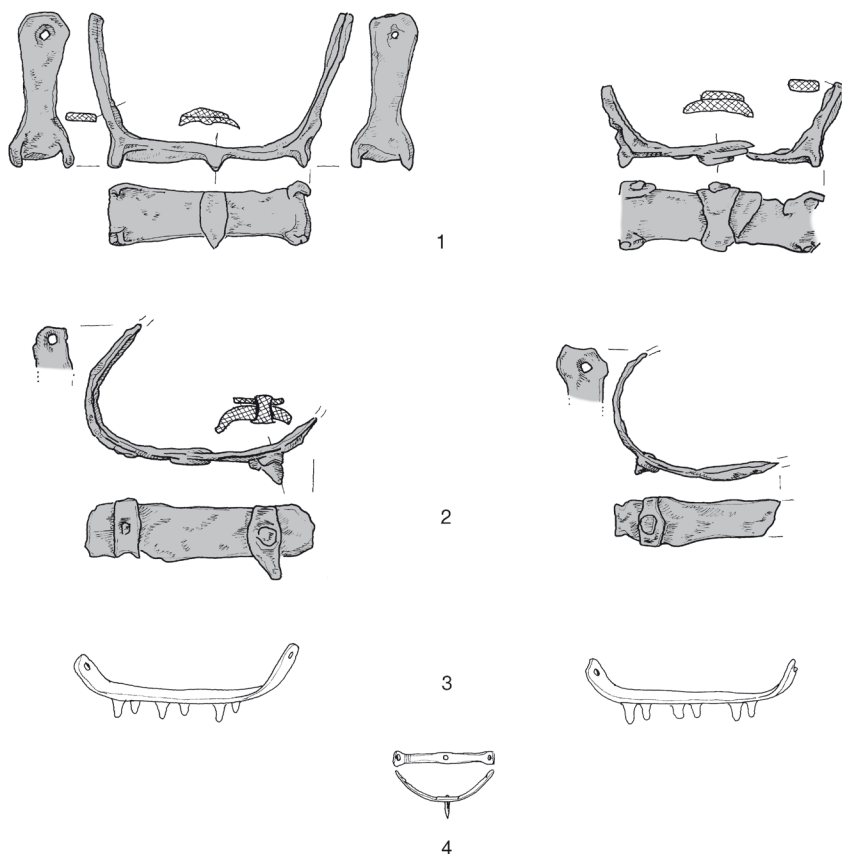

Sl. 62: Dereze in ostroga z Magdalenske gore. 1, 2 – železo; 3, 4 – bron. M. = 1:4.
 Fig. 62: Crampons and a spur from Magdalenska gora. 1, 2 – iron; 3, 4 – bronze. Scale = 1:4.
 1 – Laščik, gr. 12/1; 2 – Preloge, gr. 2/13; 3 – Preloge, gr. IV/43; 4 – Preloge, gr. IV/32.

kaže na sinkretizem v dolenskem ustvarjanju; gre za upodobitev konjske glave s človeško nogo v gobcu, kar je motivika situlske umetnosti.⁶⁶⁴

Iz tega pregleda je moč videti, da se v konjski opremi dolenskega prostora mešajo različne kulturne prvine, ki so svojevrstni smerokazi stikov in poti na dolge razdalje, kar pravzaprav niti ne preseneča, saj je konj v tistem času predstavljal najhitrejši način premagovanja velikih razdalj po kopnem ter kot tak ponazarjal prestiž in status svojega lastnika.

4.3.2 OSTROGE

Za brzdanje konja so poleg vajeti dozvedno uporabljali še druge pripomočke, kot so ostroge (sl. 62: 4) in bič ali šiba. V grobovih biči in šibe sicer niso ohranjeni, vendar o njihovi uporabi govorijo upodobitve situlske umetnosti,⁶⁶⁵ medtem ko so ostroge v halštatski kul-

Volkovci along the Dnieper.⁶⁶¹ The swastikas from Stična are made of bronze, while those found at Magdalenska gora (fig. 61: 21–23),⁶⁶² as well as the two examples from Novo mesto and Dolenske Toplice,⁶⁶³ were made of a lead-zinc alloy and represent local products dating to the Late Certosa or Early Negova phases. Frey further observed a detail on the swastika from Grave 2/38 at Preloge (fig. 61: 22), namely a situla art motif of a horse's head with a human foot in its mouth, which points to a syncretism of the Dolenska production.⁶⁶⁴

The above overview of the horse gear found in Dolenska revealed a mixing of cultural elements, which serve as indicators of contacts and long-distance routes. This is no surprise, since the horse represented the fastest

⁶⁶¹ Teržan 2008, 291, Abb. 41.

⁶⁶² Hencken 1978, Figs. 52b, 151 d; Tecco Hvala/Dular/Kocuvan 2004, T. 35: 15.

⁶⁶³ *Novo mesto-Kapiteljska njiva, Gr. 3/12*: Križ 1997, T. 36: 6; *Dolenske Toplice, Gr. 5/33*: Teržan 1976, T. 38: 2,3.

⁶⁶⁴ Frey 1980c, 236; Abb. 1, 2: 1; 4: 17; Gabrovec 1987, 63; Preložnik 2007b, 159 ss, Abb. 10–13.

⁶⁶⁵ Eibner 2009, 21 ss, T. 2: 8, 5, 6.

⁶⁶⁴ Frey 1980c, 236; Abb. 1, 2: 1; 4: 17; Gabrovec 1987, 63; Preložnik 2007b, 159 ff, Abb. 10–13.

turi za zdaj poznane le na Dolenjskem in predstavljajo pomembno novost.⁶⁶⁶ Na Magdalenski gori je bronasta ostroga zabeležena v sklopu grobne celote IV/32 s Prelog, kjer pa je Goldberg ne omenja.⁶⁶⁷ Na drugih dolenskih najdiščih so izpričane v grobovih iz mlajše certoške in zgodnje negovske stopnje. Izdelane so iz bron, le primerek iz Novega mesta je železen.⁶⁶⁸ Nazadnje jih je obravnaval Egg in pokazal, da se ostroge v tistem času pojavljajo v južni Italiji in Grčiji.⁶⁶⁹

4.3.3 DEREZE

Dereze nimajo neposredno opraviti s konjem ali ježo, čeprav jih na Magdalenski gori srečamo skupaj s konjsko opremo (Preloge, gr. 2/13, IV/43). En železen par (sl. 62: 1) je bil najden v žganem grobu 12/1 na Laščiku iz časa stopnje Podzemelj 2 (sl. 54); drugi par (sl. 62: 2) je pripadal vodilnemu predstavniku mlajše certoške stopnje, pokopanemu v grobu 2/13 na Prelogah (sl. 54); tretji par, izdelan iz bron, pa je objavljen v sklopu grobne celote IV/43 s Prelog (sl. 62: 3), vendar ga Goldberg v opisu tega groba ne navaja.⁶⁷⁰ Železni primerki derez so na Dolenjskem znani še iz Stične in z Vač, toda brez ohranjenih grobnih celot.⁶⁷¹

Dereze nas vodijo v gorati alpski svet,⁶⁷² njihov pojav in razširjenost je nazadnje osvetlil Tomedi in pokazal, da se bronasti primerki pojavljajo v depojih s konca kulture žarnih grobišč oz. z začetka železne dobe, da so železne različice izpričane v halštatskih grobiščih na Koroškem, Tirolskem in v samem Hallstattu, medtem ko so bile v tridentinskem Sanzenu in Clesu najdene v okviru kulturnega prostora.⁶⁷³ Pojavljajo se torej v različnih okoljih in niso kronološko indikativne. Morda poudarjajo povezanost pokojnika s tovarništvom⁶⁷⁴ in trgovskimi karavanami, ki so hodile v Hallstatt po sol.

4.4 PASNE SPONE

Med pogoste dodatke k opravam pripadnikov magdalenskogorske skupnosti spadajo pasne spone, ki so izdelane iz železa, bron ali v kombinaciji obeh kovin.

⁶⁶⁶ Teržan 1998, 529; Egg 1999, 335 ss.

⁶⁶⁷ Hencken 1978, 23, Fig. 72e.

⁶⁶⁸ *Brezje*, gr. 7/16, 13/49: Kromer 1959a, T. 28: 9, 43: 9; *Dolenjske Toplice*, gr. 2/23: Teržan 1976, 387, T. 11: 8; *Novo mesto-Kapiteljska njiva*, gr. 7/19: Egg 1999, Abb. 8: 12; *Vače*: neobjavljeno, NHMW inv. št. 14221.

⁶⁶⁹ Egg 1999, 335 ss, Abb. 14.

⁶⁷⁰ Hencken 1978, 25 s, Fig. 84d,e; Tecco Hvala/Dular/Kocuvan 2004, 24, 35 s, T. 6B: 1,2; 27: 45,46.

⁶⁷¹ Stare F. 1955a, T. 17: 11; Gabrovec et al. 2006, T. 146: 14,15.

⁶⁷² Gabrovec 1987, 66, sl. 4: 5.

⁶⁷³ Tomedi 2002, 152 ss, Abb. 33.

⁶⁷⁴ Teržan 2008, 279.

means of transport of the day and, as such, embodied the prestige and status of its owner.

4.3.2 SPURS

Besides the rein, horses were also controlled by means of other objects, such as spurs (fig. 62: 4), whips or rods. Whips and rods have not been preserved in graves, though their use is suggested by the motifs of the situla art.⁶⁶⁵ Spurs from the Hallstatt period, on the other hand, have been found, but thus far only in Dolenjska and represent an important novelty.⁶⁶⁶ At Magdalenska gora, a bronze spur was recorded in Grave IV/32 at Preloge, though not by Goldberg.⁶⁶⁷ Other sites in Dolenjska revealed spurs in graves from the Late Certosa and Early Negova phases. They are bronze with the exception of an iron example found in Novo mesto.⁶⁶⁸ The last to study spurs was Egg, who showed that at this time spurs appeared in southern Italy and Greece.⁶⁶⁹

4.3.3 CRAMPONS

Crampons are not directly connected to the horse or to riding, but they were found together with horse gear at Magdalenska gora (Preloge, Gr. 2/13, IV/43). One iron pair (fig. 62: 1) was found in cremation Grave 12/1 at Laščik dated to the Podzemelj 2 phase (fig. 54); the other pair (fig. 62: 2) belonged to the leading representative of the Late Certosa phase buried in Grave 2/13 at Preloge (fig. 54); while the third pair, made of bronze, was published as part of Grave IV/43 at Preloge (fig. 62: 3), though Goldberg made no mention of it in his description of the grave.⁶⁷⁰ Iron crampons in Dolenjska were also found at Stična and Vače, though without preserved grave groups.⁶⁷¹

Crampons indicate an alpine environment.⁶⁷² Their appearance and distributions was last studied by Tomedi, who showed that bronze crampons appeared in hoards at the end of the Urnfield culture period and beginning of the Iron Age and that iron crampons were found in Hallstatt-period cemeteries in Carinthia, Tirol and at Hallstatt itself, while they appeared in Tridentine

⁶⁶⁵ Eibner 2009, 21 ff, T. 2: 8, 5, 6.

⁶⁶⁶ Teržan 1998, 529; Egg 1999, 335 ff.

⁶⁶⁷ Hencken 1978, 23, Fig. 72e.

⁶⁶⁸ *Brezje*, Gr. 7/16, 13/49: Kromer 1959a, T. 28: 9, 43: 9; *Dolenjske Toplice*, Gr. 2/23: Teržan 1976, 387, T. 11: 8; *Novo mesto-Kapiteljska njiva*, Gr. 7/19: Egg 1999, Abb. 8: 12; *Vače*: unpublished, NHMW Inv. No. 14221.

⁶⁶⁹ Egg 1999, 335 ff, Abb. 14.

⁶⁷⁰ Hencken 1978, 25 f Fig. 84d,e; Tecco Hvala/Dular/Kocuvan 2004, 24, 35, 123, 129, T. 6B: 1,2; 27: 45,46.

⁶⁷¹ Stare F. 1955a, T. 17: 11; Gabrovec et al. 2006, T. 146: 14,15.

⁶⁷² Gabrovec 1987, 66, Fig. 4: 5.

V nadaljevanju so predstavljene po posameznih vrstah glede na kovino, obliko in način izdelave. Po obliki jih lahko ločimo na rombične, pravokotne in trikotne. Po načinu izdelave pa jih lahko delimo na kovane, izdelane iz pločevine in na ulite v predrti tehniki. Na nekaterih se pojavljajo tudi razne okrasne prvine.

4.4.1 ŽELEZNE ROMBIČNE IN PRAVOKOTNE SPONE

Tipološke značilnosti. Železne pasne spono z Magdalenske gore so pravokotne ali rombične oblike (sl. 63). Na pravokotnih primerkih večkrat zasledimo bronaste zakovice (sl. 63: 1, 3, 4), ki so zaradi kontrasta kovin učinkovale okrasno ali pa je bronasta prevleka odpadla, kajti obstajajo tudi take železne ploščice, ki so prevlečene z bronasto pločevino (sl. 65: 8). Mestoma so na spodnji strani vidni tudi prirjaveli ostanki ali odtisi tkanine (sl. 63: 1, 2). Rombične pasne spono so različnih velikosti, ene so bolj iztegnjene (sl. 63: 7–10), druge so krajše (sl. 63: 15–17), največ pa jih lahko uvrstimo med oba ekstrema; večina je imela en konec ukrivljen v kavelj, medtem ko je bil drugi verjetno razcepljen v dva kraka. Iz železa so tudi kavljaste spono s sredinsko prečko (sl. 69: 2, 3) ter nekatere predrti (sl. 69: 6, 7), ki jih obravnavam skupaj z enako oblikovanimi bronastimi izdelki.

Lega in kontekst. Železne spono rombične oblike so bile velikokrat edini ohranjeni kos oprave umrlega (sl. 64).⁶⁷⁵ V teh primerih jih ni mogoče pripisati določeni spolni ali starostni skupini, saj ni na voljo osteoloških podatkov. Vendar se pojavljajo tudi v kombinaciji z nožem in suličnimi ostmi, kar kaže na moško nošo.⁶⁷⁶ V več pogledih med njimi izstopa možak, pokopan v grobu 13/10 na Prelogah (sl. 29 in 54), ki je bil sežgan, ostanki pa skupaj s prdatki (bodalom, sulici, brus, apulska kraterja) položeni na leseno kotanjasto podlogo. To je edini žgani grob s tako pasno spono, druge so bile najdene v skeletnih grobovih.⁶⁷⁷ Pripadnik iz iste gomile, pokopan v grobu 13/69, je imel menda še eno bronasto spono pravokotne oblike, okrašeno s koncentričnimi krožci in račkami, vendar sta obe izgubljeni. V grobu 13/17 zasledimo železno rombično spono v kombinaciji z majhno narebreno zapetnico; s tipično ženskimi prdatki nastopa tudi v grobu 13/36, v katerem sta bila najdena še nož in brus, kar bi kazalo na dvojni pokop, vendar Brattina omenja le en skelet.⁶⁷⁸ V gomili 2 na Prelogah je bila najdena

⁶⁷⁵ Npr. Preloge, gr. 13/25, 13/59, 13/76, 13/78, 13/169.

⁶⁷⁶ Laščik, gr. V/9; Preloge, gr. VIII/8, X/62, X/70, 2/82, 13/10, 13/69.

⁶⁷⁷ Hencken 1978, Fig. 4d, 43a, 114j, 281b, 331g, 282a, 349a, 354d; Tecco Hvala/Dular/Kocuvan 2004, T. 60A: 6, 62D: 5, 68: 2; 70B: 2, 74A: 1, 76: 23, 86C: 1, 90H: 1, 92A: 1, 125C: 1, 137D: 4, 138: 13, 158: 3,4.

⁶⁷⁸ Tecco Hvala/Dular/Kocuvan 2004, 58, T. 76, 77A.

Sanzeno and Cles within a cult place.⁶⁷³ Crampons thus appeared in different areas and are not chronologically indicative, though they may point to the deceased being related to transport of goods⁶⁷⁴ and trade caravans that transported salt from Hallstatt.

4.4 BELT CLASPS

Belt clasps represent a frequent addition to the costume of the members of the Magdalenska gora community. They are made either of iron or bronze, or of a combination of the two. The overview below presents them according to type as well as metal, form (rhombic, rectangular, triangular) and production manner (forged, made of sheet metal or cast with openwork). Some belt clasps even bear decorative elements.

4.4.1 IRON RHOMBIC AND RECTANGULAR CLASPS

Typological characteristics. Iron belt clasps from Magdalenska gora are either rectangular or rhombic in form (fig. 63). Several rectangular clasps have bronze rivets (fig. 63: 1, 3, 4), which either had a decorative effect due to the different colour of metals or the clasp had a bronze coat that had fallen off; the latter is suggested by finds of small iron plates coated with a sheet of bronze (fig. 65: 8). Sometimes visible on the lower side are remains or imprints of cloth rusted to the clasp (fig. 63: 1, 2). The rhombic belt clasps are of various sizes, some elongated (fig. 63: 7–10) and others short (fig. 63: 15–17), though most fall between the two extremes. Most had one end curved into a hook, while the other end was split into two prongs. Hook clasps with a central bar are also made of iron (fig. 69: 2, 3), as are some of the openwork clasps (fig. 69: 6, 7), which are discussed below, together with the bronze examples.

Position and context. Iron clasps of rhombic shape were often the only preserved piece of costume (fig. 64).⁶⁷⁵ They cannot be attributed to either a particular sex or age group, since no osteological analyses for these graves could be performed. They were, however, found in combination with a knife and spearheads, which suggests a male costume.⁶⁷⁶ Exceptional in several aspects, also in clasps, is Grave 13/10 at Preloge (figs. 29 and 54). It contained cremated remains of a male laid onto wooden bedding together with the grave goods consisting of a dagger, two

⁶⁷³ Tomedi 2002, 152 ff, Abb. 33.

⁶⁷⁴ Teržan 2008, 279.

⁶⁷⁵ For example Preloge, Gr. 13/25, 13/59, 13/76, 13/78, 13/169.

⁶⁷⁶ Laščik, Gr. V/9; Preloge, Gr. VIII/8, X/62, X/70, 2/82, 13/10, 13/69.

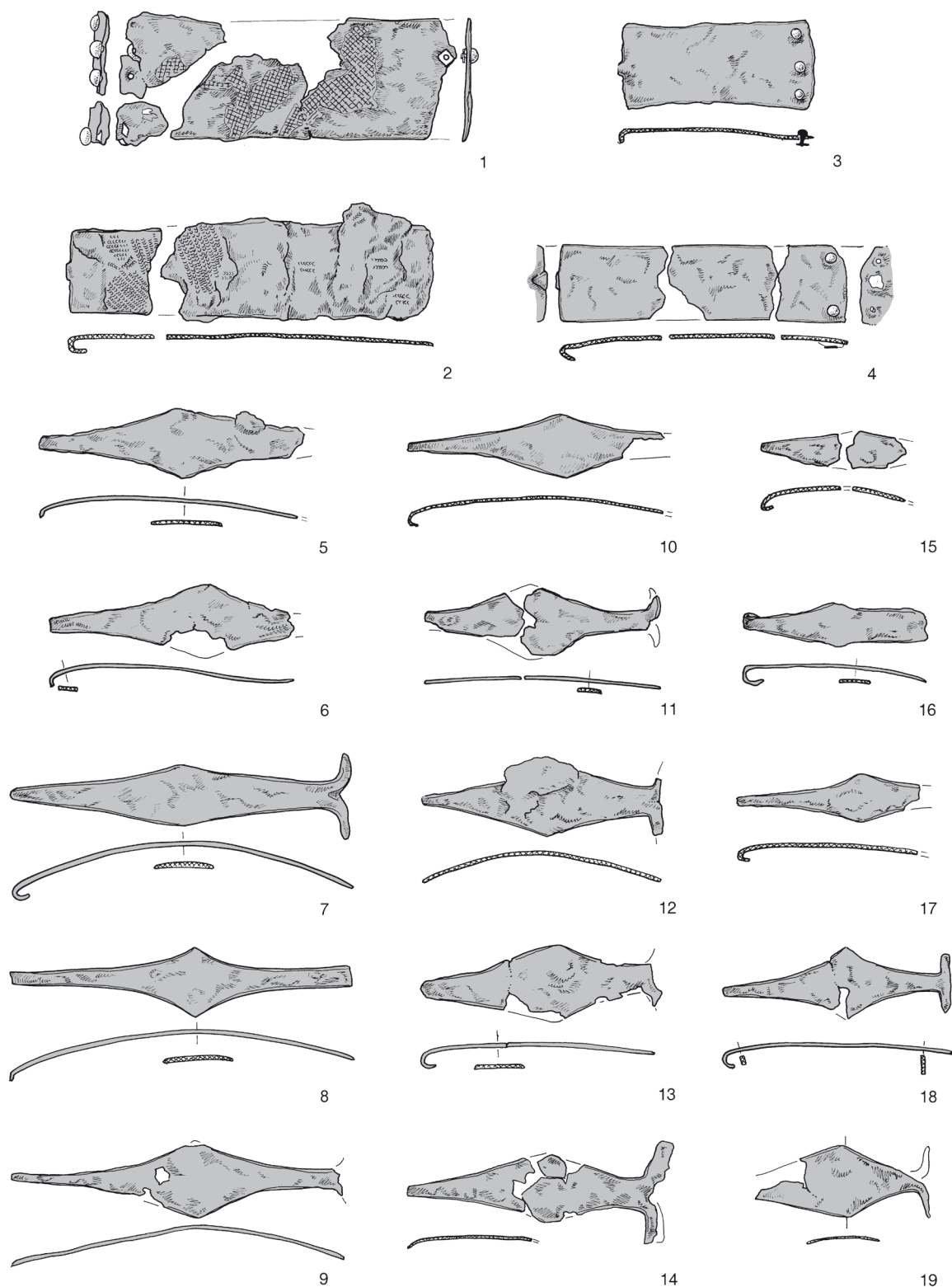

Sl. 63: Železne pasne spone z Magdalenske gore. M. = 1:4.

Fig 63: Iron belt clasps from Magdalenska gora. Scale = 1:4.

1 – Laščik, gr. V/23; 2 – Preloge, gr. 2/57; 3 – Preloge, gr. 13/152; 4, 18 – najdbi brez znane grobne celote v NMS / finds without preserved contexts kept in NMS; 5 – Preloge, gr. 13/17; 6 – Preloge, gr. 13/78; 7 – Preloge, gr. 13/25; 8 – Preloge, gr. 13/36; 9 – Preloge, gr. VIII/6; 10 – Preloge, gr. X/39; 11 – Preloge, gr. 13/59; 12 – Preloge, gr. 2/73; 13 – Preloge, gr. 13/10; 14 – Preloge, gr. VIII/8; 15 – Preloge, gr. 2/82; 16 – Preloge, gr. 13/76; 17 – Voselca, gr. 2/19; 19 – Preloge, gr. X/62.

Gom. / Gr. Tum. / Gr.	Pokop / Burial rite	Spol / Starost Sex / Age	Tipi pasnih spon / Types of belts	Št. pasnih spon / No. of belts	Pasni okovi / Belt attachments	Fibule / Fibulae	Čelada / Helmet	Sekire / Axes	Sulice / Spears	Noži / Knives	Bodalo / Dagger	Šilo / Awl	Brus / Whetstone	Konjska oprema / Horse gear	Uhani / Earrings	Ovratnice / Neckrings	Steklene oz. jantarne jagode Glass or amber beads	Zapestnice / Bracelets	Nanožnice / Anklets	Scepter / Sceptre	Lončenina / Pottery	Bronasto posodje / Bronze vessels
P 13/169	S	?	◇	1																		
P 13/76	S	?	◇	1																		1
P 13/78	S	?	◇	1																		1
P 13/59	S	?	◇	1																		1
P 13/25	S	?	◇	1	br																	1
P VIII/8	S	M	◇	1	br					1												
P 13/10	C	M	◇	1					2	1	1											3
P 2/82	S	M	◇	1	br	1			1	1		2										1
L V/9	S	M	◇	1	Fe	2			1	1							8					
P X/70	S	M	◇	1	br	1				1												
P 2/73	S	?	◇	1	br	1										1						
V 2/18	S	?	◇	1	br	2												2				
P 13/36	S	F+M?	◇	1		2				1			1		2	x	4	2				1
V 2/19	S	F	◇	1		4									2	x	1	2				
P 13/17	S	?	◇	1														1				1
P 13/69	S	M	◇◻	2	br	1				1							2					1
P X/62	S	M	◇■	1						1												
P 13/152	S	F	■	1	Fe	1									2	x	2		1			6
P 13/77	S	F+I	■	1	Fe											1	x	2+2				1
L V/23	S	M	■	1	br	2				1												
P IV/21	S	M	■	1		1			2	1												1
P VIII/2	S	M	■	1					2	1												
P 2/60	S	M	■	1		2		1	1	1				x								
P 2/57	S	M	■◻	2		2	1	1	2	1				x								4 3
P VI/33	S	M	?	1					2	1												
L V/15	S	M	?	1					1	1												
P II/20	?	?	?	1																		1

Sl. 64: Struktura pridatkov v grobovih z železnimi pasnimi sponami na Magdalenski gori.

Fig. 64: Structure of goods in the graves with iron belt clasps at Magdalenska gora.

◇ = železna rombična / iron rhombic clasp, ■ = železna pravokotna / iron rectangular clasp,

◻ = bronasta pravokotna spona / bronze rectangular clasp.

v grobu 2/73 skupaj z bronasto narebreno ovratnico in trakasto fibulo. Kakšna fibula je bila najdena v grobu 2/82, ni znano, ker je Pečnik ni podrobneje opisal, v inventarni knjigi dunajskega muzeja pa ni zavedena.⁶⁷⁹ Na Voselci je železna rombična spona zabeležena v dveh grobovih iz gomile 2. V ženskem grobu 2/19 Pečnik med drugim navaja štiri fibule, inventariziranih pa jih je šest (fibula s stekleno oblogo, drobna čolničasta fibula, dve kačasti, certoška vrste II in celo zgodnjelatenska fibula), ki niso vse iz istega časa. V grobu 2/18 nastopa v kombinaciji s certoškima fibulama vrste V, zapestnico in obročki z izrastki. Najdene so bile tudi v okviru izkopavanja vojvodinje

spears, a whetstone and two Apulian *kratere*. It represents the only cremation burial with such a belt clasp, all others being inhumations.⁶⁷⁷ A member of the same tumulus, buried in Grave 13/69, reportedly had another bronze clasp, rectangular, which was decorated with concentric circles and small ducks, though both clasps are now lost. Grave 13/17 revealed an iron rhombic clasp in combination with a small ribbed bracelet. Another such clasp was found with typically female attributes also in Grave 13/36,

⁶⁷⁷ Hencken 1978, Figs. 4d, 43a, 114j, 281b, 331g, 282a, 349a, 354d; Tecco Hvala/Dular/Kocuvan 2004, T. 60A: 6, 62D: 5, 68: 2; 70B: 2, 74A: 1, 76: 23, 86C: 1, 90H: 1, 92A: 1, 125C: 1, 137D: 4, 138: 13, 158: 3,4.

⁶⁷⁹ Ibid., 48.

Mecklenburške – dve v gomili VIII in tri v gomili X na Prelogah ter ena v gomili V na Laščiku.⁶⁸⁰ Železne pasne spono omenja Goldberg še v grobovih II/20 in VI/33 s Prelog ter V/15 z Laščika, ne da bi opisal njihovo obliko, v teh sestavih namreč niso objavljene (sl. 64). Konteksti, v katerih nastopajo železne rombične spono na Magdalenski gori, kažejo, da so jih nosili tako moški kot ženske.

Enako lahko ugotovimo za železne pravokotne pasne spono (sl. 63: 1–4),⁶⁸¹ vendar so pretežno spadale v bojeviške oprave (sl. 64). Zasedimo jih celo v najelitnejših moških grobovih z dvogrebenasto čelado (Preloge, gr. 2/57 in 2/g),⁶⁸² pa tudi v bogatejših ženskih opravah. Brattina je zapisal, da je imela pokojnica v grobu 13/152 s Prelog na bokih okrašeno bronasto ploščevino z visečimi bobenčki (sl. 126: b) in zraven sceptor, medtem ko je bila železna rombična spona skupaj s kačasto fibulo zatakajena med dve posodi pri pokojničinih nogah. Pokojnica v grobu 13/77 s Prelog, ki sta jo krasili votla ovratnica in ogrlica, pa je imela tako spono pri kolkah, zraven nje je bil pokopan tudi otrok. Iz povedanega lahko zaključimo, da nastopajo železne pravokotne spono v bogatejših opravah kot rombične.

Razširjenost in časovni okvir. Na teritoriju dolenske halštatske skupnosti je zabeleženih kar precej železnih pasnih spon rombične oblike.⁶⁸³ Večinoma se pojavljajo v skeletnih grobovih; v žganem grobu jo razen na Magdalenski gori (Preloge, gr. 13/10) zasedimo še v Stični v grobu 48/30 s t. i. svetolucijskim pitosom in kelihasto posodo na nogi,⁶⁸⁴ ter v Podzemlju v grobu 28/1 iz Grma, ki je vseboval žaro v obliki bikoničnega lonca z izvihanim ustjem in latvico.⁶⁸⁵ Njihov vznik v stopnji Stična nakazuje grobova z Gabrja pod Gorjanci in s Kavčevega hriba pri Suhadolah v Posavskem hribovju, kjer nastopata v kombinaciji s čolničasto fibulo,⁶⁸⁶ tovrstne fibule pa so značilne za žensko nošo. Toda večina rombičnih pasnih spon spada k moškim opravam z

⁶⁸⁰ Gr. V/9, VIII/6, VIII/8, X/39, X/62, X/70.

⁶⁸¹ Hencken 1978, Fig. 43b, 57g, 127g,h, 277b; Tecco Hvala/Dular/Kocuvan 2004, 51: 3, 56: 3, 91: 11, 118: 16, 125A: 1, 157: 1,2.

⁶⁸² Grobni sestav 2/g, v katerem se omenja fragment železne spono, ni v celoti rekonstruiran.

⁶⁸³ *Brezje*: Kromer 1959a, T. 13: 4, 27: 10, 42: 5; *Dole pri Litiji*: Dular J. 2003, T. 89: 9; *Gabrje*: Dular J. 2003, T. 4: 9; *Javor*: Guštin/Knific 1973, T. 1: 4, 4: 7; *Libna*: Guštin 1976, T. 5: 7, 40: 12, 50: 5, 54: 1; *Mokronog*: neobjavljeno, NMS inv. št. P 1547, 1548; *Podturn*: Dular J. 2003, T. 26: 1; *Podzemelj*: Barth 1969, T. 26: 9, 28: 4, 35: 7,8, 37: 8,9; *Stična*: Gabrovec et al. 2006, T. 25: 2; *Suhadole*: Dular J. 2003, T. 91: 6; *Vače*: Stare F. 1955a, T. 52: 2, 53: 1,2 in neobjavljeni primerki, NHMW inv. št. 8019, 8124, 8083; *Veliki Vinji vrh (Šmarjeta)*: Stare V. 1973a, T. 16: 2,3,5, 67: 20; *Dular A.* 1991, T. 14: 4; *Volčje Njive*: Gabrovec 1956, T. 11: 2; *Zagorica pri Čatežu*: Dular J. 2003, T. 39: 1,2.

⁶⁸⁴ Gabrovec et al. 2006, 38, T. 25: 1-4.

⁶⁸⁵ Barth 1969, 135, T. 26: 7-9.

⁶⁸⁶ *Gabrje, gr. 1/2; Suhadole - Kavčev hrib (plano grobišče)*, gr. 5: Dular J. 2003, 159, 271, T. 4: 6-9, 91: 4-6.

which further revealed a knife and a whetstone suggesting a double burial, though Brattina only mentions one skeleton.⁶⁷⁸ In Tumulus 2 at Preloge, a rhombic clasp was found in Grave 2/73 together with a bronze ribbed torques and a fibula with a flat bow. The type of fibula found in Grave 2/82 is not known, since Pečnik offered no detail description, while it is not registered in the inventory book of the museum in Vienna.⁶⁷⁹ At Voselca, an iron rhombic clasp was documented in two graves from Tumulus 2. In the first, female Grave 2/19, Pečnik recorded four fibulae among the grave goods, while six are inventoried that do not belong to the same period (fibula with a glass overlay, small boat fibula, two serpentine, a Type II Certosa and even an Early La Tène fibula). The second is Grave 2/18, where the clasp was found in combination with two Type V Certosa fibulae, a bracelet and rings with knobs. Rhombic belt clasps were also found during the excavations by the Duchess of Mecklenburg – two in Tumulus VIII and three in Tumulus X at Preloge, as well as one in Tumulus V at Laščik.⁶⁸⁰ Goldberg also mentions iron belt clasps, without specifying their type, in Graves II/20 and VI/33 at Preloge and V/15 at Laščik, though they are not included in the publication of the enumerated graves (fig. 64). To conclude, the contexts presented above show a unisex use of the iron rhombic clasps at Magdalenska gora.

A similar conclusion could be reached for the rectangular iron belt clasps (fig. 63: 1–4),⁶⁸¹ though most formed part of the warrior outfit (fig. 64). They were even found in the most elite male graves with a double-crested helmet (Preloge, Gr. 2/57 and 2/g),⁶⁸² but also as parts of the rich female costume. Brattina noted that the female in Grave 13/152 at Preloge had a decorated bronze sheet with drum-like pendants at the hips (fig. 126: b) and beside it a sceptor, while the iron rhombic clasp was stuck between two vessels at the feet together with a serpentine fibula. The female buried in Grave 13/77 at Preloge, adorned by a hollow torques and a necklace, had such a clasp at the hips. Buried beside her was a child. In comparison to the rhombic clasps, the rectangular ones formed part of richer costumes.

Distribution and time frame. A relatively high number of iron belt clasps of rhombic shape have been documented on the territory of the Dolenska Hallstatt community.⁶⁸³ They were mostly found in inhumation

⁶⁷⁸ Tecco Hvala/Dular/Kocuvan 2004, 58, 146, T. 76, 77A.

⁶⁷⁹ *Ibid.*, 48, 139.

⁶⁸⁰ Gr. V/9, VIII/6, VIII/8, X/39, X/62, X/70.

⁶⁸¹ Hencken 1978, Figs. 43b, 57g, 127g,h, 277b; Tecco Hvala/Dular/Kocuvan 2004, 51: 3, 56: 3, 91: 11, 118: 16, 125A: 1, 157: 1,2.

⁶⁸² Grave Group 2/g, which reportedly contained a fragment of an iron clasp, is neither preserved nor completely reconstructed.

⁶⁸³ *Brezje*: Kromer 1959a, T. 13: 4, 27: 10, 42: 5; *Dole pri Litiji*: Dular J. 2003, T. 89: 9; *Gabrje*: Dular J. 2003, T. 4: 9; *Javor*: Guštin/Knific 1973, T. 1: 4, 4: 7; *Libna*: Guštin 1976,

orožjem ali orodjem (šilom in brusom). Kronološko so najbolj zgovorni sestavi, v katerih se pojavljajo fibule. Zasledimo jih v kombinacijah s kačastimi fibulami s pestiči⁶⁸⁷ ali s krilci,⁶⁸⁸ s trakasto fibulo,⁶⁸⁹ s certoškimi vrste V,⁶⁹⁰ ki govorijo, da so bile take spona na Dolenjskem v uporabi v kačasti in še v certoški stopnji. Dobre primerjave zanje najdemo v Hallstattu, kjer prav tako nastopajo v moški in ženski noši iz časa Ha D1.⁶⁹¹

Približno v istem času kot rombični primerki so se v dolenski skupnosti nosile pravokotno oblikovane železne spona,⁶⁹² kakor kažejo ohranjeni grobni sestavi. V žganih grobovih jo srečamo v Stični in Kosmatcu pri Preski,⁶⁹³ v glavnem pa v sklopu skeletnih grobov z orožjem. Zasledimo jih v kombinacijah s kačastimi fibulami s sedlastim lokom,⁶⁹⁴ s krilci⁶⁹⁵ ali s široko trakasto zanko,⁶⁹⁶ pa tudi s certoškimi vrst VIIa⁶⁹⁷ in XIII.⁶⁹⁸ V železnih rombičnih in pravokotnih pasnih sponah se ne nakazujejo niti kronološke niti spolne razlike, pač pa bi v njih lahko zaslutili statusne razlike, saj so rombične spona v glavnem vezane na skromne oprave, pravokotne pa se pojavljajo v bogatejših grobovih.

⁶⁸⁷ *Magdalenska gora-Preloge, gr. X/70.*

⁶⁸⁸ *Zagorica pri Čatežu-Martinov britof, skupek 14: Dular J. 2003, T. 39: 1,2.*

⁶⁸⁹ *Magdalenska gora-Preloge, gr. 2/73.*

⁶⁹⁰ *Magdalenska gora-Preloge, gr. 13/36, 13/69, Voselca, gr. 2/18.*

⁶⁹¹ Kromer 1959a, T. 1: 14, 5: 8, 9: 15, 12: 4, 32: 5, 35: 6, 130: 4, 133: 4, 148: 2, 160: 4, 165: 3, 228: 14, 229: 22, 237: 7, 243: 13,3, 245: 4, 248: 16, 250: 11, 260: 24; Hodson 1990, Fig. 12, 17, Tab. 8.

⁶⁹² *Brezje: Kromer 1959a, T. 4: 12; 12: 9; Boštanj: Guštin 1974b, T. 3: 21, 12: 13; Brusnice: Teržan 1974, T. 8: 12; Dolenjske Toplice: Teržan 1976, T. 49: 4; Kaplja vas: Dular J. 2003, T. 83: 4; Kladije nad Blanco: Dular J. 2003, T. 52: 4; Libna: Guštin 1976, T. 28: 5, 29: 6,10; Mokronog: neobjavljeno, NMS inv. št. P 1549, 10630; Novo mesto: Knez 1986, T. 19: 6, 38: 21; id. 1993, T. 7: 9, 22: 3; Križ 1997, T. 45: 5, 51: 10; Podzemelj: Barth 1969, T. 20: 1; Rihpovec: Dular J. 2003, T. 32: 1, 34: 8, 35: 1; Rovišče: Stare V. 1962–1963, T. 2: 8; Dular J. 2003, T. 73: 8; Stična: Gabrovec et al. 2006, T. 65: 1, 100: 1, 122: 3, 177: 171, 172; Suhadole: Dular J. 2003, T. 90: 9; Vače: Stare F. 1955a, T. 48: 8, 49: 1,4, 50: 1,2, 51: 1 in neobjavljeni primerki, NHMW inv. št. 6057, 8018; Veliki Vinji vrh (Šmarjeta): Stare V. 1973a, 16: 8, 46: 1; Dular A. 1991, T. 19: 7, 75: 15; Vinkov vrh: Stare V. 1964–1965, T. 3: 14, 11: 11; Volčje Njive: Gabrovec 1956, T. 9: 5, 18: 1, 23: 5; Zgornje Mladetiče: Dular J. 2003, T. 81: 5.*

⁶⁹³ *Stična, Gr. 48/110: Gabrovec et al. 2006, 83, T. 65: 1-7; Kosmatec pri Preski, gr. 9: Guštin 1974b, 90, T. 12: 10-13.*

⁶⁹⁴ *Rihpovec-Zelkova hosta, gr. 1: Dular J. 2003, T. 32: 1-5.*

⁶⁹⁵ *Magdalenska gora-Preloge, gr. 2/57; Stična, gr. 5/21–22: Gabrovec et al. 2006, T. 122; Libna-Glogovškova gom. I-1893/7: Guštin 1976, 39 (železna spona je omenjena, vendar ni ohranjena).*

⁶⁹⁶ *Magdalenska gora-Preloge, gr. 13/152.*

⁶⁹⁷ *Magdalenska gora-Preloge, gr. 2/60.*

⁶⁹⁸ *Dolenjske Toplice, gr. 7/8: Teržan 1976, T. 49; Novo mesto-Znančeve njive, gr. 2/9, Kapiteljska njiva, gr. 1/1: Knez 1986, T. 19; id. 1993, T. 7, 8: 1-5; Magdalenska gora-Laščik, gr. V/23.*

graves. In cremation graves, they were found in the above-mentioned grave at Magdalenska gora (Preloge, Gr. 13/10), but also at Stična, in Grave 48/30 with a so-called Sveta Lucija pithos and a goblet-like footed vessel,⁶⁸⁴ and at Podzemelj, in Grave 28/1 from Grm, which contained an urn in the form of a biconical jar with an everted rim and a bowl.⁶⁸⁵ The fact that these clasp appeared in the Stična phase is indicated by the graves from Gabrje below the Gorjanci Hills and Kavčev hrib near Suhadole in the Posavje Hills, where they were found in combination with a boat fibula,⁶⁸⁶ typical of the female costume. Most rhombic belt clasps, however, formed parts of male costumes with weapons or tools (awls and a whetstone). Chronologically most revealing are the grave groups with fibulae. The clasps were found in combination with serpentine fibulae with antennae⁶⁸⁷ or with wings,⁶⁸⁸ with a flat bow fibula,⁶⁸⁹ Type V Certosa fibulae,⁶⁹⁰ indicating that the rhombic clasps were in use in Dolenjska in the Serpentine and still in the Certosa phase. Close analogies for the clasps can be found at Hallstatt, where they also appear as part of the male and female costume from Ha D1.⁶⁹¹

The rhombic clasps were worn in Dolenjska at roughly the same period as the rectangular iron clasps,⁶⁹²

T. 5: 7, 40: 12, 50: 5, 54: 1; *Mokronog*: unpublished, NMS Inv. Nos. P 1547, 1548; *Podturn*: Dular J. 2003, T. 26: 1; *Podzemelj*: Barth 1969, T. 26: 9, 28: 4, 35: 7,8, 37: 8,9; *Stična*: Gabrovec et al. 2006, T. 25: 2; *Suhadole*: Dular J. 2003, T. 91: 6; *Vače*: Stare F. 1955a, T. 52: 2, 53: 1,2 and unpublished examples, NHMW Inv. Nos. 8019, 8124, 8083; *Veliki Vinji vrh (Šmarjeta)*: Stare V. 1973a, T. 16: 2,3,5, 67: 20; Dular A. 1991, T. 14: 4; *Volčje Njive*: Gabrovec 1956, T. 11: 2; *Zagorica pri Čatežu*: Dular J. 2003, T. 39: 1,2.

⁶⁸⁴ Gabrovec et al. 2006, 38, T. 25: 1-4.

⁶⁸⁵ Barth 1969, 135, T. 26: 7-9.

⁶⁸⁶ *Gabrje, Gr. 1/2; Suhadole- Kavčev hrib (flat cemetery), Gr. 5: Dular J. 2003, 159, 271, T. 4: 6-9, 91: 4-6.*

⁶⁸⁷ *Magdalenska gora-Preloge, Gr. X/70.*

⁶⁸⁸ *Zagorica pri Čatežu-Martinov britof, Set 14: Dular J. 2003, T. 39: 1,2.*

⁶⁸⁹ *Magdalenska gora-Preloge, Gr. 2/73.*

⁶⁹⁰ *Magdalenska gora-Preloge, Gr. 13/36, 13/69, Voselca, Gr. 2/18.*

⁶⁹¹ Kromer 1959a, T. 1: 14, 5: 8, 9: 15, 12: 4, 32: 5, 35: 6, 130: 4, 133: 4, 148: 2, 160: 4, 165: 3, 228: 14, 229: 22, 237: 7, 243: 13,3, 245: 4, 248: 16, 250: 11, 260: 24; Hodson 1990, Figs. 12, 17, Tab. 8.

⁶⁹² *Brezje: Kromer 1959a, T. 4: 12; 12: 9; Boštanj: Guštin 1974b, T. 3: 21, 12: 13; Brusnice: Teržan 1974, T. 8: 12; Dolenjske Toplice: Teržan 1976, T. 49: 4; Kaplja vas: Dular J. 2003, T. 83: 4; Kladije nad Blanco: Dular J. 2003, T. 52: 4; Libna: Guštin 1976, T. 28: 5, 29: 6,10; Mokronog: unpublished, NMS Inv. Nos. P 1549, 10630; Novo mesto: Knez 1986, T. 19: 6, 38: 21; id. 1993, T. 7: 9, 22: 3; Križ 1997, T. 45: 5, 51: 10; Podzemelj: Barth 1969, T. 20: 1; Rihpovec: Dular J. 2003, T. 32: 1, 34: 8, 35: 1; Rovišče: Stare V. 1962–1963, T. 2: 8; Dular J. 2003, T. 73: 8; Stična: Gabrovec et al. 2006, T. 65: 1, 100: 1, 122: 3, 177: 171, 172; Suhadole: Dular J. 2003, T. 90: 9; Vače: Stare F. 1955a, T. 48: 8, 49: 1,4, 50: 1,2, 51: 1 and unpublished examples,*

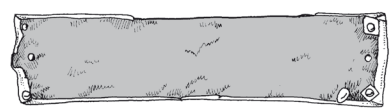
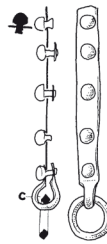
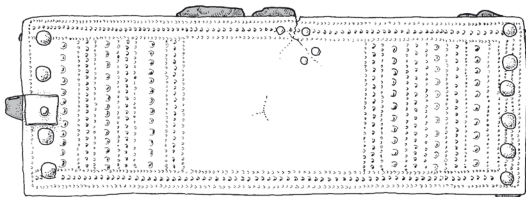
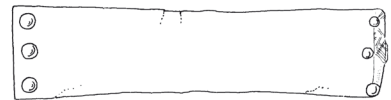
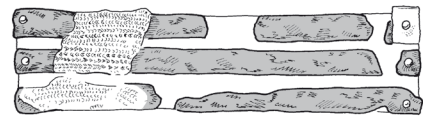
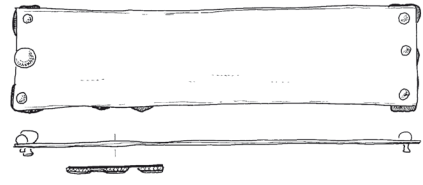
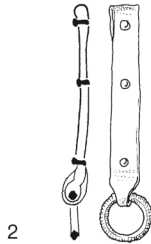
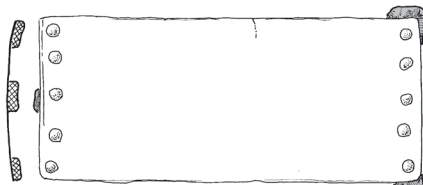
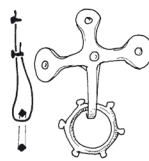
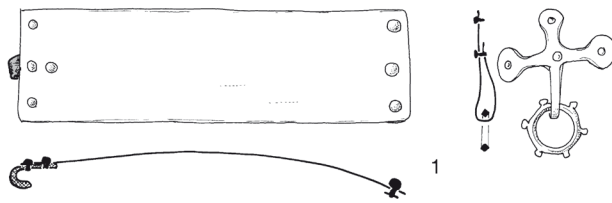

3

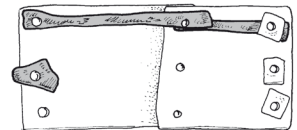
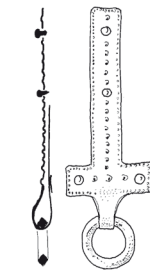
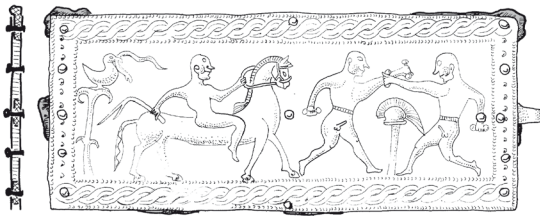

4



5

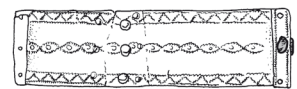
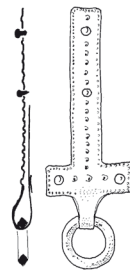

10

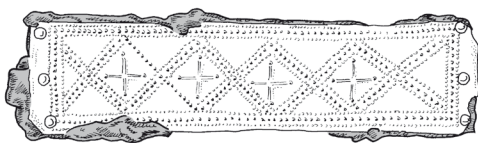

6

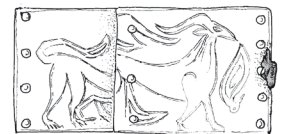

11

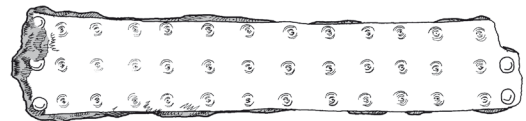

12

4.4.2 BRONASTE PRAVOKOTNE SPONE

Tipološke značilnosti. Pravokotne pasne spone, izdelane iz bronaste pločevine, so najštevilnejše. Delimo jih lahko na več različic. Prvo skupino predstavljajo primerki, ki so podloženi z železno ploščico (sl. 65: 3, 5, 6, 8, 12) ali z železnimi trakovi (sl. 65: 2, 4, 7, 9), nekatere pa imajo železen samo kavelj (sl. 65: 1, 10, 11).⁶⁹⁹ Drugo skupino predstavljajo pravokotne spone iz tanke bronaste pločevine, ki so povečini manj kakovostno izdelane (sl. 66). Ker večinoma niso bile utrjene s podlogo, so se pogosto lomile in so jih večkrat popravljali (sl. 66: 1, 7, 8, 11–13, 20).⁷⁰⁰

Lega in kontekst. Bronaste pravokotne pasne spone se na Magdalenski gori pojavljajo pretežno v skeletnih grobovih z orožjem (sl. 67 in sl. 68). Različice, ki so podložene z železno ploščico ali trakovi ali pa imajo železen kavelj, nastopajo v elitnih opravah, skupaj z dvogrebenastimi čeladami, čelado z narebreno kaloto in domnevno z negovsko čelado ter s servisi dragocenega posodja (sl. 65 in sl. 67: A–C). Med kronološko oprijemljivejše najdbe iz teh sestavov spadajo še kačaste fibule s sedlastim lokom, s krilci ali s široko trakasto zanko, pa trakaste fibule in samostrelne s pečatno nogo ter certoške vrst Ib in XIII.⁷⁰¹ Na fotografiji groba VII/39 je pravokotna spona jasno vidna, vendar je Hencken v tem sklopu ni objavil, pač pa jo je v risbi predstavil Gabrovec v študiji o dvogrebenastih čeladah.⁷⁰² Goldberg omenja pasno spono z zakovicami tudi med pridatki groba IV/3 s sestavljeno čelado, kjer je prav tako pogrešana; na Magdalenski gori je to najstarejši grobni sestav s tovrstno spono.

Bronaste pravokotne spone brez podloge (sl. 66 in sl. 68) so različnih proporcij in le poredkoma nastopajo v elitnih nošah, med katere spadata konjeniška grobova

⁶⁹⁹ Hencken 1978; Fig. 72o, 88e, 129a, 276a, 343g,h, 363a; Tecco Hvala/Dular/Kocuvan 2004, T. 24: 2,3, 35: 2, 41: 1, 51: 2,3, 53: 1, 74B: 1, 84: 2, 93C: 1, 103A: 1, 108: 2, 117B: 4, 136A: 1, 156: 1,3,4, 157: 4.

⁷⁰⁰ Hencken 1978, Fig. 26f, 32e,f, 37s, 41b, 63f, 85r, 92d,e, 112n, 130f, 140g,k,m, 167e, 168, 191a,d, 212c,d, 217, 223k, 258, 265g,h, 280a, 281a, 293a, 299h, 316, 317a, 332a, 335a, 337d,i, 340, 341i, 342, 360i, 361d, 364a; Tecco Hvala/Dular/Kocuvan 2004, T. 16: 16, 39A: 1, 45: 7, 55A: 1, 57A: 1, 60B: 1, 64: 1, 67A: 1, 71C: 1, 73B: 1, 82B: 4, 92B: 1, 111A: 1, 114B: 1, 135: 7, 156: 2, 157: 3, 158: 1.

⁷⁰¹ Preloge, gr. 2/13, 2/38, 2/46, 2/57, 2/58, 13/119, 13/155, 13/153, VII/39, IV/32.

⁷⁰² Gabrovec 1962–1963, T. 18: 1; Hencken 1978, Fig. 258, 259; Weiss 1999, Abb. 63.

as evidenced by the preserved grave groups. They were found in cremation graves at Stična and Kosmatec near Preska,⁶⁹³ but mostly in inhumation graves with weapons. They appeared in combinations with serpentine fibulae with a saddle-shaped bow,⁶⁹⁴ with wings⁶⁹⁵ or a band bow curved into a loop,⁶⁹⁶ as well as with Certosa fibulae of Types VIIa⁶⁹⁷ and XIII.⁶⁹⁸ Neither the rhombic nor the rectangular clasps indicate differences in date or sex, while there are discernible differences in status, since the rhombic clasps are mostly tied to a poorer costume, while rectangular examples are attributed to a richer costume.

4.4.2 BRONZE RECTANGULAR CLASPS

Typological characteristics. The most numerous represented are the rectangular belt clasps made of sheet bronze. They appear in several variants. The first shows the bronze sheet reinforced by an iron plate (fig. 65: 3, 5, 6, 8, 12) or iron bands (fig. 65: 2, 4, 7, 9), while the only iron element in some clasps is the hook (fig. 65: 1, 10, 11).⁶⁹⁹ The second group is represented by rectangular clasps of thin bronze sheet, which are mostly less well made (fig. 66). Not being reinforced by a plate, they were prone to breaking and consequentially often repaired (fig. 66: 1, 7, 8, 11–13, 20).⁷⁰⁰

NHMW Inv. Nos. 6057, 8018; *Veliki Vinji vrh* (Šmarjeta): Stare V. 1973a, 16: 8, 46: 1; Dular A. 1991, T. 19: 7, 75: 15; *Vinkov vrh*: Stare V. 1964–1965, T. 3: 14, 11: 11; *Volčje Njive*: Gabrovec 1956, T. 9: 5, 18: 1, 23: 5; *Zgornje Mladetiče*: Dular J. 2003, T. 81: 5.

⁶⁹³ *Stična*, Gr. 48/110: Gabrovec et al. 2006, 83, T. 65: 1–7; *Kosmatec near Preska*, Gr. 9: Guštin 1974b, 90, T. 12: 10–13.

⁶⁹⁴ *Rihpovec-Zelkova hosta*, Gr. 1: Dular J. 2003, T. 32: 1–5.

⁶⁹⁵ *Magdalenska gora-Preloge*, Gr. 2/57; *Stična*, gr. 5/21–22: Gabrovec et al. 2006, T. 122; *Libna-Glogovšek Tum. I-1893/7*: Guštin 1976, 39 (the iron clasp is not preserved).

⁶⁹⁶ *Magdalenska gora-Preloge*, Gr. 13/152.

⁶⁹⁷ *Magdalenska gora-Preloge*, Gr. 2/60.

⁶⁹⁸ *Dolenjske Toplice*, Gr. 7/8: Teržan 1976, T. 49; *Novo mesto-Znančeve njive*, Gr. 2/9, *Kapiteljska njiva*, Gr. 1/1: Knez 1986, T. 19; *id.* 1993, T. 7, 8: 1–5; *Magdalenska gora-Laščik*, Gr. V/23.

⁶⁹⁹ Hencken 1978; Figs. 72o, 88e, 129a, 276a, 343g,h, 363a; Tecco Hvala/Dular/Kocuvan 2004, T. 24: 2,3, 35: 2, 41: 1, 51: 2,3, 53: 1, 74B: 1, 84: 2, 93C: 1, 103A: 1, 108: 2, 117B: 4, 136A: 1, 156: 1,3,4, 157: 4.

⁷⁰⁰ Hencken 1978, Figs. 26f, 32e,f, 37s, 41b, 63f, 85r, 92d,e, 112n, 130f, 140g,k,m, 167e, 168, 191a,d, 212c,d, 217, 223k, 258, 265g,h, 280a, 281a, 293a, 299h, 316, 317a, 332a, 335a, 337d,i, 340, 341i, 342, 360i, 361d, 364a; Tecco Hvala/Dular/Kocuvan 2004, T. 16: 16, 39A: 1, 45: 7, 55A: 1, 57A: 1,

Sl. 65: Bronaste pasne spone z železno podlogo ali z železnim kavljem z Magdalenske gore. M. = 1:4.

Fig. 65: Bronze belt clasps with iron reinforcement or with iron hook from Magdalenska gora. Scale = 1:4.

1 – Preloge, gr. 13/119; 2 – Preloge, gr. 13/153; 3 – Preloge, gr. 13/55; 4 – Preloge, gr. 2/46; 5, 6 – Preloge, gr. 2/13; 7 – Preloge, gr. 13/29; 8 – Preloge, gr. IV/47; 9 – Preloge, gr. X/52; 10 – Preloge, Tum. X; 11 – Preloge, gr. 2/58; 12 – Preloge, gr. 2/57.

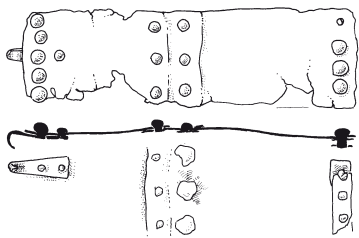

1

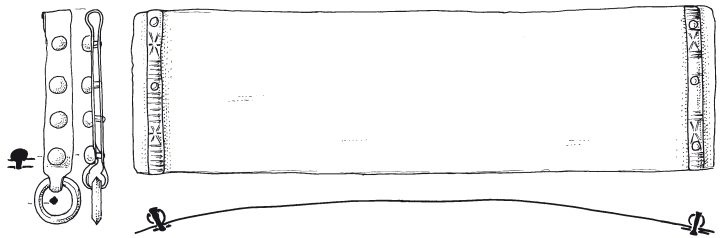

2

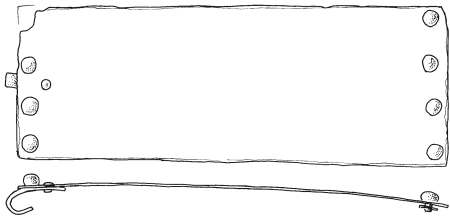

3

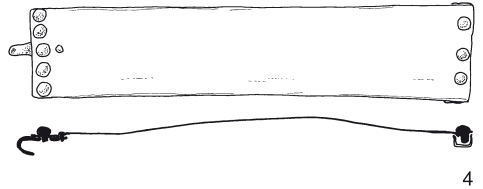

4

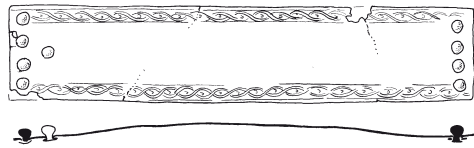

5

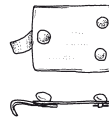
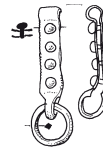

6

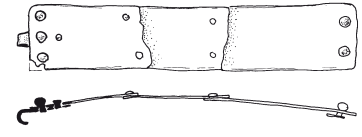

7

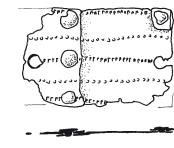

8

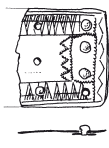

9

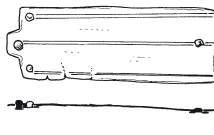

10

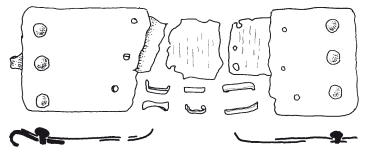

11

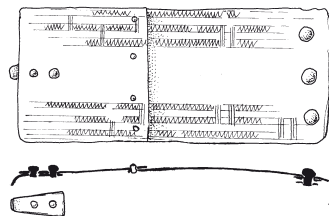

12

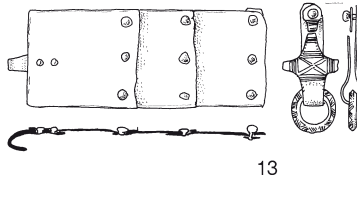

13

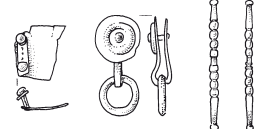

14

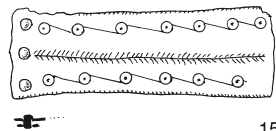

15

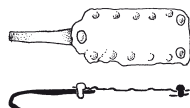

16

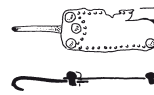

17

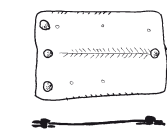
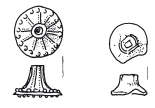

18



19

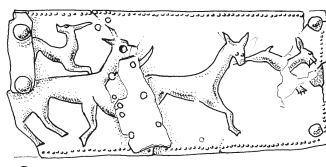

20

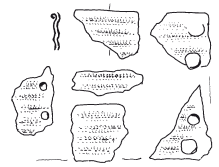

21

Gom. / Gr. Tum. / Gr.	Pokop / Burial rite	Spol / Starost Sex / Age	Tip pasnih spon / Type of belts	Št. pasnih spon / No. of belts	Pasni okovi / Belt attachments	Obeski / Pendants	Fibule / Fibulae	Narokvice / Armrings	Čelada / Helmet	Sekire / Axes	Sulice / Spears	Puščice / Arrows	Noži / Knives	Meč / Sword	Žezlo / Mace	Raženj / Spilt	Šilo / Awl	Brus / Whetstone	Konjska oprema / Horse gear	Lončenina / Pottery	Bronasto posodje / Bronze vessels
P VI/17	S	M	D*	1	br					1	2										
P 2/42	S	M	D	1	br					1	2										
P 2/47	S	M	D	1	br			1		1	2		2								2
P VIII/6	S	M	D	1						1	2		1								
P X/46	S	M	D	1	br	Pb				1	2		1								
P X/51	S	M	D	1+1	br		2			1	2										
P 2/j	S	M	?	1	br		2	2 Pb		1	2		1						x		1
P 13/84	S	M	D	1	br					1	1		1								
P X/25	S	M	D	1	br	2		1 Pb		1			1								
P II/16	S	M	D	1	br					1			1								
P X/2	S	M	D*?	1									1								1
P X/44	S	M	D	1	br								1								
P 13/69	S	M	D*	1+1*	br		1						1								1
P 2/74	S	M	D	1	br		2			1											1
P VII/44	S	M	D	1	br	1	2			1											
L V/6-7	S	M	D	1+1*	br		2+2		1		2+2		1			2			x		3
L V/29	S	M+M	D+D*	1+1	br			1	1		4+2		1	1	1			1	x	2	4
L V/26a	S	M	D	1							2		1	1		?	1				1
P IV/52	?	M	D	1	Fe						2		1								
P VII/51	?	M	D	1		1					1		1								
P VIII/5	S	M	D	1	br						1		1								
P 13/5	S	M	D*	1	br	1					1	x									
P 13/20	S	M	D	1	br						1										
P 2/59	S	M	D	1	br						1										2
P 13/28	S	M	D	1	br						1										
L V/47	?	M	D	1	br		1				1										
V 2/11	S	?	D	1	br		4														1
P 13/53	S	?	D	1	br		2	1													1
P 2/62	S	M	D	1			2														1
P X/77	S	?	D	1	br		2														
P X/41	S	?	D	1	br																
P 13/124	S	?	D	1	br																
P 13/137	S	?	D	1	br												1				
P VI/43	S	?	D	1																	

Sl. 68: Struktura pridatkov v grobovih z bronastimi pravokotnimi pasnimi sponami na Magdalenski gori.

Fig. 68: Structure of goods in the graves with bronze rectangular belt clasps at Magdalenska gora.

* = okrašeni primerki / decorated examples.

ki je poleg pasne spona vseboval še zlomljen železni meč z zlatim okraskom, sulični osti, nož ter nekakšno dolgo iglo ali konico bodala, ki ni objavljena. Po Pečnikovem opisu naj bi "širok bronast pas iz pločevine" spadal tudi v konjeniški grob 2/j s Prelog, katerega pridatki v zbirki Narodnega muzeja niso zabeleženi kot grobna celota; prepoznali smo lahko le nekatere predmete (dve svinčeni narokvici ter konjsko opremo in okrasje), ne pa tudi pasne spona, dveh fibul, situle, uhate sekire in drugega orožja. V popisu najdb iz groba VII/44 na Prelogah Goldberg govori o "železni kopači" (morda je šlo za sekiro z enostranskimi plavutmi, ki ima ukrivljeno rezilo), medtem ko je objavljena tulasta sekira z ušescem in bronasto žico za pričvrstitev na leseno toporišče. V opravah z bronastimi pravokotnimi sponami zasledimo poleg orožja še razne vrste fibul (kačasto s široko trakasto zanko, trortasto vrste VII po Ogrinovi, dolgonožno z mrežastim okrasom na loku, samostrelne z naprej gledajočo konjsko glavico ter certoške vrst V, XIII in X),⁷⁰³ ki so značilne za mlajše halštatsko obdobje, ter bronaste spiralne ali svinčene narokvice,⁷⁰⁴ ki se pojavljajo v moški noši v certoški in negovski stopnji.

Ornamentika na pasnih sponah

Bronaste pravokotne spona so pogosto okrašene. Na primerkih, ki so podloženi z železno ploščico ali trakovi (sl. 65: 3–6, 10, 12), zasledimo iztolčen okras v dovršeni kompoziciji, medtem ko se na sponah brez železne podlage povečini pojavlja vrezan ali punciran geometrijski ornament (sl. 66: 5, 8–10, 12, 15–17, 18, 19).

O dekoracijah na pasnih sponah z območja Dolenjske je pisal že France Stare leta 1952, ko gradivo iz dolenjskih grobišč zvečine ni bilo objavljeno. Izbrane primerke z Magdalenske gore, Vač, iz Stične, Zagorja, Brezja in z Mosta na Soči je stilno razčlenil in poskušal ugotoviti glavne razvojne tendence. Glede na strukturo in kompozicijo ornamenta jih je razdelil v tri skupine. Za prvo naj bi bil značilen horizontalno tekoč in ponavljajoč se motiv, za drugo tekoč in zaključen motiv, za tretjo pa vertikalno simetričen motiv. Predpostavljal je, da si te tri stilistične skupine kronološko sledijo po navedenem vrstnem redu.⁷⁰⁵

V geometrijskem okrasu na dolenjskih halštatskih primerkih⁷⁰⁶ bi lahko prepoznali žarnogrobiščno ma-

⁷⁰³ Laščik, gr. V/6–7a–7, Preloge, gr. 2/62, 13/53, 13/55, 13/69, IV/25, VII/44, X/51, X/77; Voselca, gr. 2/11. O dveh fibulah, spetih z verižico, poroča Pečnik v zvezi z grobom 2/74 s Prelog, vendar niso ohranjene.

⁷⁰⁴ Laščik, gr. V/29, Preloge, gr. 2/j, 2/47, X/25.

⁷⁰⁵ Stare F. 1952, 173 ss.

⁷⁰⁶ Brezje: Kromer 1959a, T. 24: 9, 37: 1; Dobrnič: Stare V. 1973b, T. 11: 2; Dolenjske Toplice: Teržan 1976, T. 25: 10; Kozlevec pri Stanu: Dular J. 2003, T. 5: 7; Libna: Guštin 1976, T. 8: 1, 61: 8, 78: 11; Magdalenska gora: Stare F. 1952, risba 2, 3; Hencken 1978, Fig. 32e, 129a, 217, 299h; Tecco Hvala/

65 and 67: A–C). Chronologically revealing finds further include serpentine fibulae with a saddle-shaped bow, with wings or a band bow curved into a loop, flat bow fibulae, crossbow fibulae with a stamped foot and Types Ib and XIII Certosa fibulae.⁷⁰¹ The photo of Grave VII/39 clearly shows a rectangular clasp, though Hencken did not include it in the publication of the grave group. It was, however, published in drawing by Gabrovec in his study on double-crested helmets.⁷⁰² Another belt clasp with rivets is mentioned by Goldberg among the goods in Grave IV/3, which is also missing. This grave contained a composite helmet and represents the earliest context with a rectangular clasp at Magdalenska gora.

Bronze rectangular belt clasps without reinforcement (figs. 66 and 68) vary in proportions and have only rarely formed parts of the elite costume; the latter include horsemen Graves V/6–7a–7 and V/29 at Laščik. The discrepancy between the published groups of these two graves and Goldberg's description has been pointed out already when discussing helmets. According to Goldberg, Grave V/6–7a–7 revealed a rectangular belt clasp and an openwork clasp in the shape of a bird (fig. 69: 4), while the helmet was supposedly of the double-crested type. Grave V/29 with two Negova helmets and a sword, on the other hand, reportedly contained only two clasps (one broken with figural decoration and the other undecorated), while the publication of the grave lists three (fig. 66: 20). Ranking among the rich groups is Grave V/26a from the same tumulus, which contained a belt clasp and a broken iron sword with decorations in gold, two spearheads, a knife and a sort of a long pin or dagger point, the latter not published. Pečnik's notes reveal that a "wide bronze band of sheet metal" was found in horseman's Grave 2/j at Preloge, the goods of which are not inventoried as a group in the National Museum in Ljubljana; only some of the items were identified (two lead armlets as well as horse gear and adornments), while the belt clasp, two fibulae, a situla, a shaft-hole axe and other weapons were not. Listing the finds in Grave VII/44 at Preloge, Goldberg mentioned an "iron hoe" (possibly a one-sided winged axe with a curved blade), while the publications presents a socketed axe with a loop and a bronze wire for attachment to a wooden haft. The costume with bronze rectangular belt clasps includes weapons, various types of fibulae (serpentine fibulae, three-knobbed fibula of Type VII after Ogrin, fibula with a long foot and reticular decoration on the bow, crossbow fibulae with a forward-looking horse's head, Types V, XIII and X Certosa fibulae),⁷⁰³ characteristic of the Late

⁷⁰¹ Preloge, Gr. 2/13, 2/38, 2/46, 2/57, 2/58, 13/119, 13/55, 13/153, VII/39, IV/32.

⁷⁰² Gabrovec 1962–1963, T. 18: 1; Hencken 1978, Figs. 258, 259; Weiss 1999, Abb. 63.

⁷⁰³ Laščik, Gr. V/6–7a–7, Preloge, Gr. 2/62, 13/53, 13/55, 13/69, IV/25, VII/44, X/51, X/77; Voselca, Gr. 2/11. According to Pečnik, two fibulae tied with a chain were found in Grave 2/74 at Preloge, now missing.

niro; narejen je z navadnim ali tremoliranim vrezom, punciranjem ali iztolčenimi pikami in bunčicami. Izraz te tradicije predstavlja tudi iztolčen motiv rač in koncentričnih krožcev, kakršen je menda krasil izgubljeni primerek iz groba 13/69 s Prelog na Magdalenski gori iz časa certoške stopnje. Enak okras ima bronasta situla, ki pripada rekonstruirani grobni celoti 2/a s Prelog, v katero spada še druga situla, okrašena s štirimi figuralnimi frizi.⁷⁰⁷ Motiv rač in koncentričnih krožcev zasledimo tudi na bronasti situli iz Malenškove gomile v Novem mestu, v grobu 3, ki je prav tako datiran v certoško stopnjo.⁷⁰⁸ Razen tega krasi nekatere pasne sponje z Vač⁷⁰⁹ ter Mosta na Soči, kjer je bila najdena skupaj z enako ornamentirano bronasto situlo ter kačastima fibulama.⁷¹⁰

Nekateri dolenski primerki pravokotnih pasnih spon so okrašeni s figuralnimi prizori, ki upodabljajo krilata fantazijska bitja (*sl.* 65: 5) ali eksotične živali (*sl.* 65: 11)⁷¹¹ ter motive, kot so rokoborba in jezdec (*sl.* 65: 4),⁷¹² dvoboj konjenikov s kopji,⁷¹³ spopad živali,⁷¹⁴ lov⁷¹⁵ in ribolov,⁷¹⁶ pa sprevide⁷¹⁷ in živali iz domačega okolja⁷¹⁸ ter erotični prizor.⁷¹⁹ Magdalenskogorske figuralno okrašene sponje so med najboljše ohranjenimi.

Dular/Kocuvan 2004, T. 51: 2, 93C: 1, 136A: 1; *Novo mesto*: Knez 1986, T. 1: 20, 8: 5, 13: 11,12, 15: 1; *Podturn-Zadnja hosta*: Dular J. 2003, T. 24: 2; *Rovišče*: Stare V. 1962–1963, T. 9: 15; Dular J. 2003, T. 79: 9; *Stična*: Stare F. 1952, risba 6; Wells 1981, Fig. 32a, 70c, 189f; Gabrovec et al. 2006, T. 14: 3, 26: 10, 11, 44: 3, 80: 1, 95: 1, 116: 1, 137: 13, 165: 3, 177: 170; *Vače*: Stare F. 1952, risba 5, T. 1: 1-3 in neobjavljen primerek, NHMW inv. št. 7983, 7984; Stare F. 1955a, T. 40: 10, 41: 1,3,4; *Veliki Vinji vrh (Šmarjeta)*: Stare V. 1973a, T. 15: 1-5,11, 66: 22; Dular A. 1991, T. 23: 5, 34: 27, 75: 16; *Vinkov Vrh*: Stare V. 1964–1965, T. 4: 1, 16: 6; *Vintarjevec*: Stare F. 1953, T. 6: 1; *Volčje Njive*: Gabrovec 1956, T. 18: 2; *Zagorje*: Gabrovec 1966b, T. 8: 5.

⁷⁰⁷ Tecco Hvala/Dular/Kocuvan 2004, T. 7: 5, pril. 7.

⁷⁰⁸ Guštin/Teržan 1975, 190, T. 4: 1.

⁷⁰⁹ Stare F. 1952, T. 1: 4; id. 1955a, T. 42: 1 ter neobjavljeni primerki, NHMW inv. št. 8173, 40146.

⁷¹⁰ Marchesetti 1993, 106, T. 3: 4, 26: 1.

⁷¹¹ *Magdalenska gora*: Szombathy 1894, 231, Abb. 280; Stare F. 1952, T. 2: 1, 6: 2; Tecco Hvala/Dular/Kocuvan 2004, T. 24: 3, 53: 1; *Vače*: Stare F. 1955a, T. 44: 1.

⁷¹² *Magdalenska gora*: Stare F. 1952, T. 6: 1; Tecco Hvala/Dular/Kocuvan 2004, T. 41: 1, pril. 12.

⁷¹³ *Vače*: Stare F. 1952, T. 3.

⁷¹⁴ *Vače*: Stare F. 1952, T. 5; id. 1955a, T. 45: 1.

⁷¹⁵ *Molnik*: Puš 1991, 48 s, hrbtna platnica; *Zagorje*: Stare F. 1952, T. 4; Gabrovec 1966b, T. 7: 3.

⁷¹⁶ *Novo mesto-Kapiteljska njiva*: Križ 1997, pril. 4; Križ et al. 2009, 135.

⁷¹⁷ *Stična*: Lucke/Frey 1962, T. 33; Geupel 1972, Fig. 1; Gabrovec 1978, sl. 8: 3,4.

⁷¹⁸ *Brezje*: Kromer 1959a, T. 36: 5; Barth 1999, Abb. 2; *Dolenske Toplice*: Teržan 1976, T. 69: 6; *Stična*: Gabrovec et al. 2006, T. 62: 2; *Vače*: Stare F. 1955a, T. 44: 1; Lucke/Frey 1962, T. 53.

⁷¹⁹ *Brezje*: Stare F. 1952, T. 2: 3; Kromer 1959a, T. 1: 1; *Novo mesto-Kapiteljska njiva*: Križ 1997, pril. 4.

Hallstatt period. They also included bronze spiral or lead armllets,⁷⁰⁴ which form parts of the male costume in the Certosa and Negova phases.

Decoration on belt clasps

The bronze rectangular belt clasps are often decorated. The clasps reinforced by iron plates or bands (*fig.* 65: 3–6, 10, 12) show embossed, perfectly composed designs, while the clasps without the iron reinforcement mostly bear incised or punched geometric designs (*fig.* 66: 5, 8–10, 12, 15–17, 18, 19).

The decoration on the belt clasps from Dolenska was already discussed by Stare in 1952. At that time, the material from the sites in Dolenska has not yet been published. He divided the selected clasps from Magdalenska gora, Vače, Stična, Zagorje, Brezje and Most na Soči according to style and attempted to establish the main points of development. Based on the structure and composition of the decorative design, he established three groups. The first was characterized by a horizontally running and repeating motif, the second by a running and enclosed motif and the third by a vertically symmetric motif. He presumed the three stylistic groups to follow one another chronologically according to the stated order.⁷⁰⁵

The geometric designs on the Hallstatt clasps from Dolenska⁷⁰⁶ reveal the Urnfield culture tradition. The decoration consists of simple or tremolo incisions, punching and embossed dots. An expression of this tradition could also be seen in the embossed ducks and concentric circles, presumably decorating the now lost clasp from Grave 13/69 at Preloge dated to the Certosa phase. The same decoration can be found on a bronze situla that forms part of the reconstructed group of Grave 2/a at Preloge, which contained another bronze situla, decorated

⁷⁰⁴ *Laščik*, Gr. V/29, Preloge, Gr. 2/j, 2/47, X/25.

⁷⁰⁵ Stare F. 1952, 173 ff.

⁷⁰⁶ *Brezje*: Kromer 1959a, T. 24: 9, 37: 1; *Dobrnič*: Stare V. 1973b, T. 11: 2; *Dolenske Toplice*: Teržan 1976, T. 25: 10; *Kozlevec near Stan*: Dular J. 2003, T. 5: 7; *Libna*: Guštin 1976, T. 8: 1, 61: 8, 78: 11; *Magdalenska gora*: Stare F. 1952, Figs. 2, 3; Hencken 1978, Figs. 32e, 129a, 217, 299h; Tecco Hvala/Dular/Kocuvan 2004, T. 51: 2, 93C: 1, 136A: 1; *Novo mesto*: Knez 1986, T. 1: 20, 8: 5, 13: 11,12, 15: 1; *Podturn-Zadnja hosta*: Dular J. 2003, T. 24: 2; *Rovišče*: Stare V. 1962–1963, T. 9: 15; Dular J. 2003, T. 79: 9; *Stična*: Stare F. 1952, Fig. 6; Wells 1981, Figs. 32a, 70c, 189f; Gabrovec et al. 2006, T. 14: 3, 26: 10, 11, 44: 3, 80: 1, 95: 1, 116: 1, 137: 13, 165: 3, 177: 170; *Vače*: Stare F. 1952, Fig. 5, T. 1: 1-3 and unpublished examples, NHMW Inv. Nos. 7983, 7984; Stare F. 1955a, T. 40: 10, 41: 1,3,4; *Veliki Vinji vrh (Šmarjeta)*: Stare V. 1973a, T. 15: 1-5,11, 66: 22; Dular A. 1991, T. 23: 5, 34: 27, 75: 16; *Vinkov Vrh*: Stare V. 1964–1965, T. 4: 1, 16: 6; *Vintarjevec*: Stare F. 1953, T. 6: 1; *Volčje Njive*: Gabrovec 1956, T. 18: 2; *Zagorje*: Gabrovec 1966b, T. 8: 5.

Mednje spada tudi najstarejši tak izdelek, ki ga krasi vgravirana podoba leva in kozoroga ali morda antilope z mrtvo ptico v gobcu (*sl. 65: 11*), najden v grobu 2/58 s Prelog, ki ga lahko po trakastih fibulah datiramo na konec kačaste stopnje ali na začetek certoške stopnje. Vsi drugi figuralno okrašeni primerki spadajo v čas certoške stopnje.⁷²⁰ Na Molniku je omenjena spona pripadala žganemu grobu v gomili,⁷²¹ v ostalih primerih gre za skeletne grobove. Ikonografski motivi na pasnih sponah sodijo v zakladnico situlske umetnosti in so obravnavani v številnih študijah, ki se ukvarjajo s to tematiko.⁷²² Obdajajo jih okrasni okviri, izdelani v iztolčeni, vrezani ali puncirani tehniki. Obroba v obliki prepleta oz. pletenice se pojavlja na figuralnih sponah z Magdalenske gore (*sl. 65: 4*), Vač, Molnika, iz Stične in Brezja; okvir s pletenico brez osrednjega motiva (*sl. 66: 5*) zasledimo na nekaterih kosih z Magdalenske gore,⁷²³ Vač⁷²⁴ in Mosta na Soči.⁷²⁵ Pletenica oz. t. i. *guillochis* je značilna za orientalizirajoči stil, pojavlja se na etruščanskih arhitektonskih elementih⁷²⁶ in kamnitih stelah,⁷²⁷ na slonokoščenih predmetih⁷²⁸ ter zlatih in bronastih izdelkih iz 7. in 6. st. pr. n. št.⁷²⁹ Zasledimo jo na situli iz histrskega Nezakcija,⁷³⁰ na pasnih sponah iz estenskih grobov iz časa Este IIID2 po Peroniju (= III-pozno po Freyu)⁷³¹ in z Mostu na Soči v stopnji Sv. Lucija IIb (= stopnja certoških fibul na Dolenjskem).⁷³²

⁷²⁰ *Magdalenska gora-Preloge, gr. 2/13, 2/46; Novo mesto-Kapiteljska njiva, gr. 3/12*; Križ 1997, T. 38, 39, pril. 3, 4; *Stična VI/30, 48/104*; Gabrovec et al. 2006, sl. 71, T. 61, 62; *Dolenjske Toplice, gr. 11/21*; Teržan 1976, T. 69; *Brezje, gr. 13/8*; Kromer 1959a, T. 36, 37: 1-4; *Molnik, gr. 3/10*; Puš 1991, hrbtna platnica; *Zagorje-Milačeva hiša*: Gabrovec 1966b, 24 s, T. 5: 8-10, 6: 1-3; 7: 3, 8: 1,3,4.

⁷²¹ Puš 1991, 45 (tloris gomile), 48 s.

⁷²² *Umetnost alpskih Ilirov in Venetov* 1962; Lucke/Frey 1962; Frey 1969; Bonfante 1981; Teržan 1997; ead. 1998; ead. 2001a; ead. 2004b; Turk 2005 z navedbo starejše literature; Gleirscher 2009 idr.

⁷²³ Hencken 1978, Fig. 363a; Tecco Hvala/Dular/Kocuvan 2004, T. 92B: 1.

⁷²⁴ Stare F. 1952, T. 1: 5; id. 1955a: T. 44: 2.

⁷²⁵ Teržan/Lo Schiavo/Trampuž-Orel 1984, T. 142A: 4.

⁷²⁶ Npr. na ploščah, t. i. *Lastre Boccanera iz Cerveterija*, na zaključnih elementih grobnice v *Tarquiniiji*: Bianchi Bandinelli/Guiliano 1973 (2000), Fig. 181, 207; na ploščah iz palače v *Poggio Civitate (Murlo)*: Bonfante 1981, Fig. 31-34 itd.

⁷²⁷ *Vulci*: Frey 1969, 64, Texttaf. D: 3.

⁷²⁸ Npr. iz *grobnice Barberini (Praeneste-Palestrina)* ali *Montefortini (Comeana)*: Torelli (ur.) 2000, 473 s, Kat. št. 119 s citirano literaturo.

⁷²⁹ Npr. zlata pektoralna ter zlati zapestnici s sfigami in na bronastem ščitu iz *Tarquiniije*: Hencken 1968a, Fig. 385B, 389-391; na bronasti amfori iz *Orvieta* ali ogledalu iz *Praeneste (Palestrina)*: Bonfante 1981, Fig. 55, 74 s citirano literaturo; na situli *Providence*: Lucke/Frey 1962, Beil 1.

⁷³⁰ Mihovilić 2001, 100 s, sl. 94, T. 15: 9.

⁷³¹ *Casa di Ricovero, gr. 219, Villa Benvenuti, gr. 94*: Chieco Bianchi/Calzavara Capuis 1985, T. 86: 14, 87: 22, 149b.

⁷³² Teržan/Lo Schiavo/Trampuž-Orel 1984, T. 142A.

with four figural friezes.⁷⁰⁷ The motif of ducks and concentric circles can further be observed on the bronze situla from Grave 3 of the Malenšek tumulus in Novo mesto, also dated to the Certosa phase.⁷⁰⁸ It decorates several belt clasps from Vače⁷⁰⁹ and Most na Soči, where the clasps were found together with a bronze situla bearing the same decoration and two serpentine fibulae.⁷¹⁰

Some rectangular belt clasps from Dolenjska are decorated with figural scenes. These include winged fantastical creatures (*fig. 65: 5*) or exotic animals (*fig. 65: 11*),⁷¹¹ but also wrestling and riding scenes (*fig. 65: 4*),⁷¹² duels of javelin-bearing horsemen,⁷¹³ animal fights,⁷¹⁴ hunting⁷¹⁵ and fishing,⁷¹⁶ processions,⁷¹⁷ animals from a local environment,⁷¹⁸ as well as an erotic scene.⁷¹⁹ The figurally decorated clasps from Magdalenska gora are among the best preserved ones and include the earliest such clasp with an engraved lion and ibex or possibly an antelope with a dead bird in its mouth (*fig. 65: 11*). This clasp was found in Grave 2/58 at Preloge, which could be dated to the end of the Serpentine Fibulae or the beginning of the Certosa phase based on the flat bow fibulae. All other figurally decorated clasps date to the Certosa phase.⁷²⁰ The clasp from Molnik was found in a cremation burial into a tumulus,⁷²¹ while other decorated clasps were found in inhumations. The motifs on belt clasps reveal the iconography of the situla art and

⁷⁰⁷ Tecco Hvala/Dular/Kocuvan 2004, T. 7: 5, Beil. 7.

⁷⁰⁸ Guštin/Teržan 1975, 190, T. 4: 1.

⁷⁰⁹ Stare F. 1952, T. 1: 4; id. 1955a, T. 42: 1, and unpublished examples, NHMW Inv. Nos. 8173, 40146.

⁷¹⁰ Marchesetti 1993, 106, T. 3: 4, 26: 1.

⁷¹¹ *Magdalenska gora*: Szombathy 1894, 231, Abb. 280; Stare F. 1952, T. 2: 1, 6: 2; Tecco Hvala/Dular/Kocuvan 2004, T. 24: 3, 53: 1; *Vače*: Stare F. 1955a, T. 44: 1.

⁷¹² *Magdalenska gora*: Stare F. 1952, T. 6: 1; Tecco Hvala/Dular/Kocuvan 2004, T. 41: 1, Beil. 12.

⁷¹³ *Vače*: Stare F. 1952, T. 3.

⁷¹⁴ *Vače*: Stare F. 1952, T. 5; id. 1955a, T. 45: 1.

⁷¹⁵ *Molnik*: Puš 1991, 48 f, on the back cover; *Zagorje*: Stare F. 1952, T. 4; Gabrovec 1966b, T. 7: 3.

⁷¹⁶ *Novo mesto-Kapiteljska njiva*: Križ 1997, App. 4; Križ et al. 2009, 135.

⁷¹⁷ *Stična*: Lucke/Frey 1962, T. 33; Geupel 1972, Fig. 1; Gabrovec 1978, Fig. 8: 3,4.

⁷¹⁸ *Brezje*: Kromer 1959a, T. 36: 5; Barth 1999, Abb. 2; *Dolenjske Toplice*: Teržan 1976, T. 69: 6; *Stična*: Gabrovec et al. 2006, T. 62: 2; *Vače*: Stare F. 1955a, T. 44: 1; Lucke/Frey 1962, T. 53.

⁷¹⁹ *Brezje*: Stare F. 1952, T. 2: 3; Kromer 1959a, T. 1: 1; *Novo mesto-Kapiteljska njiva*: Križ 1997, App. 4.

⁷²⁰ *Magdalenska gora-Preloge, Gr. 2/13, 2/46; Novo mesto-Kapiteljska njiva, Gr. 3/12*; Križ 1997, T. 38, 39, App. 3, 4; *Stična VI/30, 48/104*; Gabrovec et al. 2006, Abb. 71, T. 61, 62; *Dolenjske Toplice, Gr. 11/21*; Teržan 1976, T. 69; *Brezje, Gr. 13/8*; Kromer 1959a, T. 36, 37: 1-4; *Molnik, Gr. 3/10*; Puš 1991, on the back cover; *Zagorje-Milačeva hiša*: Gabrovec 1966b, 24 f, T. 5: 8-10, 6: 1-3; 7: 3, 8: 1,3,4.

⁷²¹ Puš 1991, 45 (Tumulus grund-plan), 48 f.

Na nekaterih sponah so obrobe sestavljene iz vzporednih linij iztolčenih pik in bunčic, ki so ob ožjih stranicah številnejše kot ob daljših stranicah, osrednji prostor mestoma zapolnjujejo figure ali pa je sredina prazna (*sl.* 65: 3, 5). Take obrobe so značilnost estenskih spon v stopnji Este IID1 in D2 po Peroniju (= III-srednje in pozno po Freyu), kjer so običajno kombinirane z vodoravnimi nizi krilatih živali.⁷³³ Čeprav gre za različne delavniške kroge, bi vseeno lahko v teh okrasnih obrobah videli isti koncept.

Posebno prvino na pravokotnih sponah predstavljajo cevčice iz bronaste pločevine z vrezanim motivom IIIIXIII, ki so pritrjene z zakovicami vzdolž krajših stranic (*sl.* 66: 2). Na Magdalenski gori jo zasledimo na pasni sponi iz groba 13/5 na Prelogah, ki je datiran v certoško stopnjo.⁷³⁴ Na Dolenjskem jo srečamo še med najdbami z Velikega Vinjega vrha (Šmarjete),⁷³⁵ iz Stične⁷³⁶ in Mokronoga.⁷³⁷ Enaka okrasna prvina se pojavlja na estenskih sponah iz časa Este IID1 in D2 (= Este III-srednje in pozno).⁷³⁸ Motiv vrezanih znakov IIIIXII nastopa na raznih predmetih iz starejšega in mlajšega halštatskega obdobja,⁷³⁹ med drugim tudi na negovsko čeladi iz Ženjaka italsko-slovenskega tip po Eggu.⁷⁴⁰

V zvezi z načinom okraševanja pasnih spon velja omeniti še fragmente bronaste pločevine z vodoravnimi rebri, ki so bili inventarizirani skupaj z negovsko čelado v sklopu nezanesljive grobne celote 2/1–2 s Prelog na Magdalenski gori (*sl.* 66: 21). Paralele za ta tip spon najdemo v moških grobovih v Novem mestu ter v Stični, ki pa nista najbolj kronološko zgovorna.⁷⁴¹

Velik del bronastih pravokotnih pasnih spon iz Dolenjske pa je neornamentiranih,⁷⁴² ki so pogoste

⁷³³ *Casa di Ricovero*, gr. 2(1961), *Casa Muletti Prosdoci*, gr. 260, *Villa Benvenuti*, gr. 81, 93, 103, 105, 106, 110, 114, 115; Chieco Bianchi/Calzavara Capuis 1985, T. 211: 2, 250: 5; Calzavara Capuis/Chieco Bianchi 2006, T. 60: 3, 83: 6, 103: 30, 105: 3, 108: 8, 112: 7, 123: 4,5, 128: 35; *Padova-Via Tiepolo*, gr.159; Capuis/Ruta Serafini 2002, 35 s, Fig. 2–4.

⁷³⁴ Tecco Hvala/Dular/Kocuvan 2004, T. 67A: 1.

⁷³⁵ Stare V. 1973a, T. 15: 3, 5.

⁷³⁶ Gabrovec et al. 2006, T. 116: 1; 163: 40.

⁷³⁷ Neobjavljeno, NMS inv. št. P 1543.

⁷³⁸ *Villa Benvenuti*, gr. 81, 86, 93,105; Calzavara Capuis/Chieco Bianchi 2006, T. 60: 3, 72: 16, 83: 6, 105: 3.

⁷³⁹ Egg 1996, 53 ss, Abb. 34. Na Magdalenski gori ga zasledimo npr. na žezlih, ražnjih, suličnih osteh, pasnih sponah iz 5. st. pr. n. št.: Tecco Hvala/Dular/Kocuvan 2004, T. 7: 5, 15: 8, 67: 1.

⁷⁴⁰ Egg 1986, Kat. Nr. 297, Abb. 175.

⁷⁴¹ *Novo mesto-Kapiteljska njiva*, gr. 1/32; Knez 1993, T. 28: 7; *Stična*, gr. 5/9; Gabrovec et al. 2006, T. 114: 1.

⁷⁴² *Brezje*: Kromer 1959a, T. 8: 1, 11: 1, 41: 3, 43: 1; *Dobrnjič*: Stare V. 1973b, T. 5: 4,18, 8: 12, 11: 1,5; *Parzinger* 1988–1989, T. 8: 10,11, 21: 1, 45: 1; *Dolenjske Toplice*: Teržan 1976, T. 25: 9, 51: 13, 59: 8, 61: 5; *Libna*: Guštin 1976, T. 47: 5,8; *Mokronog*: Dular J. 2003, T. 9: 2; *Podzemelj*: Barth 1969, T. 18: 1; *Dular* J. 1978, T. 16: 7, 17: 1; *Novo mesto*: Guštin/Teržan 1975, T. 4: 3; *Knez* 1986, T. 52: 1; *Rožno*: Dular J. 2003,

form part of numerous studies on that topic.⁷²² The scenes are framed by decorative borders that are either embossed, incised or punched. A guilloche border appears on clasps with figural scenes from Magdalenska gora (*fig.* 65: 4), Vače, Molnik, Stična and Brezje; while a guilloche border without a central motif (*fig.* 66: 5) can be seen on several pieces from Magdalenska gora,⁷²³ Vače⁷²⁴ and Most na Soči.⁷²⁵ The guilloche is characteristic of the Orientalising style and can be found on Etruscan architectural elements⁷²⁶ and stone stelae,⁷²⁷ on objects of ivory⁷²⁸ as well as gold and silver objects dating to the seventh and sixth centuries BC.⁷²⁹ It further appears on the situla from Histrian Nesactium,⁷³⁰ on belt clasps from the graves at Este, dating to Este IID2 after Peroni (= III Late after Frey),⁷³¹ and Most na Soči in the Sv. Lucija Ib phase (= Certosa phase in Dolenjska).⁷³²

The borders on some clasps are composed of parallel lines of embossed dots, more numerous along the shorter sides, while the central space is either filled with figural scenes or left empty (*fig.* 65: 3, 5). Such borders are characteristic of the Este clasps in phases Este IID1 and D2 after Peroni (= Este III Middle and Late after Frey), where they are usually combined with friezes of winged animals.⁷³³ These borders were produced in different workshop circles, but the concept behind them was common.

⁷²² *Umetnost alpskih Ilirov in Venetov* 1962; Lucke/Frey 1962; Frey 1969; Bonfante 1981; Teržan 1997; *ead.* 1998; *ead.* 2001a; *ead.* 2004b; Turk 2005 with references; Gleirscher 2009 and others.

⁷²³ Hencken 1978, Fig. 363a; Tecco Hvala/Dular/Kocuvan 2004, T. 92B: 1.

⁷²⁴ Stare F. 1952, T. 1: 5; *id.* 1955a: T. 44: 2.

⁷²⁵ Teržan/Lo Schiavo/Trampuž-Orel 1984, T. 142A: 4.

⁷²⁶ For example on slabs, on the so-called *Lastre Boccanera* from *Cerveteri*, on a tomb in *Tarquinia*: Bianchi Bandinelli/Guiliano 1973 (2000), Figs. 181, 207; on the slabs from the palace at *Poggio Civitate (Murlo)*: Bonfante 1981, Figs. 31–34 etc.

⁷²⁷ *Vulci*: Frey 1969, 64, Texttaf. D: 3.

⁷²⁸ For example from *Tomba Barberini (Praeneste-Palustrina)* or *Montefortini (Comeana)*: Torelli (ed.) 2000, 473 f, Cat. No. 119 with references.

⁷²⁹ For example on gold pectorals and bracelets with sphinx decoration and also on a bronze shield from *Tarquinia*: Hencken 1968a, Figs. 385B, 389–391; on bronze amfora from Orvieto or on a mirror from *Praeneste (Palustrine)*: Bonfante 1981, Figs. 55, 74 with references; on the *Providence* bronze situla: Lucke/Frey 1962, Beil. 1.

⁷³⁰ Mihovilić 2001, 100 f, Fig. 94, T. 15: 9.

⁷³¹ *Casa di Ricovero*, Gr. 219, *Villa Benvenuti*, Gr. 94; Chieco Bianchi/Calzavara Capuis 1985, T. 86: 14, 87: 22, 149b.

⁷³² Teržan/Lo Schiavo/Trampuž-Orel 1984, T. 142A.

⁷³³ *Casa di Ricovero*, Gr. 2(1961), *Casa Muletti Prosdoci*, Gr. 260, *Villa Benvenuti*, Gr. 81, 93, 103, 105, 106, 110, 114, 115; Chieco Bianchi/Calzavara Capuis 1985, T. 211: 2, 250: 5; Calzavara Capuis/Chieco Bianchi 2006, T. 60: 3, 83: 6, 103: 30, 105: 3, 108: 8, 112: 7, 123: 4,5, 128: 35; *Padova-Via Tiepolo*, Gr.159; Capuis/Ruta Serafini 2002, 35 f, Figs. 2–4.

predvsem v najmlajšem halštatskem obdobju (Ha D2–3), kar izpričujejo kombinacije s samostrelnimi fibulami z naprej gledajočo živalsko glavico,⁷⁴³ s certoškimi fibulami vrste XIII,⁷⁴⁴ plavutasto sekiro⁷⁴⁵ ipd.

Na osnovi tega pregleda je moč zaključiti, da ornamentalne tehnike in motivika niso kronološko pogojene, temveč odražajo stilni eklekticism dolenskih železnodobnih ustvarjalcev, ki so na eni strani v okraševanju posegali po žarnogrobiščni motiviki (koncentrični krožci, race in geometrijski motivi), po drugi strani pa prevzemali stilne prvine iz Italije (pletenica, figuralika).

4.4.3 KAVLJASTE IN PREDRTE PASNE SPONE

Kljub razlikam v materialu družijo pasne spone, prikazane na *sl.* 69, nekatere skupne značilnosti. Prvo skupino predstavljajo spone pravokotne oblike s sredinsko prečko, ki je posebej izdelana in se zaključuje v kavelj. Odlično ohranjen bronast izdelek te vrste ima na prečki pritrjene široke kolobarjaste obeske (*sl.* 69: 1), medtem ko sta železna primerka v zelo slabem stanju in lahko njuno obliko zgolj slutimo (*sl.* 69: 2, 3). Drugo vrsto spon predstavljajo primerki v predrti tehniki, ki so precej manjši in bolj razgibanih oblik. V eni izmed njih lahko prepoznamo shematizirano obliko ptice v letu (*sl.* 69: 4), oblika druge pa je zaradi fragmentiranosti slabše prepoznavna (*sl.* 69: 5). Preostali primerki posnemajo zgodnjelatenške prototipe (*sl.* 69: 6–15).

KAVLJASTE PASNE SPONE S SREDINSKO PREČKO

Bronasti primerki take spone (*sl.* 69: 1) je bil najden v gomili 5 na Prelogah, menda skupaj z dvema majhnima železnima suličnima ostema in ostanki bronastega kotlička.⁷⁴⁶ En železen fragmentiran primerki (*sl.* 69: 3) je objavljen med prdatki groba V/33 z Laščika, ki se ne ujemajo povsem z Goldbergovimi zabeležkami.⁷⁴⁷ Tako pasno spono bi lahko prepoznali tudi v železnem fragmentu (*sl.* 69: 2), ki ga hrani Narodni muzej v Ljubljani, vendar brez znane grobne celote.⁷⁴⁸

T. 57: 10; *Stična*: Wells 1981, Fig. 52, 64a-c; Gabrovec et al. 2006, T. 107: 1; *Vače*: Stare 1955a, T. 43: 1-3 in neobjavljeni primerki, NHMW inv. št. 6511, 6745, 8171, 8503; *Veliki Vinji vrh* (*Šmarjeta*): Dular A. 1991, T. 75: 14; *Volčje Njive*: Gabrovec 1956, T. 18: 2, 22: 6; *Vinkov Vrh*: Stare V. 1964–1965, T. 16: 1,4; *Zagorje*: Gabrovec 1966b, T. 9: 1,2.

⁷⁴³ *Brezje*, gr. 13/49: Kromer 1959a, T. 43: 1-11.

⁷⁴⁴ *Dolenjske Toplice*, gr. 7/14: Teržan 1976, T. 51: 1-13; *Novo mesto-Malenškova gomila*, gr. 3: Guštin/Teržan 1975, T. 4.

⁷⁴⁵ *Dolenjske Toplice*, gr. 10/9: Teržan 1976, T. 59: 1-9.

⁷⁴⁶ Tecco Hvala/Dular/Kocuvan 2004, 51, T. 158: 2.

⁷⁴⁷ Hencken 1978, 38, Fig. 153e.

⁷⁴⁸ Tecco Hvala/Dular/Kocuvan 2004, T. 158: 5.

A particular element on the rectangular clasps is small tubes of bronze sheet with an incised IIIIXIII motif, which are attached with rivets along the shorter sides (*fig.* 66: 2). Such an element is present on the clasp from Grave 13/5 at Preloge dated to the Certosa phase.⁷³⁴ Elsewhere in Dolenjska they were found at Veliki Vinji vrh (*Šmarjeta*),⁷³⁵ *Stična*⁷³⁶ and *Mokronog*.⁷³⁷ The same element appears on clasps from Este and dates to Este IIID1 and D2 (= Este III Middle and Late).⁷³⁸ The motif of incised IIIIXII appears on various objects from the Early and Late Hallstatt period,⁷³⁹ including the Negova helmet of Italo-Slovenian type after Egg from Ženjak.⁷⁴⁰

In connection with the manner of decorating belt clasps I should also mention the bronze sheet fragments with horizontal ribs, which are inventoried together with a Negova helmet as part of the unreliable Grave Group 2/1–2 from Preloge (*fig.* 66: 21). Parallels for this clasp type can be found in male graves from Novo mesto and *Stična*, but these are not chronologically telling.⁷⁴¹

The majority of the bronze rectangular belt clasps from Dolenjska is undecorated.⁷⁴² They are most frequent in the latest Hallstatt period (Ha D2–3), as evidenced by combinations with crossbow fibulae with a forward-facing animal head,⁷⁴³ Type XIII Certosa fibulae,⁷⁴⁴ a one-sided winged axe⁷⁴⁵ and others.

The overview above showed that neither the decorative techniques nor the motifs are chronologically determined, but are rather an expression of a stylistic

⁷³⁴ Tecco Hvala/Dular/Kocuvan 2004, T. 67A: 1.

⁷³⁵ Stare V. 1973a, T. 15: 3, 5.

⁷³⁶ Gabrovec et al. 2006, T. 116: 1; 163: 40.

⁷³⁷ Unpublished, NMS Inv. No. P 1543.

⁷³⁸ *Villa Benvenuti*, Gr. 81, 86, 93,105: Calzavara Capuis/Chiecho Bianchi 2006, T. 60: 3, 72: 16, 83: 6, 105: 3.

⁷³⁹ Egg 1996, 53 ff, Abb. 34. At Magdalenska gora, it is evidenced on maces, spits, spearheads, belt clasps from the fifth century BC: Tecco Hvala/Dular/Kocuvan 2004, T. 7: 5, 15: 8, 67: 1.

⁷⁴⁰ Egg 1986, Kat. Nr. 297, Abb. 175.

⁷⁴¹ *Novo mesto-Kapiteljska njiva*, Gr. 1/32: Knez 1993, T. 28: 7; *Stična*, Gr. 5/9: Gabrovec et al. 2006, T. 114: 1.

⁷⁴² *Brezje*: Kromer 1959a, T. 8: 1, 11: 1, 41: 3, 43: 1; *Dobrnich*: Stare V. 1973b, T. 5: 4,18, 8: 12, 11: 1,5; Parzinger 1988–1989, T. 8: 10,11, 21: 1, 45: 1; *Dolenjske Toplice*: Teržan 1976, T. 25: 9, 51: 13, 59: 8, 61: 5; *Libna*: Guštin 1976, T. 47: 5,8; *Mokronog*: Dular J. 2003, T. 9: 2; *Podzemelj*: Barth 1969, T. 18: 1; Dular J. 1978, T. 16: 7, 17: 1; *Novo mesto*: Guštin/Teržan 1975, T. 4: 3; Knez 1986, T. 52: 1; *Rožno*: Dular J. 2003, T. 57: 10; *Stična*: Wells 1981, Figs. 52, 64a-c; Gabrovec et al. 2006, T. 107: 1; *Vače*: Stare 1955a, T. 43: 1-3 and unpublished examples, NHMW Inv. Nos. 6511, 6745, 8171, 8503; *Veliki Vinji vrh* (*Šmarjeta*): Dular A. 1991, T. 75: 14; *Volčje Njive*: Gabrovec 1956, T. 18: 2, 22: 6; *Vinkov Vrh*: Stare V. 1964–1965, T. 16: 1,4; *Zagorje*: Gabrovec 1966b, T. 9: 1,2.

⁷⁴³ *Brezje*, Gr. 13/49: Kromer 1959a, T. 43: 1-11.

⁷⁴⁴ *Dolenjske Toplice*, Gr. 7/14: Teržan 1976, T. 51: 1-13; *Novo mesto-Malenšek tumulus*, Gr. 3: Guštin/Teržan 1975, T. 4.

⁷⁴⁵ *Dolenjske Toplice*, Gr. 10/9: Teržan 1976, T. 59: 1-9.

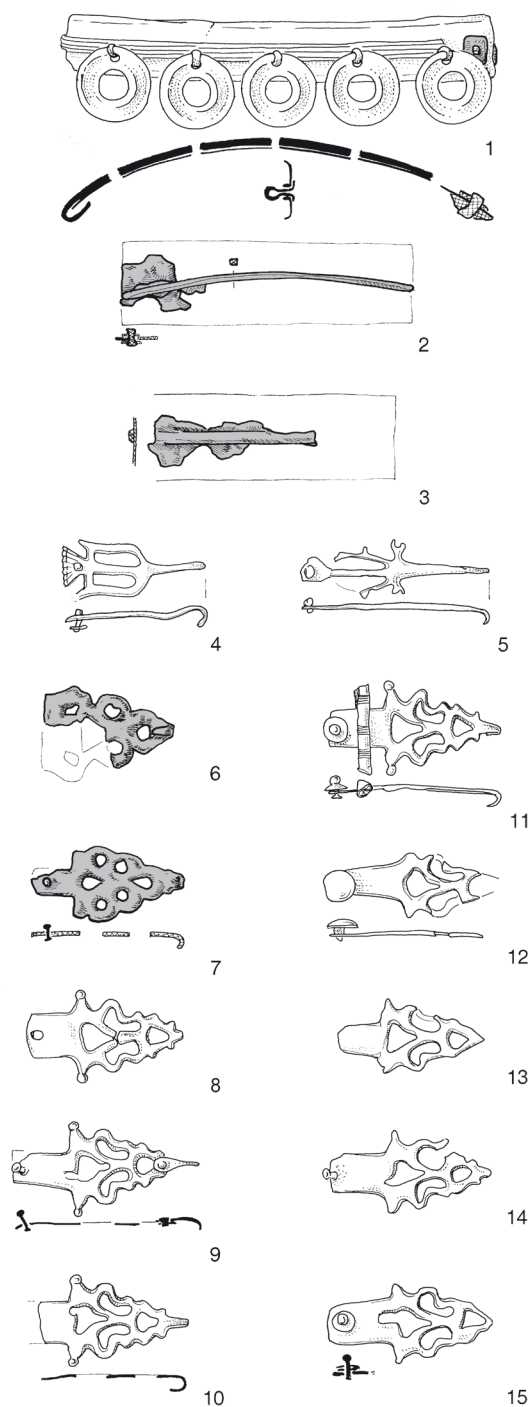

Sl. 69: Kavljaste in predrte pasne spone z Magdalenske gore. 2, 3, 6, 7 = železo; ostalo = bron. M. = 1:4.

Fig. 69: Hook belt clasps with a central bar and openwork belt clasps from Magdalenska gora. 2, 3, 6, 7 = iron; other = bronze. Scale = 1:4.

1, 2, 9, 10 – najdbe brez znanih grobnih celot v NMS / finds without preserved contexts kept in the NMS; 3 – Laščik, gr. V/33; 4 – Laščik, gr. V/6–7a–7; 5 – Preloge, gr. X/14; 6, 11 – Preloge, gr. X/32–33; 7 – Preloge, gr. 13/63; 8 – Laščik, gr. V/5; 12 – Preloge, gr. VI/39; 13 – Preloge, gr. 13/1; 14 – Preloge, gr. 2/71; 15 – Laščik, gr. V/47.

eclecticism of the Iron Age craftsmen of Dolenjska, who drew from the Urnfield culture tradition (concentric circles, ducks and geometric designs), on the one hand, and borrowed stylistic elements from Italy (guilloche, figural scenes), on the other.

4.4.3 HOOK AND OPENWORK BELT CLASPS

In spite of the differences in material, the belt clasps on fig. 69 have several common features. The first type is constituted by rectangular clasps with a separately made central bar terminating in a hook. A perfectly preserved bronze clasp of this group has five rings attached to the bar (fig. 69: 1), while the iron clasps are poorly preserved and their form can only be supposed (fig. 69: 2, 3). The second type is constituted by openwork clasps, which are much smaller. One of them represents a bird in flight (fig. 69: 4), while the shape of the other cannot be determined due to poor preservation (fig. 69: 5). The other clasps are imitations of Early La Tène prototypes (fig. 69: 6–15).

HOOK BELT CLASP WITH A CENTRAL BAR

An example made of bronze (fig. 69: 1) was found in Tumulus 5 at Preloge, reportedly together with two small iron spearheads and remains of a bronze cauldron.⁷⁴⁶ One fragmented iron example (fig. 69: 3) is published among the goods from Grave V/33 at Laščik, though the published list does not correspond to Goldberg's notes.⁷⁴⁷ This type could also be identified in an iron fragment (fig. 69: 2) kept, without data on the grave group, in the National Museum in Ljubljana.⁷⁴⁸

Clasps of this type, either of bronze or iron, were found on several other sites in Dolenjska.⁷⁴⁹ Their time frame of the Late Certosa and Early Negova phases is indicated by the grave groups from Dolenjske Toplice and Novo mesto, where they were found together with a double-crested or a Negova helmet, Types XII or XIII Certosa fibulae, one-sided winged axes and a knife with a flat tang.⁷⁵⁰ Individual examples also came to light in

⁷⁴⁶ Tecco Hvala/Dular/Kocuvan 2004, 51, 141, T. 158: 2.

⁷⁴⁷ Hencken 1978, 38, Fig. 153e.

⁷⁴⁸ Tecco Hvala/Dular/Kocuvan 2004, T. 158: 5.

⁷⁴⁹ Dobrnič: Stare V. 1973b, T. 9: 9, 14: 15; *Dolenjske Toplice*: Teržan 1976, T. 49: 5, 71: 1; *Novo mesto*: Knez 1986, T. 8: 1, 13: 14, 26: 1, 35: 1, 43: 21; *Podzemelj*: Barth 1969, T. 19: 9; Dular J. 1978, T. 16: 8, 17: 4; *Vače*: unpublished, NHMW Inv. Nos. 6593, 8512, 40146, B 30; *Veliki Vinji vrh (Šmarjeta)*: Stare V. 1973a, T. 16: 3; *Vinkov vrh*: Stare V. 1964–1965, T. 3: 6.

⁷⁵⁰ *Dolenjske Toplice, Gr. 7/8, 11/26*: Teržan 1976, 388 f, T. 49, 71; *Novo mesto-Znančeve njive, Gr. 1/23, 2/2, 4/3*: Knez 1986, T. 6–8, 13, 30–37.

V bronasti ali železni izvedbi so znane še z nekaterih dolenskih najdiščih.⁷⁴⁹ Časovni okvir njihovega pojavljanja v mlajši certoški in zgodnji negovski stopnji nakazuje grobne celote iz Dolenskih Toplic in Novega mesta, kjer jih zasledimo v kombinacijah z dvogrebenasto ali negovsko čelado, s certoškimi fibulami vrst XII ali XIII, s sekirami z enostranskimi plavutmi in nožem s ploščatim nastavkom za ročaj.⁷⁵⁰ Posamični primerki so znani z območja zahodne Panonije in severozahodnega Balkana,⁷⁵¹ ki so tako pomemben pokazatelj stikov in menjave med različnimi skupnostmi. Pripisali bi jih lahko dolenskem snovanju v poslednjih fazah starejše železne dobe, čeprav podobno obliko pasnih spon zasledimo tudi v svetolucijskem krogu, vendar ne v železni izvedbi niti ne z okrasnimi obročki na sredinski prečki.⁷⁵²

PREDRTI PASNE SPONE

V predrti tehniki je bila izdelana bronasta pasna spona v obliki ptice (sl. 69: 4), najdena v že večkrat omenjenem grobu konjenika V/6–7a–7 z Laščika na Magdalenski gori.⁷⁵³ Slabše ohranjen primerek (sl. 69: 5) je pripadal oboroženemu moškemu v grobu X/14, ki je menda imel še dve certoški fibuli in konjski zob kot amulet.⁷⁵⁴

Podobno oblikovane spona so bile najdene v okolici Velikega Vinjega vrha oz. Šmarjete, vendar grobne celote niso znane.⁷⁵⁵ V Vintarjevcu je bila tovrstna železna spona najdena v bogatem ženskem grobu skupaj s certoško fibulo vrste XIII, fibulo s svinčeno oblogo v obliki živali, drobno ločno fibulo, prelepo pisano stekleno ogrlico z jagodami v obliki ovnovih glav in kavri polži, valjastimi uhani, votlima zapestnicama in nanožnicami. Enostavnejše oblike je bronast primerki iz Kostrevnice.⁷⁵⁶ Približno v ta čas spada tudi grob 21/1 iz Brusnic, ki je vseboval certoški fibuli vrste Ib, bronasto situlo in lončenino.⁷⁵⁷ Tudi te spona bi lahko uvrstili

⁷⁴⁹ Dobrnič: Stare V. 1973b, T. 9: 9, 14: 15; *Dolenske Toplice*: Teržan 1976, T. 49: 5, 71: 1; *Novo mesto*: Knez 1986, T. 8: 1, 13: 14, 26: 1, 35: 1, 43: 21; *Podzemelj*: Barth 1969, T. 19: 9 in Dular J. 1978, T. 16: 8, 17: 4; *Vače*: neobjavljeno, NHMW inv. št. 6593, 8512, 40146, B 30; *Veliki Vinji vrh (Šmarjeta)*: Stare V. 1973a, T. 16: 3; *Vinkov vrh*: Stare V. 1964–1965, T. 3: 6.

⁷⁵⁰ *Dolenske Toplice, gr. 7/8, 11/26*: Teržan 1976, 388 s, T. 49, 71; *Novo mesto-Znančeve njive, gr. 1/23, 2/2, 4/3*: Knez 1986, T. 6–8, 13, 30–37.

⁷⁵¹ Teržan 1976, 388 s, op. 225. *Donja Dolina-M. Petrović Jr., gr. 24*: Truhelka 1904, T. 45: 16; *Sanski most*: Čović 1987, 259, T. 28: 22; *Duvno-Crvenica*: id. 1961–1962, 35, sl. 9; *Livno-Vašarovine*: Marijan 1985–1986, 32, T. 1: 4; *Szentlőrinc*: Jerem 1968, Fig. 19/6: 2; 24/31: 3.

⁷⁵² Marchesetti 1993, T. 26: 3–6.

⁷⁵³ Hencken 1978, 30 s, Fig. 109a.

⁷⁵⁴ *Ibid.*, 67 s, Fig. 304i.

⁷⁵⁵ Stare F. 1953, T. 9: 1; Stare V. 1973a, T. 15: 8, 16: 1, 13.

⁷⁵⁶ Stare F. 1953, T. 2: 5, 8: 1.

⁷⁵⁷ Teržan 1974, 45, T. 18: 5.

western Pannonia and the north-western Balkans,⁷⁵¹ which point to the contacts and trading among the different communities. A similar shape of clasps is known also within the Sveta Lucija circle, though not made of iron and without the rings on the central bar.⁷⁵²

OPENWORK BELT CLASP

One example in the shape of a bird (fig. 69: 4) was found in Grave V/6–7a–7 of a horseman, at Laščik, mentioned several times above.⁷⁵³ A less well preserved example (fig. 69: 5) was found in male Grave X/14, together with two Certosa fibulae and a horse tooth as an amulet.⁷⁵⁴

Similarly shaped clasps were recorded near Veliki Vinji vrh (Šmarjeta), though their grave groups are not known.⁷⁵⁵ At Vintarjevec, an iron clasp of this type was found in a rich female grave together with a Type XIII Certosa fibula, a fibula with a lead overlay in the shape of an animal, a small bow fibula, a beautiful multicoloured glass necklace with beads in the shape of ram's heads and with cowries, cylindrical earrings, two hollow bracelets and several armlets. Of a simpler shape is the bronze example from Kostrevnica.⁷⁵⁶ Roughly the same time frame could be attributed to Grave 21/1 from Brusnice, which contained two Ib Certosa fibulae, a bronze situla and pottery.⁷⁵⁷ The clasps of this type show a geographically limited appearance and could therefore also be seen as products of local craftsmen in the Certosa and Negova phases. Outside Dolenska, two examples were found in the Sveta Lucija circle, at Koritnica ob Bači – in Grave 13 in combination with a Type XIII Certosa fibula and in Grave 27 with a multicoloured bead and a band earring of the Sveta Lucija type, which indicates a female burial.⁷⁵⁸

Openwork belt clasps of the Early La Tène scheme from the territory of the Dolenska Hallstatt community were collected and analysed by Frey.⁷⁵⁹ His findings have thus far not been challenged; I will therefore present their contexts in the light of Pečnik's information and Goldberg's descriptions, the latter summarized by Hencken. The iron openwork clasp (fig. 69: 7) was found in Grave 13/63 at the hips of the deceased, who further

⁷⁵¹ Teržan 1976, 388 f, n. 225. *Donja Dolina-M. Petrović Jr., Gr. 24*: Truhelka 1904, T. 45: 16; *Sanski most*: Čović 1987, 259, T. 28: 22; *Duvno-Crvenica*: id. 1961–1962, 35, sl. 9; *Livno-Vašarovine*: Marijan 1985–1986, 32, T. 1: 4; *Szentlőrinc*: Jerem 1968, Figs. 19/6: 2; 24/31: 3.

⁷⁵² Marchesetti 1993, T. 26: 3–6.

⁷⁵³ Hencken 1978, 30 f, Fig. 109a.

⁷⁵⁴ *Ibid.*, 67 f, Fig. 304i.

⁷⁵⁵ Stare F. 1953, T. 9: 1; Stare V. 1973a, T. 15: 8, 16: 1, 13.

⁷⁵⁶ Stare F. 1953, T. 2: 5, 8: 1.

⁷⁵⁷ Teržan 1974, 45, T. 18: 5.

⁷⁵⁸ Kos 1973, 862, T. 4: 2, 7: 2.

⁷⁵⁹ Frey 1974a; id. 1987.

med izdelke domačih obrtnikov, saj so geografsko zelo omejene, časovno pa jih lahko opredelimo v certoško in negovsko stopnjo. Izven dolenskega teritorija sta znana dva primerka iz grobišča svetolucijskega kroga na Koritnici ob Bači, kjer jo zasledimo v grobu 13 v kombinaciji s certoško fibulo vrste XIII, v grobu 27 pa s pisano jagodo in trakastim uhanom svetolucijskega tipa, kar govori za ženski grob.⁷⁵⁸

Predrte pasne sponे zgodnjelatske sheme z ozemlja dolenske halštatske skupnosti je zbral in ovrednotil Frey.⁷⁵⁹ Slika, ki jo je podal za ta prostor, se do danes ni spremenila, zato bom na tem mestu osvetlila magdalenkogorske kontekste v luči Pečnikovih podatkov ter Goldbergovih opisov, ki jih povzema Hencken v objavi grobnih celot. Železna predrta pasna spona (sl. 69: 7) je bila najdena v grobu 13/63 na kolkih umrlega, ki je imel pri nogah tulasto sekuro, nož in sulično ost.⁷⁶⁰ Drug tak primerk (sl. 69: 6) je objavljen med pridatki dvojnega groba X/32–33, o katerem je Goldberg zapisal, da sta okostji ležali drugo poleg drugega, obdajal pa ju je venec kamnov, velikih kot pest ali glava. Bolje ohranjeno okostje v tem grobu je imelo menda fino spono (sl. 69: 11), šest večjih obročkov ter okove v obliki rozet, ki so bili najbrž pritrjeni na usnjen pas; razen tega še dve certoški fibuli, majhno sekuro, nož in koščke lesa, okovane z bronastimi žeblički, medtem ko je imelo slabše ohranjeno okostje le majhno železno sekuro. Železne sponе ne omenja, prav tako ne cele vrste drugih predmetov, ki so objavljeni v tem sklopu.⁷⁶¹ Angel je okostje, ki je bilo v dobrem stanju, opredelil za moškega zrelih let z dinarsko-mediteranskimi potezami, medtem ko pri drugem ni mogel določiti spola in starosti, ugotovil pa je medvretenčno hernijo ter deformacijo vretenc in tibije.⁷⁶²

Nič bolj jasne niso grobne celote, v katerih so objavljeni drugi bronasti primerki pasnih spon zgodnjelatske sheme. V grobu V/47 z Laščika Goldberg navaja eno spono, objavljeni pa sta ozka pravokotna spona in še ena predrta (sl. 69: 15), ki jo hrani Narodni muzej v Ljubljani.⁷⁶³ O grobu V/5 (sl. 69: 8) je zapisal, da je bil poškodovan in predmeti razmetani;⁷⁶⁴ v zvezi z grobnim inventarjem VI/39 (sl. 69: 12) pa je pripomnil, da sta bili sekiri odkriti približno pol metra nad grobom.⁷⁶⁵ Iz njegovih zabeležk je razvidno, da so ti grobovi očitno ležali dokaj plitvo in marsikje na samem robu gomile. Podobno bi lahko skleпали tudi za grobove, ki so inventarizirani v Naravoslovnem muzeju na Dunaju. Szombathy je zapisal, da je grob 13/1 ležal 15 cm pod rušo, nič pa ne govori o predrti pasni sponi (sl. 69: 13) niti o sulici, ki

had a socketed axe, a knife and a spearhead.⁷⁶⁰ The other example (fig. 69: 6) was published among the goods of double Grave X/32–33, of which Goldberg reported the skeletons lying in parallel position surrounded by a ring of stones the size of a fist or a head. The better preserved skeleton of the two reportedly had a fine clasp (fig. 69: 11), six large rings, rosette-shaped fittings, probably attached to a leather belt, two Certosa fibulae, a small axe, a knife and pieces of wood fitted with bronze studs. The other skeleton only had a small iron axe. He made no mention of the iron clasp, but was silent also on numerous other finds published as part of the grave group.⁷⁶¹ Angel determined the better preserved skeleton as that of a mature male with Dinaric-Mediterranean traits. For the other skeleton neither the sex nor the age could be determined, though he did observe intervertebral hernia as well as deformations of the vertebrae and the tibia.⁷⁶²

The grave groups with other bronze belt clasps of the Early La Tène scheme are no clearer. For Grave V/47 from Laščik, for example, Goldberg states one clasp, while the publication includes a narrow rectangular and an openwork clasp (fig. 69: 15), the latter held in the National Museum in Ljubljana.⁷⁶³ Of Grave V/5 (fig. 69: 8), Goldberg wrote that it was damaged and the goods scattered;⁷⁶⁴ while in connection with the goods in Grave VI/39 (fig. 69: 12) he noted that two axes had been found roughly half a metre above the grave.⁷⁶⁵ His notes thus reveal that these graves were dug rather shallow into the mound and often at the edges. A similar conclusion could be reached for the graves, the goods of which are inventoried in the museum in Vienna. In connection with those, Szombathy wrote that Grave 13/1 was found 15 cm under the sod, but made no mention of the openwork belt clasp (fig. 69: 13) or of the spear, listed among the grave goods.⁷⁶⁶ An openwork clasp is, on the other hand, mentioned with Graves 2/12 and 2/71 from Preloge, both of which were damaged by subsequent cuts in the Late La Tène period. Grave 2/71 contained, apart from the clasp (fig. 69: 14), a shaft-hole axe, a small spearhead and two Late La Tène fibulae, while Pečnik further mentions nine glass pendants with bronze loops threaded onto a string, as well as small glass beads.⁷⁶⁷ As for Grave 2/12, Pečnik marked it as La Tène and listed a bent iron sword in its scabbard, a chain, umbo, whetstone, belt rings and a "Gürtel Schloß neue Gattung aus Bronze" as its goods, while the inventory book of the museum in Vienna records an openwork belt clasp,

⁷⁵⁸ Kos 1973, 862, T. 4: 2, 7: 2.

⁷⁵⁹ Frey 1974a; id. 1987.

⁷⁶⁰ Tecco Hvala/Dular/Kocuvan 2004, 62, T. 88B: 1.

⁷⁶¹ Hencken 1978, 71, Fig. 322o, 323g.

⁷⁶² Angel 1968, 78, Fig. 3, 16. Glej tu poglavje 1.1.3, sl. 6.

⁷⁶³ Hencken 1978, 41, Fig. 167g.

⁷⁶⁴ *Ibid.*, 29 s, Fig. 106c.

⁷⁶⁵ *Ibid.*, 49, Fig. 213c.

⁷⁶⁰ Tecco Hvala/Dular/Kocuvan 2004, 62, 150, T. 88B: 1.

⁷⁶¹ Hencken 1978, 71, Figs. 322o, 323g.

⁷⁶² Angel 1968, 78, Figs. 3, 16. See Chapter 1.1.3, fig. 6.

⁷⁶³ Hencken 1978, 41, Fig. 167g.

⁷⁶⁴ *Ibid.*, 29 f, Fig. 106c.

⁷⁶⁵ *Ibid.*, 49, Fig. 213c.

⁷⁶⁶ Tecco Hvala/Dular/Kocuvan 2004, 53, 143.

⁷⁶⁷ *Ibid.*, 47, T. 59C: 3.

sta zavedeni kot inventar tega groba.⁷⁶⁶ Je pa taka spona omenjena v grobovih 2/12 in 2/71 s Prelog, ki sta bila poškodovana z naknadnimi vkopi v poznolatenskem času. V grobnem sestavu 2/71 nastopata poleg spona (sl. 69: 14), uhate sekire in majhne sulične osti tudi dve poznolatenski fibuli, razen tega Pečnik našteva še devet steklenih obeskov z bronastimi zankami, nanizanih na vrstico, ter majhne steklene jagodice.⁷⁶⁷ Grob 2/12 je označil za latenski, vseboval je zvit železni meč v nožnici, verigo, ščitno grbo, sulične osti, brusni kamen ter pasne obročke in "Gürtel Schloß neue Gattung aus Bronze". V inventarni knjigi dunajskega muzeja je vpisana predrta pasna spona, ki je danes izgubljena.⁷⁶⁸ V Narodnem muzeju v Ljubljani sta dve predrta pasni sponi brez znanih grobnih celot (sl. 69: 9, 10), ki domnevno izvirata iz Pečnikovih začetnih kopanj gomile 2 na Prelogah.⁷⁶⁹ Med bronaste izdelke te vrste spada še primerek v privatni lasti, ki ga je nedavno objavil Švajncer, brez natančnejših podatkov o odkritju in kontekstu te najdbe.⁷⁷⁰

Čeprav grobne celote z Magdalenske gore, v katerih so inventarizirane predrte pasne spona zgodnjelatenske sheme, niso povsem zanesljive, pa njihovo mesto v negovski stopnji ni sporno.⁷⁷¹ To potrjuje grob 13/4 iz Dolenjskih Toplic s certoško fibulo vrste XII, dvema suličnima ostema, sekiro z enostranskimi plavutmi in nožem s ploščatim nastavkom za držaj.⁷⁷² Tam je bila najdena še v grobu 13/6 skupaj z železno fibulo; gre za precej okorno izdelano železno spono, ki v zasnovi predstavlja domačo rombično obliko, le da je na več mestih preluknjana.⁷⁷³ Nasploh je dolenjske primerke moč označiti za lokalne posnetke zgodnjelatenskih vzorov, ki so v ta prostor prodrli domnevno prek severne Italije, kjer jih povezujejo s prvimi vpadi keltskih plemen.⁷⁷⁴

Pasne spona se v jugovzhodnih Alpah pojavljajo vse od mlajše stopnje kulture žarnih grobišč naprej. V fazah Ljubljana Ib in IIa so bile v uporabi bronaste dvojnokrižne oblike.⁷⁷⁵ Na Dolenjskem so jih na začetku železne dobe, tj. v stopnji Podzemelj, zamenjale pasne garniture s

which is now lost.⁷⁶⁸ The National Museum in Ljubljana further keeps two openwork clasps without known grave goods (fig. 69: 9, 10), which were supposedly brought to light by Pečnik during his early excavations of Tumulus 2 at Prelog.⁷⁶⁹ Bronze objects of the type further include a privately-owned example recently published by Švajncer, without detailed information as to its find circumstances and context.⁷⁷⁰

As seen from the above, the grave groups in which openwork belt clasps of the Early La Tène scheme from Magdalenska gora are inventoried are not reliable. Nevertheless, their date into the Negova phase is undisputed.⁷⁷¹ This is confirmed by Grave 13/4 from Dolenjske Toplice the group of which included a Type XII Certosa fibula, two spearheads, one-sided winged axe and a knife with a flat tang.⁷⁷² At the same site, another openwork clasp was found in Grave 13/6 together with an iron fibula. The latter clasp was rather roughly made, basically rhombic in shape but perforated in several places.⁷⁷³ In general, the openwork clasps from Dolenjska may be viewed as local imitations of the Early La Tène clasps, which arrived there via northern Italy, where such clasps are tied to the first incursions of the Celtic tribes.⁷⁷⁴

Belt clasps appear in the south-eastern Alps from the late phase of the Urnfield culture onwards. In Phases Ljubljana Ib and II, bronze double-cruciform examples were in use.⁷⁷⁵ At the beginning of the Iron Age, in the Podzemelj phase, these were replaced in Dolenjska by belt sets with rectangular plates made of sheet bronze and usually decorated with embossed dots. Guštin and Preložnik named them Type Malence – after the examples found at Velike Malence in a grave with a bowl-shaped helmet – and also proposed a reconstruction of such a belt.⁷⁷⁶ The bronze rectangular belt clasps, with rows of rivets along the shorter sides and a separately made hook, appeared in the Stična phase, as is evidenced by the grave with cuirass from Stična as well as Grave IV/3

⁷⁶⁸ Frey 1974a, 130; Tecco Hvala/Dular/Kocuvan 2004, 34, 128.

⁷⁶⁹ Tecco Hvala/Dular/Kocuvan 2004, T. 158: 6,7.

⁷⁷⁰ Švajncer 2012, 7 ff.

⁷⁷¹ Frey 1974a, 136 f, n. 13.

⁷⁷² Frey 1974a, 135, Abb. 4; Teržan 1976, 388 f, 78: 5.

⁷⁷³ Teržan 1976, T. 74: 6.

⁷⁷⁴ Frey 1974a, 140 f, Abb. 8; Teržan 1976, 389, Karte 57; Frey 1987, Fig. 1; Calzavara Capuis/Ruta Serafini 1987, Figs. 2, 4, 13: 8, 21: 18,20, 23: 1, Parzinger 1988, T. 150: 1.1.

⁷⁷⁵ Ložar 1934, 34 ff; Stare F. 1960, 83 ff, Abb. 2, 4, 6: 3, 7, 8: 1-3; Gabrovec 1973, 342, Tabelle 1, Abb. 3, T. 6: 1, 9: 1-3; Kilian-Dirlmeier 1975, 85 ff, T. 28: 346-357, 29: 358-364; Spindler 1978, 95 ff, Abb. 2; Božič 1978, 735 ff; Gabrovec 1983, Figs. 7: 17, 8: 6; Teržan 1987, 7 f, n. 8, Fig. 1: 9; ead. 1990a, Map 3.

⁷⁷⁶ Guštin/Preložnik 2005, 138 ff, Figs. 22–25.

⁷⁶⁶ Tecco Hvala/Dular/Kocuvan 2004, 53.

⁷⁶⁷ Ibid., 47, T. 59C: 3.

⁷⁶⁸ Frey 1974a, 130; Tecco Hvala/Dular/Kocuvan 2004, 34 s.

⁷⁶⁹ Tecco Hvala/Dular/Kocuvan 2004, T. 158: 6,7.

⁷⁷⁰ Švajncer 2012, 7 ss.

⁷⁷¹ Frey 1974a, 136 s, op. 13.

⁷⁷² Frey 1974a, 135, Abb. 4; Teržan 1976, 388 s, 78: 5.

⁷⁷³ Teržan 1976, T. 74: 6.

⁷⁷⁴ Frey 1974a, 140 s, Abb. 8; Teržan 1976, 389, karta 57; Frey 1987, Fig. 1; Calzavara Capuis/Ruta Serafini 1987, Fig. 2, 4, 13: 8, 21: 18,20, 23: 1, Parzinger 1988, T. 150: 1.1.

⁷⁷⁵ Ložar 1934, 34 ss; Stare F. 1960, 83 ss, sl. 2, 4, 6: 3, 7, 8: 1-3; Gabrovec 1973, 342, Tabela 1, sl. 3, T. 6: 1, 9: 1-3; Kilian-Dirlmeier 1975, 85 ss, T. 28: 346-357, 29: 358-364; Spindler 1978, 95 ss, Abb. 2; Božič 1978, 735 ss; Gabrovec 1983, sl. 7: 17, 8: 6; Teržan 1987, 7 s, op. 8, Fig. 1: 9; ead. 1990a, karta 3.

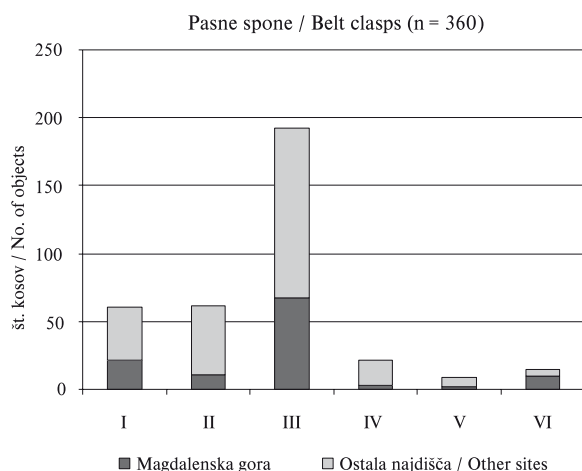

Stopnje / Phases	Vrste pasnih spon / Types of belt clasps
Stična	1
	2
Kačaste fibule Serpentine fibulae	1
	2
Certoške fibule Certosa fibulae	1
	2
Negovske čelade Negova helmets	1
	2

Sl. 70: Deleži posameznih tipov pasnih spon v dolenjski skupnosti in njihov časovni razpon.

Fig. 70: Shares of individuals belt clasp types in the Dolenjska community and their chronological span.

I – železne rombične / iron rhombic, **II** – železne pravokotne / iron rectangular, **III** – bronaste pravokotne / bronze rectangular, **IV** – kavljaste s sredinsko prečko / hook with central bar, **V** – predrte v obliki stilizirane ptice v letu / openwork in the shape of flying bird, **VI** – predrte zgodnjelatskega tipa / Early La Tène openwork type.

pravokotnimi okovi, ki so izdelani iz bronaste pločevine in običajno okrašeni z iztločenimi buncicami in pikami. Guštin in Preložnik sta jih poimenovala tip Malence – po primerkih iz groba s skledasto čelado s tega najdišča – in podala možno rekonstrukcijo takega pasu.⁷⁷⁶ Bronaste pravokotne pasne sponje, ki imajo vrsto zakovic ob ožjih stranicah za pritrnitev na podlogo ter posebej izdelan kavelj, se pojavijo v stopnji Stična, kot kažeta grob z oklepom iz Stične ter grob IV/3 z Magdalenske gore s sestavljeno čelado. V mladohalštatskem času so predstavljale vodilno obliko ter prepoznavni znak dolenjske moške noše. V certoški stopnji so se nekateri izbranci ponašali s figuralno okrašenimi primerki. Sočasno so bile v rabi tudi železne sponje pravokotne ali rombične oblike (sl. 70: I); slednje so bolj običajne v skromnih opravah, nastopajo pa tudi v ženski noši in nakazujejo povezave z eponimnim najdiščem halštatske kulture.

Ob koncu certoške stopnje so vzniknile nekatere nove oblike, kot so kavljaste sponje s sredinsko prečko (sl. 70: IV), ki so jih nosili moški. Razen teh so izdelovali še majhne sponje v predrti tehniki raznih stiliziranih oblik, ki jih srečamo tudi v ženskih opravah (sl. 70: V). V negovski stopnji pa so v moški noši sprejeli zgodnjelatske modele v poenostavljeni obliki (sl. 70: VI).

Magdalenska gora spada po številu pasnih spon v sam vrh med halštatskimi najdišči jugovzhodnoalpskega območja. Vendar od tod niso znani niti žarnogrobniški tip niti najzgodnejši halštatski primerki. Najstarejši kos na tem najdišču domnevno predstavlja bronasta pravokotna spona z zakovicami, ki naj bi bila najdena v grobu IV/3 s Prelog s sestavljeno čelado. V to vrsto sodi kar polovica vseh pasnih spon, ki so zabeležene

with composite helmet from Magdalenska gora. In the Late Hallstatt period, bronze rectangular belt clasps represented the leading form as well as a distinguishing mark of the male costume of Dolenjska. The high-ranking men in the Certosa phase even boasted figurally decorated examples. Used contemporarily were also iron clasps of rectangular or rhombic shapes (fig. 70: I); the latter being more frequent in the poorer costumes and also forming parts of female costumes. They also indicate connections with the eponym site of the Hallstatt culture.

New forms appeared at the end of the Certosa phase, namely hook clasps with a central bar (fig. 70: IV), which were worn by men. Also produced were small openwork clasps of various stylized shapes, which formed parts of the female costume as well (fig. 70: V). Finally, in the Negova phase, Early La Tène models were accepted in simplified forms and worn only by men (fig. 70: VI).

Magdalenska gora ranks among the Hallstatt sites in the south-eastern Alpine area with the highest number of recovered clasps. However, neither the Urnfield culture types nor the earliest Hallstatt forms have been found here; the earliest clasp is presumably the bronze rectangular clasp with rivets from Grave IV/3 at Preloge with a composite helmet. Belonging to this type is almost half the clasps from the site, which represent a third of all clasps of this type on the territory of the Dolenjska Hallstatt community (fig. 70: III). The iron rhombic belt clasps of Magdalenska gora represent a third of all such clasps (fig. 70: I), the iron rectangular example just over a sixth (fig. 70: II), while the openwork clasps of Early La Tène scheme as much as two thirds (fig. 70: VI). Bronze and iron hook clasps with the central bar (fig. 70: IV) or in openwork in the shape of a stylized

⁷⁷⁶ Guštin/Preložnik 2005, 138 ss, sl. 22–25.

na Magdalenski gori in predstavljajo tretjino vseh tovrstnih primerkov s teritorija dolenske halštatske skupnosti (sl. 70: III). Od železnih rombičnih spon je Magdalenska gora prispevala tretjino vseh izdelkov (sl. 70: I), od železnih pravokotnih primerkov dobro šestino (sl. 70: II), od predrtih spon zgodnjelatske sheme pa kar dve tretjini (sl. 70: VI). Bronaste in železne kavljaste spone s sredinsko prečko (sl. 70: IV) ter predrte v obliki stilizirane ptice (sl. 70: V) ali pa pravokotne iz narebrenne bronaste pločevine (sl. 66: 21) pa se niso širše uveljavile. Na tem najdišču sta izpričana tudi dva primerka pozno-latskih pasnih spon.⁷⁷⁷

4.5 ŽEZLA IN RAŽNJI

4.5.1 ŽEZLA

Tipološke značilnosti. Izraz žezlo uporabljamo za označevanje paličic, ki se na eni strani zaključujejo v konico, na drugi pa v kroglasto ali gobasto glavico, vendar njihova funkcija ni povsem razjasnjena. Egg zanje uporablja izraz *stilus*, ker so na pogled podobni rimskim pisalom.⁷⁷⁸ Na sliki 71 so prikazani vsi znani kosi z Magdalenske gore,⁷⁷⁹ nekateri med njimi imajo bronaste objemke (sl. 71: 4, 5, 7) za pritrjevanje na nekaj, kar se ni ohranilo. Trije so železni, eden je prevlečen s črno stekleno glazuro z rumeno spiralo (sl. 71: 1), druga dva imata bronasto glavico in železen pecelj (sl. 71: 2, 3). Ostali primerki so bronasti in imajo pecelj šesterokotnega ali osmerokotnega preseka ter ornamentiran vrat z vrezanim okrasom, ki ga sestavljajo različni geometrijski motivi, največkrat se ponovi motiv IIIXIII. V enem primeru je okrašena tudi glavica, in sicer z okroglimi vdolbinicami (sl. 71: 5). Mednje je moč uvrstiti še bronast fragment, ki po mnogokotnem preseku in vrezanem okrasu spominja na tovrstne paličice, le da ima na vratu še niz buncic (sl. 71: 9).

Lega in kontekst. Za žezlo s črno-rumeno stekleno prevleko in železnim jedrom (sl. 71: 1) se ne ve, kateremu grobu je pripadalo. Železni primerek z bronasto glavico (sl. 71: 2) je objavljen skupaj s sekuro in nožem kot pridatek groba IV/11 s Prelog, vendar ga Goldberg v tem kontekstu ne omenja. Prav tako ni zabeležil bronastega fragmenta z mnogokotnim presekom ter okrasom z buncicami (sl. 71: 9), ki je objavljen med prdatki ženskega groba X/75 s Prelog. Z Goldbergovimi zapiski se ne sklada niti grobna celota IV/43 s Prelog, v kateri nastopa žezlo z železnim pecljem in bronasto kapico (sl. 71: 3), inventarizirano pa je v zbirki Narodnega muzeja

⁷⁷⁷ Hencken 1978, Fig. 226i; Tecco Hvala/Dular/Kocuvan 2004, T. 158: 8.

⁷⁷⁸ Egg 1999, 333 s.

⁷⁷⁹ Hencken 1978, Fig. 47c, 85a, 144h, 359k, 365b; Tecco Hvala/Dular/Kocuvan 2004, T. 25: 18, 61B: 5, 84: 4, 148: 11.

bird (fig. 70: V) as well as rectangular clasps of ribbed sheet bronze (fig. 66: 21), on the other hand, are generally less frequent. The clasps of Magdalenska gora thus show the community to have been open to novelties and to have played an important role in the Late Hallstatt period. In addition, the site also revealed two Late La Tène belt clasps.⁷⁷⁷

4.5 MACES AND SPITS

4.5.1 MACES

Typological characteristics. The term mace is used to designate rods terminating in a point at one end and a spherical or mushroom-shaped head at the other end, whereby their function is not quite clear. For these objects, Egg uses the term *stilus* due to their similar appearance to the Roman writing implements.⁷⁷⁸ The maces found at Magdalenska gora are shown on figure 71.⁷⁷⁹ Some have bronze clips (fig. 71: 4, 5, 7) for attachment to an unpreserved object. Three of them are iron, one entirely coated with a black glaze with a yellow spiral (fig. 71: 1), the other two with the head made of bronze (fig. 71: 2, 3). Others are made entirely of bronze, with shanks of hexagonal or octagonal cross-sections and necks with incised decoration. The latter consists of various geometric motifs, most often that of IIIXIII. One mace bears decoration also on the head, consisting of shallow impressions (fig. 71: 5). There is also a bronze fragment with a polygonal cross-section of the shank and incised decoration, as well as indented rings on the neck (fig. 71: 9).

Position and context. The iron mace coated with a black-yellow glaze (fig. 71: 1) is without known grave provenance. The iron example with the bronze head (fig. 71: 2) was published together with an axe and a knife as the goods of Grave IV/11 from Preloge, though it is not mentioned in that context by Goldberg. He also did not mention the bronze fragment of polygonal cross-section and decorated with indented rings on the neck (fig. 71: 9), which is published among the goods of female Grave X/75 from Preloge. Further inconsistency can be observed for Grave IV/43 from Preloge, in which an iron mace with bronze head was published as part of its goods (fig. 71: 3), though it is kept in the collection of the National Museum in Ljubljana. For the richest, Grave V/29 at Laščik, which contained two Negova helmets (fig. 54), Goldberg mentions a small bronze rod (fig. 71: 5). Maces formed part of the most elite warrior

⁷⁷⁷ Hencken 1978, Fig. 226i; Tecco Hvala/Dular/Kocuvan 2004, T. 158: 8.

⁷⁷⁸ Egg 1999, 333 f.

⁷⁷⁹ Hencken 1978, Figs. 47c, 85a, 144h, 359k, 365b; Tecco Hvala/Dular/Kocuvan 2004, T. 25: 18, 61B: 5, 84: 4, 148: 11.

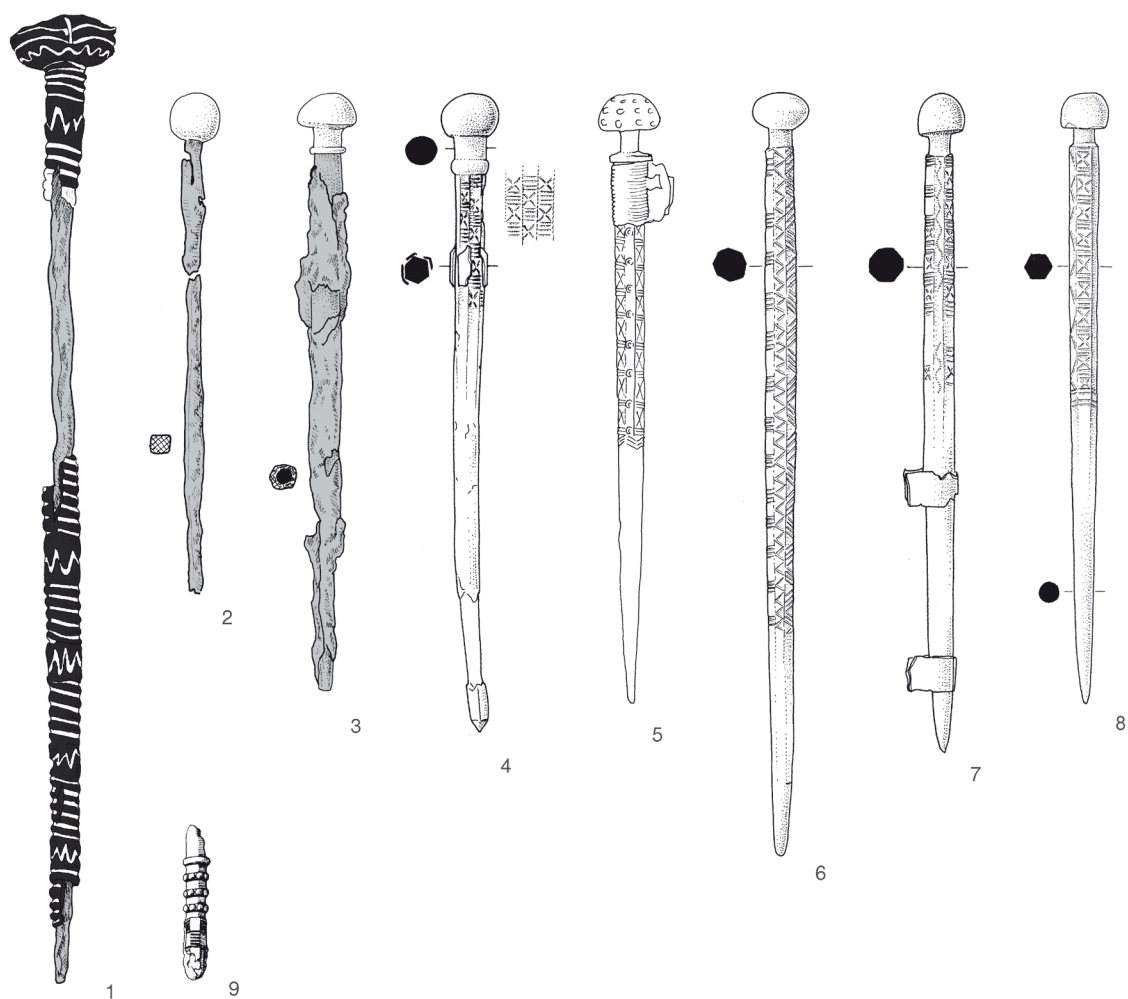

Sl. 71: Žezla z Magdalenske gore. 1 = železno jedro s stekleno prevleko; 2, 3 = železo in bron; 4–9 = bron. M. = 1:2.

Fig. 71: Maces from Magdalenska gora. 1 = iron core with glass overlay; 2, 3 = iron and bronze; 4–9 = bronze. Scale = 1:2.

1 – najdba brez grobne celote v PM / find without preserved context kept in the PM; 2 – Preloge, gr. IV/11; 3 – Preloge, gr. IV/43;

4 – najdba brez znane grobne celote v NMS / find without preserved context kept in the NMS; 5 – Laščik, gr. V/29;

6 – Preloge, gr. 2/13; 7 – Preloge, gr. 2/77; 8 – Preloge, gr. 13/55; 9 – Preloge, gr. X/75.

v Ljubljani. Le v najbogatejšem grobu V/29 z Laščika, ki je med drugim vseboval dve negovski čeladi (sl. 54), Goldberg v opisu izrecno govori o bronasti paličici (sl. 71: 5). V najelitnejših opravah jih zasledimo tudi v gomilah 2 in 13 na Prelogah (sl. 71: 6–8) – v grobu 2/13 skupaj z dvogrebenasto čelado in bogato konjsko opremo, v grobu 13/55 pa s čelado z narebreno kaloto in figuravno okrašeno situlo, medtem ko je grobni sestav 2/77 nekoliko skromnejši, saj je poleg žezla vseboval le še tulasto sekiro, sulično ost, železne pasne obročke in glinasto posodo (sl. 72).

Razširjenost in časovni okvir. O tovrstnih paličicah z območja dolenske halštatske skupnosti je razpravljal Egg,⁷⁸⁰ njegov seznam bi lahko dopolnili še z nekaterimi

⁷⁸⁰ Egg 1999, 333 s, Abb. 13.

outfit also in Tumuli 2 and 13 at Preloge (fig. 71: 6–8) – in Grave 2/13 together with a double-crested helmet and rich horse gear, in Grave 13/55 with a helmet with a ribbed skull and situla with figural decoration, while the goods in Grave 2/77 were less rich, containing a mace, a socketed axe, spearhead, iron belt rings and a clay vessel (fig. 72).

Distribution and time frame. The rods from the area of the Dolenjska Hallstatt community were discussed by Egg,⁷⁸⁰ whereby his list can be completed with additional sites. Iron rods were found at Vače⁷⁸¹ and Libna,⁷⁸² at

⁷⁸⁰ Egg 1999, 333 f, Abb. 13.

⁷⁸¹ Stare F. 1955a, T. 39: 6 and one unpublished example in NHMW, which is inserted in a bronze sheath.

⁷⁸² Guštin 1976, T. 20: 6.

Gom. / Gr. Tum. / Gr.	Pokop / Burial rite	Spol / Starost Sex / Age	Pokop konja / Horse burial	Žezlo / Mace	Ražnji / Spit	Fibule / Fibulae	Narokvice / Armrings	Pasne spone / Belts	Pasni okovi / Belt attachments	Fe obročki / Fe rings	Čelada / Helmet	Sekire / Axes	Sulice / Spears	Pušice / Arrows	Meč / Sword	Noži / Knives	Dereze / Clampons	Brus / Whetstone	Konjska oprema / Horse gear	Lončenina / Pottery	Košten tul / Bone tube	Bronasto posodje / Bronze vessels	
P 2/13	S	M	x	1				2	x		1	1	2	50				2	1	x	2		4
L V/29	S	M+M	x	1			2	2	x		2		2+4		1	1		1	x				4
P 13/55	S	M		1		2		1	x		1	1	1			1					2		2
P 2/77	S	M		1						x		1	1								1		
L V/6-7	S	M	x		br	2+1		2	x	x	1		2+2			1			x				3
P 2/38	S	M			br		2	1	x		1	1	1	x						1			1
P 2/b	S	M			Fe	2							2?										1

Sl. 72: Struktura pridatkov v grobovih z žezli in ražnji na Magdalenski gori.
Fig. 72: Structure of goods in the graves with maces and spits at Magdalenska gora.

najdišči. Taki železni izdelki so znani z Vač⁷⁸¹ in Libne,⁷⁸² iz Velikih Malenc, kjer nastopa v grobu s skladasto čelada iz časa stopnje Podzemelj 2,⁷⁸³ v Stični pa v grobu 48/72, ki je datiran v stopnjo Stična 1.⁷⁸⁴

Posamični železni primerki z bronasto kapico so razen z Magdalenske gore (sl. 71: 2, 3) znani z Vač⁷⁸⁵ in iz gomile na Osrečju v okolici Velikega Vinjega vrha (Šmarjete)⁷⁸⁶ ter iz Stične.⁷⁸⁷

Večina bronastih primerkov z okrašenim vratom mnogokotnega preseka pa je bila najdena na Magdalenski gori (sl. 71: 4–8), kjer njihovo kronološko mesto v certoski in negovski stopnji ni sporno. V ta časovni okvir se uvrščata sorodna primerka iz Volčjih Njiv⁷⁸⁸ in Novega mesta, kjer je bil najden v grobu z ilirskima čeladama iz zgodnje negovske faze.⁷⁸⁹ Srečamo jih tudi v Stični – v dveh grobovih, odkritih med izkopavanji vojvodinje Mecklenburške, ter v grobu 48/33, ki ga Teržanova postavlja na prehod v mlajše halštatsko obdobje.⁷⁹⁰ Slednji

⁷⁸¹ Stare F. 1955a, T. 39: 6 in neobjavljeni kos v NHMW, ki je vtaknjen v bronast pločevinast tulec.

⁷⁸² Guštin 1976, T. 20: 6.

⁷⁸³ Stare V. 1960–1961, 52, T. 2: 1.

⁷⁸⁴ Gabrovec et al. 2006, T. 37: 10; Gabrovec/Teržan 2008, 183, sl. 42.

⁷⁸⁵ Neobjavljeno, NHMW inv. št. 71272.

⁷⁸⁶ Dular A. 1991, T. 45: 4.

⁷⁸⁷ Wells 1981, 85, Fig. 184a.

⁷⁸⁸ Gabrovec 1956, T. 2: 1.

⁷⁸⁹ *Kapiteljska njiva, gr. 7/19*: Egg 1999, Abb. 7: 6.

⁷⁹⁰ Wells 1981, Fig. 30, 117a; Gabrovec et al. 2006, T. 25:

1. Teržanova domneva, da primerek iz stiškega groba 48/33 predstavlja import ali domač posnetek, narejen po vzoru skitskih igel, vendar analogije, ki jih navaja, niso najbolj prepričljive (Teržan 2008, 287 ss, op. 264, sl. 42).

Velike Malence in the grave with a bowl-shaped helmet from the Podzemelj 2 phase⁷⁸³ and at Stična in Grave 48/72 dated to the Stična 1 phase.⁷⁸⁴

Apart from Magdalenska gora (fig. 71: 2, 3), individual iron examples with a bronze head are known from Vače,⁷⁸⁵ from a tumulus at Osrečje near Veliki Vinji vrh (Šmarjete)⁷⁸⁶ and from Stična.⁷⁸⁷

Most of the bronze rods with a decorated neck and polygonal cross-section were found at Magdalenska gora (fig. 71: 4–8), where their date into the Certosa and Negova phases is undisputed. This time frame can also be attributed to the similar examples from Volčje Njive⁷⁸⁸ and Novo mesto, the latter found in a grave together with two Illyrian helmets from the Early Negova phase.⁷⁸⁹ They were also found at Stična, in two graves dug by the Duchess of Mecklenburg and in Grave 48/33, dated by Teržan to the transition into the Late Hallstatt period.⁷⁹⁰ The rod from the latter grave, with an indented ring on the neck and hexagonal cross-section, is the closest parallel for the fragment from Magdalenska gora published as part of Grave X/75 from Preloge (fig. 71: 9).

⁷⁸³ Stare V. 1960–1961, 52, T. 2: 1.

⁷⁸⁴ Gabrovec et al. 2006, T. 37: 10; Gabrovec/Teržan 2008, 183, Abb. 42.

⁷⁸⁵ Unpublished, NHMW Inv. No. 71272.

⁷⁸⁶ Dular A. 1991, T. 45: 4.

⁷⁸⁷ Wells 1981, 85, Fig. 184a.

⁷⁸⁸ Gabrovec 1956, T. 2: 1.

⁷⁸⁹ *Kapiteljska njiva, Gr. 7/19*: Egg 1999, Abb. 7: 6.

⁷⁹⁰ Wells 1981, Figs. 30, 117a; Gabrovec et al. 2006, T. 25: 1. According to Teržan, the example from Grave 48/33 at Stična is either an import or an imitation of Scythian pins. However, the cited analogies are not convincing (Teržan 2008, 287 ff, n. 264, Abb. 42).

predstavlja po okrasu z buncicami na vratu šesterokotnega preseka najboljšo paralelo za fragment z Magdalenske gore, objavljen v sklopu groba X/75 s Prelog (sl. 71: 9).

Grob s skledasto čelado iz Velikih Malenc priča, da se take paličice na Dolenjskem pojavijo že v stopnji Podzemelj 2, in sicer v železni izvedbi. Iz mlajšega halštatskega obdobja so znani bronasti primerki, najmlajši med njimi sta betičasti paličici iz novomeškega groba 7/19 s Kapiteljske njive v Novem mestu ter iz groba V/29 z Laščika na Magdalenski gori, slednja ima glavico okrašeno s plitvimi vdolbinicami (morebiti za nekakšne vložke iz paste, koral ali kaj podobnega, ki so kasneje izpadli).

Tovrstni predmeti so večinoma pripadali najprestižnejšim bojevnikiškim opravam, kar jim daje poseben simbolni pečat. Čeprav ni v celoti razjasnjeno, za kaj so jih praktično uporabljali, pa jih glede na rang lastnikov lahko interpretiramo kot izraz moči oz. kot žezla dolenjskih poglavarjev ali poveljnikov. Nemara bi podobno vlogo lahko pripisali tudi tistim večglavim iglam s trombastim zaključkom, ki so zelo dolge in nastopajo v elitnih moških grobovih iz starejšega halštatskega obdobja na Dolenjskem (obravnavam jih v poglavju o iglah).

Železne in bronaste betičaste palice ali kije zasledimo v bojevnikiških opravah 7. in 6. st. pr. n. št. v Etruriji, Abruzzih in Picenumu,⁷⁹¹ kjer so nekatere okrašene s tavširanjem; njihovo funkcijo pa razlagajo v smislu poveljniških palic.⁷⁹² Tudi magdalenskogorski unikatni primerek (sl. 71: 1)⁷⁹³ ima še najboljšo analogijo v sceptru z železnim jedrom in stekleno oblogo iz picenskega Campovalana.⁷⁹⁴ Morebiti so imela dolenjska žezla podoben pomen kot srednjeitalski izdelki in so od tam prevzeli idejo ter jo po svoje preoblikovali.

4.5.2 RAŽNJI ALI OBOLOI

Drug tak statusni pridelek bogatih moških grobov predstavljajo ražnji. O njih so pisali že mnogi avtorji,⁷⁹⁵

⁷⁹¹ Stary 1981, 88, 216 s, 263 s, 284, 461 s, W 53, Karte 34.

⁷⁹² Sgubini Moretti 1992, 184; *Eroi e regine. Piceni Popolo d'Europa* 2001, 81, 102, 111, Fig. 53, Kat. št. 435, 453.

⁷⁹³ Na enak način sta izdelana živalska protoma iz ženskega groba IV/24 s Prelog, kjer ju Goldberg ne omenja (Hencken 1978, 21, Fig. 62c,d); imata železno jedro in črno-rumeno stekleno glazuro in bi lahko pripadala k temu žezlu oz. sceptru.

⁷⁹⁴ *Eroi e regine. Piceni Popolo d'Europa* 2001, 269: Kat. št. 556, Fig. 77.

⁷⁹⁵ Stary 1979; Frey 1980b, 97 s; Kimmig 1983, 43, Abb. 38; Teržan 1990a, karta 25; von Hase 1992, 260 ss, Abb. 25; Egg 1996, 139 ss, Abb. 81–86; Kohler 2000; Tomedi 2002, 133 ss; Teržan 2004a; *ead.*, 2008, 305 ss, sl. 53; Gleirscher 2009.

The grave with a bowl-shaped helmet from Velike Malence shows that such rods, made of iron, appeared in Dolenjska already in the Podzemelj 2 phase. Of a Late Hallstatt date are the bronze examples, with the latest being two maces from Grave 7/19 from Kapiteljska njiva in Novo mesto and Grave V/29 from Laščik, the head of the latter decorated with shallow impressions (possibly for inlays of glass paste, coral or similar material that later fell out).

Rods like those discussed above were mostly formed part of the most prestigious warrior outfit, which gives them a highly symbolic meaning. Although it is not entirely clear what they were used for, the rank of their owners indicates an expression of power and the rods could thus be interpreted as maces of the chieftains or commanders of Dolenjska. A similar role could also be attributed to the multi-knobbed pins with a trumpet guard, which are very long and were found in the graves of the highest-ranking males from the Early Hallstatt period in Dolenjska (they are discussed below in the chapter on pins).

Iron and bronze maces or clubs formed part of the warrior outfit of the seventh and sixth centuries BC in Etruria, Abruzzi and Picenum,⁷⁹¹ some of them with inlaid decoration. They are interpreted as commander's rods.⁷⁹² The closest parallel for the unique example from Magdalenska gora (fig. 71: 1),⁷⁹³ in the manner of production, can be found in a mace with an iron core and glass coat from Campovalano in Picenum.⁷⁹⁴ The maces of Dolenjska might have had a similar significance as the central Italian products and the idea of making such objects, though in local version, also came from there.

4.5.2 SPITS OR OBOLOI

Another type of objects that indicate high status in rich male graves is spits. They have been discussed by numerous authors,⁷⁹⁵ wherefore they will be presented

⁷⁹¹ Stary 1981, 88, 216 f, 263 f, 284, 461 f, W 53, Karte 34.

⁷⁹² Sgubini Moretti 1992, 184; *Eroi e regine. Piceni Popolo d'Europa* 2001, 81, 102, 111, Fig. 53, Cat. Nos. 435, 453.

⁷⁹³ Made in the same manner were two animals protomes from female Grave IV/24 at Preloge, not mentioned by Goldberg (Hencken 1978, 21, Fig. 62c,d). They have an iron core with a black-yellow glaze, and could be the decoration of the above-mentioned mace or sceptre.

⁷⁹⁴ *Eroi e regine. Piceni Popolo d'Europa* 2001, 269: Cat. No. 556, Fig. 77.

⁷⁹⁵ Stary 1979; Frey 1980b, 97 f; Kimmig 1983, 43, Abb. 38; Teržan 1990a, map 25; von Hase 1992, 260 ff, Abb. 25; Egg 1996, 139 ff, Abb. 81–86; Kohler 2000; Tomedi 2002, 133 ff; Teržan 2004a; *ead.*, 2008, 305 ff, Abb. 53; Gleirscher 2009.

zato bom osvetlila le kontekste, v katerih nastopajo na Magdalenski gori (sl. 72 in 73).⁷⁹⁶

Železen raženj s tordiranim vratom (sl. 73: 1) pripada delno rekonstruiranemu grobnemu sestavu 2/b s Prelog, ki je vseboval bronasto figuralno okrašeno situlo, dve samostrelni fibuli z zaključkom noge v obliki naprej gledajočih ovnovih glavic, po nekaterih podatkih pa menda še dve železni sulični osti.

Bronast raženj z okroglo zanko in vrezano oznako IIIIXIII na vratu (sl. 73: 2) je v grobu 2/38 s Prelog ležal pod bronasto kelihasto posodo. Pokojnik v tem grobu je imel na kolenih dvogrebenasto čelado, k njegovi opravi so spadali bronasta pravokotna pasna spona, dve votli narokvici in orožje, priložena pa mu je bila še glinasta posoda bojda z zlatim okrasom. V grobu konjenika V/6-7a-7 z Laščika sta bronasta ražnja (sl. 73: 3, 4) po pričevanju Goldberga ležala pod čelado dvogrebenastega tipa, toda namesto nje je objavljen fragment krajca negovske čelade. Te grobne celote z Magdalenske gore lahko datiramo v čas certoške ali zgodnje negovske stopnje.

Teržanova domneva, da so imeli ražnji ali *oboloi* v halštatskih skupnostih dvojni pomen; poleg ritualnega oz. statusnega so morebiti predstavljali neke vrste predmonetarno obliko plačilnega sredstva. Ražnji z rombičnim držajem so bili v obtoku v severnojadranskem zaledju, ražnji z obročastim zaključkom pa v srednjeevropskem prostoru. Skupaj jih zasledimo na najdiščih, kot so Hallstatt, Strettweg, Magdalenska gora in Stična,⁷⁹⁷ torej na stičiščih "jugozahodnega" in "severovzhodnega" sistema, kar kaže na to, da so imeli ti kraji pomembno vlogo v menjavni dobrin.

4.6 IGLE

Tipološke značilnosti. Igel v zapuščini magdalensko-gorske halštatske skupnosti ni prav veliko, kljub temu so zanimive zaradi raznolikosti. S posamičnimi primerki so zastopane drobna igla z bikonično glavico in narezanim vratom (sl. 74: 2), večglava igla s trombastim zaključkom (sl. 74: 1) ter manjša s tremi vozli (sl. 74: 5). Znani sta tudi dve zviti igli z drobno vazasto glavico (sl. 74: 8, 9). Več igel ima en konec razkovan in zvit v zanko, med njimi

⁷⁹⁶ Hencken 1978, Fig. 110a,b; Tecco Hvala/Dular/Kocuvan 2004, 29, 39, T. 9: 3, 35: 16.

⁷⁹⁷ Egg 1996, 139 ss, Abb 83, 86; Teržan 2004a; ead. 2008, 305 ss, sl. 53.

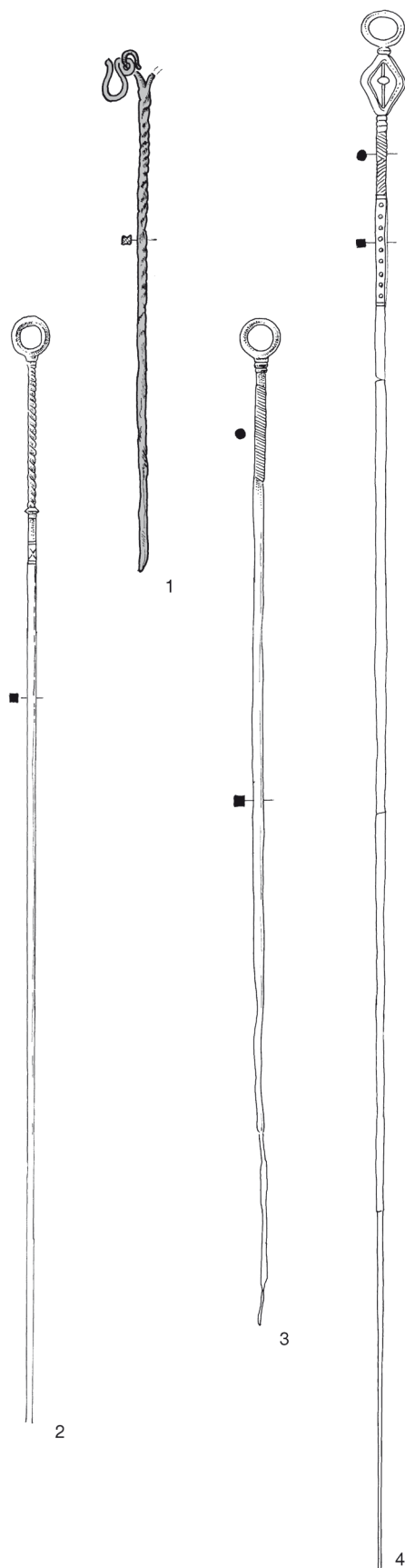

Sl. 73: Ražnji z Magdalenske gore. 1 = železo; 2-4 = bron.

M. = 1:6.

Fig. 73: Spits from Magdalenska gora. 1 = iron; 2-4 = bronze. Scale. = 1:6.

1 – Preloge, gr. 2/b; 2 – Preloge, gr. 2/38; 3, 4 – Laščik, gr. V/6-7a-7.

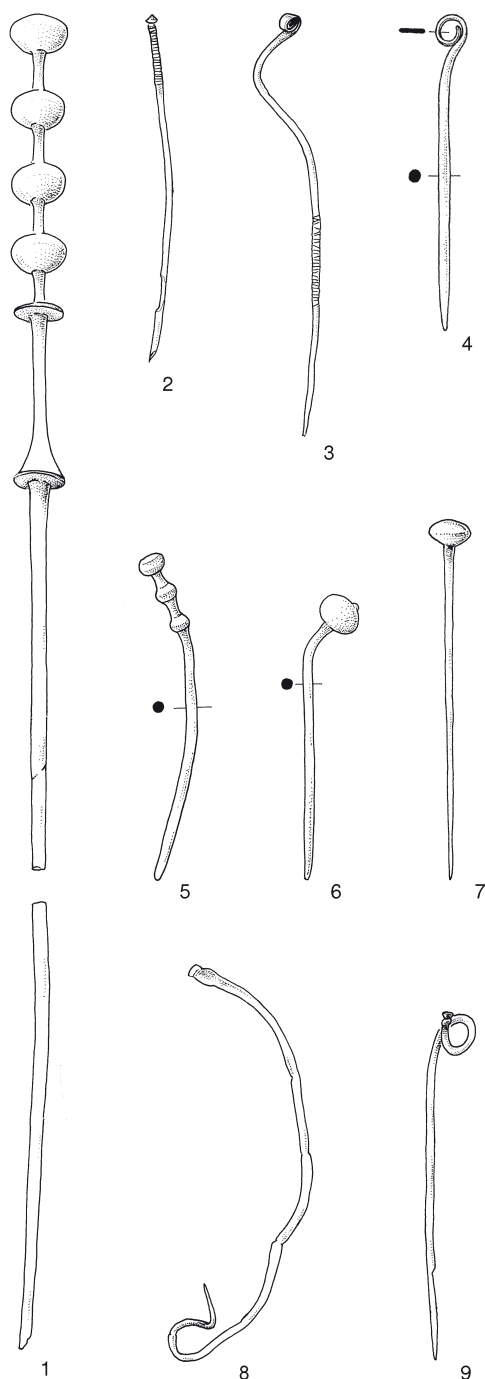

Sl. 74: Tipi bronastih igel z Magdalenske gore. M. = 1:2.

Fig. 74: Types of bronze pins from Magdalenska gora. Scale = 1:2.

1 – Preloge, gr. VI/3; 2, 3 – najdbe brez znanih grobnih celot v PM / finds without preserved contexts kept in the PM; 4 – Voselca, gr. 2/8; 5 – Preloge, gr. 2/56; 6 – najdba brez znane grobne celote v NMS / find without preserved context kept in the NMS; 7 – Laščik, gr. V/2; 8 – Preloge, gr. IV/13; 9 – Preloge, gr. IV/37.

here only in the grave contexts at Magdalenska gora (figs. 72 and 73).⁷⁹⁶

An iron spit with a twisted neck (fig. 73: 1) belongs to a partly reconstructed group from Grave 2/b from Preloge, which consisted of a bronze situla with figural decoration, two crossbow fibulae with the foot terminating in forward-facing ram's heads, while some sources also cite two iron spearheads.

The bronze spit with a round loop and IIIIII incised on the neck (fig. 73: 2) lay in Grave 2/38 from Preloge under a bronze goblet-like vessel. The deceased had a double-crested helmet at the knees, with the grave group further consisting of a bronze rectangular belt clasp, two hollow armlets, weapons and a clay vessel reportedly with gold decoration. In horseman's Grave V/6–7a–7 at Laščik, Goldberg noted two bronze spits (fig. 73: 3, 4) found under a double-crested helmet, while the publication of the grave presents a brim fragment of a Negova helmet. The above-cited grave groups can be dated to the Certosa or Early Negova phases.

Teržan supposes a double meaning for these spits or *oboloi* within the Hallstatt communities. Apart from the ritual or status symbols, they may have represented a sort of a premonetary mean of payment. Spits with a rhombic handle were in circulation in the hinterland of the northern Adriatic, while the spits with a loop terminal were used in the central European area. They were found together at sites such as Hallstatt, Strettweg, Magdalenska gora and Stična,⁷⁹⁷ which is on the meeting point of the "south-western" and "north-eastern" systems. This in turn reveals the importance of these sites in the exchange of goods.

4.6 PINS

Typological characteristics. The legacy of the Magdalenska gora Hallstatt community does not include many pins, but they are nevertheless interesting due to their variety. There are individual examples of small pins with a biconical head and carved neck (fig. 74: 2), multi-knobbed pins with a trumpet guard (fig. 74: 1) and small pins with three knobs (fig. 74: 5). Also known are two bent pins with a small vase-shaped head (fig. 74: 8, 9). Several pins have one end hammered out and rolled into a loop, whereby some of these pins are slenderer and longer and others shorter and thicker with a wider loop (fig. 74: 3, 4). There are also some examples of spherical- or disc-headed pins (fig. 74: 6, 7).

Position and context. The pin with a biconical head and carved neck (fig. 74: 2) was published together with

⁷⁹⁶ Hencken 1978, Fig. 110a,b; Tecco Hvala/Dular/Kocuvan 2004, 29, 39, 125, 132, T. 9: 3, 35: 16.

⁷⁹⁷ Egg 1996, 139 ff, Abb 83, 86; Teržan 2004a; ead. 2008, 305 ff, Abb. 53.

so ene gracilnejše in daljše, druge krajše in debelejše in imajo širšo zanko (sl. 74: 3, 4); nekaj primerkov pa ima kroglasto ali diskasto glavico (sl. 74: 6, 7).

Lega in kontekst. Iгла z bikonično glavico in narezanim vratom (sl. 74: 2) je skupaj z dvema primerkoma z zankasto uvito glavico (sl. 74: 3) objavljena med najdbami iz zbirke vojvodinje Mecklenburške brez znanih podatkov o okoliščinah odkritja.⁷⁹⁸ Drugi primerki igel z zankasto uvito glavico (sl. 74: 4) so zabeleženi v skeletnih grobovih z ženskim oz. dekliškim nakitom (sl. 75: B).⁷⁹⁹ V zanesljivejših grobnih celotah jih zasledimo v kombinaciji s kačasto in drobno ločno fibulo ter trakastimi ali certoškimi fibulami vrst II in V, valjastimi uhani in polno ulitimi ali votlimi zapestnicami. K opravama iz grobov 13/36 s Prelog in 2/8 z Voselce je bil pridan še sceptor; v grobnem sestavu 13/36 pa poleg ženskega okrasja nastopajo tudi moški pridatki, med katere bi lahko uvrstili železno rombično pasno spono, nož in brusni kamen. Dve igli z zankasto uvito glavico sta objavljeni med najdbami domnevno žarnega groba VII/28 z izkopavanj vojvodinje Mecklenburške, vendar sta sestava pridatkov in način pokopa precej nenavadna. Vprašljiva sta tudi konteksta z iglama z drobno vazasto glavico.⁸⁰⁰ V sklopu grobne celote IV/13 s Prelog (sl. 74: 8) je taka igla objavljena skupaj s kačasto fibulo in ozkim trakastim uhanom, medtem ko Goldberg omenja v tem grobu zgolj fibulo. O grobu IV/37 iz iste gomile je zapisal, da je vseboval železen nož, zlomljeno fibulo in eno zvito iglo, v objavi pa nastopata dve – velika igla, ukrivljena v obliki pastirske palice viniškega tipa, ter majhna zvita igla z vazasto glavico (sl. 74: 9), razen tega še kačasta fibula s ploščico in nož.

Po Goldbergovih podatkih je bila v žganemu grobu VI/3 s Prelog najdena 35 cm dolga in lepo izdelana igla s štirimi vozli in trombastim zaključkom (sl. 74: 1). Ležala naj bi skupaj z brusnim kamnom in bronastim gumbom tik pod ploščo ob kamniti skrinji, ki je vsebovala posodo, okrašeno z bronastimi žeblički in še eno navadno.⁸⁰¹ Drugo večglavo iglo, ki je precej manjša (8,6 cm) in ima le tri drobne vozle (sl. 74: 5 in sl. 75: A2), pa je našel Pečnik v skeletnem grobu 2/56 na Prelogah skupaj s certoškima fibulama vrste XIII in bronastim obročkom.⁸⁰²

Primerki igel s kroglasto glavico (sl. 74: 7 in sl. 75: C) nastopajo med najdbami iz Mecklenburške zbirke.⁸⁰³ Ker se objavljeni grobni sestavi ne ujemajo docela z navedbami v Goldbergovih zabeležkah, si oglejmo, kaj je ta o njih zapisal. O grobu X/38 s Prelog poroča, da je vseboval slabo ohranjeno okostje, ki je imelo na vsakem

two roll-headed pins (fig. 74: 3) among the finds excavated by the Duchess of Mecklenburg without known find data.⁷⁹⁸ Other roll-headed examples (fig. 74: 4) were recorded in inhumation graves with woman's or girl's jewellery (fig. 75: B).⁷⁹⁹ They appear in more reliable grave groups in combination with a serpentine and small bow fibula, as well as flat bow fibulae and Types II and V Certosa fibulae, cylindrical earrings and solid or hollow bracelets. The costume in Graves 13/36 from Preloge and 2/8 from Voselca included a sceptre; while Grave 13/36 also revealed male attributes such as an iron rhombic belt clasp, a knife and a whetstone. Two roll-headed pins are published as part of urn Grave VII/28 excavated by the Duchess, though the composition of the goods and burial rite is rather unusual. Also questionable are the two contexts with vase-headed pins.⁸⁰⁰ Such a pin is published within Grave IV/13 from Preloge (fig. 74: 8) together with a serpentine fibula and a narrow band earring, though Goldberg only mentions the fibula. For Grave IV/37 from the same tumulus, Goldberg noted an iron knife, a broken fibula and a bent pin, while the publication lists two pins – a large bent one in the shape of a shepherd's cane of the Vinica type and a small bent vase-headed pin (fig. 74: 9), as well as a serpentine fibula with a plate and a knife.

According to Goldberg, the cremation Grave VI/3 from Preloge revealed a 35cm long and beautifully made pin with four knobs and a trumpet guard (fig. 74: 1). It reportedly lay just under a stone slab beside the stone cist together with a whetstone and a bronze knob, whereby the stone cist contained a vessel decorated with bronze studs and one ordinary vessel.⁸⁰¹ The other multi-knobbed pin, which is much shorter (8.6cm) and only has three knobs (fig. 74: 5 and fig. 75: A2), was found by Pečnik in inhumation Grave 2/56 at Preloge together with two Type XIII Certosa fibulae and a bronze ring.⁸⁰²

The Mecklenburg collection also includes examples of spherical-headed pins (fig. 74: 7 and fig. 75: C).⁸⁰³ The published grave groups, however, do not entirely correspond to Goldberg's notes. Goldberg, for example, noted that Grave X/38 from Preloge contained a poorly preserved skeleton with a spiral bracelet on each wrist, but also a hair pin, a serpentine fibula with a disc and a vessel. Grave X/67 from the same tumulus was noted as that of a child containing scarce remains of a skeleton as well as a serpentine fibula with two bracelets hanging from it, a bow fibula, two buttons, four small pendants, two rings and several blue glass beads. He also mentions a pin among the goods of inhumation Grave

⁷⁹⁸ Hencken 1978, Fig. 364r-s.

⁷⁹⁹ Hencken 1978, Fig. 248f,i, 339e; Tecco Hvala/Dular/Kocuvan 2004, 20E: 2, 37A: 13, 62B: 3, 76: 24, 134A: 7.

⁸⁰⁰ Hencken 1978, Fig. 49b, 78b.

⁸⁰¹ *Ibid.*, Fig. 176a.

⁸⁰² Tecco Hvala/Dular/Kocuvan 2004, T. 49B: 3.

⁸⁰³ Hencken 1978, Fig. 103f, 330d, 352i, 359l.

⁷⁹⁸ Hencken 1978, Fig. 364r-s.

⁷⁹⁹ Hencken 1978, Figs. 248f,i, 339e; Tecco Hvala/Dular/Kocuvan 2004, 20E: 2, 37A: 13, 62B: 3, 76: 24, 134A: 7.

⁸⁰⁰ Hencken 1978, Figs. 49b, 78b.

⁸⁰¹ *Ibid.*, Fig. 176a.

⁸⁰² Tecco Hvala/Dular/Kocuvan 2004, T. 49B: 3.

⁸⁰³ Hencken 1978, Figs. 103f, 330d, 352i, 359l.

Gom. / Gr. Tum. / Gr.	Pokop / Burial rite	Spol / Starost Sex / Age	Tipi igel / Types of pins		Fibule / Fibulae	Uhani / Earrings	Steklene jagode / Glass beads	Jantar / Amber	Obeski / Pendants	Zapestnice / Bracelets	Nanožnice / Anklets	Scepter / Sceptre	Pasma spona / Belt	Nož / Knife	Brus / Whetstone	Lončenina / Pottery	Vijčki / Spindle whorls	
			Št. igel / No. of pins															
P VI/3	C	M	A1	1											1	2		
P 2/56	S	?	A2	1	2													
P X/50	S	F	B	1	2					2+1								
P 2/81	S	I		1	2		x	x		2								
P 2/39	S	F		1	2	7	x			2						1	4	
P 13/36	S	F+M?		1	2	2	x	x		4	2	1	Fe	1	1	2		
V 2/8	S	F		1		6			x			1						
P 2/17	S	F		1	2													
P X/38	S	F		C	1	1				2							1	
P X/67	S	I	1		2		x		x	2								
P X/75	S	F	1		1	4	x	x		2		1						
L V/2	S	F	1		1	4-6	x	x		2+2								

Sl. 75: Struktura pridatkov v grobovih z bronastimi iglami na Magdalenski gori.

Fig. 75: Structure of goods in the graves with bronze pins at Magdalenska gora.

A1 = večglava igla s trombastim zaključkom / many-knobbed pin with trumpet guard,

A2 = večglava igla brez zaključka / pin with three knobs,

B = igla z zankasto uvito glavico / roll-headed pin,

C = igla s kroglasto glavico / spherical-headed pin.

zapestju po eno spiralno zapestnico, razen tega še lasno iglo, kačasto fibulo z diskom in eno posodo. Grob X/67 iz iste gomile pa naj bi bil otroški; v njem so bili na skromnih ostankih okostja najdeni kačasta fibula, na kateri sta viseli zapestnici, zraven še ločna fibula, majhna igla, dva gumba, štirje majhni obeski in dva obročka ter nekaj modrih steklenih jagod. Iglo omenja tudi med pridatki skeletnega groba X/75 iz te gomile, poleg nje pa kačasto fibulo, bronasti zapestnici, dva uhana, steklene in jantarne jagode ter bronast scepter in obroček v obliki sonca. O grobu V/2 z Laščika pa je zapisal, da je bilo pri okostju najdenih šest uhanov (v drugi zabeležki omenja le štiri), jantarne in steklene jagode, certoška fibula, na vsakem zapestju po ena zapestnica ter en par zapestnic na prsih skupaj z 9 cm dolgo iglo; pri nogah so menda ležale drobne koščice (jelenje) ter raznobarvne steklene jagode, bel ploščat kamen, dve majhni fibuli in 11 cm dolga igla, podobna tisti, ki jo je imela pokojnica na prsih. V zbirki Narodnega muzeja v Ljubljani pa je med najdbami brez ohranjenih grobnih celot ena igla s povešeno makovo glavico (sl. 74: 6).⁸⁰⁴

X/75 from the same tumulus, found together with a serpentine fibula, two bronze bracelets, two earrings, glass and amber beads as well as a bronze mace and a sun-shaped ring. As for Grave V/2 from Laščik, he noted six earrings (in other notes he mentioned only four), amber and glass beads, a Certosa fibula, a bracelet on each wrist and a pair of bracelets on the chest together with a 9cm long pin, while small bones (of a red deer), numerous multicoloured glass beads, white flat stone, two small fibulae and an 11cm long pin were found at the feet; the latter resembling the one on the chest. In addition to the pins cited above, the National Museum in Ljubljana keeps a poppy-headed pin without grave data (fig. 74: 6).⁸⁰⁴

Distribution and time frame. Pins with a biconical head and carved neck (fig. 74: 2) appear in the northern Adriatic area and in the Alps at the end of the Urnfield culture period.⁸⁰⁵ The find of such a pin at Magdalenska gora represents the earliest phase of settlement. The same

⁸⁰⁴ Tecco Hvala/Dular/Kocuvan 2004, T. 148: 12.

⁸⁰⁵ Müller-Karpe 1959, T. 56A: 2, 114A: 2, 193: 47,68; Gabovec 1973, 345 f; Carancini 1975, 227 f, 264, T. 52: 1652,1660, 57: 1891; Smolnik 1994, 102 f, T. 8: 1, 57: 10.

⁸⁰⁴ Tecco Hvala/Dular/Kocuvan 2004, T. 148: 12.

Razširjenost in časovni okvir. Igle z bikonično glavico in narezanim vratom (sl. 74: 2) se na severnojadranskem prostoru in v Alpah pojavljajo ob koncu kulture žarnih grobišč.⁸⁰⁵ Taka igla na Magdalenski gori predstavlja sled najzgodnejše faze poselitve, enako velja za igli z drobno vazasto glavico (sl. 74: 8, 9), ki jih prav tako srečamo že v žarnogrobiščnih nekropolah v Dobovi in Ljubljani.⁸⁰⁶

V žarnih grobiščih se pojavljajo tudi igle z zankasto uvito glavico (sl. 74: 3),⁸⁰⁷ vendar so sorodni primerki na Magdalenski gori izpričani v ženskih in dekliških opravih iz pozne kačaste in zgodnejše certoške stopnje (sl. 74: 4). Razgled po drugih najdiščih dolenske železnodobne skupnosti potrjuje njihovo uporabo v mladohalštatski ženski noši.⁸⁰⁸ Na drugi strani so zelo pogoste v grobovih svetolucijske skupnosti, kjer največkrat nastopajo kot edini nakit, toda zasledimo jih tudi v kombinacijah s fibulo očalarko brez osmice, dvozankasto fibulo, fibulo z oblogo, s čolničasto, trortasto, kačasto in certoško fibulo vrste V.⁸⁰⁹ Na Notranjskem pa so poleg bronastih primerkov⁸¹⁰ znane tudi v železni izvedbi.⁸¹¹

Večglave igle s trombastim zaključkom (sl. 74: 1) so bile razširjene na prostranem območju, ki sega od Padske nižine do severnega Podonavja in zahodne Panonije, z veliko koncentracijo na treh območjih – v Poadižju, Posočju in v Hallstattu.⁸¹² Magdalenskogorski primerek ima najožje paralele na Mostu na Soči, v grobovih iz časa Sv. Lucija Ib in Ic1,⁸¹³ ter v estenskih grobiščih, kjer se pojavljajo v stopnjah Este IIIA in IIIB po Peroniju (= Este II-srednje in pozno po Freyu).⁸¹⁴

⁸⁰⁵ Müller-Karpe 1959, T. 56A: 2, 114A: 2, 193: 47,68; Gabrovec 1973, 345 s; Carancini 1975, 227 s, 264, T. 52: 1652,1660, 57: 1891; Smolnik 1994, 102 s, T. 8: 1, 57: 10.

⁸⁰⁶ Stare F. 1954b, T. 26: 2, 54: 7; id. 1975, T. 10: 12.

⁸⁰⁷ Črnomelj-Sadež: Dular J. 1979, T. 12: 9; Dobova: Stare F. 1975, T. 7: 9, 34: 1; Ljubljana: Stare F. 1954b, T. 14: 1, 16: 2, 50: 3, 55: 1; Puš 1971, T. 2: 3, 50: 3; id. 1982, T. 21: 9, 53: 1,4; Novo mesto-Mestne njive: Knez 1984, T. 3: 15; Križ 1995, Kat. št. 84; Pobrežje: Pahič 1972, T. 7: 11, 16: 3; Ptuj-Hajdina: Müller-Karpe 1959, T. 116: 3; Tolmin: Svoljšak/Pogačnik 2001, T. 5: 1, 6: 2, 7: 3, 9: 4, 10: 1, 18: 4, 24: 1, 33: 2, 42: 2, 54: 1, 57: 7, 73: 5, 80: 4, 84: 6, 101: 4.

⁸⁰⁸ Brezje, gr. 7/4: Kromer 1959a, T. 25: 4; Dobrnič, gr. 13/5, 14/10, 18/7: Parzinger 1988–1989, T. 19: 7, 23: 3, 33: 8; Preska-Kosmatec, gr. 2: Guštin 1974b, T. 13: 8.

⁸⁰⁹ Gr. 15, 29, 229, 549, 1193, 1188, 1265, 1553, 2388-2: Teržan/Lo Schiavo/Trampuž-Orel 1984, T. 3B: 2, 5D: 3, 21C: 1, 47B: 4, 116E: 5, 117B: 2, 122B: 2, 144: 4, 255C: 2.

⁸¹⁰ Urleb 1974, T. 7: 14, 9: 2, 30: 11; Guštin 1979, T. 44: 21, 59: 3-8.

⁸¹¹ Guštin 1979, T. 39: 14,16, 44: 9,16, 59: 9,13-15.

⁸¹² Gabrovec 1968, 169 s, karta 1; Lunz 1974, 130, Taf. 81A; Frey 1980d, 74, Fig. 3.

⁸¹³ Npr. gr. 312, 944, 946, 679: Teržan/Lo Schiavo/Trampuž-Orel 1984, T. 29A: 1, 64G: 4, 95E: 1, 95F: 1.

⁸¹⁴ Npr. Casa di Ricovero, gr. 145, 155, 160, 234: Chieco Bianchi/Calzavara Capuis 1985, T. 25: 4, 59: 14 (M. = 1: 3!), 74: 16, 188: 3; Villa Benvenuti, gr. 61, 65, 77, 278, 280; Calzavara Capuis/Chieco Bianchi 2006, T. 11: 8, 23: 17, 46: 18, 193: 20, 200: 3.

can be said of the two vase-headed pins (fig. 74: 8, 9), which were also found in the Urnfield culture cemeteries at Dobova and Ljubljana.⁸⁰⁶

Found in Urnfield culture cemeteries were also roll-headed pins (fig. 74: 3).⁸⁰⁷ However, the similar examples from Magdalenska gora were found in graves with women's or girls' costumes from the Late Serpentine or Early Certosa Fibulae phases (fig. 74: 4). Other sites of the Dolenska Iron Age community confirm their use in the Late Hallstatt female costumes.⁸⁰⁸ On the other hand, they are also a common find in the graves of the Sveta Lucija community, where they often represent the only piece of jewellery, though they can also appear together with spectacle fibulae without the central figure-of-eight, two-looped fibulae, with an overlaid bow, boat fibulae, with three knobs on the bow, serpentine and Type V Certosa fibulae.⁸⁰⁹ In Notranjska, the recovered roll-headed pins were made both of bronze⁸¹⁰ and iron.⁸¹¹

Multi-knobbed pins with a trumpet guard (fig. 74: 1) were used across a wide area, from the Po Plain to the northern Danube basin and western Pannonia, with concentrations in three regions – Alto Adige, the Soča Valley and at Hallstatt.⁸¹² The pin of this type from Magdalenska gora has the closest parallels at Most na Soči, in graves from the Sv. Lucija Ib and Ic1 phases,⁸¹³ as well as in the cemeteries at Este, where they appear in phases Este IIIA and IIIB after Peroni (= Este II Middle and Late after Frey).⁸¹⁴ Pointing towards Este is also a stud-decorated clay situla from Grave VI/3 at Magdalenska gora as well as the stone-cist burial. The

⁸⁰⁶ Stare F. 1954b, T. 26: 2, 54: 7; id. 1975, T. 10: 12.

⁸⁰⁷ Črnomelj-Sadež: Dular J. 1979, T. 12: 9; Dobova: Stare F. 1975, T. 7: 9, 34: 1; Ljubljana: Stare F. 1954b, T. 14: 1, 16: 2, 50: 3, 55: 1; Puš 1971, T. 2: 3, 50: 3; id. 1982, T. 21: 9, 53: 1,4; Novo mesto-Mestne njive: Knez 1984, T. 3: 15; Križ 1995, Cat. No. 84; Pobrežje: Pahič 1972, T. 7: 11, 16: 3; Ptuj-Hajdina: Müller-Karpe 1959, T. 116: 3; Tolmin: Svoljšak/Pogačnik 2001, T. 5: 1, 6: 2, 7: 3, 9: 4, 10: 1, 18: 4, 24: 1, 33: 2, 42: 2, 54: 1, 57: 7, 73: 5, 80: 4, 84: 6, 101: 4.

⁸⁰⁸ Brezje, Gr. 7/4: Kromer 1959a, T. 25: 4; Dobrnič, Gr. 13/5, 14/10, 18/7: Parzinger 1988–1989, T. 19: 7, 23: 3, 33: 8; Preska-Kosmatec, Gr. 2: Guštin 1974b, T. 13: 8.

⁸⁰⁹ Gr. 15, 29, 229, 549, 1193, 1188, 1265, 1553, 2388-2: Teržan/Lo Schiavo/Trampuž-Orel 1984, T. 3B: 2, 5D: 3, 21C: 1, 47B: 4, 116E: 5, 117B: 2, 122B: 2, 144: 4, 255C: 2.

⁸¹⁰ Urleb 1974, T. 7: 14, 9: 2, 30: 11; Guštin 1979, T. 44: 21, 59: 3-8.

⁸¹¹ Guštin 1979, T. 39: 14,16, 44: 9,16, 59: 9,13-15.

⁸¹² Gabrovec 1968, 169 f, Karte 1; Lunz 1974, 130, Taf. 81A; Frey 1980d, 74, Fig. 3.

⁸¹³ For example Gr. 312, 944, 946, 679: Teržan/Lo Schiavo/Trampuž-Orel 1984, T. 29A: 1, 64G: 4, 95E: 1, 95F: 1.

⁸¹⁴ For example Casa di Ricovero, Gr. 145, 155, 160, 234: Chieco Bianchi/Calzavara Capuis 1985, T. 25: 4, 59: 14 (Scale = 1: 3!), 74: 16, 188: 3; Villa Benvenuti, Gr. 61, 65, 77, 278, 280; Calzavara Capuis/Chieco Bianchi 2006, T. 11: 8, 23: 17, 46: 18, 193: 20, 200: 3.

V estenski kulturni prostor nas vodita tudi glinasta situla z žebličastim okrasom iz omenjenega groba VI/3 na Magdalenski gori ter sam način pokopa v kamnito skrinjo. Na Dolenjskem in v Beli krajini so najdišča večglavih igel s trombastim zaključkom sicer precej gosto posejana, vendar je njihov skupni seštevek v primerjavi z navedenimi središči precej pičel. Običajno nastopajo v prestižnih vojaških opravah iz stopenj Podzemelj 2 in Stična 1,⁸¹⁵ iz česar bi lahko zaključili, da so velike igle v dolenjski moški noši predstavljale predmet posebnega pomena. Glede na masivnost in dolžino, ki pogosto presega 30 cm, si je s praktičnega vidika težko predstavljati, da bi jih uporabljali za spenjanje oblačila, prej bi jih lahko razumeli kot nekakšno insignijo.

V dolenjski halštatski noši igle niso bile tako priljubljene kot npr. v svetolucijski skupnosti. Primerki z bikonično, vazasto in makovo glavico pričajo o poselitvi Magdalenske gore v času stopnje Ljubljana II.

Večglave igle s trombastim zaključkom spadajo med moške pridatke v starejšem halštatskem obdobju (Ha C). Pojavljajo se pretežno v grobovih najvišjega ranga, zato in tudi zaradi izjemne velikosti bi jih lahko razumeli kot statusni simbol oz. kot neke vrste žezlo dolenjskih poglavarjev.

Igle z zankasto uvito glavico se v žarnogrobiščnem času pripisuje moški noši, medtem ko so v mlajšem halštatskem obdobju (Ha D) take igle uporabljale ženske. Enako velja za primerke s kroglasto glavico, ki so jih nekatere pripadnice magdalenskogorske skupnosti nosile v času kačastih in certoških fibul, morda za pripenjanje naglavnega ogrinjala po vzoru zahodnohalštatske mode. Za primer take rabe so nazorne skice grobov iz Magdalenenberga pri Villingenu⁸¹⁶ in iz Hallstatta,⁸¹⁷ kjer so sodile k ženskim opravam iz časa Ha D, medtem ko na Dolenjskem niso bile zelo razširjene.

⁸¹⁵ *Brezje*, gr. 6/5: Kromer 1959a, T. 18: 2; *Budinjak*, gr. 139/6: Škoberne 1999, sl. 41: 2, T. 8: 1 (železni primerek); *Dobrníč*: Stare V. 1973b, T. 5: 12; *Dragatuš*: Spitzer 1973, T. 15: 3; Škvor Jernejčič 2011, T. 17: 8; *Loka pri Črnomlju*, gr. 5/2: Dular J. 1983, T. 11: 1; *Novo mesto-Kapiteljska njiva*, gr. 1/16: Knez 1993, T. 17: 1,2; *Podzemelj-Grm*, gr. 2/3 idr.: Barth 1969, 117s, T. 9: 5, 17: 13; Dular J. 1978, T. 15: 15,17,18,22; *Stična*, grob z oklepom idr.: Gabrovec et al. 2006, T. 137: 15, 175: 66,67; Wells 1981, Fig. 44a; *Velike Malence*: Stare V. 1960–1961, T. 10: 1.

⁸¹⁶ Spindler 1973, Abb. 7.

⁸¹⁷ Hodson 1990, Fig. 12, 19, Pl. 63: G376.

sites that yielded multi-knobbed pins with a trumpet guard in Dolenjska and Bela krajina are numerous, but the number of pins from them is scarce in comparison to the concentrations named above. They usually formed parts of the prestige warrior outfit from the Podzemelj 2 and Stična 1 phases,⁸¹⁵ which could point to these large pins representing objects of a particular significance within the male costume of Dolenjska. Considering their solid body and length that often exceeds 30cm, it is difficult to imagine them being used to fasten the clothing; they could much easier be understood as insignia.

The pin was not as popular in the Dolenjska Hallstatt costume as, for example, within the Sveta Lucija community. The pins with a biconical head as well as the vase- and poppy-headed pins indicate the settlement of Magdalenska gora in the Ljubljana II phase.

Multi-knobbed pins with a trumpet guard form part of male grave goods in the Early Hallstatt period (Ha C). They appear mostly in graves of the highest ranking individuals, which, together with their great length, could lead us to interpret them as status symbols or sort of maces of the chieftains of Dolenjska.

Roll-headed pins are attributed to the male costume of the Urnfield culture period, while they were worn by women during the Late Hallstatt period (Ha D). The same could be observed for the spherical-headed pins, which some female members of the Magdalenska gora community wore in the Serpentine and Certosa Fibulae phases, possibly to fasten a veil in the west Hallstatt fashion. Such use is well illustrated by sketches of graves from Magdalenenberg near Villingen⁸¹⁶ and from Hallstatt,⁸¹⁷ where they appeared in the female costume in Ha D, while they were not widespread in Dolenjska.

⁸¹⁵ *Brezje*, Gr. 6/5: Kromer 1959a, T. 18: 2; *Budinjak*, Gr. 139/6: Škoberne 1999, Fig. 41: 2, T. 8: 1 (iron example); *Dobrníč*: Stare V. 1973b, T. 5: 12; *Dragatuš*: Spitzer 1973, T. 15: 3; Škvor Jernejčič 2011, T. 17: 8; *Loka pri Črnomlju*, Gr. 5/2: Dular J. 1983, T. 11: 1; *Novo mesto-Kapiteljska njiva*, Gr. 1/16: Knez 1993, T. 17: 1,2; *Podzemelj-Grm*, Gr. 2/3 and other examples.: Barth 1969, 117s, T. 9: 5, 17: 13; Dular J. 1978, T. 15: 15,17,18,22; *Stična*, Grave with cuirass and other examples: Gabrovec et al. 2006, T. 137: 15, 175: 66,67; Wells 1981, Fig. 44a; *Velike Malence*: Stare V. 1960–1961, T. 10: 1.

⁸¹⁶ Spindler 1973, Abb. 7.

⁸¹⁷ Hodson 1990, Figs. 12, 19, Pl. 63: G376.

4.7 FIBULE

Pregled fibul z Magdalenske gore je oprt na dose-danje tipološko-kronološke študije, ki kažejo, da je ta zvrst predmetov zelo občutljiv kulturni in kronološki indikator. Navsezadnje je z njimi utemeljena periodizacija mlajšega halštatskega obdobja na Dolenjskem, kot jo je predlagala Teržanova; v tej kronološki shemi, ki je splošno sprejeta v slovenski arheologiji, je obdobje 6. in 5. st. pr. n. št. razdeljeno na stopnjo kačastih fibul in stopnjo certoških fibul.⁸¹⁸

4.7.1 ENOZANKASTE FIBULE

V Peabodyjevem muzeju sta med najdbami z Magdalenske gore evidentirani dve bronasti enozankasti fibuli z listastim lokom in ena z žičnatim lokom okroglega preseka, enako fibulo hrani v sklopu magdalenskogorskih grobnih celot tudi dunajski muzej (sl. 76).

ENOZANKASTE FIBULE Z ŽIČNATIM LOKOM

Gre za zelo preprosto izvedbo zaponk, narejenih iz bronaste žice, ki je polkrožno ukrivljena in zvita v zanko, kar omogoča prožnost igle; drugi konec je ploščato razkovan in upognjen v obliki črke J v ležišče za iglo.⁸¹⁹ Ena takšna fibula je bila po poročanju Brattine najdena na prsnem košu slabo ohranjenega okostja v grobu 13/134 s Prelog (sl. 76: a), ki je imelo še štiri ploščate, vzdolžno preluknjane jantarne jagode. V okviru te grobne celote so inventarizirani še saltaleoni, drobna modra steklena jagoda in bronasta gladka zapestnica, ki jih Brattina ne navaja (sl. 77). Primerek v Peabodyjevem muzeju (sl. 76: b) predstavlja dvojnico fibule iz groba 13/134, grobna celota pa ni znana. Podobne fibule so bile najdene še v Ljubljani v strugi Ljubljanice ter v okolici Velikega Vinjega vrha (Šmarjeta), s čimer je seznam tovrstnih zaponk na Dolenjskem bolj ali manj izčrpan.⁸²⁰

Najštevilnejše paralele zanje najdemo v Tolminu, kjer so enozankaste fibule zelo pogost pridatek v tamkajšnjih žganih grobovih. Tipološko jih je podrobneje razčlenila Pogačnikova; magdalenskogorski fibuli bi lahko uvrstili v njen tip **I 1b** glede na okrogel presek loka in peresovine ter polkrožno oblikovano nogo. V kronološkem orisu tolminskega grobišča Teržanova

⁸¹⁸ Teržan 1976, 383 ss, sl. 59; Gabrovec 1987, 55 ss; id. 1999, 184 s; Dular J. 2003, 99 ss, sl. 51.

⁸¹⁹ Hencken 1978, Fig. 364x; Tecco Hvala/Dular/Kocuvan 2004, 73, T. 111E: 6.

⁸²⁰ *Ljubljanica*: Stare F. 1954b, T. 71: 1; Šinkovec 1995, 121 s, T. 36: 259; ead. 1996, 147 s; *Veliki Vinji vrh (Šmarjeta)-Strmec*: na tej lokaciji se poleg latenskih grobišč omenja tudi zgodnjehalštatsko plano grobišče z žganimi pokopi in dvema skeletnima grobovoma: Dular A. 1991, 58 s, T. 63: 1.

4.7 FIBULAE

The overview of the fibulae from Magdalenska gora is based on the typo-chronological studies done so far, which reveal this kind of objects as a very sensitive cultural and chronological indicator. In fact, it forms the basis for the periodization of the Late Hallstatt period in Dolenjska as proposed by Teržan. According to her chronological scheme, the period of the sixth and fifth centuries BC is divided into the phases of the Serpentine and the Certosa fibulae, respectively.⁸¹⁸

4.7.1 SINGLE-LOOPED FIBULAE

Two bronze single-looped fibulae with a leaf bow and one with a wire bow of a round cross-section from Magdalenska gora are kept in the Peabody Museum. Another fibula of the latter type is kept in the museum in Vienna as part of a grave group in Vienna (fig. 76).

SINGLE-LOOPED FIBULAE WITH A WIRE BOW

This fibula type (*Einschleifige Bogenfibel*) is of a very simple design. It is made of bronze wire curved into a semi-circular bow and a spring coil, which proceeds to pin. The other end of the wire is flattened and bent into a J-shaped catch-plate for the pin.⁸¹⁹ One such fibula was, according to Brattina, found on the chest of a poorly preserved skeleton in Grave 13/134 at Preloge (fig. 76: a), which also had four flat, longitudinally perforated amber beads. Not reported but inventoried in the museum as goods of this grave are saltaleoni, a small blue glass bead and a plain bronze bracelet (fig. 77). A similar fibula is registered in the Peabody Museum (fig. 76: b), though its grave group is not known. Other examples of such a fibula type were found in Ljubljana, more precisely in the riverbed of the Ljubljanica, and near Veliki Vinji vrh (Šmarjeta), which complete the list of wire-bow fibulae in Dolenjska.⁸²⁰

The most numerous parallels can be found at Tolmin, where single-looped fibulae represent a very frequent find in cremation graves. These fibulae were studied in detail by Pogačnik, who also proposed their typological subdivision. The two fibulae from Magdalenska gora could be ascribed to her Type I 1b based on

⁸¹⁸ Teržan 1976, 383 ff, Abb. 59; Gabrovec 1987, 55 ff; id. 1999, 162 f; Dular J. 2003, 99 ff, Abb. 51.

⁸¹⁹ Hencken 1978, Fig. 364x; Tecco Hvala/Dular/Kocuvan 2004, 73, T. 111E: 6.

⁸²⁰ *The Ljubljanica*: Stare F. 1954b, T. 71: 1; Šinkovec 1995, 121 f, T. 36: 259; ead. 1996, 147 f; *Veliki Vinji vrh (Šmarjeta)-Strmec*: mentioned at this site are La Tène cemeteries and adjacent to it also a flat cemetery from the Early Hallstatt period with cremations and two inhumations: Dular A. 1991, 58 f, T. 63: 1.

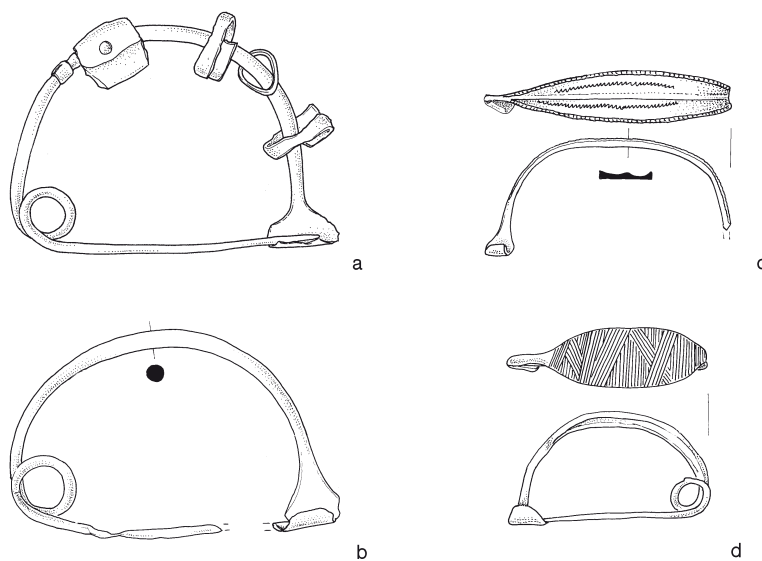

Sl. 76: Tipi enozankastih ločnih fibul z Magdalenske gore. M. = 1:2.

Fig. 76: Types of single-looped bow fibulae from Magdalenska gora. Scale = 1:2.

a – Preloge, gr. 13/134; b – najdba brez znane grobne celote v PM / find without preserved grave group in the PM;
c – Preloge, gr. VII/49; d – Tum. II.

predpostavlja, da se je ta varianta razvila iz starejše oblike z ožjo nogo (I 2a), ki je bila razširjena v osrednjem in južnem delu Apeninskega polotoka in na Siciliji ter vse tja do egejskega prostora, zastopana pa je tudi v dobovski žarnogrobiščni nekropoli, medtem ko naj bi različica I 1b predstavljala lokalni razvoj v času od konca 9. in v 8. st. pr. n. št. Teržanova jo postavlja na prehod iz stopnje Sv. Lucija Ia v Ib,⁸²¹ kar bi ustrezalo stopnji Podzemelj 1 na Dolenjskem.

V kraški regiji zasledimo take fibule v planem grobišču Brežec pri Škocjanu z žganimi pokopi, kjer nastopajo mestoma skupaj z enozankasto fibulo z listastim lokom.⁸²² Na Notranjskem se pojavljajo v šmihelskih grobiščih – v žganem grobu 76 v Mačkovcu in žarnem grobu 13 Pod Kaculjem, ki ju Guštin navaja kot tipična predstavnika stopnje Notranjska IIb.⁸²³ Poznala jih je tudi skupnost, ki je živela na Križni gori. Tam nastopa v žganem grobu 38, najdena pa je bila tudi v skeletnem grobu 101 na prsih pokojnice,⁸²⁴ ki predstavlja po načinu pokopa najboljšo analogijo za grob 13/134 z Magdalenske gore. V križnogorskih planih skeletnih grobovih iz časa stopnje Notranjska IIb srečamo enake jantarne jagode in saltaleone kot v magdalenskogorskem

the round cross-section of the bow and spring coil as well as the semi-circular foot. The chronological outline for the cemetery at Tolmin was written by Teržan, who supposed the variant to have developed from the earlier fibula form with a narrower foot (I 2a), which was spread from the central and southern Apennine Peninsula and Sicily to the Aegean, but was also present in the Dobova Urnfield culture cemetery. Having said that, Variant I 1b supposedly represented a locally developed form in use from the end of the ninth to the eighth century BC. Teržan dated the local variant to the transition from the Sv. Lucija Ia to Ib phases,⁸²¹ which would correspond to phase Podzemelj 1 in Dolenjska.

In the region of the Kras, such fibulae were evidenced in the flat cremation cemetery at Brežec near Škocjan, sometimes together with a single-looped fibula with a leaf bow.⁸²² The wire-bow fibulae were also found in Notranjska in the cemeteries of Šmihel, namely in cremation Grave 76 at Mačkovec and urn Grave 13 at Pod Kaculjem, both of which Guštin cites as the leading representatives of the Notranjska IIb phase.⁸²³ The fibulae were further known to the community living at Križna gora. In their cemetery, one such fibula was found in cremation Grave 38 and another one in inhu-

⁸²¹ Svoljšak/Pogačnik 2002, 27, sl. 7–11; Teržan 2002, 92 ss.

⁸²² Ruaro Loseri et al. 1977, Tav. IV/t. 49: 4, XIX/t. 209: 1, XX/t. 226: 2, XXV/t. 285: 1, XXXIII/t. 131: c, XXXIII/t. 165: m.

⁸²³ Guštin 1973, T. 4: 1, 5: 1; id. 1979, T. 39: 2, 49: 13.

⁸²⁴ Urleb 1974, T. 20: 17–19.

⁸²¹ Svoljšak/Pogačnik 2002, 27, Figs. 7–11; Teržan 2002, 92 ff.

⁸²² Ruaro Loseri et al. 1977, Tav. IV/t. 49: 4; XIX/t. 209: 1, XX/t. 226: 2, XXV/t. 285: 1, XXXIII/t. 131: c, XXXIII/t. 165: m.

⁸²³ Guštin 1973, T. 4: 1, 5: 1; id. 1979, T. 39: 2, 49: 13.

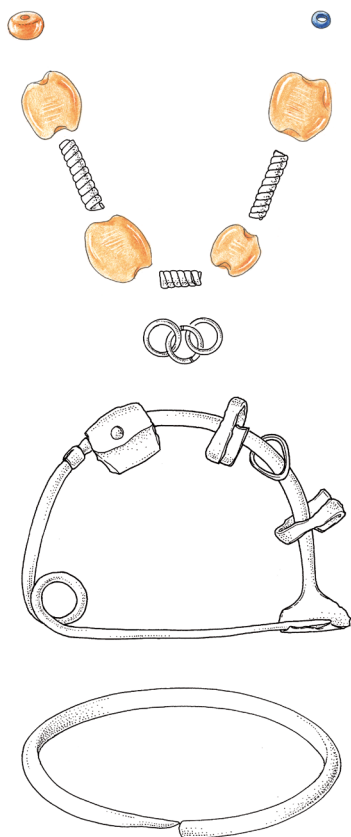

Sl. 77: Pridatki v skeletnem grobu 13/134 s Prelog na Magdalenski gori. M. = 1:2.

Fig. 77: Goods in inhumation Grave 13/134 at Preloge on Magdalenska gora. Scale = 1:2.

grobu 13/134,⁸²⁵ medtem ko v tolminskem grobišču in v Brežcu jantarja ni.

Glede na omenjene paralele bi lahko grob 13/134 postavili na začetek 8. st. pr. n. št., kar bi pomenilo, da imamo opravka z najstarejšim skeletnim pokopom na Magdalenski gori. Poglejmo si še njegovo lego v gomili in stratigrafski odnos do najbližjih grobov. Odkrit je bil na globini 3 m v JV predelu gomile. V tem delu gomile je bilo na globini 2,5 m zabeleženih precej žganih grobov, ki bi jim po žarah ter spremljajočih posodah lahko določili časovni razpon od stopnje Podzemelj 1 do Stične 1.⁸²⁶ Drugi grobovi v neposredni bližini so ležali višje v gomili, dva sta bila brez pridatkov (13/123, 13/133), druga dva (13/124, 13/127) pa po inventarju sodeč spadata v stopnjo certoških fibul.⁸²⁷

⁸²⁵ *Križna gora*, gr. 25, 72, 79, 112: Urleb 1974, T. 6: 7,8, 15: 20, 17: 2, 4, 22: 10,11; Guštin 1973, 470, sl. 2.

⁸²⁶ *Gr. 13/135, 13/141, 13/146, 13/147, 13/148*: glej tu poglavje 3.2.1 o žarnih pokopih, sl. 15.

⁸²⁷ Tecco Hvala/Dular/Kocuvan 2004, sl. 46, 49.

mation Grave 101, resting on the chest of a female.⁸²⁴ In burial rite, the latter serves as the best analogy for Grave 13/134 from Magdalenska gora. Moreover, the same amber beads and saltaleoni as in Grave 13/134 were found in inhumation graves of the Notranjska IIB phase at Križna gora,⁸²⁵ while there was no amber found at Tolmin and Brežec.

Considering the above-discussed parallels, Grave 13/134 could be set to the beginning of the eighth century BC, which would make it the earliest inhumation burial at Magdalenska gora. With that in mind, our attention turns to its position within the tumulus and its stratigraphic relationship to graves closest to it. The grave was found at a depth of 3m in the SE part of the tumulus. In that part, at a depth of 2.5m, a number of cremation graves were recorded dating from the Podzemelj 1 to Stična 1 phases on the basis of urns and accompanying vessels.⁸²⁶ Other graves in the immediate vicinity lay higher in the tumulus, two of them without goods (13/123, 13/133), while the goods in the other two (13/124, 13/127) set them into the Certosa phase.⁸²⁷

SINGLE-LOOPED FIBULAE WITH A LEAF BOW

The two fibulae of this type from Magdalenska gora are practically unique. One of them is published as part of Grave VII/49 from Preloge. It has a cast bow with three longitudinal ribs and tremolo decoration (fig. 76: c). Goldberg's notes reveal that the grave contained an inhumation and was dug into the earth below the tumulus. Reportedly found beside the skeleton were two poorly preserved bracelets, a black vessel, a bow fibula and a torque, though Goldberg did not provide a detailed description of these finds. Documented within this grave group at the Peabody Museum are one plain and one ribbed bronze bracelet as well as a knobbed torque, the latter similar to the one worn by the leading female representative of the Stična 2 phase buried in Grave VII/40 of the same tumulus.⁸²⁸ Considering the chequered history and disturbance of the Mecklenburg Collection, it is impossible to be sure that this fibula really was found in Grave VII/49. The best parallels for it can be found at Verruchio⁸²⁹ and in the Padova area.⁸³⁰ The second example of a leaf bow fibula at Magdalenska

⁸²⁴ Urleb 1974, T. 20: 17-19.

⁸²⁵ *Križna gora*, Gr. 25, 72, 79, 112: Urleb 1974, T. 6: 7,8, 15: 20, 17: 2, 4, 22: 10,11; Guštin 1973, 470, Fig. 2.

⁸²⁶ *Gr. 13/135, 13/141, 13/146, 13/147, 13/148*: see Chapter 3.2.1 on cremation burials, fig. 15.

⁸²⁷ Tecco Hvala/Dular/Kocuvan 2004, Abb. 46, 49.

⁸²⁸ Hencken 1978, 61, Fig. 270b, cf. figs. 261 and 262.

⁸²⁹ Gentili 2003, 355, T. CCCXXVI: 14.

⁸³⁰ *Prov. Padova*: Eles Masi 1986, 38, T. 16: 288.

ENOZANKASTE FIBULE Z LISTASTIM LOKOM

Izdelka z Magdalenske gore sta tako rekoč unikatna. En primerek je objavljen v sklopu groba VII/49 s Prelog in ima ulit lok s tremi vzdolžnimi rebri in tremoliranim okrasom (sl. 76: c). Iz Goldbergovih zapisov je moč razbrati, da je šlo za skeletni grob, ki je bil vkopan v mrtvico pod gomilo; okostje naj bi imelo dve slabo ohranjeni zapestnici, črno posodo, ločno fibulo in ovratnico, vendar predmetov podrobneje ni opisal. V Peabodyjevem muzeju so v sklopu te grobne celote evidentirane ena gladka in ena narebrena bronasta zapestnica ter vzlasta ovratnica, podobna tistim, ki jih je nosila vodilna predstavnica stopnje Stična 2, pokopana v grobu VII/40 v isti gomili.⁸²⁸ Zaradi kasnejšega dogajanja in posegov v Mecklenburško zbirko ne moremo biti trdno prepričani, da je enozankasta fibula z listastim lokom zares spadala med pridane tega groba, še najboljše paralele zanjo pa najdemo v Verucchiu⁸²⁹ in na območju Padove.⁸³⁰ Drug primerek fibule z listastim lokom z Magdalenske gore (sl. 76: d) je zabeležen med najdbami brez grobnih celot iz gomile II, ki je bila prav tako prekopana v okviru izkopavanja vojvodinje Mecklenburške.⁸³¹

Tovrstne fibule je Gabrovec označil za novost, ki se je v 8. st. pr. n. št. razširila s severnojadranskega in picenskega prostora.⁸³² Najstarejši italški primerki (iz Cumae in Bologne) segajo v 9. st., večina pa jih spada v zadnja desetletja 8. st. pr. n. št.⁸³³ Največ jih je znanih iz picenskega grobišča v Novilari, med katerimi ima ena lok okrašen z vtisnjenimi koncentričnimi krožci in pikami, druge pa so okrašene s snopi vrezov in šrafiranim cikcak okrasom. Beinhauer je prvo različico uvrstil v fazo Novilara Ib, drugo (številnejšo) pa v Iia, se pravi v čas druge in tretje četrtine 8. st. pr. n. št.⁸³⁴ Na območju zahodne in osrednje Slovenije sta znani obe različici, kjer jih zasledimo tudi v kombinacijah z drugačnimi fibulami (enozankasto z žičnatim lokom, polmesečasto fibulo, očalastimi fibulami z osmico ali brez osmice) ter z bronastim tordiranim torkvezom ali železnim obročastim nakitom, slednji je znanilec železne dobe na tem prostoru.⁸³⁵

⁸²⁸ Hencken 1978, 61, Fig. 270b, primerjaj s Fig. 261 in 262.

⁸²⁹ Gentili 2003, 355, T. CCCXXVI: 14.

⁸³⁰ *Prov. Padova*: Eles Masi 1986, 38, T. 16: 288.

⁸³¹ Hencken 1978, Fig. 31a.

⁸³² Gabrovec 1973, 348, 351 ss, T. 12.

⁸³³ Müller-Karpe 1959, 283; Guštin 1973, 469 ss, karta 2.

⁸³⁴ Beinhauer 1985, 544, T. 1: 11, 9: 134, 10: 136, 17: 263, 18: 269, 29: 434, 155: 1743, 176: 1971, 188: 2201.

⁸³⁵ *Križna gora, gr. 4*: Urleb 1974, T. 2: 3 (narisana kot zapestnica); Teržan 1987, Fig. 8: 5; *Ljubljana, gr. 144*: Puš 1971, T. 21: 13; Gabrovec 1973, T. 12: 1; *Most na Soči, gr. 2103*: Marchesetti 1893, T. 12: 4; *Škocjan-Brežec, gr. 49, 165, 259*: Ruaro Loseri et al. 1977, T. IV: 4, XXII: 13, XXXIII: r; Marchesetti 1981, T. XVI: 13; *Šmihel-Mačkovc, gr. 69*: Guštin 1973, T. 4: 9; id. 1979, T. 49: 1; *Tolmin, gr. 374, 387*: Svöljšak/Pogačnik 2001, T. 72: 2, 74: 2.

gora (fig. 76: d) is recorded among the isolated finds from Tumulus II, also excavated by the Duchess.⁸³¹

Gabrovec marked the fibulae of this type as a novelty that arrived in Dolenjska from the northern Adriatic and Picenum in the eighth century BC.⁸³² The earliest Italic examples (from Cumae and Bologna) date to the ninth century, though the bulk of the fibulae date to the last decades of the eighth century BC.⁸³³ Most were found in the Picene cemetery at Novilara, which include one fibula with impressed concentric circles and dots on the bow, while other fibulae bear stripes of incisions and hatched zigzag decoration. Beinhauer set the first variant to the Novilara Ib phase and the other, more numerous, to the Iia phase, that is the second and third quarters of the eighth century BC.⁸³⁴ Both variants are present in western and central Slovenia, where they were also found in combination with other types of fibulae (single-looped with a wire bow, semi-lunate, spectacle with or without the central figure-of-eight) as well as a bronze twisted torque or iron ring jewellery, the latter being the herald of the Iron Age in the area.⁸³⁵

4.7.2 TWO-LOOPED FIBULAE

Typological characteristics. Gabrovec published a discussion on two-looped fibulae (*Zweischleifige Bogenfibeln*) in 1970, which still represents the basic work on the subject. According to his typology, the two-looped fibulae from Magdalenska gora belong to Types **1a**, **5a**, **6a** and **6d**.⁸³⁶ The basic criteria of his typology are bow cross-section, form of the foot and metal used to make the fibula (iron, bronze or iron core with bronze coating). Group 1 consists of bronze examples with a plain bow of round cross-section and variously shaped feet. Of those, Type **1a** (fig. 78: 1) has either a triangular, semi-circular or low rectangular foot, bow and foot may be decorated, while the coil may either be single or double.⁸³⁷ The decorated examples of the bronze two-looped bow fibulae were studied in more detail by Teržan, who subdivided them into three variants: with transverse incisions on the entire

⁸³¹ Hencken 1978, Fig. 31a.

⁸³² Gabrovec 1973, 348, 351 ff, T. 12.

⁸³³ Müller-Karpe 1959, 283; Guštin 1973, 469 ff, Cart. 2.

⁸³⁴ Beinhauer 1985, 544, T. 1: 11, 9: 134, 10: 136, 17: 263, 18: 269, 29: 434, 155: 1743, 176: 1971, 188: 2201.

⁸³⁵ *Križna gora, Gr. 4*: Urleb 1974, T. 2: 3 (drawn as a bracelet); Teržan 1987, Fig. 8: 5; *Ljubljana, Gr. 144*: Puš 1971, T. 21: 13; Gabrovec 1973, T. 12: 1; *Most na Soči, Gr. 2103*: Marchesetti 1893, T. 12: 4; *Škocjan-Brežec, Gr. 49, 165, 259*: Ruaro Loseri et al. 1977, T. IV: 4, XXII: 13, XXXIII: r; Marchesetti 1981, T. XVI: 13; *Šmihel-Mačkovc, Gr. 69*: Guštin 1973, T. 4: 9; id. 1979, T. 49: 1; *Tolmin, Gr. 374, 387*: Svöljšak/Pogačnik 2001, T. 72: 2, 74: 2.

⁸³⁶ Gabrovec 1970, 11.

⁸³⁷ *Ibid.*, Karte IV.

4.7.2 DVOZANKASTE FIBULE

Tipološke značilnosti. Leta 1970 je izšla Gabrovčeva razprava o dvozankastih fibulah, ki še danes velja za temeljno študijo. Po njegovi tipološki razčlenitvi pripadajo dvozankaste fibule z Magdalenske gore tipom **1a**, **5a** ter **6a** in **6d**.⁸³⁶ Osnovni kriteriji za razločevanje tipov so mu bili: presek loka, oblika noge in kovina, iz katere so

surface of the bow, with stripes of incisions and with oblique incisions.⁸³⁸ Gabrovec, in his typology, did not consider the fibulae with a hollow bow as a special type. He mentioned them, though, when discussing the site of Dobrnič that yielded the greatest number of such fibulae. I have marked these fibulae as **Type 1v** (fig. 78: 2, 3). In their basic scheme, they correspond to Type 1a, but are larger, have a hollow bow as well as a lower

⁸³⁶ Gabrovec 1970, 11.

⁸³⁸ Teržan 1990a, map 8.

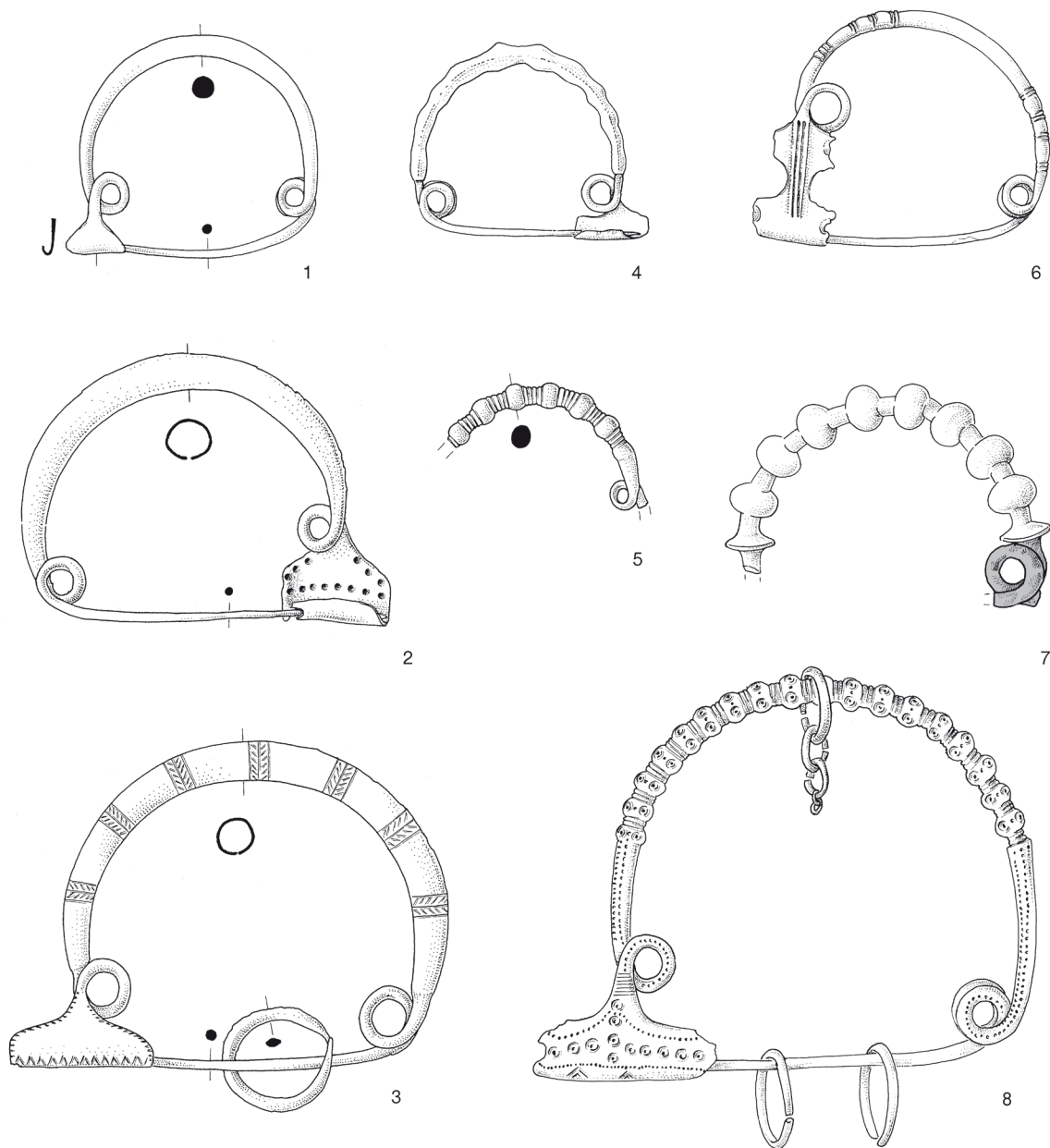

Sl. 78: Tipi dvozankastih ločnih fibul (po Gabrovcu) z Magdalenske gore. M. = 1:2.

Fig. 78: Types of two-looped bow fibulae (after Gabrovec) from Magdalenska gora. Scale = 1:2.

- 1 – najdba brez znane grobne celote v NHMW / find without preserved grave group in the NHMW (**1a**);
 2, 3 – najdbi brez znane grobne celote v NMS / finds without preserved grave group in the NMS (**1v**);
 4 – Preloge, gr. VII/32 (**6a**); 5 – najdba brez znane grobne celote v NMS / find without preserved grave group in the NMS (**6a**);
 6 – Preloge, Tum. VI (**8**); 7 – Preloge, gr. VI/24 (**5a**); 8 – Preloge, gr. VI/15 (**6d**).

bile izdelane (železo, bron ali železno jedro z bronasto oblogo). Fibule 1. vrste predstavljajo bronaste izdelke z gladkim lokom okroglega preseka in različno oblikovanimi nogami. Tip **1a** (sl. 78: 1) ima trikotno, polkrožno ali nizko pravokotno razširjeno nogo, lok in noga sta lahko ornamentirana, zanka pa je bodisi enojna ali dvojna.⁸³⁷ Ornamentirane primerke bronastih dvozankastih ločnih fibul je podrobneje razčlenila Teržanova in jih delila na različico s prečnimi vrezji po vsej površini loka ter različici s snopi vrezov ali s poševnimi vrezji.⁸³⁸ Fibul z votlim lokom Gabrovec ni obravnaval kot poseben tip, omenja jih pri najdišču Dobrnič, kjer je bilo najdenih največ takih primerkov; na tem mestu pa sem jim dala oznako **1v** (sl. 78: 2, 3). Po osnovni shemi namreč ustrezajo tipu 1a, le da so večje in imajo votel lok ter nižjo in bolj iztegnjeno nogo; večinoma so ornamentirane z vrezanim okrasom "jelkovih vejic" na loku, nekatere pa so brez okrasa.

Fibule vrst 5 in 6 imajo vozlast lok. Tip **5a** (sl. 78: 7), imenovan tudi tip Vače, združuje fibule z železnim jedrom in bronastim plaščem; tipično zanje je, da je na loku nanizanih osem vozlov.⁸³⁹ Tipa **6a** in **6d** (sl. 78: 4, 5, 8) predstavljata bronasto izvedbo, razlikujeta pa se po velikosti in po okrasu na loku.⁸⁴⁰

Precej drugačen je tip **8**, ki je prepoznaven po nogi v obliki peščene ure ter profiliranem loku na prehodu v peresovino in nogo, lok ima lahko mnogokoten, ovalen ali okrogel presek (sl. 78: 6).

Lega in kontekst. Konteksti dvozankastih fibul na Magdalenski gori so slabo poznani (sl. 79). Primerki iz zbirke ljubljanskega muzeja izvirajo iz zgodnejših kopanj Schulza in Pečnika na tem najdišču, med njimi lahko prepoznamo eno bronasto dvozankasto fibulo tipa **1a** brez ornamenta, tri primerke z votlim lokom, tri vaške fibule oz. tipa **5a**, eno bronasto vozlasto fibulo tipa **6a** ter eno tipa **6d**.⁸⁴¹ Slednjo je Gabrovec identificiral kot pridatek žarnega groba z vedrom tipa Kurd in čelado s figuralnim okrasom (Laščik, gr. 4/1), ki ga je izkopal Schulz pozimi 1881/82.⁸⁴² Na fibuli sta obešeni dve masivni bronasti zapestnici s snopi prečnih vrezov in "jelkovih vejic", k nakitu pa naj bi sodile še jantarne jagode, ki jih med predmeti ni mogoče zanesljivo določiti.

Na Laščiku je kopal tudi Pečnik leta 1892. Po pisanju Rutarja naj bi v grobu 1892/2 našel lok vozlaste fibule, dve bronasti zapestnici in železen prstan, na drugem mestu pa je zapisal, da so vanj spadale "kranjska fibula", zapestnice in igle. V grobu 1892/5 omenja "železno iglo za lase z bronastimi vozli" in tri posode, ki so bojda ležale sredi pepela in oglja. Na podlagi teh omemb je moč domnevati,

⁸³⁷ Ibid., karta IV.

⁸³⁸ Teržan 1990a, karta 8.

⁸³⁹ Gabrovec 1970, karta VIII; Grahek 2004, sl. 31; Teržan 2009a, Abb. 14: 7, 15.

⁸⁴⁰ Gabrovec 1970, karta IX; Teržan 1990a, karta 10.

⁸⁴¹ Tecco Hvala/Dular/Kocuvan 2004, T. 1: 2, 152: 1-4,9-12.

⁸⁴² Gabrovec 1964–1965b.

and more extended foot. They are mostly decorated with incised pine-sprig decoration on the bow, while some are undecorated.

Fibulae of Groups 5 and 6 have a knobbed bow. Type **5a** (fig. 78: 7), also named Type Vače, comprises fibulae with an iron core and bronze coating. It typically has eight knobs on the bow.⁸³⁹ Types **6a** and **6d** (fig. 78: 4, 5, 8) represent the bronze variant of Type Vače, further differing in size and bow decoration.⁸⁴⁰

Very different is Group **8**, which has an hourglass-shaped foot and mouldings on the bow at the transitions to the spring and to the foot. The bow is either polygonal, oval or round in cross-section (fig. 78: 6).

Position and context. The contexts of two-looped fibulae from Magdalenska gora are poorly documented (fig. 79). The examples of these fibulae from the collection of the museum in Ljubljana originate from the early excavations by Schulz and Pečnik. They include one bronze undecorated two-looped fibula of Type **1a**, three fibulae with a hollow bow, three Vače or **5a** type fibulae, one bronze knobbed fibula of Type **6a** and one of Type **6d**.⁸⁴¹ The latter was identified by Gabrovec as the good of the urn grave with the Kurd type bucket and the helmet with figural decoration (Laščik, Gr. 4/1), excavated by Schulz in the winter of 1881/82.⁸⁴² Threaded on the fibula are two solid bracelets decorated with stripes of transverse and pine-sprig incisions, while other pieces of jewellery in the grave include amber beads, which could not be positively identified among the objects kept in the museum.

According to Rutar, Pečnik unearthed a grave in 1892 at Laščik (1892/2) containing a knobbed fibula, two bronze bracelets and an iron finger-ring, while in another note Rutar wrote that the grave contained a "Carniolan" fibula, bracelets and pins. For Grave 1892/5, he mentions "an iron hair pin with bronze knobs" and three vessels that reportedly lay in the middle of ashes and charcoal. Based on these reports, we may identify these in the Type 5a fibulae typologically inventoried in the museum in Ljubljana.⁸⁴³

Several two-looped fibulae also form part of the Mecklenburg Collection.⁸⁴⁴ Two of Type **5a** are published as part of cremation Grave VI/24 from Preloge (fig. 78: 7), one with an iron bracelet attached to it. Urn Grave VI/27, from the same tumulus, revealed a Type **6a** fibula together with an iron ring. This type might further be ascribed the fibula from Grave VII/32 at Preloge (fig. 78: 4), which is made entirely of bronze and has barely

⁸³⁹ Gabrovec 1970, Karte VIII; Grahek 2004, fig. 31; Teržan 2009a, Abb. 14: 7, 15.

⁸⁴⁰ Gabrovec 1970, Karte IX; Teržan 1990a, map 10.

⁸⁴¹ Tecco Hvala/Dular/Kocuvan 2004, T. 1: 2, 152: 1-4,9-12.

⁸⁴² Gabrovec 1964–1965b.

⁸⁴³ Tecco Hvala/Dular/Kocuvan 2004, T. 152: 1-3.

⁸⁴⁴ Hencken 1978, 44–48, 56 f, Figs. 189e, 198a,b, 201b, 205b, 218b, 252a.

Gom. / gr. Tum. / gr.	Pokop / Burial rite	Spol / starost Sex / Age	Tipi fibul / Types of fibulae	Št. fibul / No. of fibulae	Ovratnice / Torques	Steklene jagode / Glass beads	Jantar / Amber	Zapestnice / Bracelets	Obročki / Rings	Čelada / Helmet	Lončenina / Pottery	Br onasto posodje / Bronze vessels
P VI/24	C	F	5a	2				2 Fe				
L 1892/2	?	F		1				2 br				
L 1892/5	C	F		1?							3	
P VI/27	C	F	6a	1		1		1 Fe	1		1	
P VII/32	C	F	6a?	1+1*							2	
P VI/15	C	I	6d	1	1	1 br			3		1	
L 4/1	C	F+M	6d	1			x	2 br		1		1
P VI/31	S?	F	1v	1			x					

Sl. 79: Struktura pridatkov v grobovih z dvozankastimi fibulami na Magdalenski gori. * = drugačen tip.
Fig. 79: Structure of goods in the graves with two-looped bow fibulae at Magdalenska gora. * = other type.

da gre za fibule tipa 5a, ki so v zbirki ljubljanskega muzeja inventarizirane po tipološkem principu.⁸⁴³

Nekaj dvozankastih fibul je prav tako v Mecklenburški zbirki.⁸⁴⁴ Dva primerka tipa 5a sta objavljena v sklopu žganega groba VI/24 s Prelog (sl. 78: 7), ene se drži še železna zapestnica. V žarnem grobu VI/27 iz iste gomile pa nastopa tip 6a skupaj z železnim obročastim nakitom. Morda bi k temu tipu lahko pripisali še primerk iz groba VII/32 s Prelog (sl. 78: 4), ki je v celoti bronast in ima rahlo nakazane vozle na loku. Goldberg je zapisal, da je grob vseboval eno manjšo posodo in veliko rdečkasto žaro, v kateri so bile sežgane kosti in dve fibuli, ki jih ni podrobneje opisal; drug primerk fibule, ki je objavljen v tem sklopu, spada med kačaste fibule z valovitim lokom. V gomili VI na Prelogah naj bi bila najdena dvozankasta fibula z okrašenim vozlastim lokom tipa 6d (sl. 78: 8) z obeski, in sicer v grobu VI/15 skupaj z bronasto žičnato ovratnico ter bronasto jagodo, medtem ko naj bi ostali pridatki, objavljeni v tem sestavu, pripadali grobu VI/11. V skeletnem grobu VI/31 pa je zabeležena dvozankasta fibula z votlim lokom (= tip 1v), v kombinaciji z jantarnimi jagodami. Tej gomili naj bi pripadal tudi primerk tipa 8 (sl. 78: 6), ki nima znane grobne celote. Skopi podatki o kontekstih nakazujejo, da se take fibule na Magdalenski gori navezujejo na žgane pokope na Laščiku in na Prelogah, kjer so omejene na gomilo VI. Skeletni je bil le grob VI/31, ki tako predstavlja izjemo. Običajno so se nosile posamično, včasih skupaj s parom železnih ali bronastih zapestnic, z jantarno ogrlico ali z bronasto gladko ovratnico.

⁸⁴³ Tecco Hvala/Dular/Kocuvan 2004, T. 152: 1-3.

⁸⁴⁴ Hencken 1978, 44-48, 56 s, Fig. 189e, 198a,b, 201b, 205b, 218b, 252a.

discernible knobs on the bow. Of the finds from this grave, Goldberg noted a small vessel and a large urn that contained cremated bones and two fibulae, without providing a detailed description of the latter. The other fibula published in this grave is a serpentine fibula with a wavy bow. Tumulus VI at Preloge supposedly revealed a two-looped fibula with a decorated knobbed bow of Type 6d (fig. 78: 8) and pendants. It was found in Grave VI/15 together with a bronze wire torque and a bronze bead, while the rest of the objects published within this group were supposedly found in Grave VI/11. Documented in inhumation Grave VI/31 was a two-looped fibula with a hollow bow (= Type 1v), in combination with amber beads. The latter tumulus further revealed an example of Group 8 (fig. 78: 6), without its grave group being known. As shown above, the data on the two-looped fibulae from Magdalenska gora is scarce. Nevertheless, it indicates that the fibulae were found in cremation graves at Laščik and Preloge, at the latter limited to Tumulus VI. The only inhumation with such a fibula was Grave VI/31. The data also shows that these fibulae were usually worn individually, sometimes together with a pair of iron or bronze bracelets, with an amber necklace or a plain bronze torque.

Distribution and time frame. Two-looped fibulae represent a phenomenon tied to the beginning of the Iron Age in the south-eastern Alps, in the middle and lower Danube basin and the central Balkans, as was shown already by Gabrovec and also Teržan after him.⁸⁴⁵ Gabrovec attributed the phenomenon to the

⁸⁴⁵ Gabrovec 1970, 41 f, Karten I-VIII; Teržan/Trampuž 1973, Fig. 2.1; Teržan 1990a, maps 7-10; ead. 2009a, Abb. 15.

Razširjenost in časovni okvir. Dvozankaste fibule predstavljajo fenomen, ki je povezan s pojavom železne dobe v jugovzhodnoalpskem svetu, v srednjem in spodnjem Podonavju ter centralnem Balkanu, kot sta pokazala Gabrovec in za njim Teržanova.⁸⁴⁵ Gabrovec ga je povezoval s t. i. trakokimerijskim sunkom, ki je domnevno sprožil premike žarnogrobišnega prebivalstva in selitve obrtnikov. Vendar pa se v geografski razširjenosti posamičnih oblikovnih različic jasno kažeeta njihov lokalni značaj in razvoj. Jugovzhodnoalpski prostor je izoblikoval svojske bronaste tipe 1a, 2a, 3a, 4a, 6a in 6d ter železne različice oz. bronaste z železnim jedrom (2c in 5a). Tudi tip 8, ki je razprostranjen od Peloponeza na jugu, Karpatskega bazena na vzhodu do jugovzhodnega obrobja Alp na severu, ni povsem uniformen.

Dvozankaste ločne fibule tipa **1a** imajo središče v jugovzhodnih Alpah; posamični okrašeni primerki so zašli na zahod na območje kulture Golasecca (S. Bernardino di Briona), na vzhod pa v srednje Podonavje.⁸⁴⁶ Teržanova je pokazala, da se različice z okrašenim lokom pojavljajo od Podravja do Posočja, medtem ko na Dolenjskem niso izpričane, z izjemo Mokronoga.

Pojav dvozankastih fibul tipa **1a** brez okrasa na loku nakazuje v dolenjsko-belokranjski regiji žarni grob 220 v planem grobišču na Mestnih njivah v Novem mestu, ki je vseboval preprosto dvozankasto fibulo s tankim žičnatim lokom okroglega preseka in trikotno nogo, ki močno spominja na enozankaste izvedbe. Grob je datiran v stopnjo Ljubljana IIB, v njem so bili še železna ovratnica in par uhanov iz spiralno zvite bronaste žice.⁸⁴⁷ V isti čas sodi žgani pokop v kamnito skrinjo iz gomile na Brezju, kjer prav tako nastopa v kombinaciji z železnim obročastim nakitom (ovratnico in zapestnicama).⁸⁴⁸ V Dobrniču jo zasledimo v skeletnem grobu 18/24 skupaj z železnim nožem, eno bronasto izvotljeno jagodo, dvema modrima steklenima jagodama ter eno jantarno jagodo.⁸⁴⁹ Največ primerkov lahko naštejemo na Vačah in v okolici Velikega Vinjega vrha (Šmarjeta), kjer jih zasledimo na lokaciji Strmec, koder se je širilo plano grobišče s pretežno žganimi pokopi z začetka halštatske dobe.⁸⁵⁰ V kontekstu planega žarnega grobišča so zabeležene tudi v Mokronogu in v

so-called Thraco-Cimmerian expansion, which supposedly triggered the movements of the Urnfield culture population and migrations of the craftsmen. However, the geographic distribution of certain formal variants clearly shows a local character and development. Types 1a, 2a, 3a, 4a, 6a and 6d are mainly limited to the south-eastern Alpine area, as are the iron variants or those of iron with a bronze coating (Types 2c and 5a). Even Group 8, the distribution of which extends from the Peloponnesus in the south, Carpathian basin in the east and the south-eastern fringes of the Alps in the north, is not entirely uniform.

Two-looped fibulae of Type **1a** have their centre in the south-eastern Alps. Individual examples with a decorated bow found their way westwards into the Golasecca culture area (S. Bernardino di Briona) and eastwards into the middle Danube basin.⁸⁴⁶ In her study, Teržan showed that the decorated variants appear from the Drava to the Soča basins and avoid Dolenjska, where there were only documented at Mokronog.

The presence of two-looped fibulae of Type **1a** without decoration on the bow in Dolenjska and Bela krajina is indicated by urn Grave 220 from the flat cemetery at Mestne njive, Novo mesto. This grave revealed a simple two-looped fibula with a thin wire bow of round cross-section and a triangular foot, which is strongly reminiscent of the single-looped variants. The grave further revealed an iron torque and a pair of earrings made of spiral bronze wire, dating the grave to the Ljubljana IIB phase.⁸⁴⁷ The same date could be ascribed to the cremation stone cist burial from Brezje, where such a fibula appeared in combination with iron ring jewellery (torque and two bracelets).⁸⁴⁸ Another example was found at Dobrnič, in inhumation Grave 18/24 together with an iron knife and bronze, blue glass and amber beads.⁸⁴⁹ Most examples, however, came to light at Vače and in the vicinity of Veliki Vinji vrh (Šmarjeta), the latter more precisely at Strmec, in a flat cemetery with predominantly cremation burials from the beginning of the Hallstatt period.⁸⁵⁰ Further fibulae within flat cremation cemeteries were found at Mokronog and Ljubljana. The two examples from Ljubljana, from Graves 181 and

⁸⁴⁵ Gabrovec 1970, 41 s, karta 1–8; Teržan/Trampuž 1973, sl. 2.1; Teržan 1990a, karte 7–10; ead. 2009a, Abb. 15.

⁸⁴⁶ Teržan/Trampuž 1973, 420 ss, pril. 1; Teržan 1990a, karta 8; Glunz 1997, Karte 4; Jablonka 2001, 112, Karte 3, T. 80: 1; *Mokronog*: Dular J. 2003, T. 9: 7 ter neobjavljena primerka, NMS inv. št. P 1598, P 1601.

⁸⁴⁷ Dular J. 2003, 102 s, sl. 56: 18. Ta tip fibule bi morda lahko prepoznali v bronastih fragmentih, ki so dokumentirani med sporadičnimi najdbami z Mestnih njiv v Novem mestu: Knez 1966, T. 4: 5.

⁸⁴⁸ *Gr. 14/1*: Kromer je grob označil s številko 82, ki naj bi ležal izven gomile 1: Kromer 1959a, 58, T. 14: 1; glej še Dular/Križ 1990, 543 s; Dular J. 2003, 109, sl. 59: 9.

⁸⁴⁹ Parzinger 1988–1989, T. 35: 6.

⁸⁵⁰ Stare V. 1973a, T. 53: 2; Dular A. 1991, 59, T. 61: 1,11, 63: 2, 68: 14,18.

⁸⁴⁶ Teržan/Trampuž 1973, 420 ff, Allegato 1; Teržan 1990a, map 8; Glunz 1997, Karte 4; Jablonka 2001, 112, Karte 3, T. 80: 1; *Mokronog*: Dular J. 2003, T. 9: 7 and unpublished examples, NMS Inv. Nos. P 1598, P 1601.

⁸⁴⁷ Dular J. 2003, 102 f, Abb. 56: 18. A fibula of this type may be identified in the bronze fragments documented among stray finds from Mestne njive in Novo mesto: Knez 1966, T. 4: 5.

⁸⁴⁸ *Gr. 14/1*: This grave is marked as No. 82 by Kromer, who also stated that it supposedly lay outside Tumulus 1: Kromer 1959a, 58, T. 14: 1; see also Dular/Križ 1990, 543 f; Dular J. 2003, 109, Abb. 59: 9.

⁸⁴⁹ Parzinger 1988–1989, T. 35: 6.

⁸⁵⁰ Stare V. 1973a, T. 53: 2; Dular A. 1991, 59, T. 61: 1,11, 63: 2, 68: 14,18.

Ljubljani. Ljubljanska primerka iz grobov 181 in 250 imata tanek žičnat lok, enako kot zaponka z Mestnih njiv v Novem mestu. Grob 181 je vseboval še iglo s stožčasto glavicco in poševno narezanim vratom, datiran pa je v stopnjo Ljubljana I Ib.⁸⁵¹ Podobni fibuli sta zabeleženi v grobu 285 ter na Kongresnem trgu v Ljubljani,⁸⁵² spominjata pa na svetolucijske primerke, za katere je značilen bolj odebeljen lok in dvojna peresovina na prehodu v iglo. V Posočju so bile zelo dolgo v uporabi, od stopnje Sv. Lucija Ib vse do I Ia,⁸⁵³ v kronološkem smislu pa je zgovorno dejstvo, da jih v tolminskem grobišču ni.⁸⁵⁴ V notranjsko-kraški regiji zasledimo dvozankasto fibulo s tankim žičnatim lokom v Tržišču in v Šmihelu pod Kaculjem, kjer je bila najdena v žganem grobu 33 iz časa stopnje Notranjska IIc po Guštinu (= stopnja Ljubljana IIIa oz. Podzemelj 2 na Dolenjskem).⁸⁵⁵

V Posočju, na Notranjskem in na Dolenjskem naletimo tudi na izpeljanke dvozankastih fibul, ki imajo votel lok, tj. različica I v (sl. 78: 2, 3). Dolenjski votli primerki so običajno precej veliki in imajo značilen okras vrezanih "jelkovih vejic". Največ jih je bilo odkritih v dobrniških gomilah, kjer se pojavljajo izključno v skeletnih grobovih, enako kot na Magdalenski gori (Preloge, gr. VI/31) in v Stični (gr. 5/13), medtem ko je bila v Homu pri Sajenicah najdena v žganem grobu pod gomilo.⁸⁵⁶ Podoben primerek je zabeležen še v Mengšu;⁸⁵⁷ enak okras "jelkovih vejic" na loku pa zasledimo tudi na fibuli iz grobišča v Ljubljani, le da je lok izdelan iz bronaste žice okroglega preseka, okoli katere je ulit bronast plašč.⁸⁵⁸ Ohranjene grobne celote kažejo, da so se zaponke z votlim lokom nosile posamično in le redko v kombinaciji z drugim nakitom. Edinole v dobrniškem grobu 12/7 jo srečamo skupaj z masivnima bronastima sklenjenima zapestnicama, v Stični pa skupaj z garnituro narebrenih nanožnic v poškodovanem grobu 5/13, ki bi ga lahko

⁸⁵¹ Puš 1971, T. 31: 6, 50: 8; Gabrovec 1973, 343, tabela 1.

⁸⁵² Stare F. 1954b, T. 68: 1; Puš 1982, T. 9: 9, 40: 3.

⁸⁵³ Teržan/Trampuž 1973, 420, pril. 1; *Most na Soči*, gr. 19, 58, 163, 267, 280, 445, 489, 480, 484, 637, 657, 715, 790, 879, 880, 948, 961, 1103, 1110, 1166, 1193, 1247, 1256, 1267, 1457, 1498, 1534, 1638, 1715, 1790 itd.: Teržan/Lo Schiavo/Trampuž-Orel 1984, 4B: 1, 8E: 1,2, 17F: 1, 26F: 3, 27G: 2, 37A: 1, 39C: 2, 40A: 2, 40B: 3,4, 56C: 1, 61C: 1, 69E: 2, 80A: 1, 88C: 1, 88E: 2,3, 97A: 1, 99D: 1, 110H: 1, 111A: 1, 115E: 1, 116E: 1, 120E: 2, 121D: 1, 123B: 1, 134A: 1, 143A: 1, 143E: 1, 153A: 4, 165C: 1, 171D: 2 itd.

⁸⁵⁴ Svoljšak/Pogačnik 2001.

⁸⁵⁵ Guštin 1973, 471 s, sl. 2: 15,18, T. 8: 3-6; id. 1979, T. 17: 12, 42: 1.

⁸⁵⁶ *Dobrnič*, gr. 12/6, 12/7, 12/8, 17/20, 18/15, 19/23; Parzinger 1988–1989, T. 17: 2,3,7, 32: 4, 34: 6, 39: 3; Stare V. 1973b, T. 6: 5; *Hom pri Sajenicah*, gr. 1/1: Dular J. 2003, T. 5: 1; *Mokronog*: neobjavljeno, NMS inv. št. P 1590; *Stična*, gr. 5/13 in posamične najdbe: Gabrovec et al. 2006, T. 118: 1, 148: 2, 165: 1, 172: 1, 185: 1; *Veliki Vinji vrh (Šmarjeta)*: Stare V. 1973a, T. 53: 1; Dular A. 1991, T. 68: 17.

⁸⁵⁷ Gabrovec 1965a, T. 3: 7.

⁸⁵⁸ Puš 1982, T. 40: 2.

250, have the same, thin wire bow, likewise the fibula from Mestne njive at Novo mesto. Besides the fibula, Grave 181 contained a conical-headed pin with an obliquely incised neck. The grave is dated to the Ljubljana I Ib phase.⁸⁵¹ Similar fibulae were documented in Grave 285 as well as at Kongresni trg in Ljubljana.⁸⁵² They are reminiscent of the Sveta Lucija examples, whereby the latter are characterized by a thicker bow and a double spring coil. Such fibulae enjoyed a long period of use in the Soča Valley, from the Sv. Lucija Ib to the I Ia phase.⁸⁵³ Chronologically telling is the absence of such fibulae in the cemetery at Tolmin.⁸⁵⁴ Two-looped fibulae with a thin wire bow were also found in the Notranjska-Kras region, more precisely at Tržišče and Šmihel-Pod Kaculjem. At the latter site, such a fibula was found in cremation Grave 33 dated to the Notranjska IIc phase after Guštin (= Ljubljana IIIa or Podzemelj 2 phase in Dolenjska).⁸⁵⁵

The Soča Valley, Notranjska and Dolenjska also revealed derivatives of two-looped fibulae with a hollow bow, of Type I v (fig. 78: 2, 3). The hollow-bow fibulae from Dolenjska are usually quite big and bear the characteristic incised pine-sprig decoration. Most were found in the tumuli at Dobrnič, in inhumation graves only. The same can be said of Magdalenska gora (Preloge, Gr. VI/31) and Stična (Gr. 5/13), while at Hom near Sajenice one such fibula was found in a cremation grave within a tumulus.⁸⁵⁶ Another similar example was documented at Mengeš.⁸⁵⁷ The same pine-sprig decoration also appears on the bow of a fibula from the Ljubljana cemetery, though its bow is made of bronze wire of round cross-section, around which a bronze coating is cast.⁸⁵⁸ The preserved grave groups show that the fibulae with a hollow bow were worn individually and only rarely in combination with other pieces of

⁸⁵¹ Puš 1971, T. 31: 6, 50: 8; Gabrovec 1973, 343, Tabelle 1.

⁸⁵² Stare F. 1954b, T. 68: 1; Puš 1982, T. 9: 9, 40: 3.

⁸⁵³ Teržan/Trampuž 1973, 420, Allegato 1; *Most na Soči*, Gr. 19, 58, 163, 267, 280, 445, 489, 480, 484, 637, 657, 715, 790, 879, 880, 948, 961, 1103, 1110, 1166, 1193, 1247, 1256, 1267, 1457, 1498, 1534, 1638, 1715, 1790 etc.: Teržan/Lo Schiavo/Trampuž-Orel 1984, 4B: 1, 8E: 1,2, 17F: 1, 26F: 3, 27G: 2, 37A: 1, 39C: 2, 40A: 2, 40B: 3,4, 56C: 1, 61C: 1, 69E: 2, 80A: 1, 88C: 1, 88E: 2,3, 97A: 1, 99D: 1, 110H: 1, 111A: 1, 115E: 1, 116E: 1, 120E: 2, 121D: 1, 123B: 1, 134A: 1, 143A: 1, 143E: 1, 153A: 4, 165C: 1, 171D: 2 etc.

⁸⁵⁴ Svoljšak/Pogačnik 2001.

⁸⁵⁵ Guštin 1973, 471 f, Fig. 2: 15,18, T. 8: 3-6; id. 1979, T. 17: 12, 42: 1.

⁸⁵⁶ *Dobrnič*, Gr. 12/6, 12/7, 12/8, 17/20, 18/15, 19/23; Parzinger 1988–1989, T. 17: 2,3,7, 32: 4, 34: 6, 39: 3; Stare V. 1973b, T. 6: 5; *Hom near Sajenice*, Gr. 1/1: Dular J. 2003, T. 5: 1; *Mokronog*: unpublished, NMS Inv. No. P 1590; *Stična*, Gr. 5/13 and finds without preserved contexts: Gabrovec et al. 2006, T. 118: 1, 148: 2, 165: 1, 172: 1, 185: 1; *Veliki Vinji vrh (Šmarjeta)*: Stare V. 1973a, T. 53: 1; Dular A. 1991, T. 68: 17.

⁸⁵⁷ Gabrovec 1965a, T. 3: 7.

⁸⁵⁸ Puš 1982, T. 40: 2.

datirali v stopnjo Stična 2 glede na to, da je bil enak komplet nanožnic najden v grobu 5/4 skupaj s kačasto fibulo s pestiči in dolgonožnima fibulama.⁸⁵⁹

Svetolucijske fibule z votlim lokom so drugačne (precej manjše od dolenjskih) in niso nikoli okrašene, zato bi v Posočju lahko predpostavljali drugo izdelovalno središče takih fibul v času stopnje Sv. Lucija Ic.⁸⁶⁰ Svetolucijsko različico najdemo še v notranjsko-kraški regiji – v grobišču Brežec pri Škocjanu in na Križni gori, kjer jih zasledimo tako v žganih kot v skeletnih grobovih. Guštin jih je časovno opredelil v stopnjo Notranjska IIIb (= stopnja Sv. Lucija Ic2 v Posočju ali stopnja Stična na Dolenjskem).⁸⁶¹

Če je genezo bronastih dvoankastih fibul tipa 1a in njihovih variant v Posočju, Ljubljani in na Dolenjskem moč razumeti kot izpeljavo iz enozankastega prototipa, pa tega ni mogoče trditi za vzhodne dežele, saj tam enozankastih fibul niso uporabljali.⁸⁶²

Idejne vzore za dvoankaste fibule z vzostim lokom tipov 5 in 6 je moč iskati na vzhodu – v zlatarskih izdelkih iz zakladne najdbe Mihačkow na ozemlju današnje Ukrajine in Fokoru v Panoniji ali pa v trakijskih fibulah s konca 9. oz. začetka 8. st. pr. n. št., kot sta pokazala Gabrovec in Teržanova.⁸⁶³ Tip 5a je predstavljal vodilno obliko dolenjske halštatske noše v stopnji Podzemelj oz. Ljubljana IIb/IIIa. Časovni razpon najbolje ponazarjajo grobovi v Novem mestu, kjer se tak tip fibule pojavlja že v okviru žarnega grobišča na Mestnih njivah (gr. 329), na drugi strani pa v skeletnem grobu 16/34 v gomili na Kapiteljski njivi, kjer nastopa skupaj s čolničasto fibulo.⁸⁶⁴ Slednji predstavlja najmlajši znani kontekst z dvoankasto fibulo tipa 5a. V planih grobiščih z žganimi pokopi jih zasledimo še na Bledu, v Ljubljani, na Molniku, verjetno tudi na Vačah ter v Sadežu pri Črnomlju. Pojavljajo pa se tudi v žganih grobovih pod gomilami (Magdalenska gora, Hrib pri Metliki) in v skeletnih gomilnih pokopih (Brezje, Dobrnič, Sajevece, Podzemelj, Loka pri Črnomlju in Pusti Gradac). Izven območja ljubljanske in dolenjske skupnosti sežejo le redki primerki.⁸⁶⁵

⁸⁵⁹ Gabrovec et al. 2006, T. 109–111.

⁸⁶⁰ Teržan/Trampuž 1973, pril. 1; *Most na Soči*, gr. 40, 299, 309, 384, 467, 518, 538, 591, 1132, 1485, 1492, 1697, 1731, 1946; Teržan/Lo Schiavo/Trampuž-Orel, T. 7A: 3, 27A: 4, 28C: 34G: 1, 40C: 1, 44A: 1, 45D: 1, 50E: 1, 112H: 1, 135A: 4, 136C: 1, 163E: 1, 166K: 1, 188D: 1. Dolenjskim izdelkom je podoben edinole primerek iz groba 2425 na Mostu na Soči, kjer nastopa v kombinaciji z vzlasto dvoankasto fibulo tipa 6a in velikima očalastima fibulama brez osmice: *ibid.*, T. 259A: 1.

⁸⁶¹ *Škocjan-Brežec*: Ruaro Loseri et al. 1977, Tav. II/11: 1, 21: 1, XXX/12: 1; *Križna gora*, gr. 49, 69, 95, 125: Urleb 1974, T. 11: 5, 15: 2, 19: 13, 25: 3, 30: 7; Guštin 1973, 473 s. sl. 2: 34.

⁸⁶² Gabrovec 1970, 36.

⁸⁶³ Gabrovec 1970, 40; Teržan/Trampuž 1973, 424 s. sl. 2.1; Teržan 1990a, karta 10; ead. 2009a, 202 ss, Abb. 12–15.

⁸⁶⁴ Križ et al. 2009, 114, 237, Kat. št. 4.4.3.

⁸⁶⁵ Gabrovec 1970, 27, 39, karta VIII; Grahek 2004, sl. 31; Teržan 2009a, Abb. 15.

jewellery. There are two exceptions to this; one is Grave 12/7 at Dobrnič, where it was found together with two solid annular bracelets, and the other damaged Grave 5/13 at Stična, where it was found with a set of ribbed anklets. The latter grave could be dated to the Stična 2 phase based on the same set of anklets found in Grave 5/4 together with a serpentine fibula with antennae and two long-footed fibulae.⁸⁵⁹

The Sveta Lucija fibulae with a hollow bow are different from those in Dolenjska; they are much smaller and never bear decoration. For that reason, we could suppose a separate production centre in the Soča Valley that was active in the Sv. Lucija Ic phase.⁸⁶⁰ The Sveta Lucija variant was also documented in the Notranjska-Kras region, more precisely in the cemetery at Brežec near Škocjan and at Križna gora. There, such fibulae appear in both cremation and inhumation graves. Guštin dates these graves to the Notranjska IIIb phase (= Sv. Lucija Ic2 in the Soča Valley and Stična phase in Dolenjska).⁸⁶¹

The two-looped fibulae of Type 1a and their variants in the Soča Valley, Ljubljana and Dolenjska may be understood as a derivation of the single-looped prototype. This, however, cannot hold true for the regions to the east, where single-looped fibulae were not in use.⁸⁶²

Models for the two-looped fibulae with a knobbed bow of Groups 5 and 6 may be sought in the east, in the gold products from the Mihačkow hoard in the present-day Ukraine and at Fokoru in Pannonia, but also in the Thracian fibulae from the end of the ninth or the beginning of the eighth century BC, as shown by Gabrovec and Teržan.⁸⁶³ Type 5a represents the leading form of the Dolenjska Hallstatt costume in the Podzemelj or Ljubljana IIb/IIIa phase. The time span of the type is best illustrated by the graves from Novo mesto, where such fibulae appear already in the urn cemetery at Mestne njive (Gr. 329), but also in inhumation Grave 16/34 in a tumulus at Kapiteljska njiva, in the latter together with a boat fibula.⁸⁶⁴ Grave 16/34 also represents the latest known context with a

⁸⁵⁹ Gabrovec et al. 2006, T. 109–111.

⁸⁶⁰ Teržan/Trampuž 1973, Allegato 1; *Most na Soči*, Gr. 40, 299, 309, 384, 467, 518, 538, 591, 1132, 1485, 1492, 1697, 1731, 1946; Teržan/Lo Schiavo/Trampuž-Orel, T. 7A: 3, 27A: 4, 28C: 34G: 1, 40C: 1, 44A: 1, 45D: 1, 50E: 1, 112H: 1, 135A: 4, 136C: 1, 163E: 1, 166K: 1, 188D: 1. Similar to the Dolenjska examples is a fibula from Grave 2425 at Most na Soči, found together with a two-looped knobbed fibula of Type 6a and two large spectacle fibulae without the central figure-of-eight: *Ibid.*, T. 259A: 1.

⁸⁶¹ *Škocjan-Brežec*: Ruaro Loseri et al. 1977, Tav. II/11: 1, 21: 1, XXX/12: 1; *Križna gora*, Gr. 49, 69, 95, 125: Urleb 1974, T. 11: 5, 15: 2, 19: 13, 25: 3, 30: 7; Guštin 1973, 473 f, Fig. 2: 34.

⁸⁶² Gabrovec 1970, 36.

⁸⁶³ Gabrovec 1970, 40; Teržan/Trampuž 1973, 424 f, Fig. 2.1; Teržan 1990a, map 10; ead. 2009a, 202 ff, Abb. 12–15.

⁸⁶⁴ Križ et al. 2009, 114, 237, Cat. Nos. 4.4.3.

Bronaste vozlaste fibule tipa **6a** so značilne predvsem za svetolucijsko nošo v stopnji Sv. Lucija Ic;⁸⁶⁶ zasledimo jih tudi v koroški⁸⁶⁷ in štajerski skupnosti, kjer so datirane v fazo Kleinklein I po Dobiatu (= Ljubljana IIB/IIIa oz. stopnja Podzemelj na Dolenjskem).⁸⁶⁸ V istem času so znane tudi v srednjem Podonavju na najdišču daljske železnodobne skupnosti v Sotinu pri Vukovarju.⁸⁶⁹ Teržanova daje primat v nastanku teh fibul štajerski skupnosti pred svetolucijskim kulturnim krogom. Za magdalenskogorski fibuli tipa **6d** domneva, da nista bili izdelani v svetolucijskem delavniškem krogu, primerja ju s štajerskimi z Rifnika, Griž-Šešč in Šentjanž ter s fibulo iz groba Benvenuti 126 v Este, kjer naj bi predstavljala tujek. To različico najdemo še na Vačah in v Podzemlju.⁸⁷⁰ Na teritoriju dolenske skupnosti so bronaste vozlaste fibule tipa 6a in 6d pogostejše na južnih najdiščih (Libna, Veliki Vinji vrh oz. Šmarjeta, Novo mesto, Podzemelj), kjer se pojavljajo v skeletnih grobovih v gomilah,⁸⁷¹ medtem ko so na Magdalenski gori izpričane v žganih gomilnih pokopih. Njihovo kronološko mesto v stopnji Stična je določeno z magdalenskogorskim grobom 4/1 z Laščika in grobom 2/17 s Kapitelske njive v Novem mestu.

V fibulah z nogo v obliki peščene ure (= tip **8** po Gabrovcu) se zrcali centralnobalkansko poreklo. Severno mejo je ta tip dosegel na Magdalenski gori, Vačah in v Kleinkleinu.⁸⁷² Na območju Dolenjske so znane predvsem v lokalni izvedbi, v večjem številu pa so zastopane na jugovzhodnih najdiščih (Libna, Veliki Vinji vrh oz. Šmarjeta).⁸⁷³ V dolenski izvedbi jo zasledimo še

⁸⁶⁶ Teržan/Trampuž 1973, 424 s, sl. 3, pril. 1; Teržan/Lo Schiavo/Trampuž-Orel 1984, T. 3D: 1, 5B: 1, 17C: 1, 17E: 4, 23E: 2, 28: 1, 36E: 3, 40A: 1, 45B: 1,60A: 1,2, 79C: 2, 100A: 1, 102H: 1, 122C: 2, 135B: 4, 138B: 1, 146B: 1, 147A: 1, 150D: 1, 150G, 152D: 1, 154A: 10,11, 157A: 5, 160D: 3, 175A: 1, 175D: 1, 175E: 2, 179A: 1, 179B: 1, 180A: 1, 182A: 1, 183A: 1, 183D: 1, 184A: 1, 185C: 1, 191B: 1, 194D: 1, 196B: 9, 198F: 1, 199A: 7, 199B: 1, 200C: 1, 202A: 1, 203B: 3, 204I: 1, 207: 1, 208B: 1, 210G: 1, 220F: 1, 221A: 1, 246A: 2, 259F: 1 itd.

⁸⁶⁷ Tomedi 2002, 173 ss, T. 1: 1, 91: 2, 116: 1,2.

⁸⁶⁸ Dobiat 1980, T. 6: 5, 10: 2, 17: 3, 58: 26, Beil. 4.

⁸⁶⁹ Ložnjak Dizdar 2010, 24 ss, 41, 43 ss, Kat. št. 8, 12.2.

⁸⁷⁰ Gabrovec 1970, 28 ss, karta IX: 6a; Teržan 1990a, 98 s, karta 10; Vače: neobjavljeno, NHMW inv. št. 6505; *Podzemelj*: Dular J. 1978, T. 1: 5. Najbolj severno najdišče je *Ettenhausen* pri *Schlechingu*: Glunz 1997, 168, Karte 5: Form C.

⁸⁷¹ *Libna*: Guštin 1976, T. 17: 1,2, 49: 7, 63: 16, 67: 2,3, 68: 1,2; *Novo mesto-Kapiteljska njiva*: Križ 1997, T. 12: 9; *Podzemelj*: Barth 1969, T. 14: 8, 17: 4; *Velike Malence*: Guštin 1996, Abb. 6: 8,9; *Veliki Vinji vrh (Šmarjeta)*: Stare V. 1973a, T. 19: 5, 53: 7,10, 60: 4; Dular A. 1991, T. 46: 10.

⁸⁷² Gabrovec 1970, 32, 37, 39, 42, karta XI; Dobiat 1980, T. 2: 4; Teržan 1990a, 139.

⁸⁷³ *Brezje, gr. 6/5*: Kromer 1959a, T. 18: 4; *Dobrnič, gr. 13/5, 18/6*: Parzinger 1988–1989, T. 19: 5, 33: 2; *Libna*: Guštin 1976, T. 13: 11, 58: 14,15, 59: 5,6, 63: 1,2,6, 67: 1,4, 68: 6–12; *Mokronog*: neobjavljeno, NMS inv. št. P 1598; *Novo mesto-Kapiteljska njiva, gom. 1* in *gr. 2/17*: Knez 1993, T. 37: 3; Križ 1997, T. 12: 3,9; *Podzemelj*: Dular J. 1978, T. 1: 9–11; *Rovišče*:

two-looped fibula of Type 5a. In flat cemeteries with cremation burials, such fibulae were found at Bled, Ljubljana, Molnik, probably also at Vače and Sadež near Črnomelj. In cremation burials under tumuli they appear at Magdalenska gora and Hrib near Metlika, while in inhumation burials under tumuli they were found at Brezje, Dobrnič, Sajevce, Podzemelj, Loka pri Črnomlju and Pusti Gradac. Only rare examples were found outside the territories of the Ljubljana and Dolenjska communities.⁸⁶⁵

Bronze knobbed fibulae of Type **6a** are characteristic primarily of the Sveta Lucija costume in the Sv. Lucija Ic phase;⁸⁶⁶ but they were also worn in the Carinthia / Koroška⁸⁶⁷ and Styria / Štajerska communities, where they are dated to the Kleinklein I phase after Dobiat (= Ljubljana IIB/IIIa or Podzemelj phase in Dolenjska).⁸⁶⁸ They are known in the same period in the middle Danube basin, for example at the site of the Dalj Iron Age community living at Sotin near Vukovar.⁸⁶⁹ In the conception of these fibulae, Teržan gives primacy to the Štajerska community over the Sveta Lucija cultural circle. She further supposes that the two Type **6d** fibulae from Magdalenska gora were not produced in the workshops of Sveta Lucija, and rather compares them to the examples from Štajerska, more precisely from Rifnik, Griže-Šešče and Šentjanž, but also to the fibula from Grave Benvenuti 126 at Este, whereby at the latter site such a fibulae represented a foreign object. The 6d variant fibulae were also found at Vače and Podzemelj.⁸⁷⁰ In the territory of the Dolenjska community, the bronze knobbed fibulae of Types 6a and 6d are more frequent at the southern sites (Libna, Veliki Vinji vrh (Šmarjeta), Novo mesto, Podzemelj), where they were found in inhumation graves under tumuli,⁸⁷¹ while at Magdalenska gora they were documented in cremation graves under

⁸⁶⁵ Gabrovec 1970, 27, 39, Karte VIII; Grahek 2004, fig. 31; Teržan 2009a, Abb. 15.

⁸⁶⁶ Teržan/Trampuž 1973, 424 f, Fig. 3, Allegato 1; Teržan/Lo Schiavo/Trampuž-Orel 1984, T. 3D: 1, 5B: 1, 17C: 1, 17E: 4, 23E: 2, 28: 1, 36E: 3, 40A: 1, 45B: 1,60A: 1,2, 79C: 2, 100A: 1, 102H: 1, 122C: 2, 135B: 4, 138B: 1, 146B: 1, 147A: 1, 150D: 1, 150G, 152D: 1, 154A: 10,11, 157A: 5, 160D: 3, 175A: 1, 175D: 1, 175E: 2, 179A: 1, 179B: 1, 180A: 1, 182A: 1, 183A: 1, 183D: 1, 184A: 1, 185C: 1, 191B: 1, 194D: 1, 196B: 9, 198F: 1, 199A: 7, 199B: 1, 200C: 1, 202A: 1, 203B: 3, 204I: 1, 207: 1, 208B: 1, 210G: 1, 220F: 1, 221A: 1, 246A: 2, 259F: 1 etc.

⁸⁶⁷ Tomedi 2002, 173 ff, T. 1: 1, 91: 2, 116: 1,2.

⁸⁶⁸ Dobiat 1980, T. 6: 5, 10: 2, 17: 3, 58: 26, Beil. 4.

⁸⁶⁹ Ložnjak Dizdar 2010, 24 ff, 41, 43 ff, Cat. Nos. 8, 12.2.

⁸⁷⁰ Gabrovec 1970, 28 ff, Karte IX: 6a; Teržan 1990a, 98 f, map 10; Vače: unpublished, NHMW Inv. No. 6505; *Podzemelj*: Dular J. 1978, T. 1: 5. The northernmost site is *Ettenhausen* near *Schleching*: Glunz 1997, 168, Karte 5: Form C.

⁸⁷¹ *Libna*: Guštin 1976, T. 17: 1,2, 49: 7, 63: 16, 67: 2,3, 68: 1,2; *Novo mesto-Kapiteljska njiva*: Križ 1997, T. 12: 9; *Podzemelj*: Barth 1969, T. 14: 8, 17: 4; *Velike Malence*: Guštin 1996, Abb. 6: 8,9; *Veliki Vinji vrh (Šmarjeta)*: Stare V. 1973a, T. 19: 5, 53: 7,10, 60: 4; Dular A. 1991, T. 46: 10.

na Notranjskem v žganem grobu 110 na Križni Gori.⁸⁷⁴ Za datacijo pa je na voljo bolj malo oprijemljivih kontekstov; na Brezju jo srečamo v žganem grobu s kamnito skrinjo (gr. 6/5) skupaj z večglavo iglo s trombastim zaključkom, ki je značilna za stopnjo Podzemelj 2.⁸⁷⁵ V Novem mestu je bila najdena v skeletnem grobu v gomili na Kapiteljski njivi (gr. 2/17) skupaj z dvozankasto vozlasto fibulo tipa 6a ter s trortasto in čolničasto fibulo, ki sta značilni za stopnjo Stična.⁸⁷⁶ Na te fibule spominja tudi primerek iz groba 11/15 v Dolenjskih Toplic, kjer nastopa v kombinaciji s certoško fibulo.⁸⁷⁷

Najstarejšo obliko zaponk na Magdalenski gori predstavljajo enozankaste fibule z žičnatim ali listastim lokom, ki imajo povezave na zahodu. Grob 13/134 s Prelog je hkrati tudi najstarejši skeletni grob na tem najdišču, najboljšo analogijo pa ima na Križni Gori na Notranjskem. Da enozankaste fibule stojijo razvojno pred dvozankastim tipom 1a, je najbolj očitno iz odnosa med posoškima nekropolama v Tolminu in na Mostu na Soči ter na Notranjskem. V osrednji Sloveniji in na Dolenjskem to razmerje ni tako jasno, saj se enozankaste fibule in dvozankasti tip 1a pojavljajo sočasno v t. i. železnem horizontu (*sl.* 80). Starejše primerke dvozankastih fibul s tankim žičnatim lokom in trikotno nogo, ki so skorajda na las podobni enozankastim izvedbam, zasledimo v planih grobiščih ter v žganih in skeletnih grobovih v gomilah iz časa stopnje Ljubljana IIB oz. Podzemelj 1. Hkrati pa se v fibulah tipa 1a po Gabrovcu že nakazujejo kulturne razlike in samosvoj razvoj različnih skupnosti, ki so naseljevale jugovzhodnoalpski prostor. Teržanova je pokazala, da so jim v štajerski, koroški in svetolucijski skupnosti sledile okrašene različice, ki jih dolenska skupnost ni uporabljala. Približno v istem času, tj. v stopnji Stična, je v osrednji Dolenjski vzniknila lokalna varianta z gladkim votlim lokom, ki se po velikosti in okrasu razlikuje od svetolucijskih primerkov, medtem ko na Štajerskem primerki z votlim lokom niso znani.

Te razlike med skupnostmi pridejo še bolj do izraza pri vozlastih fibulah. Vaška fibula (= tip 5a po Gabrovcu) je značilna predvsem za dolensko nošo v stopnji Podzemelj oz. Ljubljana IIB/IIIa (*sl.* 80), drugod pa predstavlja redkost. Vozlaste fibule tipa 6a in 6d so se

Stare V. 1962–1963, T. 5: 1; *Stična*: Gabrovec et al. 2006, T. 148: 1, 166: 1; Wells 1981, Fig. 118d, 173e; *Vače*: Stare F. 1955a, T. 21: 6 ter neobjavljena primerka, NHMW inv. št. 6509, 8470; *Velike Malence*: Stare V. 1960–1961, T. 8: 2,3, 9: 1–6; *Veliki Vinji vrh (Šmarjeta)*: Stare V. 1973a, T. 19: 1,2,4, 53: 3,6; 60: 1; Dular A. 1991, T. 68: 15,16.

⁸⁷⁴ *Križna gora*: Urleb 1974, T. 22: 1. En primerek je zastopan tudi v zbirki Battaglie, ki jo hrani univerza v Padovi: Borgna/Montagnari Kokelj 1999, 146, fig. 4: 2.

⁸⁷⁵ Kromer 1959a, T. 18: 4; glej še Dular/Križ 1990, 537.

⁸⁷⁶ Križ 1997, T. 12: 3.

⁸⁷⁷ Teržan 1976, T. 65: 12.

tumuli. They are dated to the Stična phase on the basis of Grave 4/1 from Laščik and Grave 2/17 from Kapiteljska njiva in Novo mesto.

The fibulae with an hourglass foot (Group 8 after Gabrovec) appear to be of a central Balkan origin. The type's northern border of appearance is traced by Magdalenska gora, Vače and Kleinklein.⁸⁷² In Dolenjska, they predominantly appear in a local variant, a more substantial number of which was documented at the south-eastern sites (Libna, Veliki Vinji vrh (Šmarjeta)).⁸⁷³ A Dolenjska variant fibula is evidenced in Notranjska, in cremation Grave 110 at Križna Gora.⁸⁷⁴ However, very few reliable contexts are available to propose a date. One of those is a cremation burial in a stone cist at Brezje (Gr. 6/5), where such a fibula was found together with a multi-knobbed pin with a trumpet-guard, characteristic of the Podzemelj 2 phase.⁸⁷⁵ At Novo mesto, another such fibula was found in an inhumation grave under a tumulus at Kapiteljska njiva (Gr. 2/17) together with a two-looped fibula with a knobbed bow of Type 6a, a three-knobbed and a boat fibula, the latter two characteristic of the Stična phase.⁸⁷⁶ Reminiscent of this fibula type is also an example from Grave 11/15 at Dolenjske Toplice, found in combination with a Certosa fibula.⁸⁷⁷

The earliest fibula form that appeared at Magdalenska gora is that of single-looped fibulae (*Einschleifige Bogenfibeln*) with either a wire or a leaf bow, which point to connections with the west. One such fibula was found in Grave 13/134 from Preloge, which is also the earliest inhumation burial at the site, with the best analogy at Križna Gora in Notranjska. In fibula development, the single-looped fibulae stand before the two-looped of Type 1a, which is evidenced by the relationship between

⁸⁷² Gabrovec 1970, 32, 37, 39, 42, Karte XI; Dobiat 1980, T. 2: 4; Teržan 1990a, 139.

⁸⁷³ *Brezje*, Gr. 6/5: Kromer 1959a, T. 18: 4; *Dobrnič*, Gr. 13/5, 18/6: Parzinger 1988–1989, T. 19: 5, 33; 2 *Libna*: Guštin 1976, T. 13: 11, 58: 14,15, 59: 5,6, 63: 1,2,6, 67: 1,4, 68: 6–12; *Mokronog*: unpublished, NMS Inv. No. P 1598; *Novo mesto-Kapiteljska njiva*, Tum. 1 and Gr. 2/17: Knez 1993, T. 37: 3; Križ 1997, T. 12: 3,9; *Podzemelj*: Dular J. 1978, T. 1: 9–11; *Rovišče*: Stare V. 1962–1963, T. 5: 1; *Stična*: Gabrovec et al. 2006, T. 148: 1, 166: 1; Wells 1981, Figs. 118d, 173e; *Vače*: Stare F. 1955a, T. 21: 6 and unpublished examples, NHMW Inv. Nos. 6509, 8470; *Velike Malence*: Stare V. 1960–1961, T. 8: 2,3, 9: 1–6; *Veliki Vinji vrh (Šmarjeta)*: Stare V. 1973a, T. 19: 1,2,4, 53: 3,6; 60: 1; Dular A. 1991, T. 68: 15,16.

⁸⁷⁴ *Križna gora*: Urleb 1974, T. 22: 1. One example is also kept in the Battaglia Collection at the University of Padova: Borgna/Montagnari Kokelj 1999, 146, fig. 4: 2.

⁸⁷⁵ Kromer 1959a, T. 18: 4; see also Dular/Križ 1990, 537.

⁸⁷⁶ Križ 1997, T. 12: 3.

⁸⁷⁷ Teržan 1976, T. 65: 12.

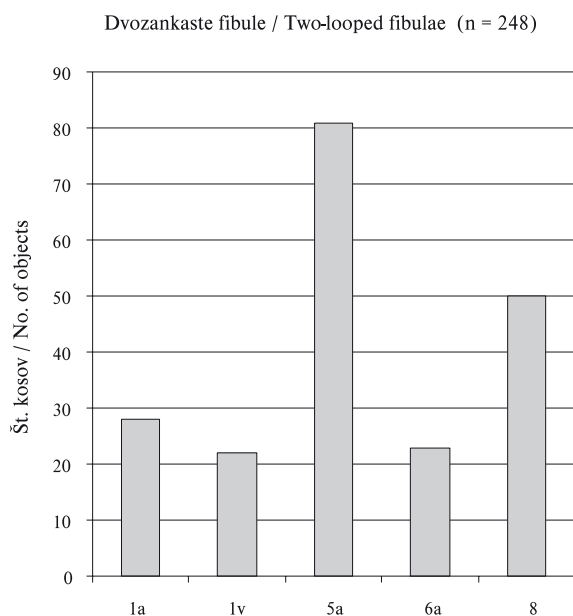

Sl. 80: Številčno razmerje in časovni razpon enozankastih (= tip I.1b po Pogačnikovi) in dvozankastih ločnih fibul (po Gabrovcu) v dolenjski skupnosti.

Fig. 80: Quantitative ratio and chronological span of single-looped (= Type I.1b after Pogačnik) and two-looped bow fibulae (after Gabrovce) in the Dolenjska community.

v štajerski skupnosti pojavile že na prehodu Ha B3/C1, v svetolucijski skupnosti so se razmahnille v stopnji Sv. Lucija Ic, istočasno so se pojavile tudi na Dolenjskem, tj. v stopnji Stična. Pogostejše so na jugovzhodnem koncu Dolenjske, kar je pomenljivo v smislu povezav s štajersko skupnostjo. Tudi fibule tipa 8 so na Dolenjskem najštevilneje zastopane na jugovzhodnih najdiščih, kjer jih zasledimo v stopnjah Podzemelj 2 do Stična 2.

Magdalenskogorska zbirka dvozankastih fibul kaže na odprtost te skupnosti za različne vplive in stike. V tipu 1a (sl. 78: 1) bi lahko prepoznali svetolucijski izdelek, žal pripadajoča grobna celota ni znana. V vaški vozlasti fibuli oz. tipu 5a (sl. 78: 7) se odraža ustvarjalni potencial lokalnih delavnic in dolenjska ženska noša, h kateri je spadal običajno še železen obročasti nakit. Lokalne izdelave je nemara tudi fibula tipa 8 (sl. 78: 6), čeprav je osnovna ideja centralnobalkanska. Nekatere pripadnice magdalenskogorskogorske skupnosti so v stopnji Stična nosile dvozankaste fibule tipov 6a, 6d in 1v. Prve (sl. 78: 4, 5, 8)

the two cemeteries from the Soča Valley, namely Tolmin and Most na Soči, on the one hand, and Notranjska, on the other. For central Slovenia and Dolenjska, this relationship is not so clear, since the single-looped and Type 1a two-looped fibulae appear contemporaneously in the so-called Iron Horizon (fig. 80). Earlier examples of two-looped fibulae (*Zweischleifige Bogenfibeln*), with a thin wire bow and a triangular foot, which are almost identical to the single-looped examples, were found in flat cemeteries as well as cremation and inhumation graves under tumuli of the Ljubljana IIB or Podzemelj 1 phase. At the same time, fibulae of Type 1a after Gabrovce already indicate cultural differences and an independent development of the various communities populating the south-eastern Alps. For the Styria / Štajerska, Carinthia / Koroška and Sveta Lucija communities, Teržan showed this type of fibulae to be succeeded by decorated variants, which were not in use in the Dolenjska community. At roughly the same time, i.e. the Stična phase, a local variant with a hollow bow appeared in central Dolenjska, which differed from the Sveta Lucija hollow-bow examples in size and decoration, while the region of Styria / Štajerska revealed no examples of this type.

Differences between communities become even more apparent when considering knobbed fibulae. The Vače fibula (= Type 5a after Gabrovce) is characteristic primarily of the Dolenjska costume in the Podzemelj or Ljubljana IIB/IIIa phase (fig. 80) and only rarely found elsewhere. Knobbed fibulae of Types 6a and 6d appeared in the Styria / Štajerska community already in the Ha B3/C1 transition, while in the Sveta Lucija community they became more numerous in the Sv. Lucija Ic phase, when they also appeared in Dolenjska (in the Stična phase). In Dolenjska, they are more frequent in the south-east, which is indicative in the sense of the connections with the Štajerska community. Fibulae of Group 8 are also represented most numerous at the south-eastern sites of Dolenjska, dating from the Podzemelj 2 to the Stična 2 phases.

The two-looped fibulae from Magdalenska gora show the community to have been open to various influences and contacts. Type 1a (fig. 78: 1), for example, could be seen as a Sveta Lucija product, even though the grave group of the fibula is not known. The Vače knobbed or Type 5a fibula (fig. 78: 7), on the other hand, reflects the creativity of the local workshops. It is a typical element of the Dolenjska female costume, which usually included iron ring jewellery. Possibly also locally produced were the fibulae of Group 8 (fig. 78: 6), though the basic idea behind their form came from the central Balkans. Some female members of the Magdalenska gora community wore two-looped fibulae of Types 6a, 6d and 1v in the Stična phase. The fibulae of Types 6a and 6d (fig. 78: 4, 5, 8) could conditionally be attributed to the Štajerska circle, though they ap-

bi pogojno lahko pripisali štajerskemu krogu, vendar jih v magdalenskogorskih grobovih srečamo skupaj z zahodnimi prviniami – tip 6a nastopa v kombinaciji s kačasto fibulo z valovitim lokom (Preloge, gr. VII/32), tip 6d pa skupaj s fragmentom čelade, okrašenem v orientalizirajočem stilu (Laščik, gr. 4/1). V dvoankastih fibulah z votlim lokom, ki sem jih označila za varianto 1v (sl. 78: 2, 3), pa bi lahko videli dolenski pendant svetolucijskim primerkom, le da so tamkajšnji izdelki manjši in neornamentirani.

4.7.3 ČOLNIČASTE FIBULE

Čolničaste fibule z območja današnje Slovenije je obdelala Barbara Jerin.⁸⁷⁸ Za tipološko opredelitev primerkov z Magdalenske gore uporabljam njeno nomenklaturu, čeprav so posamične oblikovne različice obravnavali tudi drugi avtorji.⁸⁷⁹

Tipološke značilnosti. Izdelane so bile po precej zahtevnem tehnološkem postopku. Ime so dobile po čolničasti obliki loka, ulitega okoli jedra, ki so ga po končanem postopku odstranili. Jerinova jih je razdelila na več skupin, te pa na več tipov. Primerke z Magdalenske gore je uvrstila v tipe 1a, 1b, 2b, 2d, 3 a–c in 6a, 6b.

Za tip **1a** je značilen visok polkrožen in bolj zaprt lok (sl. 81: 1, 6, 7), noga je približno enako dolga kot največji razpon loka in je zaključena s profiliranim gumbom, igla pa je lahko bronasta ali železna. Nekateri primerki so zelo veliki, vsi pa so ornamentirani s cikcak vrezi.⁸⁸⁰ Tip **1b** se razlikuje po okrasu na loku, ki je sestavljen iz snopov prečnih vrezov (sl. 81: 8).⁸⁸¹

Fibule tipa **2b**, ki so znane tudi kot šmarješki tip, so bolj gracilne in imajo nogo daljšo od razpona loka, ta je okrašen s tremi vzdolžnimi nazobčanimi rebri in svitkastimi odebelitvami na prehodu v iglo in nogo, ki se zaključuje z drobnim gumbkom (sl. 81: 10).⁸⁸² Fibule

⁸⁷⁸ Jerin 2001 (diplomsko delo). Avtorica pripravlja objavo v *Arheološkem vestniku*.

⁸⁷⁹ Müller-Karpe 1953; Stare F. 1954c; Stare V. 1976; Teržan 1990a, karte 12–16; Grahek 2004, sl. 32–35.

⁸⁸⁰ Tecco Hvala/Dular/Kocuvan 2004, T. 3A: 1, 133: 3, 152: 6.

⁸⁸¹ *Ibid.*, T. 152: 5.

⁸⁸² Hencken 1978, Fig. 5a,b, 226e, 274g,h, 283b; Tecco Hvala/Dular/Kocuvan 2004, T. 78D: 1, 133: 4.

pear in the graves of Magdalenska gora together with western elements – Type 6a with a serpentine fibula with a wavy bow (Preloge, Gr. VII/32) and Type 6d with a helmet fragment decorated in the Orientalising Style (Laščik, Gr. 4/1). The two-looped fibulae with a hollow bow, marked here as Type 1v (fig. 78: 2, 3), on the other hand, could be seen as a pendant to the Sveta Lucija examples, though the latter were smaller and undecorated.

4.7.3 BOAT FIBULAE

Boat fibulae (*Kahnfibeln*) from the territory of present-day Slovenia were collectively treated by Barbara Jerin.⁸⁷⁸ It is her nomenclature that I adopted in the discussion on the boat fibulae from Magdalenska gora, whereby I also cite the names for formal variants proposed by other authors.⁸⁷⁹

Typological characteristics. The boat fibulae were made following a rather demanding technological process. They were given its name by the boat-shaped bow cast around a core that was removed after the end of the casting process. Jerin divided them into several groups and subdivided into several types. The boat fibulae from Magdalenska gora belong to Types 1a, 1b, 2b, 2d, 3 a–c, 6a and 6b.

Type **1a** has a high semi-circular bow with a small opening on the lower side (fig. 81: 1, 6, 7). The foot is roughly as long as the maximum diameter of the bow and terminates in a moulded knob, while the pin is made either of bronze or of iron. Some examples are very big, others smaller, but all decorated with zigzag incisions.⁸⁸⁰ Type **1b** only differs in bow decoration, consisting rather of stripes of transverse incisions (fig. 81: 8).⁸⁸¹

Fibulae of Type **2b**, also known as Type Šmarjeta, are slenderer. Their foot is longer than the maximum bow diameter. The bow is decorated with three serrated longitudinal ribs and round mouldings at the pin-to-foot transition, while the foot terminates in a small knob (fig.

⁸⁷⁸ Jerin 2001 (graduate thesis to be published in *Arheološki vestnik*).

⁸⁷⁹ Müller-Karpe 1953; Stare F. 1954c; Stare V. 1976; Teržan 1990a, maps 12–16; Grahek 2004, Figs. 32–35.

⁸⁸⁰ Tecco Hvala/Dular/Kocuvan 2004, T. 3A: 1, 133: 3, 152: 6.

⁸⁸¹ *Ibid.*, T. 152: 5.

Sl. 81: Tipi čolničastih fibul (po Jerinovi) z Magdalenske gore. M. = 1:2.

Fig. 81: Types of boat fibulae (after Jerin) from Magdalenska gora. Scale = 1:2.

1 – Laščik, gr. 1882/1 (**1a**); 2 – Laščik, gr. 1892/13 (**3a**); 3 – Preloge, gr. X/72 (**3b**); 4 – Voselca, gr. 2/19 (**3c**); 5 – Preloge, gr. 2/8 (**6b**); 6 – Voselca, gr. 2/6 (**1a**); 7 – najdba brez znane grobne celote v NMS / find without preserved grave group in the NMS (**1a**);

8 – najdba brez znane grobne celote v NMS / find without preserved grave group in the NMS (**1b**);

9 – Preloge, Tum. VII (**2d**); 10 – Preloge, gr. VIII/9 (**2b**); 11 – Preloge, gr. 13/117 (**6a**); 12 – Preloge, Tum. 13 (**6b**).

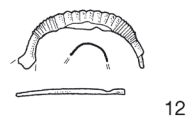
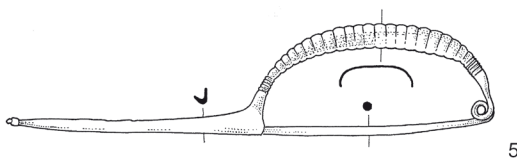
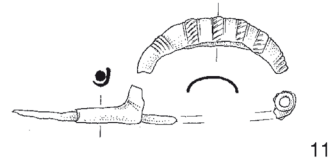
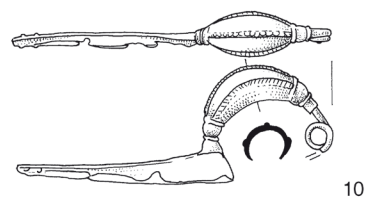
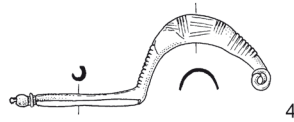
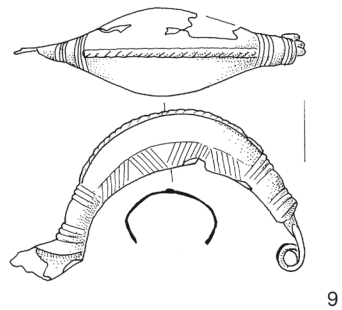
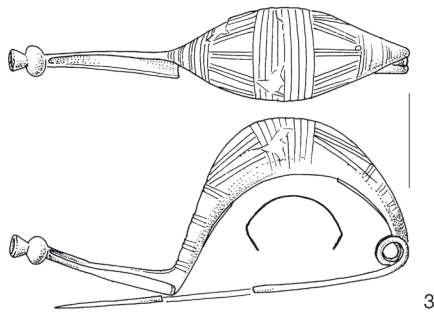
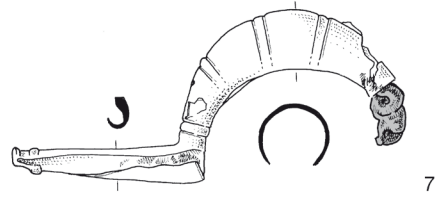
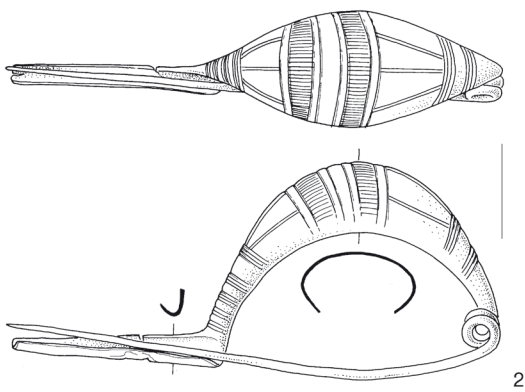
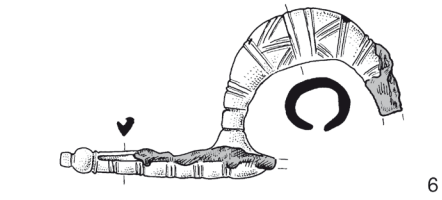
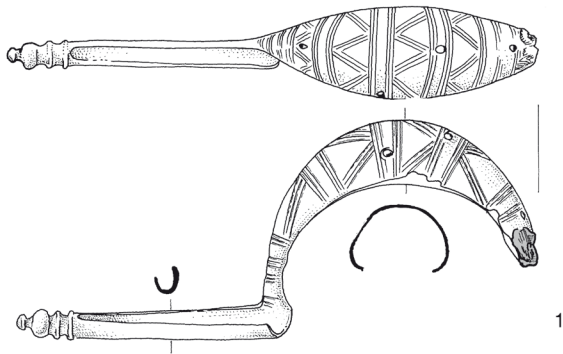

tipa **2d** imajo le eno vzdolžno rebro na sredini loka in vrezan okras ob straneh (sl. 81: 9).⁸⁸³

Z Magdalenske gore je znanih tudi nekaj primerkov 3. skupine po Jerinovi, za katere je značilen precej tanek in bolj širok lok, ki tekoče prehaja v iglo. Lok je okrašen s snopi prečnih vrezov, ki jih dopolnjujejo žarkasto razporejene vrezane linije. Tip **3a** predstavlja večje fibule z različnimi zaključki nog (sl. 81: 2),⁸⁸⁴ fibule tipa **3b** so nekoliko manjše in imajo na koncu noge značilen kroglast gumb s koničnim vdolbljenim čepkom (sl. 81: 3),⁸⁸⁵ tip **3c** pa označuje majhne fibule s precej odprtim lokom in z drobnim profiliranim gumbkom na koncu noge (sl. 81: 4).⁸⁸⁶

Preostali primerki čolničastih fibul z Magdalenske gore spadajo v 6. skupino po Jerinovi, za katero je značilen nizek oglat lok, ki je zelo odprt in sploščen, ležišče za iglo pa je upognjeno. Po ornamentu se delijo na dva tipa – tip **6a** ima lok okrašen s prečnimi mrežastimi pasovi (sl. 81: 11),⁸⁸⁷ tip **6b** pa ima narebreno površino loka (sl. 81: 5, 12).⁸⁸⁸

Lega in kontekst. Čolničaste fibule so bile na Magdalenski gori odkrite na Laščiku, Prelogah in Voselci. Zasledimo jih v žarnih pokopih, vendar so pogostejše v skeletnih grobovih (sl. 82). Fibula iz groba 13/101 na Prelogah je bila sežgana in je komajda razpoznavna, zato je ni mogoče podrobneje tipološko opredeliti. Ta grob je ležal 3 m globoko in bolj proti sredini gomile, označen je bil z veliko kamnito ploščo, pod katero je stal pitos lokalne izdelave, ob njem pa dva ciborija na visoki nogi, okrašena s plitvimi navpičnimi žlebiči in bradavicami na obodu. V žari so bili sežgani predmeti (fibula, široki trakasti vzdolžno nažlebljeni uhani in koščki bronaste situle), prekriti s tkanino, kar je bila estensko-svetolucijska navada. Drugi žarni grob s čolničasto fibulo je bil odkrit na Laščiku (1892/13), ki se s t. i. svetolucijskim pitosom prav tako navezuje na Posočje. Odkrili so ga pod velikansko kamnito ploščo, vanj so bili položeni ostanki kosti, ciborij in velika čolničasta fibula (tip **3a**), na kateri sta viseli dve bronasti masivni zapetnici (sl. 81: 2). Zelo podobna, le nekoliko manjša fibula (tip **3b**) je bila najdena v skeletnem grobu X/72 na Prelogah (sl. 81: 3), ki je ležal na vzhodnem robu gomile. Po Goldbergovih zabeležkah je imela pokojnica v tem grobu tudi eno kačasto fibulo, jantarno ogrlico ter masivne narebrene in votle zapetnice; pri njenih kolenih so bile najdene še debele jantarne jagode in v bližini koščki zlate folije. Hencken je objavil risbo tega groba, na kateri pa niso vidni vsi navedeni predmeti (sl. 37). Majhni fibuli tipa **3c** sta inventarizirani v sklopu groba 2/19 z Voselce (sl. 81: 4), vendar je grobna celota

81: 10).⁸⁸² Fibulae of Type **2d** differ in that they only have one longitudinal mid-rib on the bow and incised decoration at the sides (fig. 81: 9).⁸⁸³

Magdalenska gora boat fibulae also include several examples of Group 3 after Jerin. These have a rather thin but wide bow with a smooth transition into the pin. The bow is decorated with incised sheaf of rays and stripes of transverse incisions. Of Group 3, Type **3a** is represented by large fibulae with variously-shaped foot terminals (fig. 81: 2),⁸⁸⁴ Type **3b** is somewhat smaller and has a characteristic globular foot knob with a conical and indented protrusion (fig. 81: 3),⁸⁸⁵ while Type **3c** is represented by small fibulae with a rather large opening on the lower side of the bow and a small moulded knob at the end of the foot (fig. 81: 4).⁸⁸⁶

Magdalenska gora also revealed some examples of Group 6 after Jerin, characterised by a low angular, very open and flattened bow, as well as a curved catch. The group's subdivision is based on the decoration – Type **6a** has reticular decoration on its bow (fig. 81: 11),⁸⁸⁷ while the bow of Type **6b** is ribbed (fig. 81: 5, 12).⁸⁸⁸

Position and context. The Magdalenska gora boat fibulae were unearthed at Laščik, Preloge and Voselca in urn, but more frequently in inhumation graves (fig. 82). The boat fibula from urn Grave 13/101 at Preloge was burnt and cannot be determined as to its type. The grave lay at the depth of 3m and near the centre of the tumulus. It was marked with a large stone slab, under which a locally produced pithos was found, but also two bowls on a high foot and decorated with shallow vertical grooves and knobs on the shoulders. The urn contained burnt objects, namely the fibula, wide band earrings with longitudinal grooves and pieces of a bronze situla. The goods were covered with a cloth, which represents an Este-Sveta Lucija custom. The second urn grave with a boat fibula was found at Laščik (1892/13), which also shows ties with the Soča Valley through the so-called Sveta Lucija pithos found in it. The pithos was placed under a large stone slab and contained the bone remains, a footed bowl and a large boat fibula (Type **3a**) with two solid bronze bracelets threaded onto it (fig. 81: 2). A very similar, but smaller fibula (Type **3b**) was found in inhumation Grave X/72 at Preloge (fig. 81: 3), situated on the eastern edge of the tumulus. According to Goldberg, the female in the latter grave had, apart from the boat fibula, one serpentine fibula, an amber necklace as well as solid ribbed and hollow bracelets. Furthermore, large amber

⁸⁸² Hencken 1978, Figs. 5a,b, 226e, 274g,h, 283b; Tecco Hvala/Dular/Kocuvan 2004, T. 78D: 1, 133: 4.

⁸⁸³ Hencken 1978, Fig. 274c.

⁸⁸⁴ Tecco Hvala/Dular/Kocuvan 2004, T. 5A: 1.

⁸⁸⁵ Hencken 1978, Fig. 356.

⁸⁸⁶ Tecco Hvala/Dular/Kocuvan 2004, T. 138: 15,16.

⁸⁸⁷ *Ibid.*, T. 105: 28.

⁸⁸⁸ *Ibid.*, T. 17B: 1, 126: 5.

⁸⁸³ Hencken 1978, Fig. 274c.

⁸⁸⁴ Tecco Hvala/Dular/Kocuvan 2004, T. 5A: 1.

⁸⁸⁵ Hencken 1978, Fig. 356.

⁸⁸⁶ Tecco Hvala/Dular/Kocuvan 2004, T. 138: 15,16.

⁸⁸⁷ *Ibid.*, T. 105: 28.

⁸⁸⁸ *Ibid.*, T. 17B: 1, 126: 5.

Gom. / gr. Tum. / gr.	Pokop / Burial rite	Spol / starost Sex / Age	Tipi fibul / Types of fibulae	Št. fibul / No. of fibulae	Uhani / Earrings	Steklene jagode / Glass beads	Jantar / Amber	Zapestnice / Bracelets	Diadem / Diadem	Au nakit / Au jewellery	Scepter / Sceptre	Vijčki / Spindle whorls	Lončenina / Pottery	Bronasto posodje / Bronze vessels
L 1882/1	S	F	1a	1				15					1	
V 2/6	S	I	1a+2b	2+2*	2	br		6	x		x	1	3	
P 13/42	S	F	2b	1			x	2					1	
P VIII/9	?	F	2b	1		x		1						
L 1892/13	C	F	3a	1				2					2	
P X/72	S	F	3b	1+1*			x	5		x				
P 2/8	?	M?	6b	1				1 Pb						
P 13/101	C	F	?	1	3								3	1
P 13/143	S	F	?	1			x					1		

Sl. 82: Struktura pridatkov v grobovih s čolničastimi fibulami na Magdalenski gori. * = drugačen tip.

Fig. 82: Structure of goods in the graves with boat fibulae at Magdalenska gora. * = other type.

nezanesljiva, saj Pečnikovi poročili o grobnem inventarju nista skladni, razen tega se ne ujemata s stanjem v inventarni knjigi dunajskega muzeja.

Ob koncu zime leta 1882 so kmetje v peskokopu ob cesti na Laščiku naleteli na človeške kosti ter skupaj z njimi na veliko čolničasto fibulo tipa **1a** (sl. 81: 1) in množico preprostih bronastih obročev. Predmete je odkupil zbiratelj Sadnikar in jih naprej prodal dunajskemu muzeju, kjer so inventarizirani pod krajem Šmarje. S pomočjo Dežmanovega zapisa o tem odkritju smo lahko situacijo rekonstruirali in najdbe povezali v celoto, ki smo jo označili za grob 1882/1. Podobno manjšo fibulo (sl. 81: 6) je nosila tudi deklica ali mladenka, pokopana na Voselci v grobu 2/6 v bogati opravi, ki so jo sestavljali bronast diadem, bronaste jagode, štiri fibule (dve čolničasti, ena sanguisuga in ena dvortasta), par ozkih trakastih obsenčnikov ter šest majhnih zapestnic; razen tega so ji pridali še scepter, vijček in tri posode. Fragment čolničaste fibule tipa **1b** (sl. 81: 8) pa je v muzeju v Ljubljani med predmeti brez ohranjenih grobnih celot.

Pogostejše so t. i. šmarješke fibule oz. tip **2b** po Jerinovi (sl. 81: 10). Najdene so bile v gomilah I, VII, VIII in 13 na Prelogah ter v že omenjenem grobu 2/6 na Voselci. Med zanesljive kontekste lahko štejemo še grobna sestava 13/42 in VIII/9 s Prelog. Zabeležena je tudi v žarnem grobu VII/7 iz gomile na Prelogah, v katerem Goldberg omenja fibulo sanguisuga, ter v grobu I/2a, o katerem ni nobenih podatkov. Fibula tipa **2d** (sl. 81: 9) pa je inventarizirana v sklopu sporadičnih najdb iz gomile VII na Prelogah.

V dunajskem muzeju je med pridatki groba 13/117 s Prelog inventarizirana čolničasta fibula tipa **6a** (sl.

beads were found at her knees as well as pieces of gold foil in the vicinity. Hencken published a drawing of this grave, but it does not show all the above-listed objects (fig. 37). Two boat fibulae, of Type **3c**, are inventoried as part of Grave 2/19 from Voselca (fig. 81: 4). However, the reliability of this grave group is questionable due to inconsistent lists in the two Pečnik's reports, which do not correspond to the inventory book of the museum in Vienna that keeps the finds.

A large boat fibula of Type **1a** (fig. 81: 1) was unearthed by farmers working in a gravel pit along the road at Laščik at the end of the winter of 1882, together with human bones and a multitude of simple bronze rings. These objects were bought from the farmers by Sadnikar, who then sold them to the museum in Vienna, where they are inventoried under the site of Šmarje. We were able to reconstruct the grave group with the aid of Dežman's report on the find and tie the finds into a whole, marked as Grave 1882/1. A similar, but smaller fibula as in the latter grave was also worn by a girl or a young woman buried in Grave 2/6 at Voselca (fig. 81: 6). She had a rich costume, which consisted of a bronze diadem, bronze beads, four fibulae (two boat, one leech and one two-knobbed), a pair of flat wire temple-rings and six small bracelets. She was further buried with a sceptre, a spindle whorl and three vessels. A fragment of another boat fibula, of Type **1b** (fig. 81: 8), is kept in the museum in Ljubljana, among finds without known grave groups.

More frequent are the Šmarjeta fibulae or Type **2b** after Jerin (fig. 81: 10). They were found in Tumuli I, VII, VIII and 13 at Preloge and in the above-cited Grave 2/6

81: 11), vendar se število fibul in uhanov ne ujema s prvotnim virom. V grobu 2/8 s Preloge, ki je zelo skopo opisan, naj bi našli eno fibulo, ki se uvršča v tip **6b** (sl. 81: 5), ter svinčeno narokvico, ki je običajna za moško nošo v negovski stopnji. En manjši primerek take fibule nastopa tudi med posamičnimi najdbami iz gomile 13 na Prelogah (sl. 81: 12). Čolničasto fibulo omenja Brattina še v grobu 13/143 iz iste gomile, vendar je izgubljena, zato ni znano, kateri vrsti je pripadala; ležala naj bi na prsih pokojnice, ki je imela še jantarne jagode in vijček.

Na podlagi opisanih kontekstov bi lahko sklepali, da so take zaponke nosile ženske, v glavnem le po eno. Njihova lega na okostjih kaže, da so morda spenjale ogrinjalo na prsih. Fibule tipov 1a in 3b zasledimo v bogatejših ženskih oz. dekliških opravah s številnim obročastim okrasjem, medtem ko naj bi bil tip 6b najden domnevno v moškem grobu iz negovske stopnje (Preloge, gr. 2/8).

Razširjenost in časovni okvir. Na Dolenjskem in v Beli krajini so čolničaste fibule znanilke stopnje Stična. Najpogosteje je zastopan tip **1a** (sl. 83: A), kot je Jerinova označila velike čolničaste fibule s cikcak okrasom in jih kartirala.⁸⁸⁹ Njihovo razprostranjenost je prikazal tudi Tomedi, ki zanje uporablja oznako tip Este XIb. Ta tip je razširjen v južnih in vzhodnih Alpah in v Padski nižini, mnogo primerkov je znanih iz Este in z Mosta na Soči, manj pogoste so v koroški in štajerski skupnosti. Tomedi je posebej prikazal jugovzhodnoalpske derivate, ki jih je delil na varianti Podzemelj z levo in desno usmerjeno nogo ter varianto Šmihel.⁸⁹⁰ Na teritoriju dolenjske skupnosti se pojavljajo pretežno v skeletnih grobovih v gomilah,⁸⁹¹ zasledimo jih tudi v skeletnih planih grobovih,⁸⁹² v enem primeru pa celo v planem žarnem grobišču.⁸⁹³ Nosile so jih odrasle ženske in mladenke, velikokrat kot edini nakit ali pa v kombinaciji z drugimi čolničastimi tipi (1b, 2b, 6a), z rtastimi fibulami ter celo s kačasto in s t. i. proto-certoško fibulo. Te oprave so si precej podobne, sestavljajo jih ena ali dve fibuli, lahko tudi par obsenčnih obročkov

⁸⁸⁹ Jerin 2001, karta 1; Grahek 2004, sl. 35.

⁸⁹⁰ Tomedi 2002, 180 ss, Abb. 36 a,b.

⁸⁹¹ *Brezje*, gr. 1/34, 1/77, 2/2, 7/13, 7/34: Kromer 1959a, T. 6: 14, 15: 3, 16: 2, 27: 2, 32: 1; *Dobrnič*, gr. 4/3: Parzinger 1988–1989, T. 5: 2; *Dragatuš*, gom./gr. 40, 41, 45, 58: Spitzer 1973, T. 15: 9, 16: 4, 17: 7, 19: 15; Škvor Jernejčič 2011, T. 13: 3, 14: 1, 15: 15, 18: 3; *Gabrje*, gr. 1/2: Dular J. 2003, T. 4: 6; *Hom pri Sajenicah*, gr. 1/3: *ibid.*, T. 5: 4; *Kaplja vas-Lopanec*, gr. 2/1: *ibid.*, T. 84: 1; *Loka pri Črnomlju*, gr. 4/1: Dular J. 1983, T. 8: 1; *Podzemelj-Grm*, gr. 1/8, 1/16, 1/18, 3/4, 5/2, *Škrilje*, gr. 1/7, 2/14: Barth 1969, T. 12: 2, 15: 7, 16: 3, 21: 4, 23: 6, 31: 2, 36: 1; *Rovišče*, gr. 2-1884/3, 2-1884/6: Dular J. 2003, T. 74: 3,4; *Sajevce*, gr. 10/1: Guštin/Preložnik 2005, sl. 6: 1; *Veliki Vinji vrh (Šmarjeta)-Ivanec*, gr. 30/4: Guštin/Križ 2007, Fig. 6: 18.

⁸⁹² *Roje pri Trebelnem-Laze*, gr. 3, 8: Dular J. 2003, T. 27: 6,9; *Veliki Vinji vrh (Šmarjeta)-Strmec*, plano grobišče V, gr. 2: Dular A. 1991, T. 55: 6.

⁸⁹³ *Mokronog-Božji grob pri Slepšku*, gr. 17: Dular J. 2003, T. 6: 7.

at Voselca. Reliable contexts with such fibulae further include Graves 13/42 and VIII/9 from Preloge. One was also documented in urn Grave VII/7 from a tumulus at Preloge, in which Goldberg mentions a leech fibula, and another one in Grave I/2a, for which no other data is available. Also documented was a Type **2d** fibula (fig. 81: 9), which is inventoried among stray finds from Tumulus VII at Preloge.

A Type **6a** boat fibula (fig. 81: 11) is recorded in the inventory book of the museum in Vienna among the finds from Grave 13/117 from Preloge, but the number of fibulae and earrings does not correspond to the original source. Grave 2/8 from Preloge, which is very briefly described, supposedly revealed a Type **6b** fibula (fig. 81: 5), as well as a lead armband, which is the usual attribute of the male costume in the Negova phase. One smaller example of such a fibula also figures among stray finds from Tumulus 13 at Preloge (fig. 81: 12). A boat fibula is also mentioned by Brattina in Grave 13/143 from the same tumulus, supposedly found on the chest of the female who also had amber beads and a spindle whorl. This fibula is now lost and its type undeterminable.

The above-described contexts indicate that the boat fibulae formed part of the female costume and were mostly worn singly. Their position on the skeletons shows that they may have been used to fasten clothing on the chest. Fibulae of Types 1a and 3b formed part of rich female or girl costume that further included numerous pieces of ring jewellery, while Type 6b was supposedly found in a male burial from the Negova phase (Preloge, Gr. 2/8).

Distribution and time frame. In Dolenjska and Bela krajina, boat fibulae are heralds of the Stična phase. Most numerous represented is Type **1a** (fig. 83: A) or large boat fibulae with zigzag decoration, which Jerin classified and mapped.⁸⁸⁹ Their distribution was also studied by Tomedi, who marked them as Type Este XIb. Their distribution covers the area of the southern and eastern Alps as well as the Po Plain; numerous examples were further found at Este and Most na Soči, while they are less frequent in the communities of Carinthia / Koroška and Styria / Štajerska. Tomedi paid particular attention to the south-eastern Alpine derivatives, which he divided into two Podzemelj variants, with either a left- or a right-oriented foot, and the Šmihel variant.⁸⁹⁰ Boat fibulae appear on the territory of the Dolenjska community predominantly in inhumation burials under tumuli,⁸⁹¹

⁸⁸⁹ Jerin 2001, map 1; Grahek 2004, Fig. 35.

⁸⁹⁰ Tomedi 2002, 180 ff, Abb. 36 a,b.

⁸⁹¹ *Brezje*, Gr. 1/34, 1/77, 2/2, 7/13, 7/34: Kromer 1959a, T. 6: 14, 15: 3, 16: 2, 27: 2, 32: 1; *Dobrnič*, Gr. 4/3: Parzinger 1988–1989, T. 5: 2; *Dragatuš*, Tum./Gr. 40, 41, 45, 58: Spitzer 1973, T. 15: 9, 16: 4, 17: 7, 19: 15; Škvor Jernejčič 2011, T. 13: 3, 14: 1, 15: 15, 18: 3; *Gabrje*, Gr. 1/2: Dular J. 2003, T. 4: 6; *Hom near Sajenice*, Gr. 1/3: *ibid.*, T. 5: 4; *Kaplja vas-Lopanec*,

A

Najdišče Site	Tipi dvozankastih fibul (Gabrovec) Types of two-looped fibulae					Skupine čolničastih fibul (Jerin) Groups of boat-shaped fibulae				
	5a	6a 6d	1v	8	skupaj Total	1	2	3	6	skupaj Total
Veliki Vinji vrh (Šmarjeta)	8	5	2	8	23	28	39	1	5	73
Stična	11		5	4	20	2	31	7	2	42
Vače	21	1	2	3	27	6	10	2	8	26
Podzemelj	8	3		3	14	23	3			26
Mokronog	4	1	1	1	7	15	8		1	24
Magdalenska gora	5	4	4	1	14	4	9	3	3	19
Libna	2	8		16	26	5	8		3	16
Rovišče				1	1	12	1			13
Dobrnič	8		7	2	17	6	1			7
Dragatuš						5				5
Novo mesto	1	1		2	4	2		1		3
Metlika-Hrib	1				1	1	2			3
Črnomelj	5				5	2				2

B

Čolničaste fibule / Boat-shaped fibulae (n = 349)

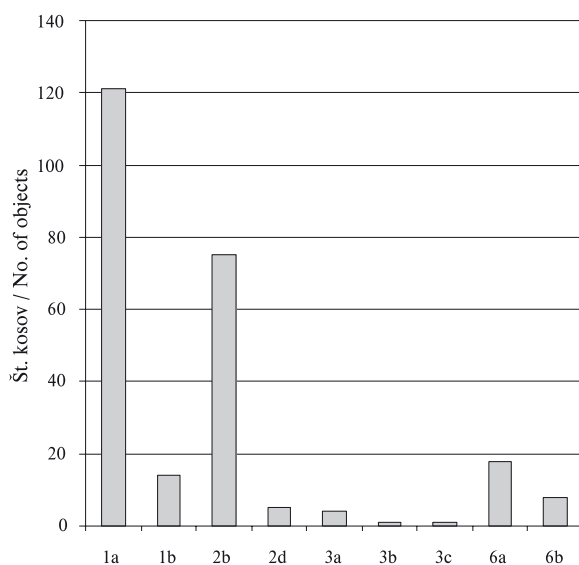

oz. uhanov, ena ali dve bronasti zapestnici, zraven je največkrat spadala še jantarna ogrlica, medtem ko jo skupaj z ovratnico redko zasledimo. Večja odstopanja je moč opaziti v nekaterih grobovih iz Podzemlja, ki so vsebovali železen nož ali železno tulasto sekuro in so morda predstavljali dvojne pokope.⁸⁹⁴ Obsedni obročki in uhani v teh sestavih so iz spiralno zvite okrogle ali ozke trakaste žice s presegajočimi konci. O železnem obročastem nakitu ni več sledi, razen v grobu 10/1 iz Sajevc, v katerem je bila najdena unikatna železna zapestnica, ki je bila na štirih mestih ovita s trakom iz bronaste pločevine.⁸⁹⁵ Običajno se povezujejo z bronastimi zapestnicami – spiralno zviti-

⁸⁹⁴ *Grm*, gr. 1/18, *Škrilje*, gr. 1/7, 2/14: Barth 1969, T. 16: 1-5, 31: 1-11, 36: 1,2.

⁸⁹⁵ Guštin/Preložnik 2005, 143, sl. 6: 3.

Sl. 83: A – Številčno razmerje med posameznimi tipi dvozankastih in čolničastih fibul v dolenski skupnosti.

B – Številčno razmerje med posameznimi tipi čolničastih fibul v dolenski skupnosti (po Jerinovi).

Fig. 83: A – Quantitative ratio of individual types of two-looped and boat fibulae in the Dolenjska community.

B – Quantitative ratio of individual types of boat fibulae in the Dolenjska community (after Jerin).

but they were also found in flat inhumation burials,⁸⁹² in one case even within a flat cremation cemetery.⁸⁹³ They were worn by women, young and old, often as the only piece of jewellery or in combination with other types of boat fibulae (1b, 2b, 6a), with two- or three-knobbed fibulae and even with a serpentine and a proto-Certosa fibula. The costume of these women was rather uniform and composed of one or two fibulae, possibly a pair of temple- or earrings, one or two bronze bracelets, most often an amber necklace and rarely a torque. A more noticeable deviation is discernible in several graves from Podzemelj, which contained an iron knife or an iron socketed axe and may have represented double burials.⁸⁹⁴ Temple-rings and earrings from the graves

gr. 2/1: *ibid.*, T. 84: 1; *Loka pri Črnomlju*, Gr. 4/1: Dular J. 1983, T. 8: 1; *Podzemelj-Grm*, Gr. 1/8, 1/16, 1/18, 3/4, 5/2, *Škrilje*, Gr. 1/7, 2/14: Barth 1969, T. 12: 2, 15: 7, 16: 3, 21: 4, 23: 6, 31: 2, 36: 1; *Rovišče*, Gr. 2-1884/3, 2-1884/ 6: Dular J. 2003, T. 74: 3,4; *Sajeve*, Gr. 10/1: Guštin/Preložnik 2005, Fig. 6: 1; *Veliki Vinji vrh (Šmarjeta)-Ivanec*, Gr. 30/4: Guštin/Križ 2007, Fig. 6: 18.

⁸⁹² *Roje pri Trebelnem-Laze*, Gr. 3, 8: Dular J. 2003, T. 27: 6,9; *Veliki Vinji vrh (Šmarjeta)-Strmec, flat cemetery V*, Gr. 2: Dular A. 1991, T. 55: 6.

⁸⁹³ *Mokronog-Božji grob near Slepšek*, Gr. 17: Dular J. 2003, T. 6: 7.

⁸⁹⁴ *Grm*, Gr. 1/18, *Škrilje*, Gr. 1/7, 2/14: Barth 1969, T. 16: 1-5, 31: 1-11, 36: 1,2.

mi, gladkimi in okrašenimi s snopi prečnih vrezov, pa tudi z narebrenimi in celo votlimi primerki. V opravah iz Dragatuša se pojavljajo še očalasti in antropomorfní obeski japonskega tipa, v enem primeru je bil pridan tudi apulski krater; predstavnici z Magdalenske gore in iz Sajevc pa sta imeli še diadem. Na Libni zasledimo čolničasto fibulo 1. skupine po Jerinovi skupaj z dvoankastimi fibulami tipa 8 po Gabrovcu ter s fragmentom kačaste fibule s krilci, parom bronastih zapestnic ter trikotnimi punciranimi obeski na verižicah.⁸⁹⁶ Čolničaste fibule tipa **1b** so omejene na teritorij dolenske skupnosti⁸⁹⁷ in se pojavljajo v podobnih kontekstih kot tip 1a, včasih celo skupaj.⁸⁹⁸

Drugo najpogostejšo obliko na tem prostoru predstavljajo čolničaste fibule 2. skupine po Jerinovi. Zasledimo jih v prostoru, ki sega od Dolenske do zahodne Panonije, segle so tudi severno od donavskega kolena, medtem ko so na zahod zašli le redki primerki.⁸⁹⁹ Jerinova jih je razdelila na šest tipov glede na število vzdolžnih reber na loku (2a–2f). Vsi ti tipi so na enem mestu zbrani samo v Hallstattu. Na Dolenskem je sicer predstavljen celoten spekter, toda ne na enem najdišču. Pet od šestih tipov je znanih edinole na Libni in v okolici Velikega Vinjega vrha (Šmarjete). Med njimi po količini in razprostranjenosti prednjači tip **2b** oz. t. i. šmarješki tip (*sl.* 83: B), ki je dobil ime po najdišču z največ primerki. Številni primerki tega tipa so bili najdeni tudi v Stični, medtem ko v Beli krajini nanje bolj redko naletimo. Tudi ta tip fibul se pojavlja izključno v skeletnih grobovih,⁹⁰⁰ srečamo jih v kombinacijah s čolničasto fibulo tipa 1a, s trortasto ali s kačasto fibulo, z jantarnimi in steklenimi ogrlicami, enkrat tudi z ovratnico. K tem opravam so pogosto spadale masivne bronaste zapestnice – gladke in okrašene s snopi vrezov ali narebrené, zasledimo pa tudi votle zapestnice in nanožnice. Najbogatejša konteksta predstavljata grobova z diademom z Magdalenske gore (Voselca, gr. 2/6) in iz Velikih Malenc.⁹⁰¹ Čolničaste fibule tipa **2d**, ki imajo eno sredinsko rebro ter vrezan okras pri strani loka, so na splošno bolj redke. Razen v Hallstattu so znane še z zahodnopanonskih najdišč ter v porečju Save od Kranja do Donje Doline.⁹⁰² Na teritoriju

⁸⁹⁶ Guštin 1976, 45, T. 63: 1-7.

⁸⁹⁷ Jerin 2001, karta 1; Grahek 2004, sl. 32.

⁸⁹⁸ *Dobrníč, gr. 7/8*: Parzinger 1988–1989, T. 9: 1; *Krajna Brda-Boršt, gom./skupek a*: Dular J. 2003, T. 52: 5; *Podzemelj-Grm, gr. 1/8*: Barth 1969, T. 12: 3; *Roje pri Trebelnem-Laze, gr. 1*: Dular J. 2003, T. 26: 7.

⁸⁹⁹ Teržan 1990a, karta 16; Glunz 1997, Karte 24; Jerin 2001, karta 2; Grahek 2004, sl. 33, 34.

⁹⁰⁰ *Brezje, gr. 1/34, 7/36, 13/22*: Kromer 1959a, T. 6: 7, 22: 6, 50: 5; *Čužnja vas-Osredek, gr. 2/3*: Dular J. 2003, T. 19: 12; *Dobrníč, gr. 1/9*: Parzinger 1988–1989, T. 2: 5; *Libna-Volavškova gom./gr. 6*: Guštin 1976, 45, T. 61: 17; *Metlika-Hrib, gr. 1/31*: Grahek 2004, T. 6: 6; *Podzemelj-Grm, gr. 5/3*: Barth 1969, T. 23: 10; *Stična, gr. 48/41, 48/127, 5/26*: Gabrovec et al. 2006, T. 28: 1, 74: 1, 126: 1.

⁹⁰¹ Stare V. 1960–1961, 54, sl. 2, T. 11: 7,8.

⁹⁰² Jerin 2001, karta 2; Grahek 2004, sl. 34.

with boat fibulae are made of spiral wire of round cross-section or of flat wire with overlapping ends. There is no trace of iron ring jewellery, with the exception of Grave 10/1 from Sajevece, which revealed a unique iron bracelet with a band of sheet bronze wound round it at four places.⁸⁹⁵ Boat fibulae are usually associated with bronze bracelets, which may be spiral, plain or decorated with stripes of transverse incisions, but also ribbed and even hollow. At Dragatuš, boat fibulae appear together with spectacle and anthropomorphic pendants of the Iapodic type, in one grave even with an Apulian krater. The two females from Magdalenska gora and Sajevece also wore a diadem. At Libna, a Group 1 boat fibula after Jerin was found together with two-looped fibulae of Group 8 after Gabrovec and a fragment of a serpentine fibula with wings, a pair of bronze bracelets and triangular pendants on chains.⁸⁹⁶ Boat fibulae of Type **1b** are limited to the territory of the Dolenska community⁸⁹⁷ and appear in similar context as Type 1a, sometimes even together.⁸⁹⁸

The second most common form of fibulae in Dolenska is the boat fibulae of Group 2 after Jerin. They were documented from Dolenska to western Pannonia and even north of the Danube Bend, but only rarely to the west of the above-delimited area.⁸⁹⁹ Jerin distinguished between six types depending on the number of longitudinal ribs on the bow (2a–2f). All these types have been found at a single site only at Hallstatt. The whole range is documented also in Dolenska, but not at a single site; five of the six types were found at Libna and in the vicinity of Veliki Vinji vrh (Šmarjeta). Among the types, the best and most widely represented is Type **2b** or Type Šmarjeta (*fig.* 83: B), which was given its name from the site that yielded most examples. Numerous fibulae of this type were also found at Stična, while they are rare in Bela krajina. This type as well appears only in inhumation burials.⁹⁰⁰ They appear in combination with a Type 1a boat fibula, a three-knobbed or a serpentine fibula, with amber and glass necklaces, once also with a torque. The costume that included this fibula type often contained solid bronze bracelets, either plain, decorated with stripes of incisions or ribbed, but also

⁸⁹⁵ Guštin/Preložnik 2005, 143, Fig. 6: 3.

⁸⁹⁶ Guštin 1976, 45, T. 63: 1-7.

⁸⁹⁷ Jerin 2001, map 1; Grahek 2004, Fig. 32.

⁸⁹⁸ *Dobrníč, Gr. 7/8*: Parzinger 1988–1989, T. 9: 1; *Krajna Brda-Boršt, Tum./Set a*: Dular J. 2003, T. 52: 5; *Podzemelj-Grm, Gr. 1/8*: Barth 1969, T. 12: 3; *Roje pri Trebelnem-Laze, Gr. 1*: Dular J. 2003, T. 26: 7.

⁸⁹⁹ Teržan 1990a, map 16; Glunz 1997, Karte 24; Jerin 2001, map 2; Grahek 2004, Figs. 33, 34.

⁹⁰⁰ *Brezje, Gr. 1/34, 7/36, 13/22*: Kromer 1959a, T. 6: 7, 22: 6, 50: 5; *Čužnja vas-Osredek, Gr. 2/3*: Dular J. 2003, T. 19: 12; *Dobrníč, Gr. 1/9*: Parzinger 1988–1989, T. 2: 5; *Libna-Volavšek Tum./Gr. 6*: Guštin 1976, 45, T. 61: 17; *Metlika-Hrib, Gr. 1/31*: Grahek 2004, T. 6: 6; *Podzemelj-Grm, Gr. 5/3*: Barth 1969, T. 23: 10; *Stična, Gr. 48/41, 48/127, 5/26*: Gabrovec et al. 2006, T. 28: 1, 74: 1, 126: 1.

dolenjske skupnosti je zabeleženih vsega pet primerkov (Vače, Magdalenska gora, Suhadole, Libna in Metlika-Hrib). Najlepšo med njimi je nosila metliška deklica, pokopana v grobu 31 v gomili na Hribu. Njeno fibulo so krasili bronasti obeski v obliki kavri polžkov, razen tega je imela še štiri trortaste fibule ter dve narebreni zapestnici, tri vijčke in pet posod. Tudi na Libni je bil ta tip fibule najden skupaj s trortasto fibulo, zraven so spadali še uhani iz spiralno zvite žice.⁹⁰³ V Suhadolah pa je zabeležen en primerek v okviru plane nekropole v skeletnem grobu, ki po dodatkih odstopa od drugih oprav, saj je vseboval železen nož in železno rombično pasno spono.⁹⁰⁴

Na istem prostoru kot fibule 2. skupine se pojavljajo čolničaste fibule 6. skupine. Tip **6a** z nizkim oglatim lokom, ki je okrašen s prečnimi mrežastimi pasovi, je kartirala že Teržanova, njeno karto je dopolnila Jerinova še s tipom 6b, ki ima narebren lok.⁹⁰⁵ Tip 6a je izpričan v opravi vodilne predstavnice iz Stične (48/27), ki je imela še številne primerke tipa 3c in fibule z oblogo, pa kačaste in dolgonožno s trakastim lokom, razen tega jo je krasil zlat diadem in naglavno okrasje, jantarne in steklene ogrlice ter obročasti nakit na rokah in nogah.⁹⁰⁶ Vendar nastopa tudi v skromnejših opravah skupaj s čolničastimi fibulami 2. skupine ali tipom 1a, z rtastimi fibulami, spiralnimi žičnatimi uhani ali uhani iz sploščene žice s presegajočimi konci ter z masivnimi narebrenimi in votlimi zapestnicami.⁹⁰⁷ Posamični primerki tipa **6b** so na Dolenjskem znani z Vač, Magdalenske gore, Brezja, iz okolice Velikega Vinjega vrha (Šmarjete) in Velikih Malenc, bolj severno se pojavljajo v Hallstattu, južno pa v Donji Dolini ob Savi ter v Prozoru na japonskem teritoriju.⁹⁰⁸ V Brezju je bila taka fibula najdena v grobu 13/15 skupaj z drobno fibulo sanguisuga, zlato peno, jantarno ogrlico, številnim narebrenim obročastim nakitom (eno zapestnico in 17 nanožnicami) ter s pločevinastim bobenčkom z obeski na verižicah, ki je morda ostanek sceptru.⁹⁰⁹ Na Magdalenski gori nastopa v domnevno moškem grobu (Preloge, gr. 2/8), ki ga po svinčeni narokvici lahko datiramo v negovsko stopnjo.

Čolničaste fibule tipa **3a** so značilne za golaseško kulturno skupino, kjer so bili najdeni številni primerki v depoju v Arbedu. Z mnogimi takimi fibulami se ponasata še Este in Most na Soči, s posamičnimi pa najdišča v osrednji Sloveniji – Ljubljana, Vače, Magdalenska gora in Veliki Vinji vrh (Šmarjeta), ki predstavljajo

hollow bracelets and anklets. The two richest contexts are the graves with a diadem from Magdalenska gora (Voselca, Gr. 2/6) and Velike Malence.⁹⁰¹ Boat fibulae of Type **2d**, with a mid-rib on the bow and incised decoration on the sides, are much rarer. Apart from Hallstatt, they were documented at western Pannonian sites and in the Sava basin from Kranj to Donja Dolina.⁹⁰² In Dolenjska, altogether five examples have been noted (Vače, Magdalenska gora, Suhadole, Libna and Metlika-Hrib). The most beautiful among them was worn by a girl from Metlika, buried in Grave 31 under a tumulus at Hrib. Her fibula was adorned by bronze pendants in the shape of cowrie shells and was found together with four three-knobbed fibulae, two ribbed bracelets, three spindle whorls and five vessels. At Libna as well, the fibula type was found together with a three-knobbed fibula and spiral wire earrings.⁹⁰³ At Suhadole, another fibula was documented in a flat cemetery inside an inhumation grave, which differs from those cited above in that it contained, besides the fibula, an iron knife and an iron rhombic belt clasp.⁹⁰⁴

The distribution area of the boat fibulae of Group 2 is shared by those of Group 6. Type **6a**, with a low angular bow decorated with transverse reticulated stripes, was already mapped by Teržan. Her map was supplemented by Jerin with Type 6b fibulae with a ribbed bow.⁹⁰⁵ Type 6a was documented as part of the costume of the leading female representative from Stična (48/27), who also had numerous examples of Type 3c and fibulae with an overlay, serpentine and a long-footed band bow fibula, a gold diadem and other head decorations, amber and glass beads as well as ring jewellery on her arms and legs.⁹⁰⁶ Type 6a was also found in poorer graves together with boat fibulae of Group 2 or Type 1a, with two- or three-knobbed fibulae, spiral wire earrings or earring of flat wire with overlapping ends as well as solid ribbed and hollow bracelets.⁹⁰⁷ Individual examples of Type **6b** were found in Dolenjska at Vače, Magdalenska gora, Brezje, around Veliki Vinji vrh (Šmarjeta) and Velike Malence. North of Dolenjska, they were found at Hallstatt and to the south at Donja Dolina along the Sava and at Prozor on the Iapodic territory.⁹⁰⁸ At Brezje, such a fibula was found in Grave 13/15 together with a small leech fibula, gold-leaf remains, amber necklace, numerous pieces of ribbed ring jewellery (one bracelet and 17 anklets) and a small bronze sheet drum with pendants on chains,

⁹⁰³ Špilerjeva gomila I/1962-2: Guštin 1976, T. 5: 11.

⁹⁰⁴ Gr. 5: Dular J. 2003, T. 91: 5.

⁹⁰⁵ Teržan 1990a, karta 15; Smolnik 1994, 103 ss, Abb. 17, T. 51: 5; Glunz 1997, Karte 25; Jerin 2001, karta 4.

⁹⁰⁶ Gabrovec et al. 2006, T. 18: 34.

⁹⁰⁷ Brezje, gr. 7/34: Kromer 1959a, T. 32: 2; Libna-Deržaničeva gom. I/gr. 1: Guštin 1976, T. 11: 2,4; Stična, gr. 48/167: Gabrovec et al. 2006, T. 96: 1.

⁹⁰⁸ Jerin 2001, karta 4.

⁹⁰⁹ Kromer 1959a, 70, T. 48: 4.

⁹⁰¹ Stare V. 1960–1961, 54, Fig. 2, T. 11: 7,8.

⁹⁰² Jerin 2001, map 2; Grahek 2004, Fig. 34.

⁹⁰³ Špiler Tum. I/1962-2: Guštin 1976, T. 5: 11.

⁹⁰⁴ Gr. 5: Dular J. 2003, T. 91: 5.

⁹⁰⁵ Teržan 1990a, map 15; Smolnik 1994, 103 ff, Abb. 17, T. 51: 5; Glunz 1997, Karte 25; Jerin 2001, map 4.

⁹⁰⁶ Gabrovec et al. 2006, T. 18: 34.

⁹⁰⁷ Brezje, Gr. 7/34: Kromer 1959a, T. 32: 2; Libna-Deržanič Tum. I/Gr. 1: Guštin 1976, T. 11: 2,4; Stična, Gr. 48/167: Gabrovec et al. 2006, T. 96: 1.

⁹⁰⁸ Jerin 2001, map 4.

najvzhodnejšo mejo njihove razprostranjenosti.⁹¹⁰ V ljubljanskem grobišču je en tak primer ek zastopan v žganem grobu 267 s kamnito skrinjo, v kateri je stala žara z obilico bronastega obročastega nakita (tordirana ovratnica, dva velika trakasta narebrena obsenčnika, deset gladkih nanožnic) in z jantarno ogrlico.⁹¹¹ Tudi na Magdalenski gori je bila najdena v žganem grobu, kjer so jo našli skupaj z dvema masivnima bronastima zapestnicama v t. i. svetolucijskem pitosu (Laščik, gr. 1892/13). Žgan pokop, svetolucijski pitos ter fibula tipa 3a govorijo o povezavah s svetolucijskim oz. estenskim prostorom. Tudi čolničaste fibule tipa 3b bi lahko pripisali svetolucijskemu izdelovalnemu krogu v času stopnje Sv. Lucija IIa.⁹¹² To različico zasledimo med najdbami skeletnega groba X/72 z Magdalenske gore in predstavlja za zdaj edini znani primer ek na območju dolenske halštatske skupnosti. K opravi pokojnice so menda spadale še masivne in votle zapestnice, zlata folija, jantarna ogrlica ter kačasta fibula s krilci, ki je značilna za stopnjo kačastih fibul. V znamenitem grobu 48/27 iz Stične pa srečamo zelo majhne čolničaste fibule tipa 3c.⁹¹³ Dva primerka tega tipa sta bila najdena tudi na Magdalenski gori, toda inventarizirana grobna celota z Voselce (2/19) ni zanesljiva. Mednje se nemara uvršča primer ek iz Novega mesta, kjer je bil najden v skeletnem grobu 16/34 na Kapiteljski njivi skupaj z dvozankasto fibulo tipa 5a.⁹¹⁴ Čolničaste fibule 3. skupine so dolenski noši precej tuje, saj se pojavljajo v glavnem le na severozahodnih najdiščih in kažejo na stike s skupnostmi na zahodu, zlasti s svetolucijsko,⁹¹⁵ morda bi jih lahko uvrstili celo med importe.

Na splošno označujejo čolničaste fibule novo epizodo v razvoju dolenske halštatske noše. Najprej se je s severnoitalskega prostora razširila moda velikih fibul 1. skupine po Jerinovi, ki je zajela južne in vzhodne Alpe. Na teritoriju dolenske skupnosti je izpodrinila "domače" vaške fibule (= tip 5a po Gabrovcu), s katerimi se nikoli ne pojavljajo skupaj. Resda obe vrsti fibul v opravah pogosto nastopata samostojno kot edina zaponka, res pa je tudi, da čolničaste fibule niso bile najdene v kombinaciji z železnim obročastim nakitom, s katerim se pogosto povezujejo dvozankaste vozlaste fibule tipa 5a po Gabrovcu. Izjemo predstavlja omenjeni grob iz Sajevc z unikatno železno zapestnico, ovito z bronastim trakom, ki spominja na podobno izdelano ovratnico iz picenskega najdišča Montedinova.⁹¹⁶ Čolničastim fibu-

⁹¹⁰ Parzinger 1988, T. 142, 1: 3; Jerin 2001, karta 3.

⁹¹¹ Puš 1982, T. 3: 4.

⁹¹² Jerin 2001, 38 ss, karta 4.

⁹¹³ Gabrovec et al. 2006, T. 18: 27-33.

⁹¹⁴ Križ et al. 2009, 114.

⁹¹⁵ Jerin 2001, karta 3.

⁹¹⁶ Lucentini 1992, 469, Fig. 4: 2; Kruta Poppi 1995, Fig. 4.

which may represent the remains of a sceptre.⁹⁰⁹ At Magdalenska gora, such a fibula belonged to a presumably male grave (Preloge, Gr. 2/8), dated to the Negova phase on the basis of a lead armlet.

Boat fibulae of Type 3a are typical of the Golasecca cultural group, within which numerous examples of the fibula type were found in a hoard at Arbedo. Many such fibulae were also found at Este and Most na Soči, while individual ones came to light in central Slovenia, namely Ljubljana, Vače, Magdalenska gora and Veliki Vinji vrh (Šmarjeta), which also trace the eastern border of the fibula type's distribution.⁹¹⁰ In the Ljubljana cemetery, one example belonged to cremation Grave 267 with a stone cist, which contained an urn with a multitude of bronze ring jewellery (twisted torque, two large ribbed band temple-rings, ten plain anklets) and an amber necklace.⁹¹¹ At Magdalenska gora, such a fibula was also found in a cremation grave, together with two solid bronze bracelets inside a Sveta Lucija pithos (Laščik, Gr. 1892/13). Cremation burial, Sveta Lucija pithos and a Type 3a fibula all speak of connections with the Sveta Lucija or Este communities. Boat fibulae of Type 3b could also be attributed to the Sveta Lucija production circle, from the Sv. Lucija IIa phase.⁹¹² A fibula of this type is published among the goods of inhumation Grave X/72 from Magdalenska gora and represents the only thus far known example of the type on the territory of the Dolenska community. The female buried in this grave was also offered solid and hollow bracelets, gold foil, an amber necklace and a serpentine fibula with wings, the latter characteristic of the Serpentine Fibulae phase. In the famous Grave 48/27 from Stična, on the other hand, very small boat fibulae of Type 3c were found.⁹¹³ Two examples of this type were also documented at Magdalenska gora, though their grave group from Voselca (2/19), as inventoried, is not reliable. The type may further include an example from Novo mesto, found in inhumation Grave 16/34 at Kapiteljska njiva together with a two-looped fibula of Type 5a.⁹¹⁴ Boat fibulae of Group 3 are a foreign element to the Dolenska costume and only appear in the north-western sites. They indicate contacts with the communities living to the west, particularly that of Sveta Lucija,⁹¹⁵ and may even be seen as imports.

Boat fibulae (*Kahnfibeln*) in general mark a new chapter in the development of the Early Iron Age costume of Dolenska. First to spread to the southern and eastern

⁹⁰⁹ Kromer 1959a, 70, T. 48: 4.

⁹¹⁰ Parzinger 1988, T. 142, 1: 3; Jerin 2001, map 3.

⁹¹¹ Puš 1982, T. 3: 4.

⁹¹² Jerin 2001, 38 ff, map 4.

⁹¹³ Gabrovec et al. 2006, T. 18: 27-33.

⁹¹⁴ Križ et al. 2009, 114.

⁹¹⁵ Jerin 2001, map 3.

lam so bile verjetno sočasne dvoankaste fibule z votlim lokom (= tip 1v), ki so izdelane na podoben način. Da so domači rokodelci že obvladovali zapleten tehnološki postopek ulivanja, nedvomno dokazujejo čolničaste fibule tipa 1b in primerki z železno iglo, ki so omejeni zgolj na dolenski prostor.

Drugo razvojno fazo in pot označujejo t. i. šmarješke fibule in njeni derivati (2. skupina po Jerinovi), ki so na Dolenjskem prišle v modo v fazi Stična 2. Razširile so se po vzhodnoalpskih deželah in še dlje proti severu, medtem ko jih v zahodnih pokrajinah ne srečamo. Na istem prostoru in bolj ali manj sočasno se pojavljajo tudi fibule z nizkim sploščenim lokom (tip 6a in 6b), ki se na Dolenjskem niso tako uveljavile, v Beli krajini pa sploh niso znane.

Če primerjamo zastopanost dvoankastih in čolničastih fibul po najdiščih (*sl.* 83: A), lahko zaznamo določene razlike znotraj teritorija dolenske skupnosti. Vaške dvoankaste fibule (tip 5a) so najpogostejše na severozahodnih najdiščih (Vače, Stična), dvoankaste fibule tipov 6a in 8 pa so številnejše na najdiščih ob spodnjem toku Krke (Libna in okolica Velikega Vinjega vrha oz. Šmarjete), medtem ko primerki dvoankastih fibul z votlim lokom (tip 1v) na Libni in v Beli krajini niso znani. Na drugi strani so čolničaste fibule 1. skupine najmočnejše zastopane v Beli krajini in v okolici Velikega Vinjega vrha, manj pa na severozahodnih najdiščih, zato pa na slednjih zasledimo čolničaste fibule 3. skupine, ki so v Beli krajini neznane, enako velja za 6. skupino. Te razlike med najdišči bi lahko razumeli kot izraz lokalnih posebnosti v starejšem halštatskem obdobju, pri čemer je odigrala svojo vlogo tudi njihova geografska lega v mreži prometnih tokov med zahodom in vzhodom, severom in jugom.

Alps from the north Italian area was the fashion for large fibulae of Group 1 after Jerin. In Dolenjska, it ousted the "local" Vače fibulae (= Type 5a after Gabrovec), with which they never appeared together in graves. It is true that both types usually appear as the only fibula of the costume, but it is also true that boat fibulae were practically never found in combination with iron ring jewellery, which is often associated with the two-looped knobbed fibulae of Type 5a after Gabrovec. There is one exception, namely the above-mentioned grave from Sajevce, with the unique iron bracelet with a bronze band wound round it, which is reminiscent of the similarly made torque from the Picenum site of Montedinova.⁹¹⁶ Probably contemporary to the boat fibulae were two-looped fibulae with a hollow bow (= Type 1v), made in a similar manner. By that time, the local craftsmen mastered the complicated technological process, which is undoubtedly proven by boat fibulae of Type 1b and the examples with an iron pin, limited to the area of Dolenjska.

The second phase of development, but also a different path of influence, is marked by the Šmarjeta fibulae and its derivatives (Group 2 after Jerin). These became fashionable in Dolenjska in the Stična 2 phase. They spread across the eastern Alps and further to the north, while they are not known to the west. The Šmarjeta fibulae share their distribution area, but roughly also their chronology, with the fibulae with a low flattened bow (Types 6a and 6b), whereby the latter were not as popular in Dolenjska and are not known at all in Bela krajina.

The comparison of the representation of two-looped and boat fibulae at individual sites (*fig.* 83: A) indicates certain differences within the territory of the Dolenjska community. The Vače two-looped fibulae (Type 5a), for example, are most common on the north-western sites (Vače, Stična), the two-looped fibulae of Types 6a and 8 appear most numerous at the sites along the lower reaches of the Krka (Libna and around Veliki Vinji vrh (Šmarjeta)), while the examples of two-looped fibulae with a hollow bow (Type 1v) are not known at Libna and in Bela krajina. On the other hand, boat fibulae of Group 1 are best represented in Bela krajina and around Veliki Vinji vrh and less at the north-western sites, while the latter yielded boat fibulae of Group 3 unknown in Bela krajina. The same holds true of Group 6. These differences could be understood as an expression of a local character in the Early Hallstatt period, also influenced by their position within the network of communications between the east and the west, between the north and the south.

⁹¹⁶ Lucentini 1992, 469, Fig. 4: 2; Kruta Poppi 1995, Fig. 4.

4.7.4 DVO- ALI TRORTASTE FIBULE

Magdalenskogorski repertoar fibul bogatijo primerki, ki imajo na loku dva ali tri gumbke (sl. 84, 85). Trortaste fibule z območja današnje Slovenije je zbrala in ovrednotila Marija Ogrin, ki jih je tipološko razporedila v enajst vrst, te pa na posamezne inačice glede na presek loka ter oblikovanost noge in zaključka.⁹¹⁷ Nekatere oblike trortastih fibul s tega prostora je zatem obravnaval Andrej Preložnik, ki je kot pomemben kriterij pri ločevanju tipov upošteval obliko zaključka noge.⁹¹⁸ Posameznim tipom je dal svoja imena (npr. tip Metlika, tip Stična), podobno kot je razne oblikovne variante z imeni najdišč označevala Fulvia Lo Schiavo; na njeno nomenklaturu se opirajo še nekateri drugi avtorji.⁹¹⁹

TRORTASTE FIBULE

Tipološke značilnosti. Poglavitna značilnost tovrstnih predmetov je zajeta že v sami oznaki, tj. število gumbkov oz. izrastkov na loku. Glede tipološke delitve si avtorji niso povsem edini. Ogrinova je primerke z izvotljenim lokom označila za trortaste fibule vrste **I** in jih razdelila na deset inačic.⁹²⁰ Magdalenskogorsko zaponko iz groba VI/2 s Prelog je opredelila kot inačico **Id** (sl. 84: 1),⁹²¹ vendar je bolj podobna njeni inačici **Ia**, ki je zastopana v Este, na Mostu na Soči in v Kobaridu.⁹²² Večino primerkov njene prve vrste obravnava Egg kot fibule s čolničastim lokom s tremi gumbki, med katere je vključil še bogato okrašeno različico, ki je poznana iz notranjealpskih dolin.⁹²³

V vrsto **II** trortastih fibul je Ogrinova uvrstila fragment loka, ki smo ga objavili med posamičnimi najdbami z Magdalenske gore.⁹²⁴ Ob reviziji prazgodovinske zbirke Narodnega muzeja v Ljubljani pa se je izkazalo, da ta kos verjetno spada k najdbi z Vinkovega Vrha.⁹²⁵

Več primerkov z Magdalenske gore spada v njeno vrsto **V**. Fibulo iz groba VII/40 s Prelog (sl. 84: 2)⁹²⁶ je pripisala inačici **Vb**, medtem ko jo je Egg označil za tip Grottazzolina.⁹²⁷ Nekatere fibule iz te skupine je anali-

⁹¹⁷ Ogrin 1998.

⁹¹⁸ Preložnik 2007a.

⁹¹⁹ Lo Schiavo 1970; Egg 1996, 187 ss, Abb. 114.

⁹²⁰ Ogrin 1998, 105 ss, sl. 9.

⁹²¹ Hencken 1978, Fig. 174c.

⁹²² *Este*: von Eles Masi 1986, T. 110: 1312; *Kobarid*: Gabrovec 1976–1977, T. 10: 4; *Most na Soči*: Teržan/Lo Schiavo/Trampuž-Orel 1984, T. 193A: 1, 241A: 5.

⁹²³ Egg 1996, 190, Abb. 116: 2, 120.

⁹²⁴ Tecco Hvala/Dular/Kocuvan 2004, T. 152: 8; Ogrin 1998, 109, sl. 10.

⁹²⁵ Ta lok fibule se natanko prilega nogi fibule, ki izvira z Vinkovega vrha in ima inv. št. P 11704; za ta podatek se Andreju Preložniku najlepše zahvaljujem.

⁹²⁶ Hencken 1978, 261j.

⁹²⁷ Egg 1996, 196, Abb. 124: 12; Ogrin 1998, 111 s, sl. 13: b.

4.7.4 TWO- OR THREE-KNOBBED FIBULAE

The Magdalenska gora collection includes several examples of fibulae with two or three protuberances or knobs on the bow (fig. 84, 85). The so-called three-knobbed fibulae (*Dreiknopffibeln*) found on the territory of present-day Slovenia were collectively analysed and evaluated by Marija Ogrin. She distinguished between eleven types, which she further subdivided into several variants, based on the cross-section of the bow and the shape of the foot.⁹¹⁷ Some forms of three-knobbed fibulae from the above-mentioned area were later re-examined by Andrej Preložnik, who used the shape of the foot terminal as the distinguishing criterion.⁹¹⁸ He proposed new names for individual types (for example Type Metlika, Type Stična), using the names of sites. Fulvia Lo Schiavo also proposed site names for certain types of fibulae, whereby her nomenclature is used by several other authors.⁹¹⁹

THREE-KNOBBED FIBULAE

Typological characteristics. The main characteristic of these fibulae is immanent in the name, namely one central and two lateral protuberances on the bow. Their typological division, however, is not uniform. Ogrin, for example, marked the fibulae with a hollowed-out bow as Type **I**, which she subdivided into ten variants.⁹²⁰ One fibula of this type was found at Magdalenska gora, more precisely in Grave VI/2 at Preloge, which Ogrin marked as Variant **Id** (fig. 84: 1),⁹²¹ though it is closer to her Variant **Ia** represented at Este, Most na Soči and Kobarid.⁹²² Most of the examples of Ogrin's Type **I** are treated by Egg as fibulae with a boat-shaped bow with three knobs (*Kahnfibeln mit Dreiknopfzier*), to which he further included a richly decorated variant known from the central Alpine valleys.⁹²³

Ogrin's Type **II** includes a bow fragment published among stray finds from Magdalenska gora.⁹²⁴ The revision of the prehistoric collection of the museum in Ljubljana, however, showed that the fragment in question was probably found at Vinkov Vrh.⁹²⁵

⁹¹⁷ Ogrin 1998.

⁹¹⁸ Preložnik 2007a.

⁹¹⁹ Lo Schiavo 1970; Egg 1996, 187 ff, Abb. 114.

⁹²⁰ Ogrin 1998, 105 ff, Abb. 9.

⁹²¹ Hencken 1978, Fig. 174c.

⁹²² *Este*: Eles Masi 1986, T. 110: 1312; *Kobarid*: Gabrovec 1976–1977, T. 10: 4; *Most na Soči*: Teržan/Lo Schiavo/Trampuž-Orel 1984, T. 193A: 1, 241A: 5.

⁹²³ Egg 1996, 190, Abb. 116: 2, 120.

⁹²⁴ Tecco Hvala/Dular/Kocuvan 2004, T. 152: 8; Ogrin 1998, 109, Abb. 10.

⁹²⁵ This bow fragment forms a whole with the foot from Vinkov vrh with Inv. No. P 11704. This information was kindly provided by Andrej Preložnik.

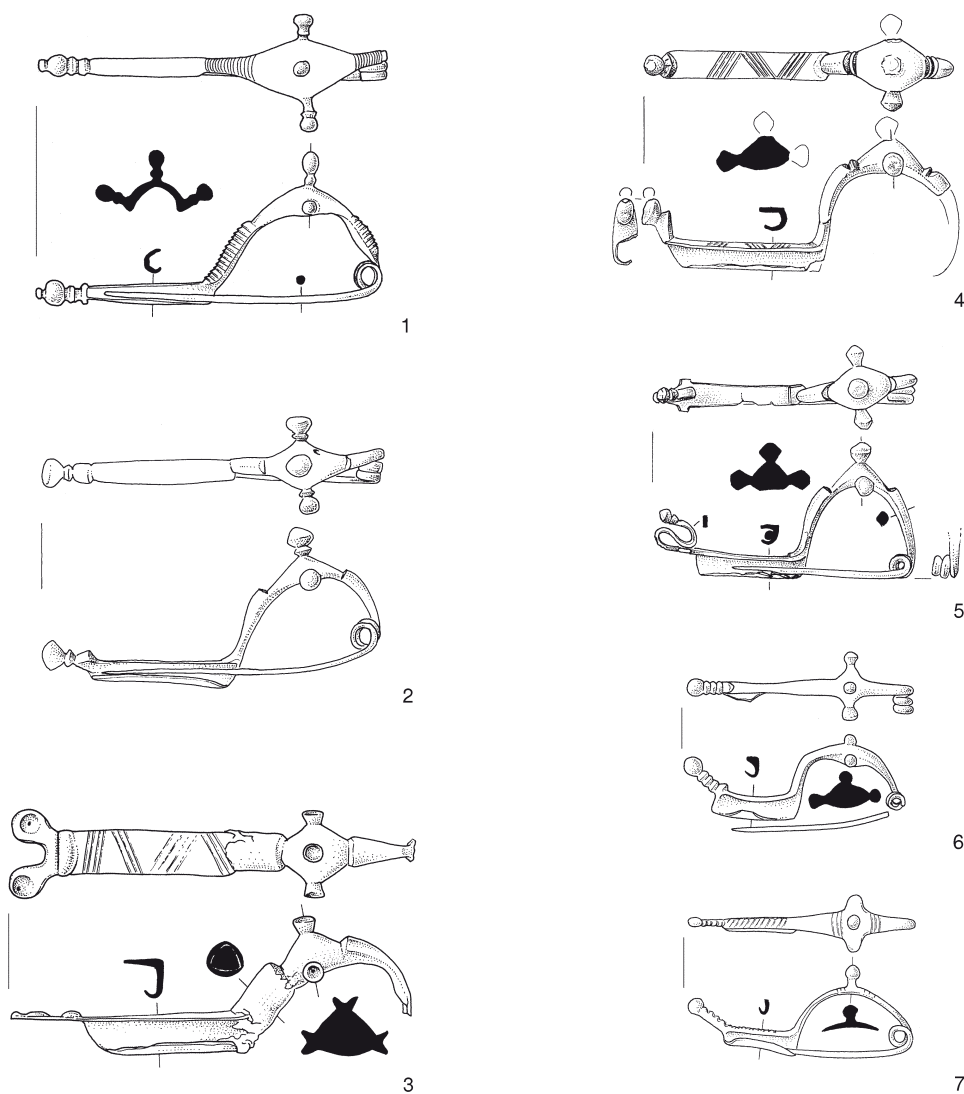

Sl. 84: Tipi trortastah fibul (po Ogrinovi, Lo Schiavovi in Preložniku) z Magdalenske gore. M. = 1:2.
 Fig. 84: Types of three-knobbed fibulae (after Ogrin, Lo Schiavo and Preložnik) from Magdalenska gora. Scale = 1:2.
 1 – Preloge, gr. 2/48 (I); 2 – Preloge, gr. VII/40 (Vb = Grottazzolina); 3 – Voselca, Tum. 6 (Vib = Numana);
 4 – najdba iz Mecklenburške zbirke v NMS / find from the Mecklenburg Collection in the NMS (= Metlika);
 5 – najdba iz Mecklenburške zbirke v NMS / find from the Mecklenburg Collection in the NMS (Vc = Stična);
 6 – Voselca, Tum. 1 (VII = Vinkov Vrh); 7 – Voselca, gr. 2/21 (VII = Vinkov Vrh).

ziral Preložnik, ki v seznamu najdišč navaja dva doslej neobjavljena primerka z Magdalenske gore med najdbami iz zapuščine vojvodinje Mecklenburške v muzeju v Ljubljani. Opredelil ju je kot tip Metlika (sl. 84: 4), ki ima na koncu noge človeško doprsko figurico oz. glavico, ter tip Stična z zaključkom v obliki črke S (sl. 84: 5), ki ga Ogrinova označuje kot inačico Vc.⁹²⁸

⁹²⁸ Preložnik 2007a, 130, Fig. 3. Ugotovil je, da pripadata lok z inv. št. P11867 in noga z inv. št. P 11876 eni fibuli, ki jo je definiral kot tip Stična. Prav tako sta komplementarna lok z inv. št. P 11868 in noga fibule z inv. št. P 11878, ki jo je opredelil kot tip Metlika. Na kartotečnih listih je kot najdišče

Several fibulae from Magdalenska gora fall into Ogrin's Type V. The fibula from Grave VII/40 at Preloge (fig. 84: 2)⁹²⁶ was ascribed to Variant Vb, while Egg marked it as Type Grottazzolina.⁹²⁷ Some of the fibulae of this type were also analysed by Preložnik, who cited further two thus far unpublished examples from Magdalenska gora excavated by the Duchess of Mecklenburg and kept in the museum in Ljubljana. He marked them as Type Metlika (fig. 84: 4), with either a human bust or a head as the foot

⁹²⁶ Hencken 1978, 261j.

⁹²⁷ Egg 1996, 196, Abb. 124: 12; Ogrin 1998, 111 f, Abb. 13: b.

Veliko fibulo z dvema rozetama oz. očescema na zaključku noge ter s čašasto oblikovanimi gumbki na loku (*sl. 84: 3*)⁹²⁹ je vključila v inačico **VIb**; primerke te inačice je Preložnik razdelil na tip Libna in tip Numana (k slednjemu je pripisal magdalenskogorsko fibulo), medtem ko Egg zanje uporablja oznako tip Grottazzolina z razcepljeno nogo.⁹³⁰

Drobne trortaste fibule z gladkim nerazčlenjenim lokom ter z izrazito privzdignjenim profiliranim zaključkom noge, ki so na Magdalenski gori zastopane s šestimi kosi,⁹³¹ je Ogrinova opredelila kot vrsto **VII** (*sl. 84: 6, 7*); zanje se uporablja tudi oznaka tip Vinkov vrh.⁹³²

Lega in kontekst. Trortaste fibule so bile na Magdalenski gori najdene v gomilah na Prelogah in na Voselci, medtem ko jih na Laščiku niso odkrili. Fibulo s čolničastim lokom vrste **I** po Ogrinovi zasledimo v žarnem grobu VI/2 in skeletnem grobu 2/48 s Prelog (*sl. 84: 1*). Pečnik in Rutar sta ocenila, da je bila v grobu 2/48 pokopana deklica, stara med 14 ali 16 let, na vsaki nogi je imela po osem nanožnic, na rokah pa narebrenne zapestnice. Fibulo, na kateri sta visela dva velika trakasta obsenčnika, je imela na prsih, ob glavi pa dva spiralna žičnata uhana. O žarnem grobu VI/2 s Prelog Goldberg poroča, da je bil odkrit blizu sredine gomile in 20 cm pod površjem. Rdečkasta žara z ostanki kosti je bila pokrita s kamnito ploščo, ob njej je stal črn lonec, v žganinski plasti pa je ležalo štirinajst nanožnic, dve manjši zapestnici (otroški) in jantarne jagode.

Fibulo tipa **Vb** po Ogrinovi oz. tip Grottazzolina (*sl. 84: 2*) objavlja Hencken med prdatki večkrat citirane vodilne predstavnice iz časa stopnje Stična 2 (Preloge, gr. VII/40), toda ni povsem gotovo, da je zares spadala v njeno okrasje. Goldberg namreč v tem kontekstu govori o sedmih fibulah s stekleno oblogo ter še o dveh čolničastih in eni "halštatski fibuli z verižico in obeskom", kar se ne ujema v celoti s prikazanim stanjem v objavi.

Velika fibula z dvema ušescema na koncu noge (*sl. 84: 3*), tj. inačica **VIb** po Ogrinovi, po Preložniku pa tip Numana oz. tip Grottazzolina z razcepljeno nogo po Eggu, izvira iz Schulzovega izkopavanja gomile 6 na Voselci leta 1882/83, o čemer poroča Dežman; natančnejše okoliščine te najdbe niso zabeležene.

Drobne fibule z dolgim privzdignjenim zaključkom noge, ki predstavljajo vrsto **VII** po Ogrinovi in napisana Magdalenska gora, v primeru noge P 11876 je v opombi zapisano, da je predmet izročila Blejska občina leta 1948. Izris predmetov in vpogled v kartoteko mi je omogočila dr. Neva Trampuž-Orel, za kar si ji najlepše zahvaljujem. Fibuli sta na tem mestu prvič objavljeni, narisala pa ju je Dragica Knific Lunder.

⁹²⁹ Tecco Hvala/Dular/Kocuvan 2004, T. 143C: 1.

⁹³⁰ Egg 1996, Abb. 114: 2; Ogrin 1998, 112, sl. 14: b; Preložnik 2007a, 124, 130, Fig. 2: a,b.

⁹³¹ Hencken 1978, Fig. 4c, 65a,b, 167c; Tecco Hvala/Dular/Kocuvan 2004, T. 130B: 4, 139B: 17.

⁹³² Egg 1996, 196, Abb. 114: 6; Ogrin 1998, 113, sl. 15.

terminal, and Type Stična with an S-shaped foot terminal (*fig. 84: 5*), which Ogrin determined as Variant **Vc**.⁹²⁸

Ogrin included the large fibula with a pair of rosettes or eyes at the end of the foot and cup-shaped knobs on the bow (*fig. 84: 3*)⁹²⁹ into her Variant **VIb**. Preložnik, on the other hand, divided the variant into Types Libna and Numana (the latter included the fibula from Magdalenska gora), while Egg marked them as Type Grottazzolina with a split foot (*Type Grottazzolina mit gespaltenem Fuß*).⁹³⁰

Small three-knobbed fibulae with a plain and simple bow as well as a pronouncedly raised and moulded foot terminal, represented at Magdalenska gora with six examples,⁹³¹ were marked by Ogrin as Type **VII** (*fig. 84: 6, 7*). They are also named Type Vinkov vrh.⁹³²

Position and context. At Magdalenska gora, three-knobbed fibulae were documented in tumuli at Preloge and Voselca, while none had come to light at Laščik. A fibula with a boat-shaped bow of Type **I** after Ogrin was found in urn Grave VI/2 and in inhumation Grave 2/48 at Preloge (*fig. 84: 1*). Pečnik and Rutar determined the deceased in Grave 2/48 to be a 14- to 16-year-old girl, who wore eight anklets on each leg and ribbed bracelets on her arms. The fibula, with two large band temple-rings hanging from it, rested on her chest, while found beside her head were two spiral wire earrings. As for urn Grave VI/2, Goldberg reports that it was found near the centre of the tumulus and 20cm under the surface. It contained a reddish urn with bone remains covered by a stone slab, with a black jar standing next to it. Lying on top of the burnt layer were fourteen anklets, two small (child's) bracelets and amber beads.

A Type **Vb** after Ogrin or Type Grottazzolina fibula (*fig. 84: 2*) is published by Hencken among the grave goods of the often cited leading female representative from the Stična 2 phase (Preloge, Gr. VII/40). However, it is not entirely certain whether the fibula really formed

⁹²⁸ Preložnik 2007a, 130, Fig. 3. He ascertained that the bow with Inv. No. P11867 is complementary to the foot with Inv. No. P 11876, whereby the fibula belongs to his Type Stična. The same holds true for the bow with Inv. No. P 11868 and the foot with Inv. No. P 11878, which belong to his Type Metlika. All these fragments originate from Magdalenska gora, as is evidenced by card files. In the case of fragment with Inv. No. P 11876, the file card states that the object was delivered to the museum by the Municipality of Bled in 1948. I would like to thank Neva Trampuž-Orel for allowing me to examine the card files and draw the finds. The two above-mentioned fibulae, drawn by Dragica Knific Lunder, are published here for the first time.

⁹²⁹ Tecco Hvala/Dular/Kocuvan 2004, T. 143C: 1.

⁹³⁰ Egg 1996, Abb. 114: 2; Ogrin 1998, 112, Abb. 14: b; Preložnik 2007a, 124, 130, Fig. 2: a,b.

⁹³¹ Hencken 1978, Figs. 4c, 65a,b, 167c; Tecco Hvala/Dular/Kocuvan 2004, T. 130B: 4, 139B: 17.

⁹³² Egg 1996, 196, Abb. 114: 6; Ogrin 1998, 113, Abb. 15.

so poznane tudi kot tip Vinkov Vrh (*sl.* 84: 6, 7), so na Magdalenski gori zabeležene v štirih grobnih celotah z različnih koncev nekropole ter kot posamična najdba iz voselške gomile 1, vendar sta bolj ali manj zanesljivi le dve grobni celoti. Ena taka zaponka je bila najdena v grobu 2/21 na Voselci skupaj z vzhodnoalpsko živalsko fibulo, dvema tankima narebrenima zapestnicama, z valjastimi uhani in jantarno ter raznobarvno stekleno ogrlico. Med pridatki so inventarizirani še železen prstan in dva obeska iz tanke bronaste pločevine, ki jih Pečnik ne omenja. O grobu V/47 z Laščika, ki je domnevno vseboval tako fibulo, pa Goldberg piše, da je bil odkrit na vzhodnem robu gomile in 60 cm globoko. V njem so menda našli slabo ohranjeno železno sulično ost, bronasto pasno spono, štiri obročke (torej moške pridatke) ter majhno fibulo in šest jantarnih jagod, ki so ženski atribut. Objavljena grobna celota večinoma ustreza temu opisu, manjka le en obroček, odveč pa je ena pasna spona (morda tista iz ljubljanskega muzeja, ki je izdelana v predrti tehniki). Od fibule je ohranjen lok, ki ga je Ogrinova pripisala I. vrsti, vendar bolj verjetno spada k njeni vrsti VII. Manj zanesljivi sta objavljeni grobni celoti s takimi fibulami iz gomile I in IV na Prelogah. Grob IV/26 naj bi vseboval le eno zlomljeno fibulo z manjkajočim delom, objavljena pa sta dva cela primerka vrste VII. V grobu I/2 Goldberg omenja žaro, ob njej pa več fibul in zapestnic, ki so bile izpostavljene ognju, ter še železno pasno spono.

Razširjenost in časovni okvir. Geografske razsežnosti pojava trortastih fibul ponazarja kumulativna karta razprostranjenosti v Eggovi objavi, ki prikazuje njihovo koncentracijo v picenskem in v jugovzhodnoalpskem prostoru ter nakazuje prekomorsko komunikacijo med zahodno in vzhodno jadransko obalo. Vendar so doživle veliko različnih izvedb, ki so precej lokalno omejene, kar je razvidno iz analitičnega prikaza razprostranjenosti posameznih tipov. Fibule s čolničasto oblikovanim lokom (= vrsta I po Ogrinovi) se pojavljajo na ozkem območju med rekama Soča in Piavo.⁹³³ Največ različic te vrste je zastopanih na Mostu na Soči, najbolj severno najdišče predstavlja Niederrasen / Rasun di Sotto z enim primerkom, jugovzhodno mejo pa zarisujejo najdišča na območju osrednje Slovenije (Vače, Magdalenska gora, Stična), kjer so prav tako maloštevilne. Na jugozahodu je meja postavljena v Este, medtem ko južno od reke Pad niso segle. Predstavljale so kratkotrajen pojav, časovno omejen na stopnjo Sv. Lucija Ic2 v Posočju (= stopnja Stična 2 na Dolenjskem).⁹³⁴ Magdalenskogorski fibuli (Preloge, gr. VI/2 in 2/48) sta najbolj podobni izdelkom z Mosta na Soči, iz Kobarida in Este, zato niti ne preseneča, da je bil grob VI/2 žgan.

⁹³³ Egg 1996, Abb. 117, 120; Ogrin 1998, sl. 20; Nascimbene 2009, 25 ss.

⁹³⁴ Ogrin 1998, 115 ss, sl. 37.

part of her adornments, since Goldberg lists seven fibulae with a glass overlay, two boat and one "Hallstatt fibula with a chain and a pendant", which does not entirely correspond to Hencken's publication.

The large fibula with a pair of rosettes or eyes at the end of the foot (*fig.* 84: 3), of Variant **VIb** after Ogrin, Type Numana after Preložnik and Type Grottazzolina with a split foot after Egg, was found during Schulz's excavation of Tumulus 6 at Voselca in 1882/83, as reported by Dežman. The circumstances of the find, however, are not known in more detail.

Small fibulae with a long and raised foot terminal, of Type **VII** after Ogrin, also known as Type Vinkov Vrh, were documented at Magdalenska gora in four grave groups from different parts of the cemetery and as one stray find from Tumulus 1 at Voselca (*fig.* 84: 6, 7). Of these, only two grave groups are more or less reliable. One is Grave 2/21 at Voselca, where a fibula of this type was found together with an East Alpine animal-headed fibula, two thin ribbed bracelets, cylindrical earrings and one amber and one multicoloured glass necklace. Inventoried grave goods further include an iron finger-ring and two pendants of thin sheet bronze, not mentioned by Pečnik. Another grave that supposedly contained such a fibula is Grave V/47 from Laščik. As reported by Goldberg, it was found on the eastern edge of the tumulus 60cm under the surface and contained a poorly preserved iron spearhead, a bronze belt clasp, four rings (male attributes), as well as a small fibula and six amber beads (female attributes). Of these, the publication only misses one ring, while one belt clasp is superfluous (possibly the openwork belt hook kept in the Ljubljana museum). Of the fibula, only the bow is preserved, which Ogrin ascribed to Type I, though it more likely belongs to her Type VII. Less reliable groups with this fibula type are the two from Tumuli I and IV at Preloge, namely IV/26 and I/2. The former reportedly contained one broken and partly preserved fibula, while the publication lists two examples of Type VII. For the latter, Goldberg mentions an urn, beside which lay several fibulae and bracelets, exposed to fire, as well as an iron belt clasp.

Distribution and time frame. The geographic range of the three-knobbed fibulae is shown on the cumulative distribution map published by Egg. It reveals a concentration in the Picene and south-eastern Alpine areas, but also points to an overseas communication between the west and east coasts of the Adriatic. Having said that, the fibulae were produced in numerous variants with rather limited distributions, as is discernible from the analytic representation of the distributions of individual types. Fibulae with a boat-shaped bow (= Type **I** after Ogrin), for example, appear in a narrow strip between the rivers Soča and Piave.⁹³³ Most variants of the type

⁹³³ Egg 1996, Abb. 117, 120; Ogrin 1998, Abb. 20; Nascimbene 2009, 25 ff.

Drugačno pot trasirajo trortaste fibule vrst **V** in **VI** po Ogrinovi. Njena inačica **Vb** (Magdalenska gora, gr. VII/40) je pri Eggu upoštevana v okviru tipa Grottazzolina. Ta tip je razširjen od južnega dela Apeninskega polotoka vse do severnega obroba Alp, z največjo koncentracijo v picenskem prostoru, od koder se je dozdevno razširil v japonski, istrski in dolenski prostor.⁹³⁵ To pot še bolj jasno zarisujejo tipi, ki jih je izpostavil Preložnik. Gre za tipe Metlika, Stična (= **Vc** po Ogrinovi) ter Numana, Campovalano, Brezje, Malence (= vrsta **VI** po Ogrinovi).⁹³⁶ Ob tem je pomenljivo tudi to, da se fibule vrste **VI** po Ogrinovi pojavljajo samo na Dolenjskem in v Picenumu ter južni Italiji, medtem ko v estenskem prostoru, na Notranjskem in v Beli krajini niso znane; datirane pa so na konec 7. in v 6. st. pr. n. št.⁹³⁷

Najmlajše so drobne trortaste fibule s privzdignjenim zaključkom noge (= vrsta **VII** oz. tip Vinkov Vrh). Ta tip je razen na Dolenjskem znan v Posočju, posamični primerki so zabeleženi še ob srednjem in južnem toku Save (Donja Dolina, Sremska Mitrovica) ter eden na japonskem teritoriju v Jezerinah, medtem ko jih v Beli krajini ni.⁹³⁸ Ogrinova sicer navaja dva kosa iz srednje Italije (Belmonte Piceno in Colfiorito di Foligno), ki pa ju je Egg označil za tip Grottazzolina. Primerek iz nekropole Colfiorito di Foligno je sodeč po merilu na objavljeni fotografiji enkrat večji od dolenskih, razen tega ima značilno obliko loka in gumbkov tipa Grottazzolina, res pa je, da po zaključku noge spominja na fibule vrste **VII** po Ogrinovi. Ta grob je tudi precej starejši, datiran je v prva desetletja 6. st. pr. n. št.,⁹³⁹ medtem ko se dolenski primerki vrste **VII** ali tipa Vinkov Vrh pojavljajo v certoški stopnji.

Iz tipo-kronološke razpredelnice, ki jo je predstavila Ogrinova, je moč izluščiti glavne tendence v razvoju trortastih fibul, ki je na Dolenjskem potekal od velikih k vse manjšim zaponkam, pa tudi k vse bolj raznolikim zaključkom noge. Pri fibulah inačic Ia–c, f, j ter vrst III, IX in X noga tekoče prehaja v vodoravno postavljen gumb (podobno kot pri čolničastih fibulah). Vse te variante so datirane v drugo polovico 7. st. pr. n. št. Pri inačicah Ie, g, h, j ter vrstah II, IV, V, VI pa je zaključek noge oddeljen in pomaknjen na zgornji rob noge. Lahko je sploščen ter različno oblikovan in zavrt. Ti tipi se sicer pojavijo že ob koncu starejšega halštatskega obdobja, uporabljajo pa se še v 6. st. pr. n. št. Najmanjše fibule so najmlajše (= vrsta **VII** po Ogrinovi); imajo precej dolg in razčlenjen zaključek noge, ki predstavlja že eno tretjino

were documented at Most na Soči. The northernmost example was found at Niederrasen / Rasun di Sotto. The south-eastern border is traced by the sites in central Slovenia (Vače, Magdalenska gora, Stična), where the type is poorly represented. The south-western border is marked by Este, while they did not appear south of the Po. The three-knobbed fibulae were short-lived and limited in the Soča Valley to the Sv. Lucija Ic2 phase (= Stična 2 phase in Dolenjska).⁹³⁴ The two fibulae from Magdalenska gora (Preloge, Gr. VI/2 and 2/48) bear most similarities with the examples from Most na Soči, Kobarid and Este. In light of that it is also not surprising that Grave VI/2 contained cremated remains.

Three-knobbed fibulae of Types **V** and **VI** after Ogrin show a different distribution. Her Variant **Vb** (Magdalenska gora, Gr. VII/40) forms part of Type Grottazzolina after Egg. This type was spread from the southern Apennine Peninsula to the northern fringes of the Alps, with the highest concentration in Picenum, whence it presumably spread to the Iapodic, Istrian and Dolenjska areas.⁹³⁵ This path is even more clearly marked by the types proposed by Preložnik, namely Types Metlika, Stična (= **Vc** after Ogrin) as well as Numana, Campovalano, Brezje and Malence (= Type **VI** after Ogrin).⁹³⁶ It is also noteworthy that fibulae of Type **VI** after Ogrin only appear in Dolenjska, Picenum and southern Italy, while they were not documented in the Este area, Notranjska and Bela krajina. They are dated to the end of the seventh and the sixth century BC.⁹³⁷

The latest three-knobbed fibulae are the small examples with a raised foot terminal (= Type **VII** or Vinkov Vrh). Apart from Dolenjska, this type is known in the Soča Valley, while individual examples were documented along the Sava (Donja Dolina, Sremska Mitrovica) and on the Iapodic territory. None came to light in Bela krajina.⁹³⁸ Ogrin cites two examples from central Italy (Belmonte Piceno, Colfiorito di Foligno), which Egg rather included in his Type Grottazzolina. The example from the cemetery at Colfiorito di Foligno is, judging from the photo, twice as big as the fibulae from Dolenjska and shows the form of the bow and the knobs characteristic of Type Grottazzolina. The grave from Colfiorito di Foligno is also considerably earlier, from the initial decades of the sixth century BC,⁹³⁹ while the Dolenjska examples of Type **VII** or Vinkov Vrh appear in the Certosa phase.

⁹³⁴ Ogrin 1998, 115 ff, Abb. 37.

⁹³⁵ Egg 1996, Abb. 118; Lo Schiavo 2010, 566 ff, T. 344: 4967-4972, 345: 4973-4984, 346: 4985-5001.

⁹³⁶ Ogrin 1998, Abb. 30, 32; Preložnik 2007a, Figs. 1-3; Lo Schiavo 2010, 572 ff, T. 348: 5027-5029, 349: 5030, 5031, 5033, 5040, 5041.

⁹³⁷ Egg 1996, 207 ff; Ogrin 1998, Abb. 37; Lo Schiavo 2010, 573.

⁹³⁸ Egg 1996, Abb. 119; Ogrin 1998, 113, Abb. 36.

⁹³⁹ Bonomi Ponzi 1986, 421 f, T. 91; Egg 1996, 191.

⁹³⁵ Egg 1996, Abb. 118; Lo Schiavo 2010, 566 ss, T. 344: 4967-4972, 345: 4973-4984, 346: 4985-5001.

⁹³⁶ Ogrin 1998, sl. 30, 32; Preložnik 2007a, Fig. 1-3; Lo Schiavo 2010, 572 ss, T. 348: 5027-5029, 349: 5030, 5031, 5033, 5040, 5041.

⁹³⁷ Egg 1996, 207 ss; Ogrin 1998, sl. 37; Lo Schiavo 2010, 573.

⁹³⁸ Egg 1996, Abb. 119; Ogrin 1998, 113, sl. 36.

⁹³⁹ Bonomi Ponzi 1986, 421 s, T. 91; Egg 1996, 191.

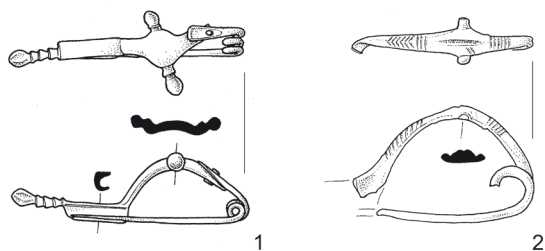

Sl. 85: Dvortasti fibuli z Magdalenske gore. M. = 1:2.
Fig. 85: Two-knobbed fibulae from Magdalenska gora.
Scale = 1:2.

1 – Voselca, gr. 2/6 (**italski tip / Italic type**);

2 – Preloge, gr. 13/126 (**alpski tip / Alpine type**).

dolžine noge in je privzdignjen navzgor pod kotom 30°, lok ni več razčlenjen, temveč okrašen s snopom prečnih vrezov na vsaki strani gumbkov. Najmlajša primerka (vrsta XI po Ogrinovi), ki sta znana iz Koritnice ob Bači in Bodreža, imata dodano samostrelno peresovino in sta datirana v stopnjo Sv. Lucija IIc.

Razvoj belokranjsko-japodskih trortastih fibul je potekal samostojno in v obratni smeri od dolenskih, se pravi od manjših k čedalje večjim fibulam in k vse širši zgornji ploskvi noge, ki je okrašena s cikcak vrezi ali vrstami vtisnjenih krožcev ter z obrazno masko na zaključku noge. Ogrinova jih je uvrstila med inačice IIc, d, f in v vrsto VIII.⁹⁴⁰ Med starejšimi primerki je zanimiva trortasta fibula iz gomile na Hribu nad Metliko (gr. 31), ki ima na zaključku noge človeško doprsno figurico.⁹⁴¹ Najdena je bila skupaj s šmarješko čolničasto fibulo ter še s tremi trortastimi fibulami inačice Va po Ogrinovi. Po njej je Preložnik fibule s človeško masko opredelil kot tip Metlika, ki so razen v Beli krajini znane še v Picenumu.⁹⁴² Časovno jim sledijo večje trortaste fibule s široko in okrašeno zgornjo ploskvijo noge ter z masivnim razčlenjenim zaključkom noge, ki je rahlo privzdignjen (= inačice II. vrste po Ogrinovi); zanje se uporablja tudi oznaka tip Kopolje.⁹⁴³ Najmlajše so velike fibule z zelo široko zgornjo ploskvijo noge, okrašeno s punciranimi krožci, ki se zaključuje z obrazno masko (= vrsta VIII po Ogrinovi oz. tip Vinica po Lo Schiavovi).⁹⁴⁴ Ob koncu starejše železne dobe so za viniško nošo značilne t. i. dvojno trortaste fibule z raztegnjenim lokom in podvojenimi gumbi.⁹⁴⁵

The typo-chronological table presented by Ogrin allow us to discern the main tendencies in the development of the three-knobbed fibulae. In Dolenjska, their development proceeded from the large towards the ever smaller examples, but also towards the more varied foot terminals. In fibulae of Variants Ia–c, f, j and Types III, IX and X, the foot shows a smooth transition into the horizontally placed knob (similarly as with boat fibulae). All these variants date to the second half of the seventh century BC. Variants Ie, g, h, j and Types II, IV, V, VI, on the other hand, have the foot terminal moved to the upper edge of the foot. The foot terminal may be flattened, variously shaped or curved. These types appear already at the end of the Early Hallstatt period, but remained in use in the sixth century BC. The smallest fibulae are also the latest (= Type VII after Ogrin); they have a rather long and moulded foot terminal, which covers a third of the foot and is raised at roughly a 30° angle. The bow is simple and decorated with a stripe of transverse incisions to each side of the knobs. The two latest examples (Type XI after Ogrin), found at Koritnica near Bača and Bodrež, have an added crossbow spring and date to the Sv. Lucija IIc phase.

The development of the Bela krajina-Iapodic three-knobbed fibulae progressed independently and in the opposite direction to the Dolenjska examples, namely from the small towards the large and towards an ever wider foot surface. The latter was decorated with zigzag incisions and rows of impressed circles, even a face mask on the foot terminal. Ogrin determined them as Variants IIc, d, f and Type VIII.⁹⁴⁰ Standing out among the early examples is the fibula found at Hrib near Metlika (Gr. 31), with the foot terminal shaped in a human bust.⁹⁴¹ It was found together with a Šmarjeta boat fibula and three three-knobbed fibulae of Variant Va after Ogrin. Fibulae with human masks were later determined as Type Metlika by Preložnik, known in Bela krajina and Picenum.⁹⁴² Chronologically, they are succeeded by large three-knobbed fibulae with a wide decorated upper foot surface as well as a massive, moulded and slightly raised foot terminal (= variant of Type II after Ogrin). These are also known as Type Kopolje.⁹⁴³ The latest in this line are the large fibulae with a very wide upper foot surface decorated with ring-and-dots and terminating in a face mask (= Type VIII after Ogrin or Type Vinica after Lo Schiavo).⁹⁴⁴ The Vinica costume at the end of the Early Iron Age is characterised by the fibulae with double sets of three knobs on a prolonged segmented bow (*Doppelten Dreiknopffibeln*).⁹⁴⁵

⁹⁴⁰ Ogrin 1998, 109, 113, sl. 10: c, d, f in sl. 16, 36, 37.

⁹⁴¹ Grahek 2004, 144 s, sl. 37, T. 6.

⁹⁴² Preložnik 2007a, 125, 130, Fig. 3.

⁹⁴³ Egg 1996, Abb. 114: 5.

⁹⁴⁴ Egg 1996, Abb. 114: 7; Ogrin 1998, sl. 16.

⁹⁴⁵ Gabrovec 1966c, 185 ss, T. 14: 1-3; Egg 1996, Abb. 114: 8; Teßmann 2001, 54 ss, Abb. 22–25.

⁹⁴⁰ Ogrin 1998, 109, 113, Abb. 10: c, d, f and Abb. 16, 36, 37.

⁹⁴¹ Grahek 2004, 144 f, Fig. 37, T. 6.

⁹⁴² Preložnik 2007a, 125, 130, Fig. 3.

⁹⁴³ Egg 1996, Abb. 114: 5.

⁹⁴⁴ Egg 1996, Abb. 114: 7; Ogrin 1998, Abb. 16.

⁹⁴⁵ Gabrovec 1966c, 185 ff, T. 14: 1-3; Egg 1996, Abb. 114: 8; Teßmann 2001, 54 ff, Abb. 22–25.

DVORTASTE FIBULE

Na Magdalenski gori sta bili najdeni tudi dve dvortasti fibuli.⁹⁴⁶ Ena je po osnovni shemi podobna trortastim, le da ima dva gumbka na loku (*sl.* 85: 1), druga je tipična predstavnica t. i. alpskih dvortastih fibul (*sl.* 85: 2). Magdalenskogorska konteksta, v katerih nastopata, nista sporna. Prva je spadala k nakitu že večkrat omenjene voselške mladenke z diademom (gr. 2/6) iz časa stopnje Stična 2. Take fibule na Dolenjskem niso prav pogoste in se pojavljajo v raznih variantah.⁹⁴⁷ V estenskih grobiščih jim lahko sledimo od stopnje Este II-srednje do Este III-pozno. Starejši tamkajšnji primerki imajo izrazito rombično razširjen lok ter manjše gumbke ob strani, noga pa je brez zaključka;⁹⁴⁸ mlajše izvedbe so manjše in imajo profiliran gumbek na koncu noge.⁹⁴⁹ Tak razvoj je opazen tudi v picenskem prostoru, kjer se v stopnji Picenum III po Lollinijevi pojavljajo dvortaste fibule brez zaključnega gumbka na nogi, medtem ko v stopnji IVA dobijo na koncu noge profiliran gumb.⁹⁵⁰ Na Mostu na Soči so take fibule datirane v stopnjo Sv. Lucija Ic2.⁹⁵¹ Magdalenskogorski fibuli so najbližji primerki z Vač, iz Mokronoga, Rovišča, Dobrniča, z Velikega Vinjega vrha (Šmarjeta) in iz Podzemlja.⁹⁵²

Alpska dvortasta fibula je bila del moške oprave iz groba 13/126 s Prelog, kar bi lahko sklepali po pridani železni sulični osti. Ta oblika je redka v jugovzhodno-alpskem svetu, od koder so znani le osamljenimi kosi iz Kobarida, z Mosta na Soči, iz Stične in z Rifnika. Zaradi uniformnosti je ta tip pritegnil mnoge raziskovalce.⁹⁵³ Datirane so v Ha D1, Parzinger jih uvršča med vodilne tipe horizonta 6 v alpskem svetu.⁹⁵⁴

Rtaste fibule so ne le kronološki kazalnik, temveč tudi smerokaz kulturnih stikov na dolge razdalje. V

⁹⁴⁶ Tecco Hvala/Dular/Kocuvan 2004, T. 111C: 1, 133: 6.

⁹⁴⁷ Preložnik 2007a, 127, Fig. 6b, 7.

⁹⁴⁸ *Este-Villa Benvenuti*, gr. 278, *Este-Casa di Ricovero*, gr. 149, 234, 235, *Este-Rebato*, gr. 187; *Bologna-Melenzani*, gr. 7: Frey 1969, Abb. 11 in 2: 14, 16: 1,11 ter T. 6: 1, 7: 32, 9: 19,20, 12: 10.

⁹⁴⁹ *Este-Villa Benvenuti*, gr. 122, 124: Frey 1969, Abb. 4: 12, s T. 22: 14.

⁹⁵⁰ Lollini 1976, T. 6: 9, 9: 5,11.

⁹⁵¹ Teržan/Trampuž 1973, 424, T. 8: 6; Teržan/Lo Schiavo/Trampuž-Orel 1984, T. 131B: 1, 135B: 3, 144A: 1, 153B: 3, 154A: 7, 157A: 1,3, 187C: 2, 192D: 2, 196B: 1, 197C: 2, 199A: 9, 209C, 234A: 4, 239B: 1250C: 1, 258G: 1, 265D: 1, 269: 17, 280: 3.

⁹⁵² *Dobrnič*, gr. 4/3, 18/33: Parzinger 1988–1989, T. 5: 3, 36: 2; *Mokronog-Slepšek, plano grobišče*: Dular J. 2003, T. 8: 5; *Rovišče*: Stare V. 1962–1963, T. 5: 4; *Podzemelj-Grm*, gr. 1/7 in *posamične najdbe*: Barth 1969, T. 11: 5; Dular J. 1978, T. 3: 7,8; *Vače*: Stare F. 1955a, T. 32: 6; *Veliki Vinji vrh (Šmarjeta)*: Stare V. 1973a, T. 19: 35,36,39, 20: 2,3.

⁹⁵³ Teržan 1990a, 102, karta 19; Glunz 1997, Karte 6; Nas-cimbene 2009, 101 s, Fig. 22, Tab. 8.

⁹⁵⁴ Parzinger 1988, T. 143: 1.

TWO-KNOBBED FIBULAE

Magdalenska gora yielded two fibulae with a knob on each side of the bow (*Zweiknopffibeln*).⁹⁴⁶ One is similar to those with three knobs in its basic form (*fig.* 85: 1), while the other is a typical representative of the Alpine two-knobbed fibulae – *Alpine Zweiknopffibeln* (*fig.* 85: 2). Their grave groups are not questionable. The first fibula adorned the often mentioned young woman with a diadem (Voselca, Gr. 2/6) from the Stična 2 phase. Such fibulae are not a common find in Dolenjska. They appeared in several variants.⁹⁴⁷ At Este, they can be traced from Este II-Middle to Este III-Late. The early examples at Este have rhomboid bow and small knobs on the side, while the foot has no terminal.⁹⁴⁸ Later examples are smaller and have a small moulded knob at the end of the foot.⁹⁴⁹ Such a development is also noticeable in Picenum. In Phase Picenum III after Lollini, two-knobbed fibulae appear without the terminal knob at the end of the foot, while in Phase IVA they gain a moulded knob.⁹⁵⁰ At Most na Soči, such fibulae are dated to the Sv. Lucija Ic2 phase.⁹⁵¹ The closest to the fibula from Magdalenska gora, however, are the examples from Vače, Mokronog, Rovišče, Dobrnič, Veliki Vinji vrh (Šmarjeta) and Podzemelj.⁹⁵²

The other, Alpine two-knobbed fibula from Grave 13/126 at Preloge formed part of the male costume, as is indicated by the iron spearhead also found in the grave. This fibula form is rare in the south-eastern Alps, with individual finds known from Kobarid, Most na Soči, Stična and Rifnik. Their uniformity drew the attention of numerous researchers.⁹⁵³ They date to Ha D1, while Parzinger ranks them among the leading types of Horizon 6 in the Alps.⁹⁵⁴

Fibulae with two or three knobs on the bow (*Zwei- / Dreiknopffibeln*) serve not only as a chronological indica-

⁹⁴⁶ Tecco Hvala/Dular/Kocuvan 2004, T. 111C: 1, 133: 6.

⁹⁴⁷ Preložnik 2007a, 127, Figs. 6b, 7.

⁹⁴⁸ *Este-Villa Benvenuti*, Gr. 278, *Este-Casa di Ricovero*, Gr. 149, 234, 235, *Este-Rebato*, Gr. 187; *Bologna-Melenzani*, Gr. 7: Frey 1969, Abb. 11 and 2: 14, 16: 1,11, T. 6: 1, 7: 32, 9: 19,20, 12: 10.

⁹⁴⁹ *Este-Villa Benvenuti*, Gr. 122, 124: Frey 1969, Abb. 4: 12, T. 22: 14.

⁹⁵⁰ Lollini 1976, T. 6: 9, 9: 5,11.

⁹⁵¹ Teržan/Trampuž 1973, 424, T. 8: 6; Teržan/Lo Schiavo/Trampuž-Orel 1984, T. 131B: 1, 135B: 3, 144A: 1, 153B: 3, 154A: 7, 157A: 1,3, 187C: 2, 192D: 2, 196B: 1, 197C: 2, 199A: 9, 209C, 234A: 4, 239B: 1250C: 1, 258G: 1, 265D: 1, 269: 17, 280: 3.

⁹⁵² *Dobrnič*, Gr. 4/3, 18/33: Parzinger 1988–1989, T. 5: 3, 36: 2; *Mokronog-Slepšek, flat cemetery*: Dular J. 2003, T. 8: 5; *Rovišče*: Stare V. 1962–1963, T. 5: 4; *Podzemelj-Grm*, Gr. 1/7 and *stray finds*: Barth 1969, T. 11: 5; Dular J. 1978, T. 3: 7,8; *Vače*: Stare F. 1955a, T. 32: 6; *Veliki Vinji vrh (Šmarjeta)*: Stare V. 1973a, T. 19: 35,36,39, 20: 2,3.

⁹⁵³ Teržan 1990a, 102, map 19; Glunz 1997, Karte 6; Nas-cimbene 2009, 101 f, Fig. 22, Tab. 8.

⁹⁵⁴ Parzinger 1988, T. 143: 1.

dolenjski halštatski skupnosti so na splošno manj običajne (n = cca. 122 po Ogrinovi) od sočasnih čolničastih fibul (n = cca 349). Zasedimo jih praviloma v skeletnih grobovih in v ženskih oz. dekliških opravah, pogosto nastopajo v večjem številu in skupaj z drugimi oblikami zaponk. V stiskem grobu 5/27 najdemo fibuli vrste I v kombinaciji z "ježevkama";⁹⁵⁵ primerki vrst II, Va in VI se pojavljajo skupaj s čolničastimi fibulami, v Novem mestu pa tudi z dvoankastima fibulama tipov 6a in 8 po Gabrovcu.⁹⁵⁶ Drobne trortaste fibule vrste VII srečamo v kombinacijah z mlajšimi tipi fibul – s kačasto fibulo s trakasto zanko ter s certoškimi vrste V po Teržanovi.⁹⁵⁷

Na svetolucijski krog se navezujejo primerki s čolničasto oblikovanim lokom (vrsta I po Ogrinovi), transjadranske povezave s picenskim prostorom pa izpričujejo fibule tipa Grottazzolina (= Va po Ogrinovi). Na teritoriju dolenjske halštatske skupnosti so slednje najštevilnejše v Podzemlju in Metliki ter v okolici Velikega Vinjega vrha oz. Šmarjete, medtem ko so na drugih dolenjskih najdiščih zastopane z enim do dvema primerkoma. Picensko-dolenjska naveza je še bolj očitna v derivatih, ki jih je Preložnik opredelil kot tipe Metlika, Stična, Novo mesto, Brezje, Malence, Numana in Campoalano.⁹⁵⁸

Drobne trortaste fibule vrste VII po Ogrinovi oz. tip Vinkov vrh predstavljajo jugovzhodnoalpsko posebnost v certoški stopnji; vzdolž Save so prodrle tudi na jugovzhod (Donja Dolina, Sremska Mitrovica). Na Dolenjskem je znanih skupno 23 takih fibul (v Beli krajini jih ni), z Mosta na Soči je objavljenih 14 kosov, na svetolucijskem teritoriju se pojavlja še različica s samostrelno peresovino (v Koritnici ob Bači in Bodrežu), ki jo je Ogrinova označila za vrsto XI in jo časovno opredelila v stopnjo Sv. Lucija IIc.

Dvojno poreklo se zrcali tudi v dvortastih fibulah. Italski značaj odraža fibula iz voselškega groba 2/6, medtem ko je zaponka, najdena v grobu 13/126 na Prelogah, zagotovo prišla z alpskega območja, saj je v dolenjski noši neobičajna. Ta tip je najštevilneje zastopan v Hallstattu, na zahodu je segel vse do reke Ticino, pogost je tudi v Poadižju in v dolini reke Piave, skrajno jugovzhodna najdišča pa predstavljajo štajerski Rifnik, Donja Dolina ob spodnjem toku Save ter japonski Prozor.⁹⁵⁹

⁹⁵⁵ Gabrovec et al. 2006, T. 127: 1,2.

⁹⁵⁶ *Brezje, gr. 1/34*: Kromer 1959a, T. 6: 9; *Libna-Špilerjeva gom. I (1962)/gr. 2*; *Deržaničeva gom. I/gr. 1*: Guštin 1976, T. 5: 15, 11: 6; *Metlika-Hrib, gr. 1/31*: Grahek 2004, T. 6: 7-10; *Novo mesto-Kapiteljska njiva, gr. 2/17*: Križ 1997, T. 12: 10; *Podzemelj-Grm, gr. 1/16*: Barth 1969, T. 15: 1,4,6.

⁹⁵⁷ *Dobrnič, gr. 17/7*: Parzinger 1988–1989, T. 30: 9; *Kosmatec pri Preski, gom./gr. 10*: Guštin 1974b, T. 13: 3; *Stična, gr. 48/121*: Gabrovec et al. 2006, T. 71: 4.

⁹⁵⁸ Preložnik 2007a, Fig. 1–3, Blečić 2007, Fig. 7.

⁹⁵⁹ Nascimbene 2009, 101 ss, Fig. 21, 22, Tab. 8, s citirano starejšo literaturo.

tor, but also as a signpost of long-distance cultural contacts. In Dolenjska they are less common (122 according to Ogrin) than the contemporary boat fibulae (349). They were usually found in inhumation graves as part of the costume of either women or girls. They often appeared in groups and together with other types of fibulae. Two fibulae of type I were found in Stična in combination with a pair of fibulae with a spiky glass overlay,⁹⁵⁵ while examples of Types II, Va and VI appear together with boat fibulae, at Novo mesto also with two-looped fibulae of Types 6a and 8 after Gabrovec.⁹⁵⁶ Small three-knobbed fibulae of Type VII were found in combination with a serpentine fibula with a band bow curved into a loop and Certosa fibulae of Type V after Teržan.⁹⁵⁷

The three-knobbed fibulae with a boat-shaped bow (Type I after Ogrin) show ties with the Sveta Lucija circle, while the Type Grottazzolina (= Va after Ogrin) reveals transadriatic connections with Picenum. On the territory of the Dolenjska community, the latter fibulae were most numerous documented at Podzemelj, Metlika and around Veliki Vinji vrh (Šmarjeta), while only one or two examples were found at other sites. The connection between Picenum and Dolenjska is all the more obvious in other derivatives, determined by Preložnik as Types Metlika, Stična, Novo mesto, Brezje, Malence, Numana and Campoalano.⁹⁵⁸

Small fibulae of Type VII after Ogrin, also Type Vinkov vrh, are particular to the south-eastern Alps in the Certosa phase. They also penetrated into the south-east along the Sava (Donja Dolina, Sremska Mitrovica). In Dolenjska, altogether 23 such fibulae have so far been recorded (none in Bela krajina). Fourteen examples are published from Most na Soči, while the Sveta Lucija area also boasts the variant with a crossbow spring (at Koritnica near Bača and Bodrež), marked by Ogrin as Type XI dating from the Sv. Lucija IIc phase.

A double origin can also be perceived in the two-knobbed fibulae. The fibula from Grave 2/6 from Voselca shows an Italic character, while the fibula from Grave 13/126 from Preloge was surely brought from the Alpine area to Magdalenska gora. This type is most numerous represented at Hallstatt, reaching to the west all to the Ticino river, but was also frequent in the Adige basin and the valley of the Piave. Its south-eastern border is traced by Rifnik in Štajerska, Donja Dolina and Prozor.⁹⁵⁹

⁹⁵⁵ Gabrovec et al. 2006, T. 127: 1,2.

⁹⁵⁶ *Brezje, Gr. 1/34*: Kromer 1959a, T. 6: 9; *Libna-Špiler Tum. I (1962)/Gr. 2*; *Deržanič Tum. I/Gr. 1*: Guštin 1976, T. 5: 15, 11: 6; *Metlika-Hrib, Gr. 1/31*: Grahek 2004, T. 6: 7-10; *Novo mesto-Kapiteljska njiva, Gr. 2/17*: Križ 1997, T. 12: 10; *Podzemelj-Grm, Gr. 1/16*: Barth 1969, T. 15: 1,4,6.

⁹⁵⁷ *Dobrnič, Gr. 17/7*: Parzinger 1988–1989, T. 30: 9; *Kosmatec near Preska, Tum./Gr. 10*: Guštin 1974b, T. 13: 3; *Stična, Gr. 48/121*: Gabrovec et al. 2006, T. 71: 4.

⁹⁵⁸ Preložnik 2007a, Figs. 1–3, Blečić 2007, Fig. 7.

⁹⁵⁹ Nascimbene 2009, 101 ff, Figs. 21, 22, Tab. 8, with references.

4.7.5 FIBULE Z OBLOGO

Tipološke značilnosti. Nekatere fibule imajo na loku oblogo iz stekla,⁹⁶⁰ jantarja⁹⁶¹ ali kosti,⁹⁶² nataktnjeno na bronast žičnat lok (*sl. 86 in sl. 87*). Primerke fibul s stekleno oblogo, ki so zastopane na območju današnje Slovenije, je obdelala vodilna poznavalka prazgodovinskega stekla Thea Elisabeth Haevernick in jih je zaradi apliciranih izrastkov na oblogi imenovala “*Stachelbügelfibeln*”.⁹⁶³ V slovenščini je zanje v rabi izraz “ježevke”, z njimi pa so se ukvarjale še druge avtorice.⁹⁶⁴ Posebni vrsti fibul s stekleno oblogo, ki se pojavljajo na območju srednje in severne Italije v 8. in 7. st. pr. n. št., je namenila poglobljeno študijo Leonie Carola Koch.⁹⁶⁵ Mednje je vključila tudi primerek, ki domnevno izvira z Magdalenske gore in se razlikuje od drugih dolenskih “ježevk” po tem in da ima obloga le tri izrastke, da je bilo jedro hladno modelirano iz svetle kvarzitne peščene snovi, okoli katerega se je s segrevanjem ustvarila temnomodra steklasta plast. Obloga je še dodatno okrašena z vrezanim spiralnim, cikcak in ravnolinijskim okrasom, vložene steklene nitke pa so izpadle (*sl. 87: B*).⁹⁶⁶ Drugi primerki oblog na fibulah z Magdalenske gore so domnevno izdelani iz taljenega stekla (*sl. 86: 2–5*).

Lega in kontekst. Na Magdalenski gori so fibule s stekleno, jantarno in koščeno oblogo izpričane v najbogatejših grobovih iz največjih gomil na Prelogah. Žal sta se ohranili le dve popolni opravi s takim nakitom (VII/40 in 13/163), dve pa smo lahko samo delno rekonstruirali (2/c in 2/h). Pokojnica, pokopana v grobu 13/163 na vzhodnem robu gomile, je bila sežgana; njen pepel so posuli po grobni jami, deloma pa so ga shranili v t. i. svetlocijski pitos, v katerega so položili množico raznih nanožnic in zapestnic, ogrlice iz velikih in majhnih jantarnih jagod, tri fibule z oblogo – ena ima koščeno oblogo (*sl. 86: 6*), druga je iz turkiznega stekla, tretja pa iz modrega – razen tega je bilo pridano še uvoženo posodje in nesežgane koščice ovce ali koze. Med pridatki sta inventarizirana tudi vijček in koščena šivanka, ki ju Brattina v opisu groba ne omenja, manjkata pa obeska na fibulah, ki ju je dokumentiral v risbi (*sl. 87: A*);⁹⁶⁷ od obeska z upodobljenimi rogati živalmi so se ohranile le trikotne ploščice z nekaj členi verižice, s katerimi so

⁹⁶⁰ Hencken 1978, Fig. 261c,d,h,i,m,n; Tecco Hvala/Dular/Kocuvan 2004, T. 10A: 3, 12A: 2, 123: 7,8, 138: 14.

⁹⁶¹ Hencken 1978, Fig. 261k.

⁹⁶² Tecco Hvala/Dular/Kocuvan 2004, T. 123: 6; med najdbami brez ohranjenih grobnih celot v NMS je tudi bronasta fibula z dolgo nogo in žičnatim lokom, ki ji je obloga morebiti odpadla: *ibid.* T. 125:13.

⁹⁶³ Haevernick 1959, 57 ss, T. 5, 6.

⁹⁶⁴ Stare V. 1978; Glunz 1997, Karte 13; Kruh 2008, 112, op. 240, sl. 7.

⁹⁶⁵ Koch 2010.

⁹⁶⁶ *Ibid.*, 53, 196, Abb. 87, 276 s, Kat.-Nr. 180.

⁹⁶⁷ Tecco Hvala/Dular/Kocuvan 2004, 78, sl. 39.

4.7.5 FIBULAE WITH A BOW OVERLAY

Typological characteristics. Some fibulae have a glass,⁹⁶⁰ amber⁹⁶¹ or bone⁹⁶² overlay on the wire bow (*fig. 86 and fig. 87*). The examples with a glass overlay found on the territory of present-day Slovenia were analysed by Thea Elisabeth Haevernick, leading expert in prehistoric glass, who termed them *Stachelbügelfibeln* due to the spikes applied onto the overlay.⁹⁶³ In Slovenian, they are known as *ježevke*. Besides Haevernick, other authors also studied these fibulae.⁹⁶⁴ Those that appear in central and northern Italy in the eighth and seventh centuries BC, for example, were studied by Leonie Carola Koch.⁹⁶⁵ She included in her study a fibula supposedly found at Magdalenska gora. This example differs from other fibulae with a spiky glass overlay from Dolensjka in only three protuberances on the overlay and the core being modelled cold from a light-coloured quartz sand, the surface of which was transformed into dark blue glaze when heated. The overlay was additionally decorated with incised spiral, zigzag and rectilinear designs, while the inlaid glass threads fell out (*fig. 87: B*).⁹⁶⁶ Other examples of overlays on the fibulae from Magdalenska gora are supposedly made of molten glass (*fig. 86: 2–5*).

Position and context. At Magdalenska gora, fibulae with an amber, glass or bone overlay were found in the richest graves in the largest tumuli at Preloge. Unfortunately, only two grave groups with these fibulae are completely preserved (VII/40 and 13/163), while further two could be partially reconstructed (2/c and 2/h). The female buried in Grave 13/163 on the eastern edge of the tumulus had been cremated. Her ashes were in part strewn across the grave pit and in part stored in a Sveta Lucija pithos. The latter also contained a multitude of various anklets and bracelets, necklaces made of large and small amber beads and three fibulae with an overlay – of bone (*fig. 86: 6*), as well as turquoise and blue glass, respectively. The grave further contained imported vessels and unburnt caprovid bones. Also inventoried as part of the grave were a spindle whorl and a bone needle, which are not mentioned by Brattina in his description of the grave. Missing, on the other hand, are two fibula pendants that Brattina documented in drawing (*fig. 87: A*);⁹⁶⁷ while

⁹⁶⁰ Hencken 1978, Figs. 261c,d,h,i,m,n; Tecco Hvala/Dular/Kocuvan 2004, T. 10A: 3, 12A: 2, 123: 7,8, 138: 14.

⁹⁶¹ Hencken 1978, Fig. 261k.

⁹⁶² Tecco Hvala/Dular/Kocuvan 2004, T. 123: 6; the finds without preserved context in NMS include a bronze fibula with a long foot and a wire bow, which might once had an overlay that later fell off: *ibid.*, T. 125:13.

⁹⁶³ Haevernick 1959, 57 ff, T. 5, 6.

⁹⁶⁴ Stare V. 1978; Glunz 1997, Karte 13; Kruh 2008, 112, n. 240, Abb. 7.

⁹⁶⁵ Koch 2010.

⁹⁶⁶ *Ibid.*, 53, 196, Abb. 87, 276 f, Kat.-Nr. 180.

⁹⁶⁷ Tecco Hvala/Dular/Kocuvan 2004, 78, Abb. 39.

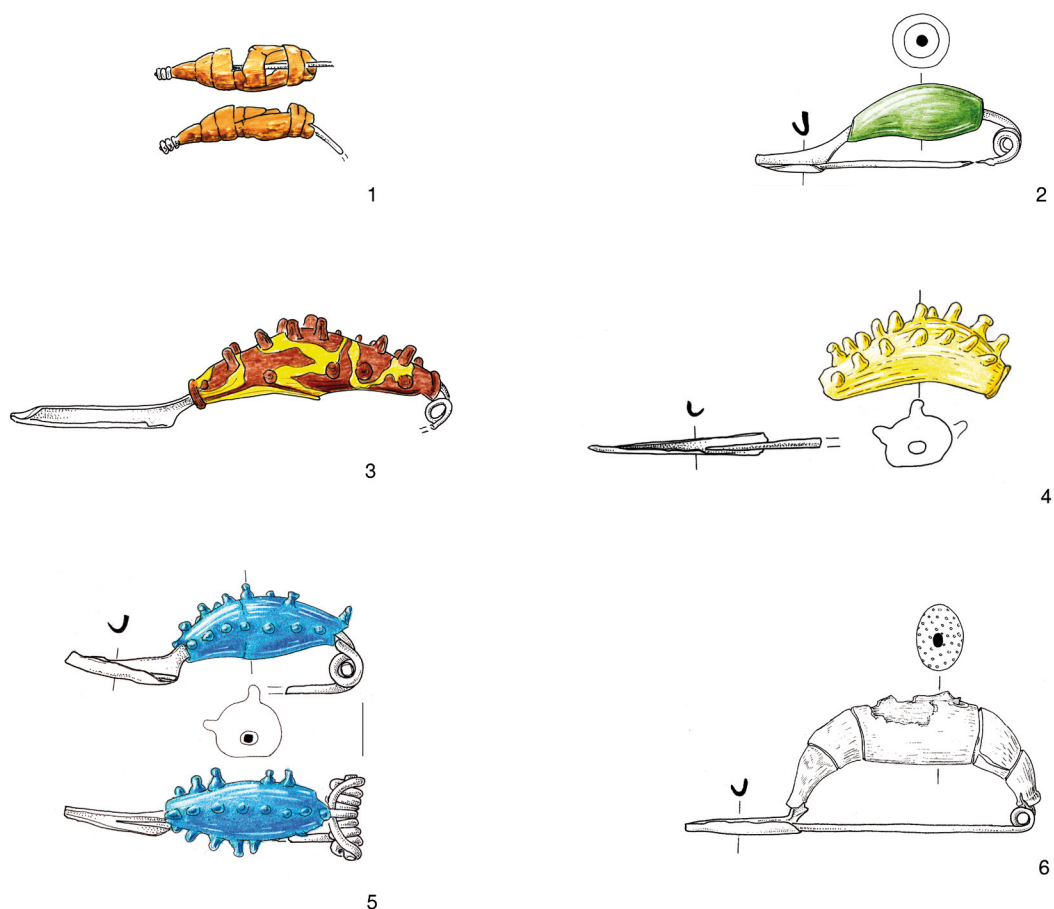

Sl. 86: Fibule z oblogo z Magdalenske gore. 1 = jantar; 2-5 = steklo; 6 = kost. M. = 1:2.

Fig. 86: Fibulae with a bow overlay from Magdalenska gora. 1 = amber; 2-5 = glass; 6 = bone. Scale = 1:2.
1, 3 – Preloge, gr. VII/40; 2 – Voselca, gr. 2/19; 4 – Preloge, gr. 2/h; 5 – Preloge, gr. 2/c; 6 – Preloge, gr. 13/163.

bile pritrjene. Obeska verjetno nista imela zgolj okrasne funkcije, ampak ju lahko razumemo kot apotropejsko znamenje, enako kot priložene živalske koščice. Po velikosti obročastega nakita pa bi lahko domnevali, da je bila v tem grobu pokopana deklica ali mladenka.

Pripadnico iz rodu gomile VII (grob VII/40) je krasilo menda sedem fibul s stekleno oblogo, "halštatska fibula z verižico in obeskom" ter še dve čolničasti fibuli. Imela je šest lepih bronastih vozlastih ovratnic, poleg njih nize jantarnih in steklenih jagod in štiri široke trakaste uhane. Na rokah je imela dva para zapestnic, na vsaki nogi po štirinajst nanožnic, k nogam so ji položili tudi pet vijčkov. Tri fibule jezevke imajo rjavo stekleno oblogo z rumenimi vložki (sl. 86: 3), tri so iz zelenega stekla, ena pa ima jantarno oblogo (sl. 86: 1). Viri in stanje v Peabodyjevem muzeju se v detajlih ne skladajo. Goldberg se je v noticah pritoževal, da je vojvodinja v mraku z veliko naglico pobirala najdbe, zato je nemara ostala nedokončana tudi skica prof. Torresa, ki prikazuje položaj predmetov v grobu. Torres je ob pokojničinah

of the pendant with a depiction of horned animals only the triangular plates with several elements of the chain are preserved. The pendants were probably more than mere adornments and also acted as apotropaic symbols similarly as the animal bones in the grave. The size of the ring jewellery in the grave indicates that either a girl or a young woman was buried.

The female member of the family buried in Tumulus VII (Grave VII/40) was reportedly adorned by seven fibulae with a glass overlay, "a Hallstatt fibula with a chain and pendant" and two boat fibulae. She had six beautiful knobbed torques of bronze, sets of amber and glass beads as well as four wide band earrings. On her arms were two pairs of bracelets and on each of her legs fourteen anklets. Five spindle whorls were laid at her feet. Of the fibulae with an overlay, three had a glass overlay made of brown glass with a yellow wavy line, transverse bands and spikes (fig. 86: 3), three of green glass and one had an amber overlay (fig. 86: 1). There are, however, minor inconsistencies between the sources and

nogah narisal otroško zapestnico in peščico steklenih jagod, medtem ko je Goldberg zapisal, da so bili ti predmeti najdeni skupaj z majhnima čolničastima fibulama ob pokojničini roki. Na podlagi te majhne zapestnice se domneva, da je bil z njo morda pokopan otrok, za kar ni drugih dokazov.⁹⁶⁸ Po zabelezkah je bil grob vkopan okoli pol metra v prvotno osnovo pod gomilo na jugozahodni strani in je bil zapolnjen z dolomitnim drobirjem. Okostje je ležalo v smeri sever–jug, z glavo na severu, in na leseni podlogi, kar bi se dalo sklepati po omenjeni tanki plasti počrnelega materiala.

Nič manj bogato nista bili opravljeni pripadnici rodu gomile 2, čeprav njuni pridatki niso ohranjeni v kompletu. Na prvo je Pečnik naletel 24. februarja 1893 na "zgornji strani" gomile in tri metre globoko. Opisal jo je kot 8 do 10 let staro deklco, ki je bila pokopana z glavo na jugu. Pri nogah je imela tri posode, med njimi lepo izdelano rdečo posodo, okrašeno s "svinčenimi" pasovi. Na nogah je imela po eno nanožnico, na rokah po dve zapestnici, ki so bile dobro ohranjene, na prsih dve fibuli – eno bronasto z moško figuro na dvokolesnem vozu s konjsko trovprego ter letečo ptico na koncu noge, drugo s stekleno oblogo modre barve (*sl.* 86: 5), zraven še eno majhno zlomljeno fibulo "redke vrste z okroglimi okraski", dva slabše ohranjena uhana; okoli vratu je imela jantarne in raznolike steklene jagode (ene so bile nasvitkane kot

⁹⁶⁸ Hencken 1978, 58 s, op. 11, Fig. 260.

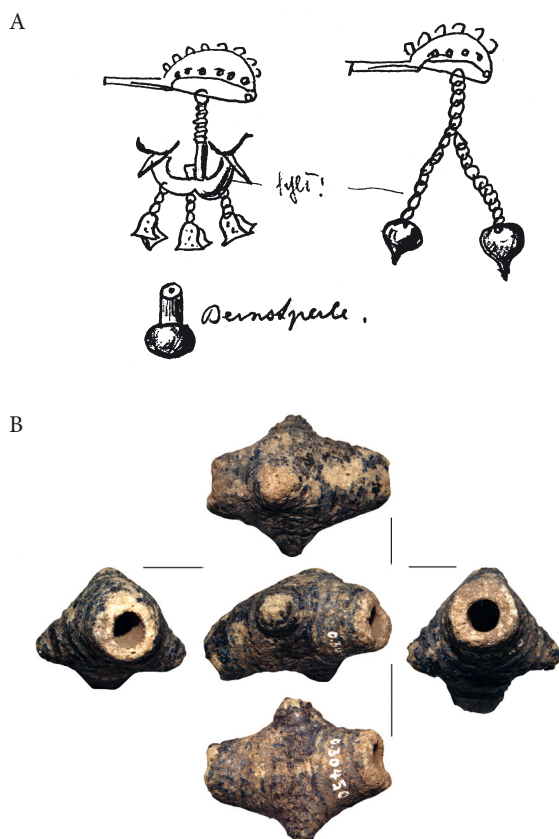

the inventoried state in the Peabody Museum. It is noted that Goldberg complained over the Duchess removing the finds in haste and at dusk, which might also be the reason why Professor Torres never finished his sketch of the position of goods in the grave. Torres drew a child's bracelet and some glass beads at the feet of the deceased, while Goldberg wrote that these objects had been found together with two small boat fibulae beside the arm. This small bracelet also gave rise to the supposition of a child being buried together with the woman, which is, however, not supported by other evidence.⁹⁶⁸ According to notes, the grave was dug roughly half a metre into the soil under the tumulus, on the south-western side, and filled with dolomite gravel. The skeleton had a north-south orientation, head to the north, and was laid onto wooden bedding; the latter being inferred from the thin layer of burnt material mentioned in the notes.

No less richly adorned were the two female members of the family from Tumulus 2, though their grave goods have not been completely preserved. The first of the graves Pečnik unearthed on 24 February 1893 on the "upper side" of the tumulus, three metres deep. He described the deceased as an 8 to 10-year-old girl buried with her head towards the south. She was buried with three vessels at her feet, among them a beautifully made red vessel, decorated with "lead" bands. She had an anklet on each of the legs, two well preserved bracelets on each of the arms and two fibulae on the chest. One of the fibulae had a male figure riding a two-wheeled chariot, pulled by three horses, and a bird in flight at the end of the foot. The other fibula had a blue glass overlay (*fig.* 86: 5). Beside the latter was a third fibula, small and broken, of a "rare type with round adornments", and two poorly preserved earrings. She had amber and various glass beads (some with spiral trails), as well as a sceptre.⁹⁶⁹ Pečnik found the second grave with this type of fibula in the same tumulus on 21 March 1893. The following day, this interesting find was reported by Črnologar to the Central Commission, while Pečnik informed the same institution at the end of the month. However, the information provided by Črnologar and Pečnik on the grave is inconsistent. It was found roughly four metres deep in the tumulus and contained a female skeleton laid

⁹⁶⁸ Hencken 1978, 58 f, n. 11, Fig. 260.

⁹⁶⁹ Tecco Hvala/Dular/Kocuvan 2004, 30, T. 10A.

Sl. 87: A – Brattinova skica fibul ježevk z obeski in jantarne jagode iz groba 13/163; B – obloga fibule domnevno z Magdalenske gore (po Koch).
Fig. 87: A – Brattina's sketch of the fibulae with a spiky glass overlay and pendants, as well as of an amber bead from Grave 13/163; B – overlay of a fibula supposedly from Magdalenska gora (after Koch).

vijaki) ter "žvenkljačo" oz. sceptor. Delno rekonstruirana grobna celota nosi oznako 2/c.⁹⁶⁹ Drugi grob s tako fibulo je odkril Pečnik v isti gomili dne 21. marca 1893. O zanimivem odkritju je Črnologar dan zatem poročal Centralni komisiji, medtem ko jo je Pečnik seznanil ob koncu meseca, kot je razvidno iz ohranjenih pisem. Njuni podatki o grobu se ujemajo. Približno štiri metre globoko v gomili so naleteli na žensko okostje v leseni krsti, z glavo obrnjeno proti jugu. Od glave do ledij je bilo prekrito z množico jantarnih in steklenih jagod, velikih kot orešček do čisto drobnih. Pokojnica je imela tudi mnogo brona-stega okrasja s finimi verižicami, ki je bilo zelo uničeno in ni ohranjeno, ter lepo fibulo z oblogo iz rumenega stekla, na nogah pa po eno masivno nanožnico in zraven tri rdeče posode. Od tega smo lahko identificirali le fibulo (sl. 86: 4), nanožnici in debele jantarne jagode; grob nosi našo oznako 2/h.⁹⁷⁰ En primerek z gladko oblogo brez izrastkov iz zelenega stekla (sl. 86: 2) je zabeležen še v okviru grobne celote 2/19 z Voselce, vendar Pečnikova zapisa o inventarju tega groba med seboj nista skladna in se ne ujemata s stanjem v inventarni knjigi dunajskega muzeja; v seznamu grobnih pridatkov Pečnik navaja štiri fibule, ki jih ni podrobneje opisal. Oblogo s tremi izrastki (sl. 87: B), ki jo objavlja Kochova, pa hrani Römisch-Germanisches Zentralmuseum, kamor naj bi prišla dozdevno leta 1939/40.⁹⁷¹

Razširjenost in časovni okvir. Na območju jugovzhodnih Alp je znanih nekaj desetih fibul s stekleno oblogo,⁹⁷² Magdalenska gora pa se z ducatom primerkov uvršča na prvo mesto med dolensjkimi najdišči. V Stični sta bili v otroškem grobu 5/27 najdeni fibuli z oblogo iz zelenega in iz modrega stekla skupaj z drobnima trortastima fibulama ter modrimi in rumenimi steklenimi jagodicami, medtem ko je znamenita stiška predstavnica z zlatim diademom in nakitom (48/27) nosila fibule s koščeno in jantarno oblogo. Zanimiv je kontekst iz Rovišča, v katerem se pojavljajo tri fibule s stekleno oblogo – dve modri z belimi spiralnimi linijami in ena rjava z belimi izrastki in spiralo. Najdene so bile skupaj z zlatimi lističi, stisnjenimi v nerazpoznavno obliko, z več kot tisoč jantarnimi jagodami ter z bronastim trirogelnim obeskom oz. sceptorom, na katerega so bile pritrjene verižice in paličasti členi s trikotnimi obeski ter pločevinastimi bobenčki. Večina okrasja,

⁹⁶⁹ Tecco Hvala/Dular/Kocuvan 2004, 30, T. 10A.

⁹⁷⁰ Ibid., 30 s.

⁹⁷¹ Egg/Pare 1995, 178, Nr. 11; Koch 2010, 196, 276 f, Abb. 87, Kat.-Nr. 180. Römisch-Germanisches Zentralmuseum v Mainz u menda hrani podobna primerka tudi iz Novega mesta (Koch 2010, 196).

⁹⁷² *Boštanj*: Guštin 1974b, T. 7: 2,3; *Brezje*: Kromer 1959a, T. 31: 8; *Libna*: Guštin 1976, T. 6: 7; Dular J. 2003, sl. 73; *Novo mesto*: Knez 1986, T. 13: 2; *Podzemelj*: Dular J. 1978, T. 2: 9; *Rovišče*: Stare V. 1962–1963, 139, sl. 2; Dular J. 2003, 244 s, sl. 138, T. 65: 10–12; *Stična*: Gabrovec et al. 2006, T. 127: 3,4; *Veliki Vinji vrh (Šmarjeta)*: Stare V. 1973a, T. 20: 23, 60: 6; Dular A. 1991, T. 47: 13; *Zagorica pri Čatežu*: Dular J. 2003, T. 39: 6.

into a wooden coffin with her head towards the south. It was covered, from head to waist, with numerous amber and glass beads, from the size of a nut to very small ones. The female also had numerous bronze adornments on fine chains, which were in very poor state and have not been preserved. She also had a beautiful fibula with an overlay of yellow glass, a solid anklet on each of her legs and three red vessels at her feet. Of the grave goods, we were able to identify the fibula (fig. 86: 4), two anklets and large amber beads; the grave is marked 2/h.⁹⁷⁰ A further fibula with an overlay, plain and made of green glass (fig. 86: 2), is recorded as part of Grave Group 2/19 from Voselca, though there is inconsistency in Pečnik's notes for this group, and further inconsistency between his notes and the inventory book of the museum in Vienna. Pečnik lists four fibulae without giving a detailed description. One fibula with a glass overlay with three protuberances (fig. 87: B), supposedly from Magdalenska gora, is also mentioned by Koch; the fibula is now kept in the Römisch-Germanisches Zentralmuseum, where it apparently arrived in 1939/40.⁹⁷¹

Distribution and time frame. The south-eastern Alps yielded several tens of fibulae with a glass overlay,⁹⁷² most numerous at Magdalenska gora. At Stična two fibulae with an overlay, of green and blue glass were found in child's Grave 5/27 together with two small three-knobbed fibulae as well as blue and yellow glass beads. The famous female from Stična with a gold diadem and other jewellery (48/27) wore fibulae with bone and amber overlays. An interesting grave was unearthed at Rovišče, containing three fibulae with a glass overlay. Two of the overlays were blue with white spirals and the third was brown with white spikes and a spiral. The fibulae were found together with gold leaves, compressed beyond recognition, over a thousand amber beads and a bronze three-pronged pendant or sceptre, attached to which were chains and small rod-shaped elements with triangular pendants and bronze sheet drums. Most of the adornments, bracelets and anklets as well, were wrapped in leather and the bundle placed between two wooden boards, possibly inside a small chest. This was reported by Schulz, who dug the tumulus in 1883 and sent the finds to Vienna. He also drew a sketch of the tumulus,

⁹⁷⁰ Ibid., 30 f.

⁹⁷¹ Egg/Pare 1995, 178, Nr. 11; Koch 2010, 196, 276 f, Abb. 87, Kat.-Nr. 180. Two similar examples reportedly from Novo mesto are also kept in the Römisch-Germanisches Zentralmuseum in Mainz (Koch 2010, 196).

⁹⁷² *Boštanj*: Guštin 1974b, T. 7: 2,3; *Brezje*: Kromer 1959a, T. 31: 8; *Libna*: Guštin 1976, T. 6: 7; Dular J. 2003, Abb. 73; *Novo mesto*: Knez 1986, T. 13: 2; *Podzemelj*: Dular J. 1978, T. 2: 9; *Rovišče*: Stare V. 1962–1963, 139, Abb. 2; Dular J. 2003, 244 f, Abb. 138, T. 65: 10–12; *Stična*: Gabrovec et al. 2006, T. 127: 3,4; *Veliki Vinji vrh (Šmarjeta)*: Stare V. 1973a, T. 20: 23, 60: 6; Dular A. 1991, T. 47: 13; *Zagorica pri Čatežu*: Dular J. 2003, T. 39: 6.

med njim zapestnice in nanožnice, je bilo omotanega v usnje, zavoj pa je bil položen med leseni deščici, morda v leseno skrinjico, kot poroča Schulz, ki je gomilo prekopal leta 1883 in najdbe poslal na Dunaj. Skiciral je tudi tloris gomile, v katerem je zabeležil lego 24 skupkov najdb. Iz te skice je v korelaciji z opisom moč ugotoviti, da so bili opisani predmeti najdeni v sredini gomile. Dular jih je objavil pod oznako skupek 1-1883/9, medtem ko jih je Staretova v objavi najdb s tega najdišča, ki jih hrani muzej v Ljubljani, označila za grob 8 v gomili 6. Fibulo ježevko z modro stekleno oblogo zasledimo tudi v bogati opravi predstavnice iz Libne, ki so jo odkrili leta 1962 v Špilerjevi gomili. Imela je še kačasto fibulo s pestiči, zlate triperesne lističe (diadem), ogrlice iz jantarnih in zlatih jagod, šest uhanov, dve zapestnici, štiri vijčke in osem posod. Skromnejše je bila opravljena pokojnica z Brezja, pokopana v grobu 7/33, ki je nosila majhno ježevko iz zelenega stekla skupaj s kačasto fibulo s krilci, jantarno in stekleno ogrlico, dve zapestnici in nanožnico. Iz Dolenjega Boštanja je delno ohranjena grobna celota, ki vsebuje dve fibuli z umetelno izdelanimi oblogama iz temnozelenega stekla z rumeno valovnico, zraven pa še zapestnico in ciborij z nagubanim ostenjem. V Novem mestu je podobna fibula zabeležena v dvojnem grobu 2/2 iz gomile na Znančevih njivah iz negovske stopnje.

V dolenjski halštatski sredini so znane tudi fibule s koščeno in jantarno oblogo.⁹⁷³ Na Magdalenski gori je v grobu 13/163 zabeležen primerek s koščeno oblogo (sl. 86: 6), v grobu VII/40 pa z jantarno oblogo (sl. 86: 1); oba sodita v stopnjo Stična.

Panorama opisanih dolenjskih grobov razkriva, da se fibule z oblogo pojavljajo v ženskih in deklinjskih grobovih iz stopnje Stična 2, pa tudi kasneje. Zlato okrasje, scepri in drugi pridatki apotropijskega značaja v teh opravah pričajo o posebnem statusu njihovih nosilk v dolenjski halštatski družbi in spominjajo na izstopajoče ženske in deklinjske oprave iz obdobja *orientalizante* na Apeninskem polotoku.⁹⁷⁴ Stike s tem prostorom izpričuje obloga fibule z Magdalenske gore v muzeju v Mainzu, ki ima najboljše analogije v Gazzo Veronese in v Verucchio, v grobu Lippi 1972/13 iz prve polovice 7. st. pr. n. št.⁹⁷⁵ Primerki fibul ježevk iz groba 1-1883/9 v Rovišču pa imajo najboljšo paralelo v najdbi iz groba Este-Casa Alfonsi 22, ki je datiran v Este IIID1 po Peroniju (= stopnja certoških fibul na Dolenjskem).⁹⁷⁶

noting the position of 24 sets of finds. The sketch in correlation with the description allows us to establish that the above-listed objects were found in the centre of the tumulus. Dular published them as Set 1-1883/9, while Stare marked them as Grave 8 from Tumulus 6 in the publication of the finds from the site kept in the museum in Ljubljana. Another fibula with a blue glass overlay with spikes formed part of the rich costume of a female buried at Libna, unearthed in 1962 in the Špiler tumulus. Besides the fibula with an overlay, the female also had a serpentine fibula with antennae, gold three-lobed leaves (diadem), necklaces of amber and gold beads, six earrings, two bracelets, four spindle whorls and eight vessels. The costume of the female buried in Grave 7/33 at Brezje was less rich. It consisted of a small fibula with a green glass overlay with spikes, a serpentine fibula with wings, an amber and glass necklace, two bracelets and an anklet. The partly preserved grave group from Dolenji Boštanj consisted of two fibulae with a skilfully made overlay of dark green glass with a yellow wavy line, a bracelet and a footed bowl with indented walls. A similar fibula was documented at Novo mesto, in double Grave 2/2 from the Negova-phase tumulus at Znančeve njive.

The Dolenjska community also knew fibulae with either a bone or amber overlay.⁹⁷³ Both were documented at Magdalenska gora, the bone example in Grave 13/163 (fig. 86: 6) and the amber in Grave VII/40 (fig. 86: 1). They date to the Stična phase. The fibulae with an overlay appear in graves of either women or girls from the Stična phase, but also later. The accompanying gold adornments, sceptres and other items of apotropaic character indicate a special status of their owners and are reminiscent of the exceptional women's and girl's costume from the *Orientalizante* period on the Apennine Peninsula.⁹⁷⁴ Connections between the two regions are further indicated by the overlay of the fibula from Magdalenska gora kept in Mainz, which has closest analogies at Gazzo Veronese and Verucchio-Grave Lippi 1972/13 from the first half of the seventh century BC.⁹⁷⁵ Moreover, the fibulae with a spiky overlay from Rovišče, have the closest parallel in Grave Este-Casa Alfonsi 22 dated to Este IIID1 after Peroni (= Certosa phase in Dolenjska).⁹⁷⁶

⁹⁷³ Rovišče: Stare V. 1962–1963, T. 5: 6; Stična: Gabrovec et al. 2006, T. 18: 18,19,23, 174: 42; Vače: Stare F. 1955a, T. 34: 1; Veliki Vinji vrh (Šmarjeta): Dular A. 1991, T. 46: 11. Glej še Palavestra 1993, 223: tip 75.

⁹⁷⁴ Negroni Catacchio 2007; Fig. 7, 10, 12, 19, 26–29; Koch 2010, 87 ss.

⁹⁷⁵ Koch 2010, 53, 122 ss, Abb. 53, 288 s, Kat. Nr. 98+99; Gentili 2003, T. 87: 45. "Ježevkam" je podoben še primerek iz groba 47 v Verucchio (Gentili 2003, T. 111: 48a, CCXIV: 48a).

⁹⁷⁶ Chieco Bianchi/Calzavara Capuis 1985, 406, 456, T. 273B: 4.

⁹⁷³ Rovišče: Stare V. 1962–1963, T. 5: 6; Stična: Gabrovec et al. 2006, T. 18: 18,19,23, 174: 42; Vače: Stare F. 1955a, T. 34: 1; Veliki Vinji vrh (Šmarjeta): Dular A. 1991, T. 46: 11. See also Palavestra 1993, 223: Type 75.

⁹⁷⁴ Negroni Catacchio 2007; Figs. 7, 10, 12, 19, 26–29; Koch 2010, 87 ff.

⁹⁷⁵ Koch 2010, 53, 122 ff, Abb. 53, 288 f, Kat. Nr. 98+99; Gentili 2003, T. 87: 45. Similar to the Dolenjska type of fibulae with a spiky glass overlay is an example from Grave 47 at Verucchio (Gentili 2003, T. 111: 48a, CCXIV: 48a).

⁹⁷⁶ Chieco Bianchi/Calzavara Capuis 1985, 406, 456, T. 273B: 4.

4.7.6 KAČASTE FIBULE

Magdalenska gora ponuja tudi dober vpogled v oblikovni spekter kačastih fibul, ki se pojavljajo v jugovzhodnoalpskem svetu. V okviru raznih študij jih je obravnavala že Biba Teržan in izpostavila njihov kronološki pomen. Za različne oblike tovrstnih fibul so v rabi opisne oznake (npr. kačaste fibule s pestiči, z dvema zankama, z valovitim lokom, s ploščicama, s krilci itd.),⁹⁷⁷ nekateri tipi so poimenovani po najdiščih, kot npr. tip Vače-Uffing (po Kossacku) ali tip Tržišče (po Guštinu), za nekatere druge se uporabljajo oznake, kot npr. S4, S5 po klasifikaciji, ki jo je predložil Mansfeld.⁹⁷⁸ Na Mansfeldovo nomenklaturu se je oprl tudi Parzinger, ki je primerke iz dolenskega prostora označil kot južnoalpske različice.⁹⁷⁹ Z njimi se je nazadnje ukvarjala Alexia Nascimbene in jih razdelila v tri tipe I.1 do I.3 z različnimi variantami.⁹⁸⁰ Na tem mestu bom zaradi enotnejšega in enostavnejšega prikaza v razpredelnicah uporabljala svoje delovne oznake.

Tipološke značilnosti. Najpreprosteje je bila izdelana fibula z žičnatim lokom, ki je sedlasto oblikovan z enim kolenom ter dvema zankama, noga je ploščato razkovan in se zaključuje z gumbkom (sl. 88: 8).⁹⁸¹ Zanj tukaj uporabljam oznako tip I.

Dokaj enostavno so bile izdelane tudi fibule z valovitim lokom, ki bi jih lahko delili na dve različici. Različica **Ia** ima žičnat lok okroglega preseka, ki prehaja prek dvojne peresovine v iglo, drugi konec pa je ploščato razkovan v ležišče za iglo (sl. 88: 9), medtem ko ima različica **Ib** trakast lok in disk namesto zanke na prehodu v iglo (sl. 88: 10). Noga pri teh fibulah nima posebej izoblikovanega zaključka.⁹⁸²

Izdelava kačastih fibul s pestiči je bila precej bolj zahtevna. Lok je sedlasto oblikovan z dvema kolenoma; par pestičev je z enim kolenom zlit, drugi par pa je bil posebej izdelan in z zakovico pritrjen na drugo koleno, ki ima zato luknjico (sl. 88: 2–4). Pestiči upodabljajo makove glavice na pecljih ter rozete ali kolesca, v čemer je moč prepoznati orientalizirajoče vplive. Noga s presekom v obliki črke J se zaključuje z enim ali več gumbki, na prehodu iz loka v iglo pa je postavljen disk. Lepši primerki imajo na loku še razne figurice ptic ali rac ter vrezan okras, drugi so enostavnejši.⁹⁸³

⁹⁷⁷ Lunz 1974, 134: e, 139: u; Teržan/Trampuž 1973, 427; Teržan/Lo Schiavo/Trampuž-Orel 1985, 24 s; Teržan 1990a, karta 20; ead. 1987, 22, Fig. 12.

⁹⁷⁸ Kossack 1959, T. 155B; Guštin 1973, karta 3, op. 51; Mansfeld 1973, 5 ss, 107 ss, 153 ss.

⁹⁷⁹ Parzinger 1988, Taf. 143.

⁹⁸⁰ Nascimbene 2009, 69 ss.

⁹⁸¹ Tecco Hvala/Dular/Kocuvan 2004, T. 121A: 1.

⁹⁸² Hencken 1978, Fig. 249, 252c.

⁹⁸³ Hencken 1978, Fig. 354c; Tecco Hvala/Dular/Kocuvan 2004, sl. 43, T. 121B: 3, 143A: 2,3, 152: 16.

4.7.6 SERPENTINE FIBULAE

Magdalenska gora offers a good insight into the formal spectre of serpentine fibulae (*Schlangenfibeln*) found in the south-eastern Alpine region. They were discussed in numerous studies by Biba Teržan, who also showed their chronological significance. The various types of these fibulae bear descriptive names (for example serpentine fibulae with antennae, with two loops, with a wavy bow, with plates, with wings and others),⁹⁷⁷ some variants are named after sites, for example Type Vače-Uffing (after Kossack) or Type Tržišče (after Guštin), while others use a code such as S4 or S5 after the classification proposed by Mansfeld.⁹⁷⁸ The latter nomenclature was taken as basis by Parzinger, who determined the examples from Dolenska as Southern Alpine variants (*Südalpine Schlangenfibeln* S4).⁹⁷⁹ The last to study serpentine fibulae was Alexia Nascimbene, who divided them into three types, from I.1 to I.3, with variants.⁹⁸⁰ For the sake of uniformity and simplicity, I use my own, working names for the various types in this publication.

Typological characteristics. The simplest serpentine fibulae are those with a wire bow, which is saddle-shaped with one elbow and two loops (*Zweischleifige Schlangenfibeln*); their foot is flattened and terminates in a knob (fig. 88: 8).⁹⁸¹ These fibulae are marked as Type I.

Of a fairly simple make were also the fibulae with a wavy bow (*Drahtfibeln mit gewelltem Bügel*), which could be subdivided into two variants. Variant **Ia** has a wire bow of a round section that continues, via a two-coil spring, into the pin. The other end of the wire is flattened into the catch-plate (fig. 88: 9). Variant **Ib** has a band bow and a disc guard rather than a coil spring at the bow-to-pin transition (fig. 88: 10). The foot in both variants is without a terminal.⁹⁸²

Making serpentine fibulae with antennae (*Hörnchen-/Dragofibeln*) was much more complicated. The bow was saddle-shaped with two elbows. One pair of antennae was cast together with one elbow, while the other pair was separately made and attached to the second elbow with a rivet. The other elbow thus has a rivet hole (fig. 88: 2–4). The antennae take the form of either poppy heads on stems, rosettes or small wheels, which reveals orientalisising influences. The J-shaped foot terminates in one or more knobs, while a disc guard is placed at the bow-to-pin transition. More ornate examples also have

⁹⁷⁷ Lunz 1974, 134: e, 139: u; Teržan/Trampuž 1973, 427; Teržan/Lo Schiavo/Trampuž-Orel 1985, 24 f; Teržan 1990a, map 20; ead. 1987, 22, Fig. 12.

⁹⁷⁸ Kossack 1959, T. 155B; Guštin 1973, Cart. 3, n. 51; Mansfeld 1973, 5 ff, 107 ff, 153 ff.

⁹⁷⁹ Parzinger 1988, Taf. 143.

⁹⁸⁰ Nascimbene 2009, 69 ff.

⁹⁸¹ Tecco Hvala/Dular/Kocuvan 2004, T. 121A: 1.

⁹⁸² Hencken 1978, Figs. 249, 252c.

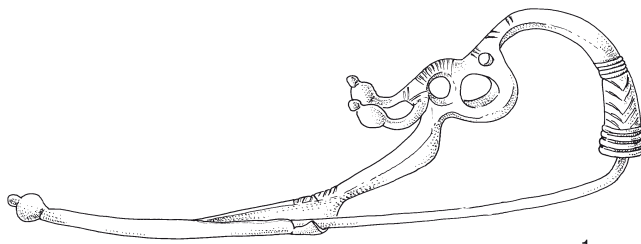

1

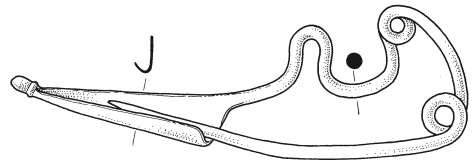

8

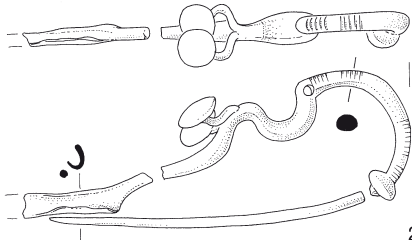

2

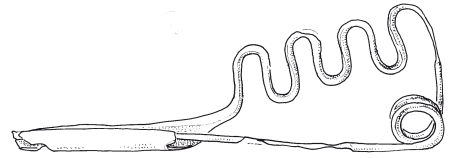

9

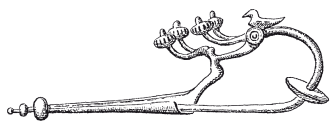

3

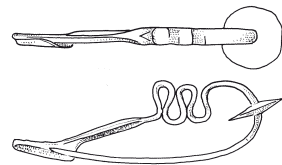

10

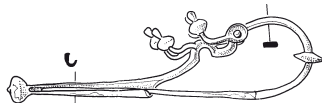

4



11

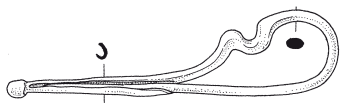

5



12

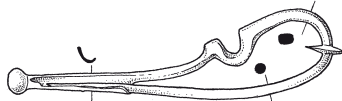

6

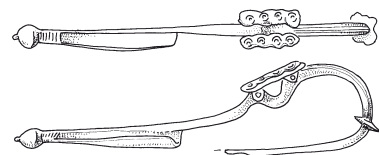

13

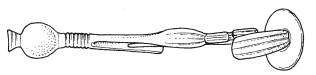

7



14

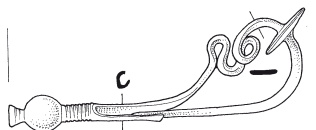

7

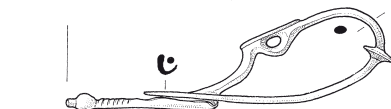

14

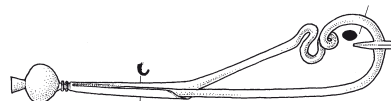

15

Za tovrstne fibule, ki so izdelane iz dveh ali več kosov, uporabljamo oznako različica **IIIa**, ki jo je možno po velikosti in raznih detajlih še podrobneje deliti. Kot različico **IIIb** označujem velike fibule iz enega kosa (sl. 88: 1),⁹⁸⁴ ki imajo namesto sedlastega loka zlito zanko ter trombasto ali kako drugače oblikovan prehod v iglo (= tip Vače-Uffing po Kossacku in lokalna varianta tip Tržišče po Guštinu).

Enostavno, minimalistično obliko predstavljajo fibule s sedlastim lokom brez diska, tj. različica **IVa** (sl. 88: 5),⁹⁸⁵ od katere se varianta **IVb** razlikuje edino po tem, da ima disk na prehodu v iglo (sl. 88: 6).⁹⁸⁶ Nascimbene je jih označuje kot tip I.1 s štirimi variantami (A–D) in domneva, da je bil disk pri različici brez njega morda posebej nataktnjen na lok in da je odpadel.⁹⁸⁷

Fibule s krilci bi v tipološkem smislu lahko predstavljale nadgradnjo tipa IV ter poenostavljeno izvedbo tipa III. Tip V ima krilci posebej izdelani in pritrjeni z zakovico, ki je vdeta v luknjico na enem kolenu loka, drugi konec krilca pa je prost; na prehodu loka v iglo imajo zmeraj disk (sl. 88: 11).⁹⁸⁸ Nascimbene je jih opredeljuje kot tip I.2 in jih podrobneje deli na dve varianti (A in B) s podvariantama (A1 in A2) glede na dodatne okrasne elemente ter oblikovanost diska.⁹⁸⁹

Pri fibulah s ploščico sta opazna dva načina izdelave. Pri različicah **VIa** in **VIb** sta ploščici posebej izdelani in pritrjeni na lok z dvema zakovicama, ki sta vdeti skozi luknjici na obeh kolenih (sl. 88: 12, 13), medtem ko je pri različici **VIc** ploščica zlita s kolenoma (sl. 88: 14). Ploščice so lahko podobno razčlenjene kot krilca pri tipu V ali pa je zgornja ploskev okrašena s koncentričnimi krožci.⁹⁹⁰ Različica VIa ustreza varianti I.3B po Nascimbenevi, različica VIb pa njeni varianti I.3A, medtem ko tretje variante z zlito ploščico ne obravnava.⁹⁹¹

⁹⁸⁴ Hencken 1978, Fig. 11.

⁹⁸⁵ Hencken 1978, Fig. 38b, 48d, 75d, 318b, 334m,n; Tecco Hvala/Dular/Kocuvan 2004, T. 28B: 2, 62B: 5, 90E: 2, 132A: 1.

⁹⁸⁶ Hencken 1978, Fig. 13a,b, 49d, 62a, 66a, 82l, 86l, 90a, 133b, 154d, 172d, 258c, 313a, 322k, 326a, 330b, 345d; Tecco Hvala/Dular/Kocuvan 2004, T. 48B: 9, 134D: 6, 152: 14.

⁹⁸⁷ Nascimbene 2009, 69 ss, Fig. 12.

⁹⁸⁸ Hencken 1978, Fig. 15a, 72b, 127e, 345c, 348a, 352h, 353a, 357b, 359u; Tecco Hvala/Dular/Kocuvan 2004, T. 51: 7, 95B: 11.

⁹⁸⁹ Nascimbene 2009, 75 ss, Fig. 14.

⁹⁹⁰ Hencken 1978, Fig. 31b, 72c, 74, 78c; Tecco Hvala/Dular/Kocuvan 2004, T. 78B: 2, 138: 18, 152: 17-19.

⁹⁹¹ Nascimbene 2009, 87 ss, Fig. 17.

various bird or duck figures as well as incised decoration on the bow.⁹⁸³ The fibulae composed of two or more pieces are marked as Variant **IIIa**, which may be further divided according to various sizes and details. Variant **IIIb** marks large fibulae of one piece (fig. 88: 1)⁹⁸⁴ with a cast loop and a trumpet- or otherwise shaped bow-to-pin transition (= Type Vače-Uffing after Kossack, a local variant or Type Tržišče after Guštin).

The fibulae with a saddle-shaped bow without the disc guard show a simple, minimalist form and are marked as Variant **IVa** (fig. 88: 5).⁹⁸⁵ Variant **IVb** differs from it only in the presence of a disc guard (fig. 88: 6).⁹⁸⁶ Nascimbene marked them as Type I.1 with four variants (A–D) and supposes that the disc guard, in the version without it, may have been separately attached and later fell off.⁹⁸⁷

Fibulae with wings could represent a typologically upgraded Type IV, but also a simplified Type III. Fibulae with wings are marked as Type V. It has two separately made wings attached to the bow with a rivet. The latter is placed on one of the elbows of the bow (fig. 88: 11).⁹⁸⁸ Nascimbene marked them as Type I.2, subdivided into Variants A and B, with subvariants A1 and A2, depending on the additional decorative elements and form of the disc guard.⁹⁸⁹

The fibulae with plates are marked as Type VI and show two different manners of production. Plates in Variants **VIa** and **VIb** are separately made and fixed to the bow with two rivets on both elbows (fig. 88: 12, 13). The plate on Variant **VIc** is cast together with the elbows (fig. 88: 14). Plates can be similarly shaped as the wings in Type V, but can also have the upper surface decorated with concentric circles.⁹⁹⁰ Variant VIa corresponds to Variant I.3B after Nascimbene, Variant VIb corresponds

⁹⁸³ Hencken 1978, Fig. 354c; Tecco Hvala/Dular/Kocuvan 2004, Abb. 43, T. 121B: 3, 143A: 2,3, 152: 16.

⁹⁸⁴ Hencken 1978, Fig. 11.

⁹⁸⁵ Hencken 1978, Figs. 38b, 48d, 75d, 318b, 334m,n; Tecco Hvala/Dular/Kocuvan 2004, T. 28B: 2, 62B: 5, 90E: 2, 132A: 1.

⁹⁸⁶ Hencken 1978, Figs. 13a,b, 49d, 62a, 66a, 82l, 86l, 90a, 133b, 154d, 172d, 258c, 313a, 322k, 326a, 330b, 345d; Tecco Hvala/Dular/Kocuvan 2004, T. 48B: 9, 134D: 6, 152: 14.

⁹⁸⁷ Nascimbene 2009, 69 ff, Fig. 12.

⁹⁸⁸ Hencken 1978, Figs. 15a, 72b, 127e, 345c, 348a, 352h, 353a, 357b, 359u; Tecco Hvala/Dular/Kocuvan 2004, T. 51: 7, 95B: 11.

⁹⁸⁹ Nascimbene 2009, 75 ff, Fig. 14.

⁹⁹⁰ Hencken 1978, Figs. 31b, 72c, 74, 78c; Tecco Hvala/Dular/Kocuvan 2004, T. 78B: 2, 138: 18, 152: 17-19.

Sl. 88: Tipi kačastih fibul z Magdalenske gore. M. = 1:2.

Fig. 88: Types of serpentine fibulae from Magdalenska gora. Scale = 1:2.

1 – Preloge, Tum. II (**IIIb**); 2 – Preloge, gr. 13/161 (**IIIa**); 3, 4 – Voseleca, gr. 6/1 (**IIIa**); 5 – Preloge, gr. 2/19 (**IVa**); 6 – Preloge, gr. 2/54 (**IVb**); 7 – Preloge, gr. 2/46 (**VIIb**); 8 – Preloge, gr. 13/158 (**I**); 9 – Preloge, gr. VII/32 (**IIa**); 10 – Preloge, gr. VII/29 (**IIb**); 11 – Voseleca, gr. 2/12 (**V**); 12 – Preloge, gr. IV/32 (**VIa**); 13 – Preloge, Tum. II (**VIb**); 14 – Preloge, gr. 13/41 (**VIc**); 15 – Voseleca, gr. 2/7 (**VIIa**).

Pri kačastih fibulah, ki jih označujem kot tip **VII**, ima različica **VIIa** žičnat lok zvit v koleno in zanko, na prehodu v iglo pa disk ter na koncu noge gumbek (*sl. 88: 15*).⁹⁹² Pri različici **VIIb** je lok trakasto razširjen in včasih ornamentiran z vzdolžnimi vrezi, velik disk je lahko posebej natakjen in tudi bolj umetelno oblikovan, noga je masivnejša in ima na koncu kroglast zaključek s čepkom (*sl. 88: 7*).⁹⁹³

Lega in kontekst. Na Magdalenski gori lahko naštejemo 74 primerkov kačastih fibul različnih oblik. Evidentirane so v 57 grobnih celotah, vendar niso vse zanesljive, zlasti ne tiste, ki so bile odkrite v zgodnejših akcijah vojvodinje Mecklenburške. Največ grobov s kačastimi fibulami je zabeleženih v gomilah na Prelogah – štirinajst grobov v gomili X na Prelogah, dvanajst grobov v gomili IV, sedem grobov v gomili 13 ter šest grobov v gomili 2 in le en grob v gomili VI. Manj grobnih celot s kačastimi fibulami je znanih z Laščika ter z Voselce.

Kačasta fibula z dvema zankama (tip **I**) je edina te vrste na Magdalenski gori (*sl. 88: 8*), pripada pa skupaj z dvema uhanoma iz spiralno zvite žice inventarju žarnega groba 13/158.

Edinstvena sta tudi primerka fibul tipa **II** z valovitim lokom, ki izvirata iz gomile VII. Različica **IIa** (*sl. 88: 9*) je objavljena v sklopu pridatkov žarnega groba VII/32 s Prelog, skupaj z bronasto dvozankasto vozlasto fibulo 6a po Gabrovcu, medtem ko naj bi različica **IIb** (*sl. 88: 10*) predstavljala edini pridelek v skeletnem grobu VII/29, kjer je ležala ob lobanji.

Fibule s pestiči različice **IIIa** zasledimo v žarnem grobu (Voselca, gr. 6/1), pa tudi v skeletnih grobovih (Preloge, gr. X/70, 13/161). Pripadale so ženskim in moškim opravam (*sl. 89*), kar je novost v primerjavi s starejšimi tipi fibul, ki so jih nosile samo ženske in deklice. Grobno celoto 6/1 z Voselce smo lahko delno rekonstruirali na podlagi Dežmanove notice in risbe najlepše med tremi takimi fibulami, ki so bile položene v estensko glinasto situlo, pokrito z bronastim krožnikom (*sl. 88: 3, 4 in sl. 24*). Tudi grob 13/95 predstavlja žgani pokop v žaro, v kateri so bili sežgani ostanki bronaste situle, železen nož in obroč ter bronast zatič. Brattina med pridatki omenja še "2 vom Feuer nicht berührte Schlangenfibel mit Rädchen verziert" (kačasti fibuli z rozetami?), ki sta izgubljeni, vendar bi ju po opisu sodeč lahko pripisali temu tipu. V isti gomili je bila taka fibula najdena v skeletnem grobu 13/161 (*sl. 88: 2*) z jantarno ogrlico in trakastim uhanom iz trakaste žice z vzdolžno kaneluro and presegajočima koncema. Slabše je ohranjen primerek, ki je evidentiran v sklopu grobne celote X/70 s Prelog skupaj z železno rombično pasno spono in železnim nožem. O grobu II/1a, v katerem je objavljena fibula različice **IIIb** (*sl. 88: 1*), pa ni nič znanega.

⁹⁹² Tecco Hvala/Dular/Kocuvan 2004, T. 132C: 1.

⁹⁹³ Hencken 1978, Fig. 8a, 84g, 86 l, 300i; Tecco Hvala/Dular/Kocuvan 2004, T. 41: 2,3, 57A: 2, 118: 8, 152: 15.

to her Variant I.3A, while she does not discuss the third variant with the plate cast together with the elbows.⁹⁹¹

Serpentine fibulae marked as Type **VII** come in two variants. Variant **VIIa** has a wire bow curved into an elbow and a loop, a disc guard and a small knob at the end of the foot (*fig. 88: 15*).⁹⁹² Variant **VIIb** has the bow widened into a band and sometimes decorated with longitudinal incisions. The disc guard is large, separately attached and also more ornate. The foot is massive and has a spherical terminal with a projection (*fig. 88: 7*).⁹⁹³

Position and context. Magdalenska gora yielded altogether 74 examples of serpentine fibulae of various types and variants. They were documented in 57 grave groups, not all of which are reliable, particularly not those found in the early excavations by the Duchess of Mecklenburg. Most graves with serpentine fibulae are recorded in tumuli at Preloge; fourteen graves in Tumulus X, twelve in Tumulus IV, seven in Tumulus 13, six in Tumulus 2 and one in Tumulus VI. Less grave groups with serpentine fibulae are known from Lašcik and Voselca.

Magdalenska gora yielded a single serpentine fibula with two loops of Type **I** (*fig. 88: 8*). It was found in urn Grave 13/158 together with two earrings of spiral wire.

Of Type **II** with a wavy bow, two were found in Tumulus VII. The fibula of Variant **IIa** (*fig. 88: 9*) is published as part of the goods in urn Grave VII/32 from Preloge, together with a two-looped knobbed fibula of Type 6a after Gabrovec. The fibula of Variant **IIb** (*fig. 88: 10*) supposedly represented the only good in inhumation Grave VII/29, found beside the skull.

Fibulae with antennae of Variant **IIIa** were found in one urn (Voselca, Gr. 6/1) and in inhumation graves (Preloge, Gr. X/70, 13/161). They formed parts of both the female and male costume (*fig. 89*), which is a novelty in comparison with earlier types worn by women and girls only. We were able to partially reconstruct Grave Group 6/1 from Voselca on the basis of Dežman's note and drawing of the most beautiful among the fibulae, which were laid into an Este clay situla covered with a bronze plate (*fig. 88: 3, 4 and fig. 24*). Grave 13/95 also represents a cremation burial in an urn, which further contained burnt remains of a bronze situla, iron knife and ring as well as a bronze toggle. Of its goods, Brattina also mentions "2 vom Feuer nicht berührte Schlangenfibel mit Rädchen verziert" (serpentine fibulae with small wheels?), which are now lost, but may be ascribed to Type **IIIa** on the basis of the description. Another such fibula was found in the same tumulus in inhumation Grave 13/161 (*fig. 88: 2*) together with an amber necklace and an earring of flat wire with a longitudinal groove and overlapping ends. Less well preserved is the example from Grave Group X/70

⁹⁹¹ Nascimbene 2009, 87 ff, Fig. 17.

⁹⁹² Tecco Hvala/Dular/Kocuvan 2004, T. 132C: 1.

⁹⁹³ Hencken 1978, Figs. 8a, 84g, 86 l, 300i; Tecco Hvala/Dular/Kocuvan 2004, T. 41: 2,3, 57A: 2, 118: 8, 152: 15.

Gom. / gr. Tum. / gr.	Pokop / Burial rite	Spol / starost Sex / Age	Tipi fibul / Types of fibulae	Št. fibul / No. of fibulae	Igla / Pins	Uhani / Earrings	Ovratnice / Torques	Steklene jagode / Glass beads	Jantar / Amber	Au nakit / Au jewellery	Zapestnice / Bracelets	Scepter / Sceptre	Pasne sponje / Belts	Čelada / Helmet	Sekire / Axes	Sulice / Spears	Noži / Knives	Zatič / Toggle	Lončarina / Pottery	Koščen tul / Bone tube	Bronasto posodje / Bronze vessels	Vijčki / Spindle whorls	Šivanka / Needle		
P 13/158	C	F	I	1		2													1						
P VII/32	C	F	IIa	1+1*															2						
P VII/29	S	F?	IIb	1																					
P 13/161	S	F	IIIa	1		2			x																
V 6/1	C	F	IIIa	3			2	x	x		2								1		1				
P 13/95	C	M	IIIa?	2													1	1	2		1				
P X/70	S	M	IIIa?	1									Fe				1								
P 2/19	?	F	IVa	1					x		2														
P 2/81	S	I		1+1*	1			2	1		2														
P IV/2	?	F		1		4					2														
P X/26	S	F		1		4		x																	
P 13/73	S	F		1		1																			
P X/43	C	F		1+1*		6														2				1	
V 2/4	C	F?		1																2					
P VII/39	S	M		IVb	1									1	1	1	2	1							
L V/27	S	M			1												1								
P IV/13	?	?			1																				
P X/38	S	F	1			1					2									1					
P X/34-35	S	F+F	1							x		2													
P X/22	S	F	1							x		2													
L V/34	S	F	1							x		2													
P IV/27	?	F	1							x															
P VI/1	?	I?	1					2		x															
P IV/49	?	F	1			2																			
P 2/54	S	F	1			2		1	x																
P IV/41	?	F	1+1*			2+4?				x										1					
V 2/12	S	I	IVb+V		1+1		2	1	x												1		1		
P X/67	S	I	V?		1+1*	1			x			2													
P X/72	S	F	V		1+1*		4			x	x	2+2													
P X/75	S	F		1		1	4		x	x		2	1												
P 13/88	S	F		1		4		2	3			2								1					
P X/61	S	F		1		3				x															
P X/69	S	M?		1														1		2					
P 2/57	S	M		2										2	1	1	2	1		4		3			
P IV/37	S	M?		VIb	1	1												1							
P IV/33	S	F		VIc	1		2			x															
P 13/41	S	F		VIc	1				2																
V 2/7	?	I		VIIa	1			1				2								3					
P 13/152	S	F	VIIIb	1		2		x	x		2	1							5						
P X/4	S	F		1		1			x	x										4			1		
P 2/46	S	M		2										1		1	2			3		3			
P 2/62	S	M		2										1						1					

Sl. 89: Struktura pridatkov v grobovih s kačastimi fibulami na Magdalenski gori. * = drugačen tip.
Fig. 89: Structure of goods in the graves with serpentine fibulae at Magdalenska gora. * = other type.

Najbolj razširjene so bile kačaste fibule enostavnih oblik, ki jih označujem za različici **IVa** in **IVb** (sl. 88: 5, 6). Nosile so jih ženske, otroci in tudi moški (sl. 89). Različica IVa je v dveh primerih zabeležena v žganih grobovih – v grobu 2/4 z Voselce kot edini pridatek v žari, medtem ko je grob X/43 s Preloge vseboval po Goldbergovih navedbah kačasto fibulo, na kateri je viselo šest uhanov, ter eno ločno fibulo, bronasto šivanko in dve posodi, kar se ne ujema z objavljeno grobno celoto, ki predstavlja poleg dveh kačastih fibul različice IVa še samostrelni certoški fibuli vrste XIII, osem trakastih uhanov in dve šivanki. Različico IVb zasledimo v grobu poglavarja iz gomile VII na Prelogah, ki je med drugim imel dvogrebenasto čelado (VII/39), kačasta fibula pa naj bi ležala v bližini pokojnikovega vratu. Drugi moški s tako fibulo je bil skromneje opremljen (Laščik, gr. V/27). Iz preglednice (sl. 89) je razvidno, da so ženske običajno nosile po eno tako fibulo v kombinaciji z uhani iz trakaste žice ali s širokimi trakastimi uhani s kvačico ter dvema masivnima narebrenima zapestnicama. Oprave, v katerih nastopa različica IVb, so obogatene z ogrlicami iz debelih jantarnih jagod (steklene jagode so redke in praviloma modre barve ali prozorne). V nekaterih primerih zasledimo lasno iglo z uvito ali s kroglasto glavico ter vozlasti ovratnici. Srečamo jih tudi v kombinaciji z drugimi fibulami – drobno ločno fibulo (otroški grob 2/81 s Preloge) ali s kačasto fibulo s krilci (otroški grob 2/12 z Voselce), medtem ko je v kontekstu X/43 omenjena ločna fibula, v sestavu IV/41 pa "zahodnohalštatska" fibula.

Bogatejše so bile oprave s kačastimi fibulami s krilci tipa **V** (sl. 88: 11 in sl. 89), ki so vsebovale po štiri valjaste uhane, jantarne in steklene ogrlice, iglo s kroglasto glavico, po dve masivni narebreni zapestnici in tudi votli narokvici, pa zlato folijo ali scepter. V grobu X/72 jo zasledimo v kombinaciji s čolničasto fibulo variante 3b po Jerinovi, v otroškem grobu X/67 pa s certoško fibulo vrste I po Teržanovi. Par takih fibul je nosil tudi lastnik dvogrebenaste čelade, pokopan v grobu 2/57 na Prelogah.

Kačaste fibule s ploščico različic **VIa**, **VIb** in **VIc** (sl. 88: 12–14) so bolj redke. Iz gomile 13 na Prelogah je znana le ena skromna grobna celota (13/41), ki je vsebovala še dve modri jagodi, ter tri iz gomile IV na Prelogah, ki niso popolne oz. zanesljive (IV/32, IV/33, IV/37).

V nekaj več primerih se pojavljata različici **VIIa** oz. **VIIb** (sl. 88: 7, 15). Različica VIIa je pripadala deklici, ki je nosila svinčeno ovratnico in dve narebreni zapestnici (Voselca, gr. 2/7); različica VIIb pa je zastopana v ženskih opravah z valjastimi uhani, jantarnimi in modrimi steklenimi ogrlicami (Preloge, gr. X/4, 13/152). Opazimo jih lahko tudi v moških grobovih, kjer običajno nastopajo v paru (Preloge, gr. 2/46, 2/62).

Razširjenost in časovni okvir. Primerjava med najdišči dolenske halštatske skupnosti razkriva, da je

at Preloge, documented together with an iron rhombic belt clasp and an iron knife. A fibula of Variant **IIIb** is published as part of Grave II/1a (fig. 88: 1), of which no other data is available.

The serpentine fibulae that saw the widest distribution were those of simple forms, marked here as Variants **IVa** and **IVb** (fig. 88: 5, 6). They were worn by women, children and also men (fig. 89). Variant IVa is recorded in two cremation graves – Grave 2/4 from Voselca as the sole grave good in an urn, while Grave X/43 at Preloge contained, according to Goldberg, a serpentine fibula with six earrings threaded onto it, a bow fibula, a bronze needle and two vessels. These contents do not correspond to the publication of the group, which lists two serpentine fibulae of Variant IVa, two crossbow Certosa fibulae of Type XIII, eight band earrings and two needles. Variant IVb was also recorded in the grave of a chieftain with a double-crested helmet from Tumulus VII at Preloge (VII/39), whereby the serpentine fibula reportedly lay near the deceased's neck. The second male with such a fibula was less well equipped (Laščik, Gr. V/27). The table on fig. 89 shows that women usually wore a single fibula of the type in combination with flat wire earrings or wide band earrings with a hook and two solid ribbed bracelets. The costume with Variant IVb fibulae further consists of necklaces of large amber beads (glass beads are rare and usually either blue or transparent), sometimes also of a roll- or spherical-headed hair pin and a pair of knobbed torques. The fibulae may appear in combination with other types – a small bow fibula (child's Grave 2/81 at Preloge), a serpentine fibula with wings (child's Grave 2/12 at Voselca), a bow (Grave X/43) and a "western Hallstatt" fibula (Grave IV/41).

Serpentine fibulae with wings of Type **V** formed part of a richer costume (fig. 88: 11 and fig. 89). The latter further consisted of four cylindrical earrings, amber and glass beads, a spherical-headed pin, two solid ribbed bracelets, two hollow armlets and gold foil or sceptre. In Grave X/72, a Type V serpentine fibula was found in combination with a boat fibula of Variant 3b after Jerin, while in child's Grave X/67 together with a Certosa fibula of Type I after Teržan. A pair of Type V serpentine fibulae was worn by the owner of a double-crested helmet buried in Grave 2/57 at Preloge.

Serpentine fibulae with a plate of Variants **VIa**, **VIb** and **VIc** (fig. 88: 12–14) are rare finds. One was found in Tumulus 13 at Preloge, as part of a modest grave group (13/41) that also contained two blue beads. Three other fibulae formed parts of grave groups in Tumulus IV at Preloge, but they are either unreliable or incomplete (IV/32, IV/33, IV/37).

Slightly better represented are Variants **VIIa** and **VIIb** (fig. 88: 7, 15). A Variant VIIa fibula belonged to a girl that also wore a lead torque and two ribbed bracelets (Voselca, Gr. 2/7). Variant VIIb fibulae formed part of the female costume that included cylindrical earrings as

Kačaste fibule / Serpentine fibulae (n = 373)

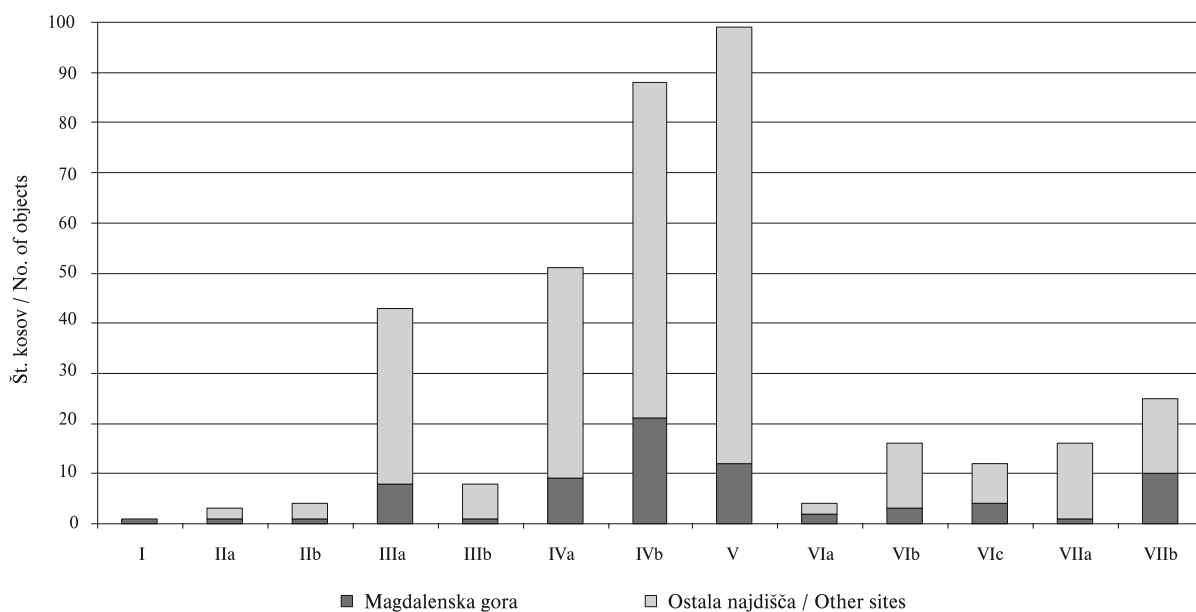

Najdišče Site	Različice kačastih fibul / Variants of serpentine fibulae													Skupaj Total
	I	IIa	IIb	IIIa	IIIb	IVa	IVb	V	VIa	VIb	VIc	VIIa	VIIb	
Vače			3	8	2	3	20	26		3		4	6	75
Stična		1		12		15	18	19		4	1	4		74
Magdalenska gora	1	1	1	8	1	9	20	12	2	3	4	1	10	73
Veliki Vinji vrh (Šmarjeta)		1		4		9	4	9		1	6	3	5	42
Libna				4	4	4		6		1		1		20
Brezje				2		1	4	7		2	1			17
Novo mesto				1		2							2	5
Podzemelj				1		2		2						5
Dragatuš							1							1

Stopnje / Phases	Vrste kačastih fibul / Types of serpentine fibulae													
Stična	I													VII a
2														
Kačaste fibule Serpentine fibulae	II													VII a
2	III													VII a
Certoške fibule Certosa fibulae	IV													VII a
1	V													VII a
1	VI													VII b
1	VII b													VII b

Sl. 90: Številčno razmerje in časovni razpon posameznih tipov kačastih fibul v dolenski skupnosti.
Fig. 90: Quantitative ratio and chronological span of individual types of serpentine fibulae in the Dolenjska community.

največ primerkov kačastih fibul znanih s severozahodnih središč – Vače, Magdalenska gora in Stična (sl. 90). Bolj ko gremo proti jugu, manj številne so (Brezje, Novo mesto, okolica Velikega Vinjega vrha oz. Šmarjete, Libna), na belokranjskih najdiščih (Podzemelj, Dragatuš) pa so zabeleženi le redki primerki.

Kačasta fibula z dvema zankama (tip I) z Magdalenske gore je poleg dveh primerkov z Mosta na Soči edini tak kos v jugovzhodnih Alpah.⁹⁹⁴ Ta oblika je bila bolj razširjena na območju med rekama Adižo in Piavo, na zahodu je dosegla prostor golaseške kulture, na jugu Bologno, najbolj severno pa jo zasledimo onkraj Donave v depoju Abraham, kot je pokazala Teržanova, ki jih datira na konec 7. st. pr. n. št.,⁹⁹⁵ to je čas stopnje Stična 2 na Dolenjskem. Ob tem velja še enkrat izpostaviti, da je bila na Magdalenski gori najdena v žganem grobu.

Tudi za kačaste fibule z valovitim lokom je moč trditi, da ne predstavljajo tipične sestavine dolenjske noše. Posamični primerki različice IIa so znani iz Stične in iz okolice Velikega Vinjega vrha (Šmarjete),⁹⁹⁶ medtem ko različico IIb zasledimo samo še na Vačah.⁹⁹⁷ Pojav takih fibul je omejen na severnojadranski lok – od Este, zgornjega porečja Piave in Soče, Notranjske s Krasom, Istre do zahodne Dolenjske. Karti razprostranjenosti, ki sta ju malodane sočasno priobčila Lunz in Teržanova, se dopolnjujeta.⁹⁹⁸ Edini ohranjeni grobni celoti z območja dolenjske halštatske skupnosti sta znani z Magdalenske gore (Preloge, gr. VII/29, VII/32). Tudi na Mostu na Soči jih zasledimo običajno v skromnih sestavih, skupaj z eno posodo; bogatejši je bil le grob 2027, ki je vseboval poleg kačaste fibule različice IIa še dve t. i. protocertoski fibuli, iglo s kroglasto glavico z izrastkom, železen nož in dve posodi.⁹⁹⁹ V Posočju so datirane v stopnjo Sv. Lucija Ic2.¹⁰⁰⁰

Bolj razširjeno obliko predstavljata različici IIIa in IIIb, okrašeni s pestiči in rozetami ali koleščki. Take fibule je Parzinger opredelil kot tipično nadregionalno prvino njegovega časovnega horizonta 5, ki družijo severnoitalski, zahodnohalštatski in jugovzhodnoalpski svet. Dopolnil je Kossackov in Mansfeldov seznam najdišč, vendar je bila tudi njegova karta razprostranjenosti

well as amber and blue glass necklaces (Preloge, Gr. X/4, 13/152). They were also found in male graves, usually in pairs (Preloge, Gr. 2/46, 2/62).

Distribution and time frame. A comparison between the numbers of serpentine fibulae from individual sites reveals that most were found at the north-western centres, namely Vače, Magdalenska gora and Stična (fig. 90). Their number decreases towards the south (Brezje, Novo mesto, Veliki Vinji vrh (Šmarjeta), Libna), while only rare examples came to light in Bela krajina (Podzemelj, Dragatuš).

The two-looped serpentine fibula (Type I) from Magdalenska gora represents, beside two other from Most na Soči, the only example of the type in the south-eastern Alps.⁹⁹⁴ Teržan showed that the type was most widespread in the area between the rivers Adige and Piave, reaching in the west to the area of the Golasecca culture, to the south to Bologna, while the northernmost examples were found beyond the Danube, in the Abraham hoard. She also proposed a date for the type, namely end of the seventh century BC,⁹⁹⁵ which is the Stična 2 phase in Dolenjska. It is worth noting that, at Magdalenska gora, such a fibula was found in a cremation grave.

Serpentine fibulae with a wavy bow also do not represent a typical element of the Dolenjska costume. Individual examples of Variant IIa are known from Stična and around Veliki Vinji vrh (Šmarjeta),⁹⁹⁶ while Variant IIb are only evidenced at Vače and Magdalenska gora.⁹⁹⁷ The appearance of these fibulae is limited to the northern Adriatic area – from Este, upper reaches of the Piave and Soča, Notranjska with the Kras, to Istria and western Dolenjska, whereby the distribution maps, published almost contemporaneously by Teržan and Lunz, show the complete picture.⁹⁹⁸ The only two preserved grave groups from the area of the Dolenjska Hallstatt community were found at Magdalenska gora (Preloge, Gr. VII/29, VII/32). At Most na Soči, as well, they were found in poor graves, accompanied by a single vessel. The only exception is Grave 2027, which contained a Variant IIa serpentine fibula, two proto-Certosa fibulae, a spherical-headed pin with a protrusion, an iron knife and two vessels.⁹⁹⁹ In the Soča Valley, these fibulae date to the Sv. Lucija Ic2 phase.¹⁰⁰⁰

⁹⁹⁴ Lunz 1974, 139 u, T. 10: 6, 91A; Teržan 1987, Fig. 12.

⁹⁹⁵ Teržan 1987, 19.

⁹⁹⁶ *Magdalenska gora*: Hencken 1978, Fig. 252c; *Stična*: Gabrovec et al. 2006, T. 162: 16; *Veliki Vinji vrh (Šmarjeta)*: Stare V. 1973a, T. 20: 9.

⁹⁹⁷ *Magdalenska gora*: Hencken 1978, Fig. 249; *Vače*: Stare F. 1955a, T. 26: 3 in neobjavljen primerek, NHMW inv. št. 7930.

⁹⁹⁸ Teržan/Trampuž 1973, sl. 2.3; Lunz 1974, 134e, T. 39: 3, 83A.

⁹⁹⁹ Gr. 852, 1032, 1183, 1176, 1419, 1463, 1595, 1992, 2027, 2340-1: Teržan/Lo Schiavo/Trampuž-Orel 1984, 84C:1, 106E: 1, 113E: 1, 115A: 1, 131F: 1, 133F: 2, 150F, 200A: 1, 205A:3, 247B:1,2.

¹⁰⁰⁰ Teržan/Trampuž 1973, 427.

⁹⁹⁴ Lunz 1974, 139 u, T. 10: 6, 91A; Teržan 1987, Fig. 12.

⁹⁹⁵ Teržan 1987, 19.

⁹⁹⁶ *Magdalenska gora*: Hencken 1978, Fig. 252c; *Stična*: Gabrovec et al. 2006, T. 162: 16; *Veliki Vinji vrh (Šmarjeta)*: Stare V. 1973a, T. 20: 9.

⁹⁹⁷ *Magdalenska gora*: Hencken 1978, Fig. 249; *Vače*: Stare F. 1955a, T. 26: 3 and an unpublished example, NHMW Inv. No. 7930.

⁹⁹⁸ Teržan/Trampuž 1973, Fig. 2.3; Lunz 1974, 134e, T. 39: 3, 83A.

⁹⁹⁹ Gr. 852, 1032, 1183, 1176, 1419, 1463, 1595, 1992, 2027, 2340-1: Teržan/Lo Schiavo/Trampuž-Orel 1984, 84C:1, 106E: 1, 113E: 1, 115A: 1, 131F: 1, 133F: 2, 150F, 200A: 1, 205A:3, 247B:1,2.

¹⁰⁰⁰ Teržan/Trampuž 1973, 427.

deležna poznejših dopolnitev.¹⁰⁰¹ V dolenjski halštatski skupnosti je največ primerkov znanih s severozahodnih najdišč – z Vač, Magdalenske gore in iz Stične (*sl.* 90), kjer jih lahko opazimo tudi v moški noši, kar je pomembna novost, saj so dotlej moški spenjali oblačila z iglami in ne s fibulami. Na Magdalenski gori resda lahko samo domnevamo, da sta pripadali moškemu v grobu 13/95 (fibuli sta namreč izgubljeni), vendar pa nedvomni dokaz prinaša grob 48/76 iz Stične, ki je vseboval dve železni sulici.¹⁰⁰² V tem pogledu so zanimivi še svetolucijski grobovi, kjer se take fibule pojavljajo v kombinaciji z večglavimi iglami, v grobu 2077 pa z železnim nožem.¹⁰⁰³ Bolj redka je različica IIIb z zlito zanko, ki jo je Kossack poimenoval tip Vače-Uffing, Guštin pa kot varianto Este-Vače-Uffing, od katere je ločil lokalno izvedbo tip Tržišče, ki je omejena samo na notranjsko-posoško regijo.¹⁰⁰⁴ Na Dolenjskem so znani štirje primerki različice IIIb z Libne, dva z Vač, po eden pa iz Rovišča in Magdalenske gore. V nekaterih grobovih iz svetolucijske nekropole zasledimo obe različici skupaj,¹⁰⁰⁵ kar govori za njuno sočasnost.¹⁰⁰⁶ Fibule s pestiči srečamo ponekod na Dolenjskem še v kombinaciji z različico VIIa, s čolničastimi fibulami 3c ali 6a po Jerinovi, s trortastimi ali s fibulami z oblogo, ki so značilnost stopnje Stična 2, pa tudi z nekoliko mlajšimi dolgonožnimi ločnimi fibulami.¹⁰⁰⁷ V svetolucijski skupnosti se pojavljajo v časovnem razponu od stopnje Sv. Lucija Ic1 do Iib.¹⁰⁰⁸

Različici **IVa** in **IVb** nista bili priljubljeni le na Magdalenski gori, temveč v vsej dolenjski skupnosti.¹⁰⁰⁹ V ženski noši jih zasledimo skupaj z jantarnimi

¹⁰⁰¹ Parzinger 1988, T. 142.2; Glunz 1997, Karte 14; Jablonka 2001, 112, Karte 4, T. 80: 4.

¹⁰⁰² Gabrovec et al. 2006, T. 44: 1,2.

¹⁰⁰³ Gr. 55, 770, 1603, 1841, 2053, 2134, 2411, 2206: Teržan/Lo Schiavo/Trampuž-Orel 1984, T. 8F: 1, 76G: 1, 149I: 1, 177D: 1, 206: 1-5, 210B: 1, 219A: 1, 228C: 1, 257D: 1.

¹⁰⁰⁴ Kossack 1959, T. 155B; Guštin 1973, karta 3, op. 51; Glunz 1997, Karte 16.

¹⁰⁰⁵ Gr. 776, 1881, 2354: Teržan/Lo Schiavo/Trampuž-Orel 1984, T. 77D: 1,2, 180B: 1,2, 248B: 3,4.

¹⁰⁰⁶ Parzinger 1988, T. 142.2.

¹⁰⁰⁷ Brezje, gr. 13/18: Kromer 1959a, T. 51: 2; Libna-Špilerjeva gom. 2/gr. 5, Libna-Deržaničeva gom. 5/gr. C: Guštin 1976, T. 6: 8, 59: 3,4; Novo mesto-Kapiteljska njiva, gr. 1/26: Knez 1993, T. 25: 10; Stična, gr. 48/27, 5/4: Gabrovec et al. 2006, T. 18: 38,39, 109: 3.

¹⁰⁰⁸ Gr. 1002, 1599, 2008, 2113, 2189, 2206, 2221, 2233, 2434: Teržan/Trampuž 1973, 422 ss; Teržan/Lo Schiavo/Trampuž-Orel 1984, T. 102A: 1,2, 150A: 1, 202B: 1, 215A: 3, 225A: 5, 233A: 1, 230C: 2, 263A: 1,3.

¹⁰⁰⁹ Brezje, gr. 7/17, 7/41: Kromer 1959a, T. 1: 2, 12: 3; Dragatuš, gr. 1/5: Spitzer 1973, T. 5: 7; Škvor Jernejčič 2011, T. 6: 7; Javor, gr. 7-9: Guštin/Knific 1973, T. 2: 6, 3: 1,8; Kladje nad Blanco, gr. 1/c: Dular J. 2003, T. 50: 5; Libna, Volavškova gom./gr. 6: Guštin 1976, T. 61: 18; Podzemelj: Dular 1978, T. 3: 16,17; Rihpovec-Zelkova hosta, gr. 1, 8: Dular J. 2003, T. 32: 2, 34: 4,5; Stična, gr. 48/17, 48/26, 48/37, 48/40, 48/81,

More widespread are Variants **IIIa** and **IIIb**, decorated with antennae and rosettes or wheels. These were determined by Parzinger as a typical interregional element of his Horizon 5 and shared by the north Italian, west Hallstatt and south-eastern Alpine worlds. He also supplemented the lists of sites proposed by Kossack and Mansfeld, which were later further supplemented.¹⁰⁰¹ In the Dolenjska Hallstatt community, most examples are known from the north-western sites, namely Vače, Magdalenska gora and Stična (*fig.* 90). Here they also formed parts of the male costume, which represents an important novelty, since up to that time men fastened their clothing with pins rather than fibulae. It is true that the two fibulae from Magdalenska gora only supposedly belonged to the man buried in Grave 13/95 (fibulae are now lost), but clear male evidence is provided by Grave 48/76 at Stična that also contained two iron spears.¹⁰⁰² Even more interesting in this sense are the Sveta Lucija graves, where such fibulae appear in combination with multi-knobbed pins and in Grave 2077 with an iron knife.¹⁰⁰³ Less numerous is Variant IIIb made of one piece with a cast loop, determined by Kossack as Type Vače-Uffing and by Guštin as Variant Este-Vače-Uffing, separating from it the local form of Type Tržišče limited to Notranjska and the Soča Valley.¹⁰⁰⁴ In Dolenjska, four examples of Variant IIIb are known from Libna, two from Vače, and one from Rovišče and Magdalenska gora, respectively. Some graves from the cemetery at Most na Soči even yielded both variants together,¹⁰⁰⁵ which speaks of their contemporaneity.¹⁰⁰⁶ In Dolenjska, fibulae with antennae were also found in combination with Variant VIIa fibulae, boat fibulae of Types 3c or 6a after Jerin, three-knobbed fibulae, fibulae with an overlay (characteristic of the Stična 2 phase), but also with the somewhat later bow fibulae with a long foot.¹⁰⁰⁷ Within the Sveta Lucija community, their appearance spans from the Sv. Lucija Ic1 to Iib phases.¹⁰⁰⁸

¹⁰⁰¹ Parzinger 1988, T. 142.2; Glunz 1997, Karte 14; Jablonka 2001, 112, Karte 4, T. 80: 4.

¹⁰⁰² Gabrovec et al. 2006, T. 44: 1,2.

¹⁰⁰³ Gr. 55, 770, 1603, 1841, 2053, 2134, 2411, 2206: Teržan/Lo Schiavo/Trampuž-Orel 1984, T. 8F: 1, 76G: 1, 149I: 1, 177D: 1, 206: 1-5, 210B: 1, 219A: 1, 228C: 1, 257D: 1.

¹⁰⁰⁴ Kossack 1959, T. 155B; Guštin 1973, Cart. 3, n. 51; Glunz 1997, Karte 16.

¹⁰⁰⁵ Gr. 776, 1881, 2354: Teržan/Lo Schiavo/Trampuž-Orel 1984, T. 77D: 1,2, 180B: 1,2, 248B: 3,4.

¹⁰⁰⁶ Parzinger 1988, T. 142.2.

¹⁰⁰⁷ Brezje, Gr. 13/18: Kromer 1959a, T. 51: 2; Libna-Špiler Tum. 2/Gr. 5, Libna-Deržanič Tum. 5/Gr. C: Guštin 1976, T. 6: 8, 59: 3,4; Novo mesto-Kapiteljska njiva, Gr. 1/26: Knez 1993, T. 25: 10; Stična, Gr. 48/27, 5/4: Gabrovec et al. 2006, T. 18: 38,39, 109: 3.

¹⁰⁰⁸ Gr. 1002, 1599, 2008, 2113, 2189, 2206, 2221, 2233, 2434: Teržan/Trampuž 1973, 422 ff; Teržan/Lo Schiavo/Trampuž-Orel 1984, T. 102A: 1,2, 150A: 1, 202B: 1, 215A: 3, 225A: 5, 233A: 1, 230C: 2, 263A: 1,3.

in steklenimi ogrlicami, pretežno iz modrih jagod, s parom narebrenih zapestnic in uhanov iz trakaste žice z vzdolžno kaneluro in presegajočimi konci. Pojavljajo se tudi v kombinaciji s kačasto fibulo različice VIIa, s fibulo sanguisuga, alpsko dvortasto fibulo ter dvortasto fibulo z rombično razširjenim lokom in s trakasto fibulo. V moških grobovih so izpričane na Magdalenski gori (Laščik, gr. V/27, Preloge, gr. VII/39) in v Rihpovcu (gr. 1). Na Mostu na Soči srečamo kačaste fibule različic IVa in IVb skupaj z različicami IIIa, IIIb in VIIa, pa tudi z dvoankasto fibulo tipa 1a po Gabrovcu, s čolničasto ali trortasto fibulo, kar kaže na njihov vznik že v stopnji Sv. Lucija Ic2. Da so se obdržale vse do stopnje Sv. Lucija IIb, pričajo sestavi z razvitejšo obliko kačastih fibul tipa V in certoško vrste II po Teržanovi.¹⁰¹⁰ Parzinger jih je označil za jugovzhodnoalpsko značilnost horizonta 6, seznam najdišč je nazadnje dopolnila Nascimbenejeva in jih predstavila kot vzhodnoalpski *koiné*.¹⁰¹¹

Drugo najpogostejšo obliko na Dolenjskem predstavljajo kačaste fibule s krilci tipa V (sl. 90), ki so jih moški nosili običajno v paru,¹⁰¹² medtem ko se v ženskih opravah pojavljajo skupaj s fibulami s stekleno oblogo, šmarješko čolničasto, trakasto fibulo in s certoško vrste V po Teržanovi.¹⁰¹³ Na Dolenjskem jih nikoli ne zasledimo z variantami, ki imajo pestiče (tip III), zato je bi lahko sodili, da so prišle v modo nekoliko pozneje, kar nakazuje tudi stratigrafska situacija v Volčjih Njivah.¹⁰¹⁴ Enako meni Nascimbenejeva.¹⁰¹⁵ V svetolucijski skupnosti je časovni okvir njihove uporabe določen z grobnimi sestavi, v katerih nastopajo z dvoankasto fibulo 1a po Gabrovcu, s čolničasto fibulo 3. vrste po Jerinovi,

48/84, 48/86, 48/109, 48/136, 48/138, 48/147, 48/151, 48/153, 48/157, 48/162, 48/163, 48/164, 48/172, 48/178: Gabrovec et al. 2006, T. 10: 1, 15: 1, 28: 1, 47: 1-3, 49: 1, 65: 1, 78: 1,2, 79: 2,3, 85: 2, 87: 1, 88: 1, 90: 1, 93: 1,2, 94: 1,2, 99: 1 103: 1; *Veliki Vinji vrh (Šmarjeta)-Čevnice pri Žalovičah, gr. VI(1896)/1*: Dular A. 1991, T. 48: 1; *Volčje Njive, gr. 9*: Gabrovec 1956, T. 10: 5; Teržan 1976, sl. 54: 8.

¹⁰¹⁰ Gr. 660, 701, 908, 1103, 1109, 1204, 1673, 1688, 1738, 1866, 1876, 1960, 2063, 2354, 2439: Teržan/Lo Schiavo/Trampuž-Orel 1984, T. 61D: 5,6, 67B: 1, 91A: 7,8, 110H: 2, 111D: 2, 117G: 2, 159A: 1, 161D: 1,2,4-6, 164D: 1, 178C: 1-5, 178F: 4, 193A: 5, 208C: 1-3, 248B: 1-5, 260A: 1-4, 261B: 4.

¹⁰¹¹ Parzinger 1988, 143.1: 2; Glunz 1997, karte 17; Nascimbene 2009, Fig. 13, Tab. 3.

¹⁰¹² *Libna-Glogovškova gom. I/gr. 7*: Guštin 1976, 39, T. 23: 12 (med prdatki je omenjena železna pasna spona, ki je značilna predvsem za moško nošo); *Magdalenska gora-Preloge, gr. 2/57; Stična, gr. 5/10, 5/21-22, 5/25, 48/12*: Gabrovec et al. 2006, T. 6: 1,2, 115: 1, 122: 1,2, 124: 1,2; *Zagorica pri Čatežu-Martinov britof*: Dular J. 2003, T. 39: 1,2.

¹⁰¹³ *Brezje, gr. 1/14, 7/2, 7/33, 13/22*: Kromer 1959a, T. 3: 7, 31: 4, 47: 3, 50: 6; *Brusnice, gr. 21/3*: Teržan 1974, T. 16: 6-9; *Libna-Glogovškova gom./gr. 19*: Guštin 1976, T. 28: 3,4; *Stična, gr. 48/136, 48/163, 48/179*: Gabrovec et al. 2006, T. 78: 1-6, 94: 1,2, 103: 2.

¹⁰¹⁴ Teržan 1976, sl. 54: 10.

¹⁰¹⁵ Nascimbene 2009, 76 ss, Fig. 15, 16, Tab. 4.

Variants IVa and IVb were popular not only at Magdalenska gora, but across the Dolenjska community.¹⁰⁰⁹ They formed part of the female costume together with amber and glass necklaces, mostly of blue beads, with a pair of ribbed bracelets and earrings of flat wire with a longitudinal groove and overlapping ends. They also appear in combination with a Variant VIIa serpentine fibula, a leech fibula, Alpine two-knobbed fibulae and another with a rhomboid bow, as well as a band bow fibula. They were also found in male graves, namely at Magdalenska gora (Laščik, Gr. V/27, Preloge, Gr. VII/39) and Rihpovec (Gr. 1). At Most na Soči, serpentine fibulae of Variants IVa and IVb were found together with Variants IIIa, IIIb and VIIa, but also with a two-looped fibula of Type 1a after Gabrovec, boat or three-knobbed fibula, which indicates the beginning of their use already in the Sv. Lucija Ic2 phase. They remained in use until the Sv. Lucija IIb phase, as evidenced by grave groups with Type V serpentine fibulae and a Certosa fibula of Type II after Teržan.¹⁰¹⁰ Parzinger marked them as a southeastern Alpine characteristic of Horizon 6. His site list was last supplemented by Nascimbene, who saw them as an eastern Alpine *koiné*.¹⁰¹¹

The second most frequent form in Dolenjska is the serpentine fibula with wings of Type V (fig. 90). These were worn by men usually in pairs,¹⁰¹² while the female costume combined them with fibulae with a glass overlay, a Šmarjeta boat fibula, a band bow fibula and a Certosa fibula of Type V after Teržan.¹⁰¹³ In Dolenjska, they

¹⁰⁰⁹ *Brezje, Gr. 7/17, 7/41*: Kromer 1959a, T. 1: 2, 12: 3; *Dragatuš, Gr. 1/5*: Spitzer 1973, T. 5: 7; Škvor Jernejčič 2011, T. 6: 7; *Javor, Gr. 7-9*: Guštin/Knific 1973, T. 2: 6, 3: 1,8; *Kladje nad Blanco, Gr. 1/c*: Dular J. 2003, T. 50: 5; *Libna, Volavšek Tum./Gr. 6*: Guštin 1976, T. 61: 18; *Podzemelj*: Dular 1978, T. 3: 16,17; *Rihpovec-Zelkova hosta, Gr. 1, 8*: Dular J. 2003, T. 32: 2, 34: 4,5; *Stična, Gr. 48/17, 48/26, 48/37, 48/40, 48/81, 48/84, 48/86, 48/109, 48/136, 48/138, 48/147, 48/151, 48/153, 48/157, 48/162, 48/163, 48/164, 48/172, 48/178*: Gabrovec et al. 2006, T. 10: 1, 15: 1, 28: 1, 47: 1-3, 49: 1, 65: 1, 78: 1,2, 79: 2,3, 85: 2, 87: 1, 88: 1, 90: 1, 93: 1,2, 94: 1,2, 99: 1 103: 1; *Veliki Vinji vrh (Šmarjeta)-Čevnice near Žaloviče, Gr. VI(1896)/1*: Dular A. 1991, T. 48: 1; *Volčje Njive, Gr. 9*: Gabrovec 1956, T. 10: 5; Teržan 1976, Abb. 54: 8.

¹⁰¹⁰ Gr. 660, 701, 908, 1103, 1109, 1204, 1673, 1688, 1738, 1866, 1876, 1960, 2063, 2354, 2439: Teržan/Lo Schiavo/Trampuž-Orel 1984, T. 61D: 5,6, 67B: 1, 91A: 7,8, 110H: 2, 111D: 2, 117G: 2, 159A: 1, 161D: 1,2,4-6, 164D: 1, 178C: 1-5, 178F: 4, 193A: 5, 208C: 1-3, 248B: 1-5, 260A: 1-4, 261B: 4.

¹⁰¹¹ Parzinger 1988, 143.1: 2; Glunz 1997, karte 17; Nascimbene 2009, Fig. 13, Tab. 3.

¹⁰¹² *Libna-Glogovšek Tum. I/Gr. 7*: Guštin 1976, 39, T. 23: 12 (an iron belt clasp, which is a typical male attribute, is mentioned among the grave goods); *Magdalenska gora-Preloge, Gr. 2/57; Stična, Gr. 5/10, 5/21-22, 5/25, 48/12*: Gabrovec et al. 2006, T. 6: 1,2, 115: 1, 122: 1,2, 124: 1,2; *Zagorica pri Čatežu-Martinov britof*: Dular J. 2003, T. 39: 1,2.

¹⁰¹³ *Brezje, Gr. 1/14, 7/2, 7/33, 13/22*: Kromer 1959a, T. 3: 7, 31: 4, 47: 3, 50: 6; *Brusnice, Gr. 21/3*: Teržan 1974, T. 16: 6-9;

trortasto in svetolucijsko fibulo ter trakasto in certoško fibulo vrste I po Teržanovi.¹⁰¹⁶

Sočasno s tipoma IV in V so bile v uporabi še kačaste fibule s ploščico, tj. tip VI.¹⁰¹⁷ Redki ohranjeni konteksti kažejo, da so jih poleg žensk morda nosili tudi moški. Izdelovalno središče takih fibul je bilo verjetno na Mostu na Soči, kjer so najštevilnejše, od koder so se dozdevno razširile v zgornje Poadižje in v skupnost ob reki Piavi, na jug v Istro, na vzhod pa tja do štajerskega Rifnika.¹⁰¹⁸ V grobovih z Mosta na Soči jih zasledimo v kombinacijah s tipoma V in VII, s čolničasto fibulo 3. vrste po Jerinovi, s trortasto in trakasto fibulo, pa tudi s certoško fibulo vrste V po Teržanovi.¹⁰¹⁹

Oblikovna različica VIIa z zanko na loku se je na Dolenjskem pojavila že v stopnji Stična 2, vendar v tej skupnosti ni nikoli prišla v širšo uporabo (sl. 90). Parzinger je bronaste primerke opredelil kot južnoalpsko varianta kačastih fibul S4 po Mansfeldu, ki odražajo nadregionalne povezave v času horizonta 6. Razširjene so bile vse od Padske nižine do severnoalpskega obrobja in na jugovzhodu do reke Save, podobno kot različica IIIa s pestiči, ki jo je predstavil v okviru 5. horizonta.¹⁰²⁰ Toda ne le stiški grob 48/27, temveč tudi nekateri grobovi z Mosta na Soči¹⁰²¹ dokazujejo, da sta bila oba tipa v jugovzhodnih Alpah sočasno v uporabi. Različica IIIa je v kačastem horizontu postopno izginila, medtem ko se je različica VIIa obdržala vse do certoške stopnje.¹⁰²² Razvile so se v obliko, ki jo predstavlja različica VIIb s trakastim lokom in masivnejšim kroglastim zaključkom noge s čepastim nastavkom. Slednje srečamo na Dolenjskem v certoški in v negovski stopnji.¹⁰²³ V kombinaciji s certoškimi fibulami vrst IX in X po Teržanovi jih zasledimo v Este (Benvenuti 111) in na Mostu na Soči (gr. 2318).¹⁰²⁴

¹⁰¹⁶ Gr. 271, 656, 908, 1193, 1634 : Teržan 1976, sl. 12: 4,5, 14: 1; Teržan/Lo Schiavo/Trampuž-Orel 1984, T. 26E: 3,4, 57E: 1,2, 91A: 7,8, 116: 4.

¹⁰¹⁷ Brezje, gr. 7/32, 7/42: Kromer 1959a, T. 30: 4, 34: 3; Čužnja vas, gr. 2/5: Dular J. 2003, T. 20: 3; Rihpovec-Ostrvec, gr. 5: *ibid.*, 31: 1,2; Stična, gr. 48/129, 131, 147: Gabrovec et al. 2006, T. 75: 3,4, 76: 1, 85: 1,2.

¹⁰¹⁸ Teržan 1990a, karta 20; Nascimbene 2009, 87 ss, Fig. 18, Tab. 6.

¹⁰¹⁹ Gr. 1096, 1206, 1591, 1792, 2066, 2107, 2119, 2165: Teržan/Lo Schiavo/Trampuž-Orel 1984, T. 110F, 117I, 149G, 171G, 208D, 213A, 216F, 221E.

¹⁰²⁰ Parzinger 1988, T. 142.2, s. 143.2; Glunz 1997, karte 20.

¹⁰²¹ Gr. 1673, 2008, 2113, 2206, 2221, 2354, 2434, 2439: Teržan/Lo Schiavo/Trampuž-Orel 1984, T. 159A, 202B, 215A, 228C, 230C, 248B, 260A, 261B, 263A.

¹⁰²² Magdalenska gora – Voselca, gr. 2/7; Most na Soči, gr. 1096, 2063, 2165: Teržan/Lo Schiavo/Trampuž-Orel 1984, T. 110F, 208C, 221E; Stična, gr. 48/54, 48/157: Gabrovec et al. 2006, T. 34: 1,2, 90: 2.

¹⁰²³ Novo mesto-Kapiteljska njiva, gr. 3/41: Križ 1997, T. 64: 4; Roje pri Trebelnem: Dular J. 2003, T. 29: 4.

¹⁰²⁴ Teržan 1976, sl. 21: 2, 34.

never appear alongside variants with antennae (Type III). This would indicate that they became fashionable somewhat later, which is supported by the stratigraphic situation at Volčje Njive.¹⁰¹⁴ The latter was also observed by Nascimbene.¹⁰¹⁵ Their time frame within the Sveta Lucija community is determined by grave groups that combine them with a two-looped fibula of Type 1a after Gabrovec, a boat fibula of Group 3 after Jerin, a three-knobbed, a Sveta Lucija as well as a band bow and Certosa fibulae, the latter of Type I after Teržan.¹⁰¹⁶

In use contemporaneously with Types IV and V were the serpentine fibulae with a plate, of Type VI.¹⁰¹⁷ The rare preserved contexts with this fibula type show that they were worn by women, but possibly also by men. Their production centre was most likely situated at Most na Soči, where they are most numerous represented and whence they presumably spread into the upper Adige basin and into the community along the Piave, to the south in Istria and to the east to Rifnik in Štajerska.¹⁰¹⁸ They were found in the graves at Most na Soči in combination with Types V and VII, boat fibula of Group 3 after Jerin, three-knobbed and band bow fibula, but also a Certosa fibula of Type V after Teržan.¹⁰¹⁹

Variant VIIa with a loop on the bow appeared in Dolenjska already in the Stična 2 phase, though it never came to be widely used (fig. 90). The bronze examples were determined by Parzinger as the South Alpine variant of serpentine fibulae of S4 after Mansfeld, which reflect the interregional connections in the time of Horizon 6. Their distribution covers an area from the Po Plain to the northern fringes of the Alps and the river Sava to the east, similarly as Variant IIIa with antennae, which Parzinger presented within his Horizon 5.¹⁰²⁰ Their contemporaneity in the south-eastern Alps is proven not only by Grave 48/27 from Stična, but also by several graves from Most na Soči.¹⁰²¹ Variant IIIa gradually disappeared in the Serpentine Fibulae phase,

Libna-Glogovšek Tum./Gr. 19: Guštin 1976, T. 28: 3,4; Stična, Gr. 48/136, 48/163, 48/179: Gabrovec et al. 2006, T. 78: 1-6, 94: 1,2, 103: 2.

¹⁰¹⁴ Teržan 1976, Abb. 54: 10.

¹⁰¹⁵ Nascimbene 2009, 76 ff, Figs. 15, 16, Tab. 4.

¹⁰¹⁶ Gr. 271, 656, 908, 1193, 1634: Teržan 1976, Abb. 12: 4,5, 14: 1; Teržan/Lo Schiavo/Trampuž-Orel 1984, T. 26E: 3,4, 57E: 1,2, 91A: 7,8, 116: 4.

¹⁰¹⁷ Brezje, Gr. 7/32, 7/42: Kromer 1959a, T. 30: 4, 34: 3; Čužnja vas, Gr. 2/5: Dular J. 2003, T. 20: 3; Rihpovec-Ostrvec, Gr. 5: *ibid.*, 31: 1,2; Stična, Gr. 48/129, 131, 147: Gabrovec et al. 2006, T. 75: 3,4, 76: 1, 85: 1,2.

¹⁰¹⁸ Teržan 1990a, map 20; Nascimbene 2009, 87 ff, Fig. 18, Tab. 6.

¹⁰¹⁹ Gr. 1096, 1206, 1591, 1792, 2066, 2107, 2119, 2165: Teržan/Lo Schiavo/Trampuž-Orel 1984, T. 110F, 117I, 149G, 171G, 208D, 213A, 216F, 221E.

¹⁰²⁰ Parzinger 1988, T. 142.2, 143.2; Glunz 1997, Karte 20.

¹⁰²¹ Gr. 1673, 2008, 2113, 2206, 2221, 2354, 2434, 2439: Teržan/Lo Schiavo/Trampuž-Orel 1984, T. 159A, 202B, 215A, 228C, 230C, 248B, 260A, 261B, 263A.

Čeprav so kačaste fibule močno zaznamovale dolenjsko halštatsko nošo, jih ne moremo šteti za kulturno posebnost te skupnosti, saj so predstavljale vsesplošno modo, ki se je razmahnila od srednje Italije do severnega obrobja Alp. Popolnoma enak diapazon oblik, kot ga zasledimo na Dolenjskem, je zastopan tudi v svetolucijski sredini, ki je nekatere modele verjetno posredovala v jugovzhodnoalpski prostor. Najzgodnejši tipi kačastih fibul (tipi I–III), ki so razširjeni v severnoitalskem prostoru, so na Mostu na Soči zastopani v večjem številu kot na Dolenjskem, kjer se pojavljajo le v severozahodnih najdiščih, medtem ko severovzhodno od Save niso segli, z izjemo enega primerka različice IIIb iz panonskega Saghegyja. V Ljubljani in na Magdalenski gori jih zasledimo v žganih grobovih, kar jih tudi po tej plati povezuje s estensko-svetolucijskim prostorom.

Naslednjo generacijo kačastih fibul predstavljajo lokalne izvedbe (tipi IV–VI), ki so v 6. st. pr. n. št. postale tako rekoč obvezni kos ženske noše, nastopajo pa tudi v nekaterih moških opravah. Različice teh tipov so značilne za južnoalpski prostor, najpogostejše so na Mostu na Soči in v severozahodnih dolenskih središčih. Na Dolenjskem so se nosile v kombinaciji z jantarnimi ogrlicami in parom zapestnic, včasih tudi nanožnic, ali z orožjem, česar v svetolucijskih opravah ni. Razlike med obema skupnostma so vidne tudi v spremljajočih tipih uhanov, razen tega se tovrstne kačaste fibule na Dolenjskem pojavljajo povečini v skeletnih grobovih. Poslednjo generacijo kačastih fibul na Dolenjskem pa predstavlja različica VIIb, ki jo zasledimo v kontekstih certoške stopnje in negovske stopnje.

4.7.7 TRAKASTE, DOLGONOŽNE IN DROBNE LOČNE FIBULE

TRAKASTE FIBULE

Za ta tip fibul je značilno, da imajo dolgo nogo J-preseka, ki se zaključuje z vodoravno postavljenim gumbom; lok je trakast in oglato oblikovan, na prehodu v iglo pa ima vedno disk (*sl. 91: 1, 2*).

Na Magdalenski gori lahko naštejemo 20 primerkov takih fibul.¹⁰²⁵ Zanimivo je, da je bila večina najdena v gomili 2 na Prelogah, nekaj so jih zabeležili še v gomili 13 in eno samo v gomili V na Laščiku. Nosili so jih tako moški kot ženske, kar lahko sklepamo po spremljajočih najdbah (*sl. 91*). Iz prikaza strukture grobnih celot je moč razbrati, da oprave niso enotne; tiste, ki ne izvirajo gomile 2 na Prelogah, so zelo skromne. Najbolj izstopa možak, pokopan v grobu 2/58, ki je imel par takih fibul, razen tega še dve sulici, tulasto sekuro, nož in bronasto figuralno okrašeno pasno spono. V grobu 2/73 je bila najdena v kombinaciji z otroško bronasto narebreno

¹⁰²⁵ Hencken 1978, Fig. 134b, 364v; Tecco Hvala/Dular/Kocuvan 2004, 15: 3,4, 30D: 6, 37A: 14,15, 40B: 9, 53: 2,3, 58A: 8, 60A: 2, 104A: 1,2, 96E: 2, 114A: 2,3, 152: 20-22.

while Variant VIIa remained in use until the Certosa phase.¹⁰²² The latter developed into Variant VIIb with a band bow curving into a loop and a large spherical foot terminal with a protrusion, which in Dolenjska date to the Certosa and Negova phases.¹⁰²³ They appear in combination with Certosa fibulae of Types IX and X after Teržan at Este (Benvenuti 111) and Most na Soči (Gr. 2318).¹⁰²⁴

Serpentine fibulae formed an important element of the Hallstatt costume of Dolenjska. However, they were not limited to this community; they were rather an item of fashion in use across a wider area from central Italy to the northern fringes of the Alps. The exact same range of forms was recorded in both Dolenjska and the Sveta Lucija circle, whereby the latter probably acted as an intermediary that introduced certain models into the south-eastern Alps. The earliest types of serpentine fibulae (I–III), widespread in northern Italy, are represented at Most na Soči more numerous than in Dolenjska, appearing in the latter region only on the north-western sites. They did not reach north-east of the Sava, with the single exception of a Variant IIIb fibula found at Saghegy in Pannonia. They were found at Ljubljana and Magdalenska gora in cremation graves, which is another feature that ties them to the Este-Sveta Lucija area.

The next generation of serpentine fibulae is marked by local versions (Types IV–VI). They represented an almost obligatory item of the female costume in the sixth century BC, but occasionally also appeared in the male costume. Variants of these types are characteristic of the southern Alps (*Südalpine Schlangenfibeln*) and appear most numerous at Most na Soči and north-western sites of Dolenjska. In the latter area, the fibulae were worn in combination with amber necklaces and a pair of bracelets, sometimes also anklets, but also with weapons, which has not been observed in the Sveta Lucija area. Further differences between the costume in the two communities are noticeable in the accompanying types of earrings, but also in the fact that serpentine fibulae in Dolenjska appear predominantly in inhumation graves. The last generation of serpentine fibulae in Dolenjska are of Variant VIIb, found in contexts of the Certosa and Negova phases.

¹⁰²² Magdalenska gora – Voselca, Gr. 2/7; Most na Soči, Gr. 1096, 2063, 2165; Teržan/Lo Schiavo/Trampuž-Orel 1984, T. 110F, 208C, 221E; *Stična*, Gr. 48/54, 48/157; Gabrovec *et al.* 2006, T. 34: 1,2, 90: 2.

¹⁰²³ *Novo mesto-Kapiteljska njiva*, Gr. 3/41; Križ 1997, T. 64: 4; *Roje pri Trebelnem*: Dular J. 2003, T. 29: 4.

¹⁰²⁴ Teržan 1976, Abb. 21: 2, 34.

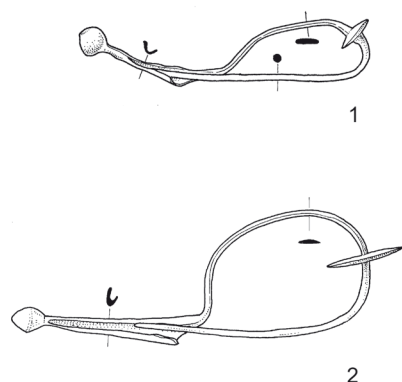

Gom. / gr. Tum. / gr.	Pokop / Burial rite	Spol / starost Sex / Age	Št. fibul / No. of fibulae	Igle / Pins	Uhani / Earrings	Ovratnice / Torques	Steklene jagode / Glass beads	Jantar / Amber	Zapestnice / Bracelets	Obeski / Pendants	Pasne spono / Belts	Sekire / Axes	Sulice / Spears	Noži / Knives	Lončenina / Pottery	Vijčki / Spindle whorls
P 13/92	S	?	1													
L V/28	S	?	2													
P 13/136	S	?	2											1?	1	
P 2/58	S	M	2								br	1	2	1	2	
P 2/73	S	M?	1			1					Fe				1	
P 2/39	S	F	1+1?	1	6		x		2	1					1	4
P 2/27	?	F	1			2		x	1							
P 2/52	S	F	1+2*			4		x		1						

Sl. 91: Trakasti fibuli iz grobov 2/58 (1) in 2/27 (2) na Prelogah ter struktura pridakov v grobovih s takimi fibulami na Magdalenski gori. * = drugačen tip. M. = 1:2.

Fig. 91: Band bow fibulae from Graves 2/58 (1) and 2/27 (2) at Preloge, and the structure of goods in the graves with such fibulae at Magdalenska gora. * = other type. Scale = 1:2.

ovratnico, železno rombično pasno spono in pasnim jezičkom. Pokojnica v grobu 2/39 s Prelog pa je imela menda na eni taki fibuli obešeni masivni zapestnici, poleg tega jo je krasilo šest valjastih uhanov, steklena ogrlica, košarast obesek, igla z uvito glavico, priloženi so ji bili tudi štiri vijčki. Ženska, pokopana v grobu 2/52, je imela poleg trakaste fibule še dve certoški vrsti II in V. Dva dobro ohranjena primerka zasledimo še v grobu 2/1–2, o katerem ni znanih podatkov, medtem ko v zvezi z grobom 2/65 Pečnik govori samo o eni lepi fibuli. Dve trakasti fibuli so po navedbah Brattine našli na prsni 180 cm dolgega okostja v grobu 13/136, zraven katerega je ležal železen nož. En par je inventariziran tudi v sklopu groba 13/115, kjer nista omenjeni.

Tovrstne zaponke je Parzinger označil za južnoalpsko varianto trakastih fibul, ki so predstavljale pendant nekoliko drugačni zahodnohalštatski izvedbi v času horizonta 7a.¹⁰²⁶ Nosile so se na območju med rekama Ticino in Savo,¹⁰²⁷ najpogostejše so v Posočju, kjer jih zasledimo v kombinacijah s kačastimi fibulami, z drobno ločno fibulo, pa tudi s certoškimi vrsti I, II in IV.¹⁰²⁸ V svetlucijški nekropoli je zastopanih več primerkov¹⁰²⁹

¹⁰²⁶ Parzinger 1988, T. 144.1: 1; Pare 1989, Abb. 22.

¹⁰²⁷ Nascimbene 2009, 93 ss, Fig. 19, 20, Tab. 7.

¹⁰²⁸ Teržan 1976, sl. 10: 10, 11, 12: 8, 14: 2, 15: 5.

¹⁰²⁹ Teržan/Lo Schiavo/Trampuž-Orel 1984, T. 18A: 1, 56D, 57E: 3, 4, 58B: 1, 58C: 1-4, 63F: 1, 2, 64B: 2, 64D: 1-3, 64E, 65B: 1, 66C: 1, 73A: 1, 2, 102A: 3, 4, 110F: 4, 112G: 2, 145A: 7, 8, 151A: 4, 151B: 1, 2, 155E: 1, 2, 164D: 2, 170F: 1, 180F: 1, 210D: 1, 2, 211C: 2, 216E, 227B: 1, 236A: 1, 241C: 1, 2, 243E: 2, 3, 245D: 3, 4, 252A: 5, 252C: 1, 255A: 1, 270: 1-4, 276C: 15, 16, 283F: 8, 9, 285F: 6.

4.7.7 BAND, LONG-FOOTED AND SMALL BOW FIBULAE

BAND BOW FIBULAE

This fibula type (*Band Bogenfibel*) is characterized by a long, J-shaped foot in cross-section that terminates in a horizontally positioned knob, while the bow is in the shape of a band and angular in profile, with an obligatory disc guard at the transition into the pin (fig. 91: 1, 2).

Twenty fibulae of this type were found at Magdalenska gora.¹⁰²⁵ It is noteworthy that most were found in Tumulus 2 at Preloge. Some were also recorded in Tumulus 13 and one in Tumulus V at Laščik. They were worn by both women and men, as can be inferred from accompanying grave goods (fig. 91). The table that shows the structure of grave groups also reveals that the costume is not uniform and those not from Tumulus 2 are very poor. The richest grave goods were those of the man buried in Grave 2/58; he had a pair of fibulae, two spears, a socketed axe, a knife and a bronze belt clasp with figural decoration. In Grave 2/73, a fibula of this type was found in combination with a child's ribbed bronze torque, an iron rhombic belt clasp and a belt attachment. The deceased in Grave 2/39 from Preloge reportedly had two solid bracelets threaded onto the fibula and was further adorned by six cylindrical earrings, a glass necklace, a basket-shaped pendant, a roll-headed pin, as well as four spindle whorls. The woman buried in

¹⁰²⁵ Hencken 1978, Figs. 134b, 364v; Tecco Hvala/Dular/Kocuvan 2004, 15: 3, 4, 30D: 6, 37A: 14, 15, 40B: 9, 53: 2, 3, 58A: 8, 60A: 2, 104A: 1, 2, 96E: 2, 114A: 2, 3, 152: 20-22.

kot jih premore celotna Dolenjska, kjer se pojavljajo izključno v skeletnih grobovih.¹⁰³⁰ Pobuda zanje je morda prišla iz svetolucijskega kroga, vendar so jih na Dolenjskem vkomponirali v svojo nošo, saj jih zasledimo v standardni kombinaciji s parom narebrenih zapestnic, uhani iz trakaste žice z vzdolžno kaneluro, z drobnimi steklenimi ali jantarnimi jagodami ter z orožjem, česar v svetolucijskih opravah ni.

DOLGONOŽNE FIBULE

V repertoarju fibul z Magdalenske gore nastopajo nekatere oblike dolgonožnih fibul z okrašenim lokom in peresovino na prehodu v iglo (*sl.* 92).¹⁰³¹ Bolj ali manj zanesljive so le tri grobne celote, ki nakazujejo, da so take fibule nosili moški in ženske. Grob 13/44 s Prelog je po podatkih Brattine vseboval železno sulico, nož in šilo, bronast obroček ter posodo. V grobu 2/11 z Voselce je Pečnik našel poleg fibule z mrežasto okrašenim lokom (*sl.* 92: 1) še certoško vrste V ter dve lepi samostrelni fibuli z naprej gledajočo konjsko glavico, pravokotno pasno spono in pasne jezičke. Grobno celoto V/28 z Laščika sestavljata ena trakasta in ena dolgonožna fibula z mrežastim lokom. Tak tip fibule je vključen tudi med pridatke groba VIII/10–11 s Prelog, v katerem so odkrili dve okostji, ki sta ležali drugo vrh drugega; spodnje ni imelo pridatkov, pri vrhnjem pa naj bi bile po Goldbergovih zapiskih najdene dve certoški fibuli ter polomljena votla zapestnica, kar se ne sklada z objavljenim stanjem. Tudi objavljena grobna celota X/55, v kateri nastopa primerek z drugačnim okrasnim motivom na loku (*sl.* 92: 2), ne ustreza Goldbergovemu poročilu.

Z Dolenjske so ohranjeni le redki konteksti, v katerih nastopa fibula z mrežastim lokom.¹⁰³² V gomili pri Rovišču je bila najdena skupaj z železnima sulicama ter paroma narebrenih zapestnic in nanožnic (skupek 1-1883/12); v grobu 13/34 z Brezja pa skupaj z jantarno ogrlico.

V dolgonožnih fibulah z okrašenim lokom je Nascimbenejeva prepoznala dve različici.¹⁰³³ Primerke z enim mrežastim pasom na loku je označila kot

¹⁰³⁰ *Brezje*: Kromer 1959a, T. 35: 9; *Dobrnič*: Parzinger 1988–1989, T. 19: 3, 38: 18; *Libna*: Guštin 1976, T. 14: 4,5; *Novo mesto*: Knez 1986, T. 21: 5; id. 1993, T. 38: 3; *Roje pri Trebelnem*: Dular J. 2003, T. 27: 2; *Rovišče*: *ibid.*, T. 78: 6; *Stična*: Gabrovec et al. 2006, T. 79: 1, 88: 1, 103: 1, 106: 1; *Vače*: Stare F. 1955a, T. 28: 10, 29: 1,6 in neobjavljeni primerki, NHMW inv. št. 6895, 7935, 8159, 14215, 34840; *Zaloka pri Čužnji vasi*: Dular J. 2003, T. 22: 8; morda še fragmenta iz *Kosmatca pri Preski*: Guštin 1974b, T. 13: 17 in z *Velikega Vinjega vrha (Šmarjete)*: Stare V. 1973a, T. 23: 15.

¹⁰³¹ Hencken 1978, Fig. 134a,284b, 345b; Tecco Hvala/Dular/Kocuvan 2004, T. 58A: 7, 79A: 2, 135: 1, 153: 1,2.

¹⁰³² *Brezje*: Kromer 1959a, T. 41: 12; *Dobrnič*: Parzinger 1988–1989, T. 39: 15; *Novo mesto*: Knez 1993, T. 15: 4; *Rovišče*: Dular J. 2003, T. 67: 5.

¹⁰³³ Nascimbene 2009, 116 ss, Fig. 25, 26, Tab. 10.

Grave 2/52 had, beside the band bow fibula, two Certosa fibulae of Types II and V. Two well preserved examples were found in Grave 2/1–2, though no other data is available on the said grave. In connection with Grave 2/65, Pečnik only mentions one beautiful fibula. According to Brattina, two band bow fibulae were found on the chest of a 180cm long skeleton in Grave 13/136, beside which lay an iron knife. Another pair is inventoried, but not mentioned in the report, as part of Grave 13/115.

Fibulae of this type were determined by Parzinger as the South Alpine variant of band bow fibulae (*Südalpine Bandfibeln*), which represented a pendant to a somewhat different west Hallstatt version in Horizon 7a.¹⁰²⁶ They were worn between the rivers Ticino and Sava,¹⁰²⁷ most commonly in the Soča Valley, where they were found in combinations with serpentine fibulae, with a small bow fibula, as well as Certosa fibulae of Types I, II and IV.¹⁰²⁸ The Most na Soči cemetery yielded more examples of band bow fibulae¹⁰²⁹ than the whole of Dolenjska, where they appear in inhumation graves only.¹⁰³⁰ The incentive for these fibulae may have come from the Sveta Lucija circle, but they eventually became an integral part of the Dolenjska costume, since they are found in standard combination with a pair of ribbed bracelets, flat wire earrings with a longitudinal groove, small glass or amber beads and weapons, which is absent in the costume of Sveta Lucija.

LONG-FOOTED FIBULAE

The collection of fibulae from Magdalenska gora includes several forms of long-footed fibulae with a decorated bow and a coiled spring (*fig.* 92).¹⁰³¹ Of their grave groups, only three are more or less reliable. These indicate that they were worn by both men and women. The first, Grave 13/44 from Preloge, contained an iron

¹⁰²⁶ Parzinger 1988, T. 144.1: 1; Pare 1989, Abb. 22.

¹⁰²⁷ Nascimbene 2009, 93 ff, Figs. 19, 20, Tab. 7.

¹⁰²⁸ Teržan 1976, Abb. 10: 10,11, 12: 8, 14: 2, 15: 5.

¹⁰²⁹ Teržan/Lo Schiavo/Trampuž-Orel 1984, T. 18A: 1, 56D, 57E: 3,4, 58B: 1, 58C: 1-4, 63F: 1,2, 64B: 2, 64D: 1-3, 64E, 65B: 1, 66C: 1, 73A: 1,2, 102A: 3,4, 110F: 4, 112G: 2, 145A: 7,8, 151A: 4, 151B: 1,2, 155E: 1,2, 164D: 2, 170F: 1, 180F: 1, 210D: 1,2, 211C: 2, 216E, 227B: 1, 236A: 1, 241C: 1,2, 243E: 2,3, 245D: 3,4, 252A: 5, 252C: 1, 255A: 1, 270: 1-4, 276C: 15,16, 283F: 8,9, 285F: 6.

¹⁰³⁰ *Brezje*: Kromer 1959a, T. 35: 9; *Dobrnič*: Parzinger 1988–1989, T. 19: 3, 38: 18; *Libna*: Guštin 1976, T. 14: 4,5; *Novo mesto*: Knez 1986, T. 21: 5; id. 1993, T. 38: 3; *Roje pri Trebelnem*: Dular J. 2003, T. 27: 2; *Rovišče*: *ibid.*, T. 78: 6; *Stična*: Gabrovec et al. 2006, T. 79: 1, 88: 1, 103: 1, 106: 1; *Vače*: Stare F. 1955a, T. 28: 10, 29: 1,6 and unpublished examples, NHMW Inv. No. 6895, 7935, 8159, 14215, 34840; *Zaloka near Čužnja vas*: Dular J. 2003, T. 22: 8; may be also fragments from *Kosmatec near Preska*: Guštin 1974b, T. 13: 17 and from *Veliki Vinji vrh (Šmarjeta)*: Stare V. 1973a, T. 23: 15.

¹⁰³¹ Hencken 1978, Figs. 134a,284b, 345b; Tecco Hvala/Dular/Kocuvan 2004, T. 58A: 7, 79A: 2, 135: 1, 153: 1,2.

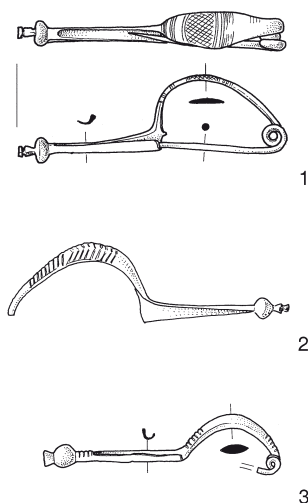

Sl. 92: Dolgonožne fibule z okrašenim lokom. M. = 1:2.
Fig. 92: Long-footed fibulae with a decorated bow. Scale = 1:2.
1 – Voselca, gr. 2/11; 2 – Preloge, gr. X/55; 3 – Preloge, gr. 2/65.

različico I.7A, tiste z dvema mrežastima pasovoma pa kot različico I.7B; obe sta znani tudi z Magdalenske gore. Razširjene so bile v Poadižju, kjer so med drugim zabeležene v depojski najdbi Campo Paraiso; pogoste so v nekropolah ob reki Piavi in v Posočju, najbolj vzhodno pa se pojavljajo prav na dolenjskih najdiščih ter posamična primerka še v Dolnji Dolini in istrskem Nezakciju. Na Mostu na Soči označujejo stopnjo Sv. Lucija IIB, tudi drugod so datirane v zadnjo četrtino 6. in prvo polovico 5. st. pr. n. št. Parzinger jih uvršča med predstavnice horizontov 7b/c in 8a.¹⁰³⁴ Zdi se, da so pripadale ženskim opravam posebnega ranga, kot domneva Nascimbenejeva glede na bronaste situle v grobovih z Mosta na Soči.¹⁰³⁵

Dolgonožna fibula z lokom lečastega preseka, okrašena s snopoma vrezov, je edini tak primerek z Magdalenske gore. Inventarizirana je v sklopu groba 2/65 s Prelog skupaj s še eno trakasto fibulo. Pečnik govori le o eni zelo lepi fibuli, na kateri sta visela dva obeska – eden v obliki človeške glave, nanjo naj bi bili pritrjeni štirje majhni golobčki, drug v obliki petelinčka in dvema jagodama na verižicah. Menda je šlo za otroški grob, v katerem so bile najdene še zelene steklene jagode in uhani, dve majhni narebreni zapestnici, dve votli nanožnici in rdeča posoda. Obeski, ogrlica in ena od nanožnic se niso ohranili. Po Pečnikovem nazornem opisu bi fibulo z obeski lahko primerjali z najdbama iz Paulara¹⁰³⁶ in Podenzoia,¹⁰³⁷ kjer je bilo tako okrasje obešeno na enak tip fibule, kot je prikazan na sl. 92: 3.

spear, a knife and an awl, a bronze ring and a vessel, according to Brattina. In Grave 2/11 at Voselca, Pečnik found a long-footed fibula with reticular decorated bow (fig. 92: 1) together with a Type V Certosa fibula, two beautiful crossbow fibulae with a forward-facing horse head, a rectangular belt clasp and belt attachments. The Grave Group V/28 from Laščik is comprised of one band and one long-footed bow fibula with reticular decoration on the bow. The latter fibula type also formed part of the goods of Grave VIII/10–11 from Preloge, which revealed two skeletons one on top of the other. The lower skeleton was without grave goods, while the upper one was reported by Goldberg to have contained two Certosa fibulae and a broken hollow bracelet. These contents, however, do not correspond to the grave group as published. The publication of Grave Group X/55, with an example with a different decorative motif on the bow (fig. 92: 2), also does not correspond to Goldberg's report.

Only rare contexts that include a fibula with reticular decoration on the bow have been preserved in Dolenjska.¹⁰³² In a tumulus near Rovišče, one such fibula was found together with two iron spears and two pairs of ribbed bracelets and anklets (Group 1-1883/12); while in Grave 13/34 at Brezje it was found together with an amber necklace.

The long-footed fibulae with a decorated bow were divided into two variants by Nascimbene.¹⁰³³ She marked the examples with one reticulated stripe on the bow as Variant I.7A, and those with two such stripes as Variant I.7B. Both were documented at Magdalenska gora. They were widespread in the Adige Valley, where they were also documented among the objects of the Campo Paraiso hoard. They were common in the cemeteries along the river Piave and in the Soča Valley, while the easternmost ones came to light in Dolenjska as well as singly at Donja Dolina and at Istrian Nesactium. They mark the Sv. Lucija IIB phase at Most na Soči. Elsewhere also, they are dated to the last quarter of the sixth and first half of the fifth centuries BC. Parzinger sees them as a representative of Horizons 7b/c and 8a.¹⁰³⁴ It seems that they belonged to the female costume of a particular rank, as supposed by Nascimbene on the basis of bronze situlae in the graves at Most na Soči.¹⁰³⁵

The long-footed fibula with a lenticular cross-section and two stripes of incisions on the bow is the only example of the kind at Magdalenska gora. It is inventoried as part of Grave 2/65 from Preloge together with a band bow fibula. Pečnik speaks of only one very beautiful fibula, on which two pendants were threaded.

¹⁰³² Brezje: Kromer 1959a, T. 41: 12; Dobrnič: Parzinger 1988–1989, T. 39: 15; Novo mesto: Knez 1993, T. 15: 4; Rovišče: Dular J. 2003, T. 67: 5.

¹⁰³³ Nascimbene 2009, 116 ff, Figs. 25, 26, Tab. 10.

¹⁰³⁴ Teržan/Trampuž 1973, 430 f, Fig. 4.2., n. 52; Parzinger 1988, Taf. 145.3; Jablonka 2010, 113, Karte 6.

¹⁰³⁵ Nascimbene 2009, 123.

¹⁰³⁴ Teržan/Trampuž 1973, 430 s, sl. 4.2., op. 52; Parzinger 1988, Taf. 145.3; Jablonka 2010, 113, Karte 6.

¹⁰³⁵ Nascimbene 2009, 123.

¹⁰³⁶ Misincinis, gr. 66: Vitri/Corazza/Simeoni 2007, Fig. 3.

¹⁰³⁷ Nascimbene 2009, 290, T. VIII: 7.

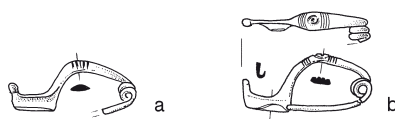

Gom. / gr. Tum. / gr.	Pokop / Burial rite	Spol / starost Sex / Age	Št. fibul / No. of fibulae	Igle / Pins	Uhani / Earrings	Ovratnice / Torques	Steklene jagode / Glass beads	Jantar / Amber	Zapestnice / Bracelets	Lončenina / Pottery
P X/24	S	I	2			1	x		2	
P 2/81	S	I	1+1*	1			2	1	2	
V 2/9	?	F	1+1*		6				2	1
P IV/2	S	F	1+1*		6			x	1	
L V/2	S	F	2+1*	2	6		x	x	4	
P 2/64	S	F	1+1?				x		2	2

Sl. 93: Drobne ločne fibule in struktura pridatkov v grobovih s takimi fibulami na Magdalenski gori. * = drugačen tip. M. = 1:2.

Fig. 93: Small bow fibulae and the structure of goods in the graves with such fibulae at Magdalenska gora. * = other type. Scale = 1:2.

a – Preloge, gr X/24; b – Voselca, gr. 2/9.

DROBNE LOČNE FIBULE

Na Magdalenski gori je zabeleženih tudi 13 primerkov drobnih ločnih fibul z navpično postavljenim pestičastim gumbkom na koncu noge, za katero je značilen J-presek. Lok je okrašen s prečnim snopom vrezom (sl. 93: a) ali dvema pasovoma vrezov ter z vtisnjanim koncentričnim krožcem na sredi (sl. 93: b).¹⁰³⁸

Najdene so bile v otroških in ženskih grobovih (sl. 93). Dve majhni fibuli sta bili najdeni v grobu V/2 na Laščiku pri nogah pokojnice, ki je imela certoško fibulo, zapestnici, iglo in slabo ohranjene uhane. Taka fibula je inventarizirana med pridatki bogatega ženskega groba 13/97 s Prelog, ki pa je Brattina ne omenja. Trije sorodni primerki so znani iz bogatega groba 13/117 v isti gomili, skupaj s še eno drobno certoško fibulo vrste XIII ter čolničasto fibulo s šrafirani pasovi na loku, ki dozdevno ne spada v ta kontekst. O grobu 2/a s Prelog pa Pečnik, Črnologar in Rutar poročajo o štirih ali osmih majhnih fibulah, ki naj bi pripadale nenavadno veliki in bogato opravljeni ženski, vendar grobna celota ni ohranjena, zato ne moremo z gotovostjo reči, da je šlo prav za tovrstne fibule.

Drobne ločne fibule s pestičastim gumbkom je obravnavala Teržanova in jih postavila v čas kačaste

¹⁰³⁸ Hencken 1978, Fig. 18, 103g, 278f, 315b,c; Tecco Hvala/Dular/Kocuvan 2004, T. 57B: 2, 62B: 6, 65B: 9, 100: 16, 105: 29-31, 134B: 7.

One pendant was in the shape of a human head and had four small pigeons attached to it, while the other pendant was in the shape of a cock with two beads on small chains. It was supposedly found in a grave of a child, which further revealed green glass beads and earrings, two small ribbed bracelets, two hollow anklets and a red vessel. The pendants, the necklace and one of the anklets have not been preserved. For the fibula, Pečnik provided a detailed description, which allowed us to compare it with two fibulae from Paularo¹⁰³⁶ and Podenzoio,¹⁰³⁷ respectively, where the adornments are threaded onto the type of fibulae presented on fig. 92: c.

SMALL BOW FIBULAE

Excavations at Magdalenska gora documented 13 examples of small bow fibulae with a vertically positioned pistil-shaped knob at the end of the foot, the latter characteristically J-shaped in cross-section. The bow is decorated either with a stripe of transverse incisions (fig. 93: a) or with two stripes of incisions separated by an impressed concentric circle (fig. 93: b).¹⁰³⁸

These fibulae were found in graves of either children or women (fig. 93). The female in Grave V/2 at Laščik reportedly had four or six poorly preserved earrings, amber and glass beads, a pair of bracelets, a Certosa fibula on her chest and beside them two bracelets and a pin, while at her feet lay a white pebble (amulet?), small red deer bones, numerous multicoloured glass beads and two small fibulae. This type of fibula was inventoried as a grave good of a rich female Grave 13/97 from Preloge, though it is not mentioned by Brattina in his report. Three similar examples are known from rich Grave 13/117 in the same tumulus, found together with a small Type XIII Certosa and a boat fibula with reticulated stripes on the bow, which seems out of context in this grave. In connection with Grave 2/a from Preloge, Pečnik, Črnologar and Rutar report on four or eight small fibulae supposedly belonging to an unusually tall and richly accoutred woman, though the grave group has not been preserved and the fibula type cannot be confirmed.

Small bow fibulae with a pistil-shaped knob were discussed by Teržan, who set them to the time of the Serpentine and early Certosa Fibulae phases.¹⁰³⁹ They are known across the north Adriatic area. At Este, they appear in the early part of Phase III after Frey, but were in use also later. They were known to the Sveta Lucija and Dolenjska communities, some example were even documented in Istria, while none have been found in Notranjska and Bela krajina.

¹⁰³⁶ Misincinis, Gr. 66: Vitri/Corazza/Simeoni 2007, Fig. 3.

¹⁰³⁷ Nascimbene 2009, 290, T. VIII: 7.

¹⁰³⁸ Hencken 1978, Figs. 18, 103g, 278f, 315b,c; Tecco Hvala/Dular/Kocuvan 2004, T. 57B: 2, 62B: 6, 65B: 9, 100: 16, 105: 29-31, 134B: 7.

¹⁰³⁹ Teržan 1976, 318, 344 f, Karte 7.

in zgodnje certoške stopnje.¹⁰³⁹ Znale so na severno-jadranskem območju, v Este se pojavijo v zgodnji fazi stopnje III po Freyu, toda obdržale so se tudi kasneje. Poznali sta jih svetolucijska in dolenjska skupnost, nekaj primerkov je zabeleženih v Istri, medtem ko jih na Notranjskem in v Beli krajini ni.

Z vidika količinske zastopanosti bi lahko trakastim, dolgonožnim in drobnim ločnim fibulam pripisali obrobno vlogo v dolenjski noši, vendar so pomembne priče stikov s svetolucijskim in severnoitalskim prostorom. Dolgonožna fibula iz magdalenskogorskega groba 2/65 s Prelog je po opisu obeskov skoraj zagotovo predstavljala import z območja Poadižja ali Piave. Drobne ločne fibule so nosile deklince in ženske običajno skupaj z raznovrstnimi fibulami, obročastim nakitom in ogrlicami, medtem ko so dolgonožne fibule z mrežastim lokom in navadne trakaste fibule nosili tudi moški. Največ trakastih fibul na Dolenjskem je bilo najdenih na Magdalenski gori v gomili 2 na Prelogah, morda so se člani te družine ukvarjali s trgovanjem.

4.7.8 CERTOŠKE FIBULE

Certoške fibule so zaznamovale nošo mlajšega halštatskega obdobja na Dolenjskem. Poglobljeno jih je obravnavala že Teržanova in po njih predlagala poimenovanje stopnje, ki je sledila kačastim fibulam.¹⁰⁴⁰ Njena tipološko-kronološka študija je široko uveljavljena, zato posameznih oblik ni treba posebej predstavljati. V tem delu bom poskušala osvetliti le kontekste, v katerih nastopajo na Magdalenski gori, in preveriti količinsko zastopanost posameznih vrst znotraj dolenjske halštatske skupnosti.

Prve znanilke nove mode so certoške fibule vrste **II** (sl. 94: 2–6).¹⁰⁴¹ V magdalenskogorskih grobovih največkrat nastopata različici **IIb** in **IIg** (sl. 94: 3, 5), bolj redki so primerki različice **IIc**, ki ima namesto diska dvojno zanko na prehodu v iglo (sl. 94: 6), ter različice s samostrelno peresovino, kakršna je bila najdena v grobu VII/42 s Prelog (sl. 94: 7). Žal so nekatere grobne celote problematične, toda po tistih, ki so zanesljivejše (sl. 95), lahko sodimo, da so jih nosili običajno v paru, sestavljenim iz enakih ali različnih tipov.¹⁰⁴² Zastopane so v kombinacijah z drobno ločno fibulo s pestičastim gumbkom, z navadno trakasto fibulo ter certoškimi vrst I in V, pa tudi s samostrelnimi fibulami (certoško vrste VIb in z vzhodnoalpsko živalsko

¹⁰³⁹ Teržan 1976, 318, 344 s, karta 7.

¹⁰⁴⁰ Teržan 1976.

¹⁰⁴¹ *Ibid.*, 320 ss, sl. 2.

¹⁰⁴² Hencken 1978, Fig. 9c, 21a,b, 37a, 40a, 53a,b, 59b, 67a,b, 103i, 243i, 264a, 304c, 314a,b, 339c,d; Tecco Hvala/Dular/Kocuvan 2004, T. 31C: 2, 40B: 8, 57C: 1,2, 62C: 3,4, 65B: 8, 67B: 1, 70C: 1, 80B: 3, 128: 29, 134B: 8, 139A: 2, 153: 10.

In view of their quantity, band, long-footed and small bow fibulae could be thought to have had a marginal role in the Dolenjska costume. However, they bear an important witness to the contacts with the Sveta Lucija and north Italian areas. The long-footed fibula from Grave 2/65 at Preloge, for example, was almost certainly imported from either the Adige or the Piave basins, if the description of the pendants is anything to go by. The overview above also revealed that small bow fibulae were worn by girls and women, usually together with other types of fibulae, ring jewellery and necklaces, while the long-footed fibulae with reticular decoration and simple band bow fibulae were also worn by men. The highest number of band bow fibulae in Dolenjska was found in Tumulus 2 at Preloge, which suggests that the members of the family were in some way involved in the trade.

4.7.8 CERTOSA FIBULAE

Certosa fibulae mark the costume of the Late Hallstatt period in Dolenjska. They were studied in detail already by Teržan, who also used them to name the phase following that of the Serpentine fibulae.¹⁰⁴⁰ Her typo-chronological study is widely accepted, wherefore individual types need no particular introduction. The discussion here is therefore limited to the presentation of the contexts with Certosa fibulae at Magdalenska gora as well as to a verification of the quantitative representation of individual types in Dolenjska.

The Certosa fibulae of Type **II** (fig. 94: 2–6) were heralds of a new fashion.¹⁰⁴¹ At Magdalenska gora, the most common variants are **IIb** and **IIg** (fig. 94: 3, 5). Occurring less frequently is Variant **IIc**, with a two-coil spring instead of a disc guard at the bow-to-pin transition (fig. 94: 6), but also variants with a crossbow spring, such as was found in Grave VII/42 at Preloge (fig. 94: 7). The more reliable grave groups (fig. 95) reveal that these fibulae were usually worn in pairs made up either of the same or of different types.¹⁰⁴² They appear in combinations with a small bow fibula with a pistil-shaped knob, with a simple band bow fibula, Certosa fibulae of Types I and V, as well as crossbow fibulae (Certosa Type VIb and East Alpine animal-headed fibula). This indicates their long-term use. In male graves, they appear together with a socketed axe, while in female graves they were found together with cylindrical or band earrings, a pair of ribbed bracelets and rarely with hollow ring jewellery.

¹⁰⁴⁰ Teržan 1976.

¹⁰⁴¹ *Ibid.*, 320 ff, Abb. 2.

¹⁰⁴² Hencken 1978, Figs. 9c, 21a,b, 37a, 40a, 53a,b, 59b, 67a,b, 103i, 243i, 264a, 304c, 314a,b, 339c,d; Tecco Hvala/Dular/Kocuvan 2004, T. 31C: 2, 40B: 8, 57C: 1,2, 62C: 3,4, 65B: 8, 67B: 1, 70C: 1, 80B: 3, 128: 29, 134B: 8, 139A: 2, 153: 10.

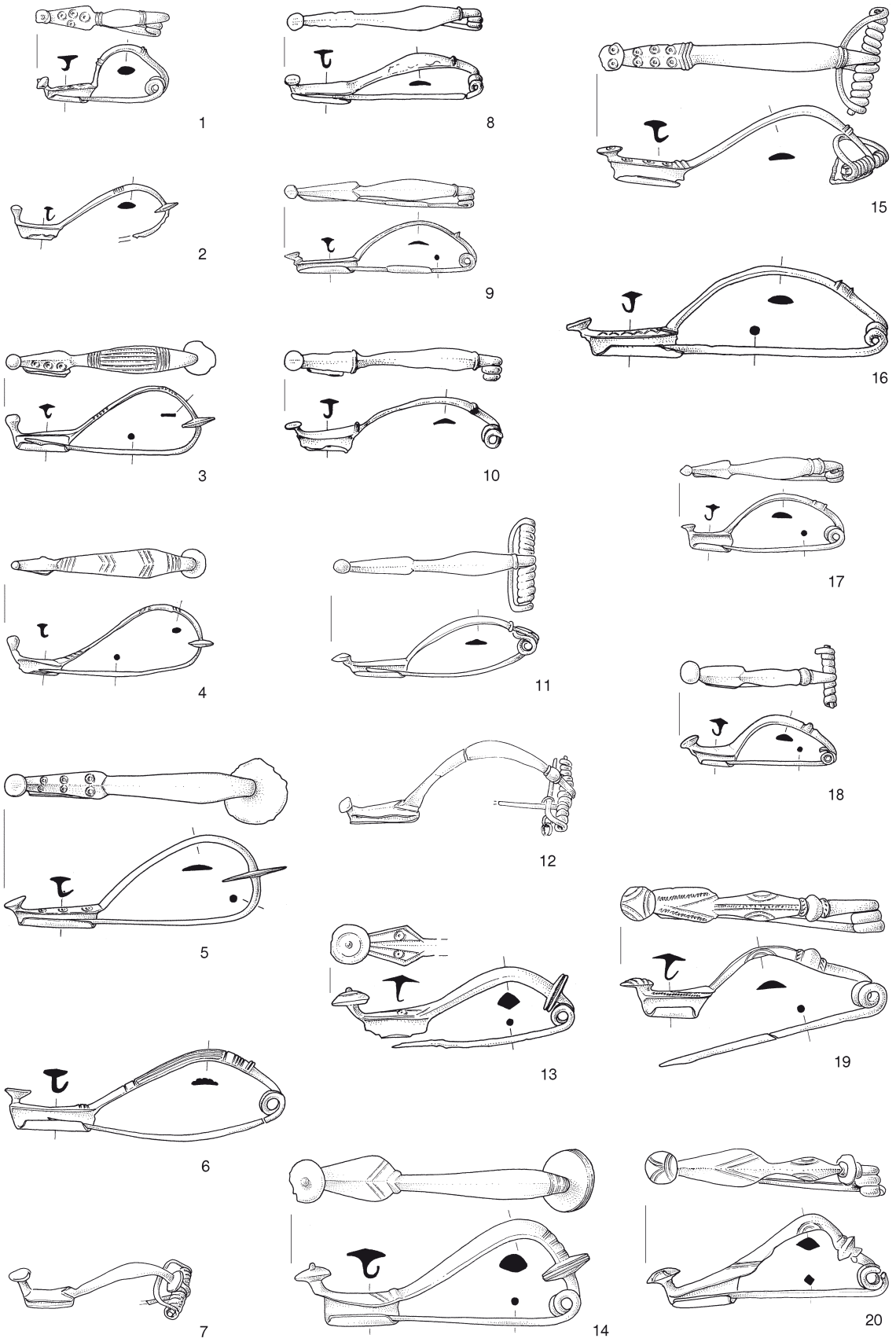

Gom. / gr. Tum. / gr.	Pokop / Burial rite	Spol / starost Sex / Age	Tipi fibul / Types of fibulae	Št. fibul / No. of fibulae	Igle / Pins	Uhani / Earrings	Ovratnice / Torques	Steklene jagode / Glass beads	Jantar / Amber	Zapestnice / Bracelets	Nanožnice / Anklets	Scepter / Sceptre	Pasne sponje / Belts	Pasni okovi / Belt attachments	Sekire / Axes	Sulice / Spears	Noži / Knives	Brus / Whetstone	Lončenina / Pottery	Vijčki / Spindle whorls	
P 2/14	S	M?	Ib	2			1								?	?					
P 13/153	S	M	Ib	1+1*									1	x			1		1		
P X/67	S	I	Ib?	1?+1*	1		x			2											
P 2/83	S	F	IIa	2		2				1											
P X/50	S	F	IIb	2	1					2+1											
V 2/20	?	F		1+1*				x	x	2											
P 2/30	?	I?		1				x	x	1+1											
P 13/49	S	F		1		2			x	2										1	
P IV/2	S	F		1+1*		6			x	1											
P 2/52	S	F	IIb+V	2+1*					x												
P IV/17	S	M	IIb+IIId	2										1	1						
V 2/9	?	F	IIc	1+1*		6				2										1	
P 2/68	?	F	IIId	2		1				2										1	
L V/2	S	F	IIg+Ib	1+1+1*	2	4-6		x	x	2+2											
P II/10	?	?	IIg+IIb	2																	
P 13/18	S	?	IIg+VIb	2																1	
P X/23	S	M	IIg	2										1							
P 13/6	?	?	IIg	1																	
V 2/11	S	M	V	1+3*									br	x			?			2	
P VII/41	S	M		2											x			1			
P X/51	S	M		2										br	x	1	2				
P 13/69	S	A		1				2						br + Fe	x			1			1
V 2/18	S	?		2							2			Fe							
P 13/36	S	F+M?		2		1?	2		x	x	4	2	1	Fe				1	1		2
P 2/17	S	?		1+1*		1												1			
P 2/15	S	F		1							1	2									4
P 2/24	S	F		1			2		x	x											
P 2/53	S	F		1			4			x											
P 2/84	S	F		1			2														1
P 13/54	S	I?		V+VIIb	1+1				1							1					
P 2/60	S	M		VIIa	2									Fe	x	1	1	1			
P 13/79	S	F	VIIc	1						2											
L V/4	S	F	VIIIf	1						2											
P VII/38	S	F		1					x		2										
P 2/72	?	?		1																	1

Sl. 95: Struktura pridatkov v grobovih s certoškimi fibulami na Magdalenski gori. * = drugačen tip.

Fig. 95: Structure of goods in the graves with Certosa fibulae at Magdalenska gora. * = other type.

Sl. 94: Tipi certoških fibul (po Teržanovi) z Magdalenske gore. M. = 1:2.

Fig. 94: Types of Certosa fibulae (after Teržan) from Magdalenska gora. Scale = 1:2.

1 – Preloge, gr. 13/153 (**Ib**); 2 – Preloge, gr. 2/83 (**IIa**); 3 – Preloge, gr. 2/52 (**IIb**); 4 – Preloge, gr. 2/68 (**IIId**);
5 – Preloge, gr. 13/6 (**IIg**); 6 – Voselca, gr. 2/9 (**IIc**); 7 – Preloge, gr. VII/42 (**II**); 8, 10 – najdbi brez znanih grobnih celot v NMS /
finds without preserved grave group in the NMS (**V**); 9, 17 – Preloge, gr. 13/54 (**V**, **VIIb**); 11 – Preloge, gr. VI/34 (**V**);
12 – najdba brez znanih grobnih celot v PM / find without preserved grave group in the PM; 13 – Preloge, gr. 2/1–2 (**XI**);
14 – Preloge, gr. 13/37 (**XIb**); 15 – Preloge, gr. 13/18 (**VIb**); 16 – Preloge, gr. 2/60 (**VIIa**); 18 – Preloge, gr. 13/79 (**VIIc**);
19 – Preloge, gr. 2/72 (**VIIIf**); 20 – Preloge, gr. X/14 (**XII**).

fibulo), s čimer je nakazan širok časovni razpon njihove uporabe. V moških grobovih jih zasledimo skupaj s tula-sto sekiro, v ženskih opravih pa z valjastimi ali trakastimi uhani, s parom narebrenih zapestnic, redkeje z votlim obročastim nakitom.

Na Magdalenski gori srečamo primerke certoških fibul vrste I (sl. 94: 1 in sl. 95) v ženskih (Laščik, gr. V/2), moških (Preloge, gr. 13/153) in nemara tudi otroških opravih (Preloge, gr. 2/14, X/67), nekaj jih je zabeleženih še med najdbami brez znanih kontekstov.¹⁰⁴³ V grobu 13/153 je bila taka fibula najdena skupaj s samostrelno fibulo s pečatno nogo, nožem, bronasto pravokotno pasno spono in pasnimi jezički, ki so atribut moške noše.¹⁰⁴⁴ En primerek je objavljen tudi med pridatki konjenika v gomili V na Laščiku (V/6–7–7a), toda ni zanesljivo, da je spadal k njegovi opravi, saj se grobna celota ne sklada povsem z Goldbergovim opisom. V sklopu grobne celote X/67 s Prelog je objavljena skupaj s kačasto fibulo. O tem grobu Goldberg poroča, da je šlo za otroški pokop, v katerem sta bili dve majhni zapestnici speti s kačasto fibulo, razen tega so našli dva obročka, štiri majhne obeske, dva gumba, nekaj modrih jagod, iglo s kroglasto glavico in menda še eno ločno fibulo. Tudi Pečnikovi poročili o grobni celoti 2/14 s Prelog se razhajata. Po enem naj bi vsebovala par takih fibul, votlo ovratnico, sulično ost, železen obroček in sekiro, v drugem poročilu pa omenja poleg fibul zgolj votlo ovratnico, ki je bila sicer inventarizirana, vendar je danes izgubljena.

Certoške fibule vrste V (sl. 94: 8–10) so v magdalenskogorskih sestavih precej pogoste.¹⁰⁴⁵ Struktura pridatkov v teh sestavih kaže (sl. 95), da so ženske običajno nosile le po eno tako fibulo skupaj s trakastimi ali valjastimi uhani, votlim obročastim nakitom ter jantarnimi in pisanimi steklenimi ogrlicami. Le pokojnica v grobu 2/52 s Prelog je imela tri fibule (trakasto ter certoški vrst II in V). Dve fibuli sta bili najdeni tudi v bogatejšem ženskem grobu 13/36 s Prelog skupaj z nekaterimi moškimi atributi (brus, nožiček in železna rombična spona). K opravi iz groba 2/17 je spadala še ena samostrelna fibula s konjsko glavico na koncu noge, ki je izgubljena. V kombinaciji s takima fibulama ter z eno dolgonožno z mrežastim okrasom na loku jo srečamo v grobu 2/11 z Voselca, medtem ko je bila v grobu 13/54 s Prelog najdena v kombinaciji s certoško fibulo vrste VIIb, gladko ovratnico z uvitima koncema in tulasto sekiro. Zdi se, da so moški nosili tovrstne fibule v parih (sl. 95), opasani so bili z bronastimi in železnimi pasnimi sponami ter podolgovatimi pasnimi jezički z

Graves at Magdalenska gora yielded examples of Certosa fibulae of Type I (fig. 94: 1 and fig. 95) as parts of the female (Laščik, Gr. V/2), male (Preloge, Gr. 13/153) and possibly also children's costume (Preloge, Gr. 2/14, X/67). Some are recorded among the finds without known contexts.¹⁰⁴³ In Grave 13/153, such a fibula was found together with crossbow fibula with a stamped foot (*Fußzierfibel*), a knife, a bronze rectangular belt claps and belt attachments.¹⁰⁴⁴ Such a type of fibula is published among the grave goods of the horseman buried in Tumulus V at Laščik (V/6–7–7a), though the appurtenance of the fibula to the grave is not reliable, since the published grave group does not entirely correspond with Goldberg's notes. Another fibula of the type is published within Grave Group X/67 from Preloge, together with a serpentine fibula. Of this grave, Goldberg reports of a child's burial that contained two small bracelets tied together with a serpentine fibula, as well as two rings, four small pendants, two buttons, several blue beads, spherical-headed pin and presumably a bow fibula. There is inconsistency also between the two reports by Pečnik concerning the goods in Grave 2/14 from Preloge. According to one, it contained a pair of Type I Certosa fibulae, a hollow torque, a spearhead, an iron ring and an axe, while the other report only cites the fibulae and the hollow bracelet. The latter was inventoried, but is now lost.

Certosa fibulae of Type V (fig. 94: 8–10) appear rather frequently in the graves at Magdalenska gora.¹⁰⁴⁵ The structure of their grave goods (fig. 95) shows that women usually wore only one such fibula in combination with band or cylindrical earrings, hollow ring jewellery as well as amber and multicoloured glass necklaces. Only the deceased in Grave 2/52 at Preloge had three fibulae (one band bow and two Certosa of Types II and V). Two fibulae were found in the rich female Grave 13/36 at Preloge together with several male attributes (whetstone, small knife and an iron rhombic belt clasp). The outfit in Grave 2/17 included, besides a Type V Certosa fibula, a crossbow fibula with a horse's head at the end of the foot; the latter is now lost. It appeared in combination with such fibulae as well as a long-footed fibula with reticular decoration on the bow in Grave 2/11 at Voselca, while in Grave 13/54 at Preloge it was found together with a Certosa fibula of Type VIIb, a plain torque with rolled ends and a socketed axe. As for men, it seems that they wore this type of fibulae in pairs (fig. 95), together with bronze or iron belt clasps and oblong belt attachments with rings (Preloge, Gr. VII/41, X/51, Voselca, Gr. 2/11). An exception is Grave

¹⁰⁴³ Hencken 1978, Fig. 103h, 112f, 352g; Tecco Hvala / Dular/Kocuvan 2004, T. 20C: 1,2, 117B: 2, 138: 19, 153: 12-14.

¹⁰⁴⁴ Teržan 1976, sl. 19.

¹⁰⁴⁵ Hencken 1978, Fig. 63a, 112e, 263c,d, 281f, 284a, 304d, 341g,h, 359t; Tecco Hvala/Dular/Kocuvan 2004, T. 20E: 1, 28A: 1, 30A: 8, 40B: 7, 48C: 8, 62E: 3, 77A: 15,16, 82C: 4, 89C: 4, 118: 9,10, 126: 8, 128: 30; 135: 2, 137D: 1,2, T. 153: 11,16-19.

¹⁰⁴³ Hencken 1978, Figs. 103h, 112f, 352g; Tecco Hvala / Dular/Kocuvan 2004, T. 20C: 1,2, 117B: 2, 138: 19, 153: 12-14.

¹⁰⁴⁴ Teržan 1976, Abb. 19.

¹⁰⁴⁵ Hencken 1978, Figs. 63a, 112e, 263c,d, 281f, 284a, 304d, 341g,h, 359t; Tecco Hvala/Dular/Kocuvan 2004, T. 20E: 1, 28A: 1, 30A: 8, 40B: 7, 48C: 8, 62E: 3, 77A: 15,16, 82C: 4, 89C: 4, 118: 9,10, 126: 8, 128: 30; 135: 2, 137D: 1,2, T. 153: 11,16-19.

obročki (Preloge, gr. VII/41, X/51, Voselca, gr. 2/11), medtem ko je v grobu 2/18 z Voselce zabeležena železna rombična spona. Veliko grobnih celot s certoškimi fibulami vrste V ni skladnih s prvotnim seznamom najdb, ki so jih dokumentirali izkopavalci, zato jih v prikazu ne upoštevam.¹⁰⁴⁶

Certoško fibulo vrste VI s samostrelno peresovino (sl. 94: 15) zasledimo med pridatki groba 13/18 s Prelog skupaj s certoško fibulo vrste II,¹⁰⁴⁷ dvojnico ima v grobni celoti X/43 iz Mecklenburške zbirke, ki ni skladna z Goldbergovim opisom, v katerem govori o eni kačasti fibuli, ki je spenjala šest uhanov, ter še eni samostrelni fibuli in bronasti šivanki, objavljeni pa sta dve kačasti ter dve certoški fibuli (vrst VIb in XIII), razen tega osem uhanov in dve šivanki.¹⁰⁴⁸

Široko paleto različic predstavljajo certoške fibule vrste VII (sl. 94: 16–19 in sl. 95).¹⁰⁴⁹ Različico VIIa srečamo v grobu 2/60 s Prelog skupaj s sulično ostjo, tulasto sekuro, nožičkom, pravokotno železno pasno spono in okroglimi okovi z obročki. V grobu 13/54 na Prelogah je bila najdena različica VIIb skupaj s certoško fibulo vrste V na prsni okostja, ki je imelo okoli vratu bronasto gladko ovratnico z uvitima koncema, medtem ko je tulasta sekira po Brattinovem zapisu ležala v zemlji 10 cm nad skeletom. K tej vrsti fibul bi morda lahko pripisali še primerka, ki sta bila najdena v sklopu izkopavanj vojvodinje Mecklenburške, dozdevno v ženskih grobovih II/4 in VII/27 s Prelog skupaj z valjastima uhanoma s trikotnimi obeski in spiralno zapestnico oz. z votlima zapestnicama in modro stekleno ogrlico. Fibulam vrste VII sta podobna primerka s samostrelno peresovino, eden nima znanega konteksta (sl. 94: 12), drugi je zabeležen v grobu 13/79 (sl. 94: 18), kjer je bil najden v prsnem predelu slabo ohranjenega okostja z majhno lobanjo, ki je imelo na rokah dve drobnonarebreni zapestnici z zakovičenima koncema. V tej skupini certoških fibul izstopa masivnejša in bogato okrašena različica VIIf (sl. 94: 19 in sl. 95), ki jo zasledimo v ženskih opravah v kombinaciji z žičnatimi zapestnicami (V/4), ali z jantarno ogrlico in votlima nanožnicama (VII/38), ali pa zgolj z barvano posodo (Preloge, gr. 2/72).¹⁰⁵⁰

V različici VIIf bi lahko videli prototip za certoške fibule vrste XII, ki imajo bolj trikotno shemo in rombičen presek loka (sl. 94: 20). En tak primerek je objavljen v sklopu grobne celote X/14, ki ni povsem skladna s primarnimi viri.¹⁰⁵¹

2/18 at Voselca, where an iron rhombic belt clasp was recorded. A large number of grave groups with Type V Certosa fibulae do not correspond to the original lists of finds as documented by the excavators; these are not considered in the discussion.¹⁰⁴⁶

A Certosa fibula of Type VI with a crossbow spring (fig. 94: 15) was recorded among the goods of Grave 13/18 from Preloge together with a Certosa fibula of Type II.¹⁰⁴⁷ The same type of fibula was found in Grave X/43, now in the Mecklenburg Collection. The published contents of the grave do not correspond to Goldberg's description, which states one serpentine fibula that tied six earrings, as well as one crossbow fibula and a bronze needle; the publication, on the other hand, lists two serpentine and two Certosa fibulae (Types VIb and XIII), eight earrings and two needles.¹⁰⁴⁸

Certosa fibulae of Type VII come in a wide range of variants (fig. 94: 16–19 and fig. 95).¹⁰⁴⁹ Variant VIIa was found in Grave 2/60 at Preloge together with a spearhead, a socketed axe, a small knife, a rectangular belt clasp and round belt fittings with rings. In Grave 13/54 at Preloge, a Variant VIIb fibula was found together with a Type V Certosa fibula on the chest of the skeleton, which also had a plain bronze torque with rolled ends, while a socketed axe was found 10cm above the skeleton, according to Brattina. The Type VII fibulae could further be attributed two examples unearthed during the excavations by the Duchess of Mecklenburg, presumably in female Graves II/4 and VII/27 at Preloge; the former found together with two cylindrical earrings with triangular pendants and a spiral bracelet, and the latter with two hollow bracelets and a blue glass necklace. Similar to Type VII are two examples with a crossbow spring; one without a known context (fig. 94: 12) and the other documented in Grave 13/79 (fig. 94: 18). The latter was found on the chest of a poorly preserved skeleton with a small skull, the arms of which bore two bracelets with thin ribs and riveted ends. Of all the variants of this type, that of VIIf stands out in its great size and rich decoration (fig. 94: 19 and fig. 95). Its examples formed part of the female costume in combination with wire bracelets (V/4), amber necklace and hollow anklets (VII/38), or merely with a painted vessel (Preloge, Gr. 2/72).¹⁰⁵⁰

Variant VIIf could be seen as the prototype for the Certosa fibulae of Type XII with a triangular scheme and a rhombic cross-section of the bow (fig. 94: 20). One such example was published within Grave Group

¹⁰⁴⁶ Laščik, gr. V/6–7–7a; Preloge, gr. IV/25, VIII/6, VIII/10, X/14, X/75.

¹⁰⁴⁷ Tecco Hvala/Dular/Kocuvan 2004, T. 70C: 2.

¹⁰⁴⁸ Hencken 1978, Fig. 334o.

¹⁰⁴⁹ Hencken 1978, Fig. 16c, 36b, 247b, 281h, 322l; Tecco Hvala/Dular/Kocuvan 2004, T. 56: 1,2, 82C: 3, 93A: 2.

¹⁰⁵⁰ Hencken 1978, Fig. 105a, 257a; Tecco Hvala/Dular/Kocuvan 2004, T. 59D: 1.

¹⁰⁵¹ Hencken 1978, 304b.

¹⁰⁴⁶ Laščik, Gr. V/6–7–7a; Preloge, Gr. IV/25, VIII/6, VIII/10, X/14, X/75.

¹⁰⁴⁷ Tecco Hvala/Dular/Kocuvan 2004, T. 70C: 2.

¹⁰⁴⁸ Hencken 1978, Fig. 334o.

¹⁰⁴⁹ Hencken 1978, Figs. 16c, 36b, 247b, 281h, 322l; Tecco Hvala/Dular/Kocuvan 2004, T. 56: 1,2, 82C: 3, 93A: 2.

¹⁰⁵⁰ Hencken 1978, Figs. 105a, 257a; Tecco Hvala/Dular/Kocuvan 2004, T. 59D: 1.

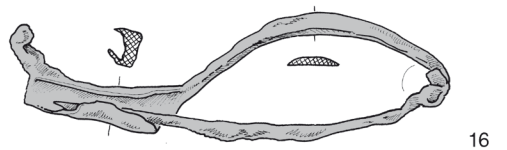
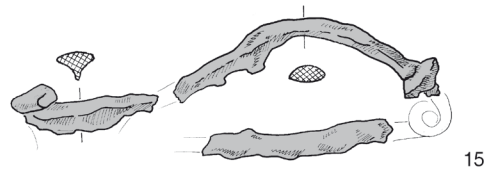
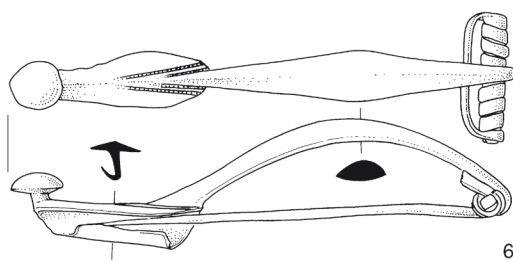
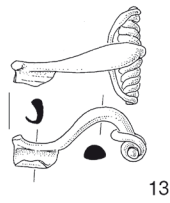
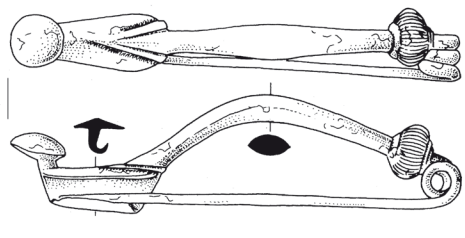
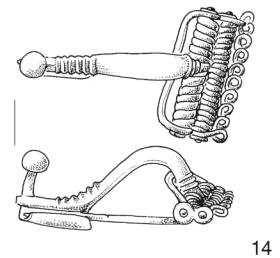
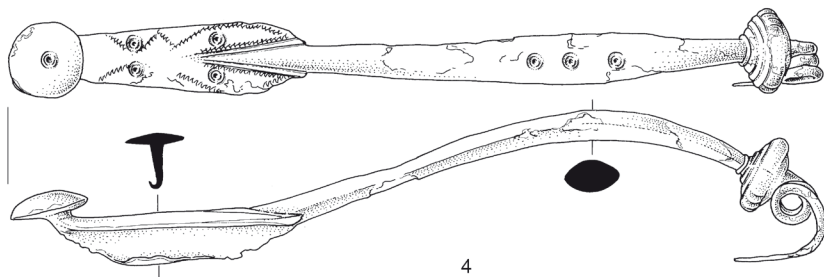
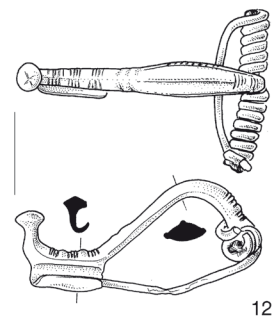
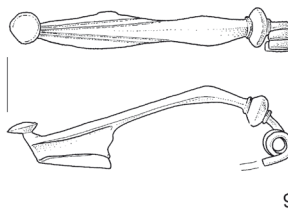
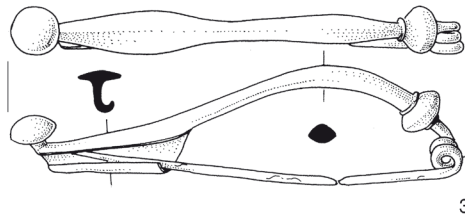
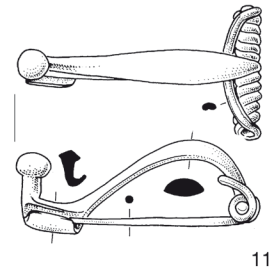
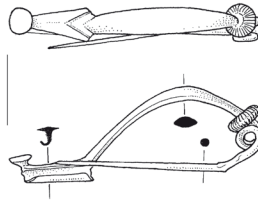
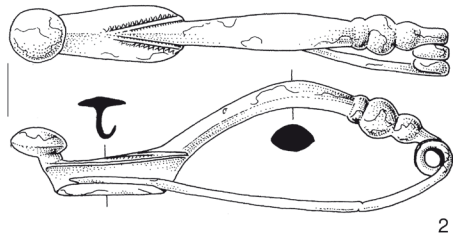
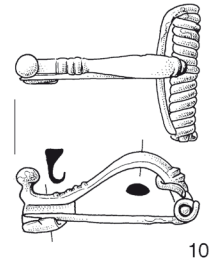
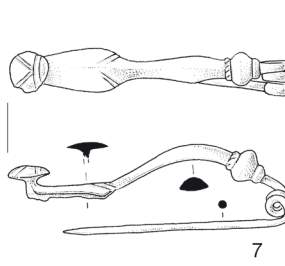
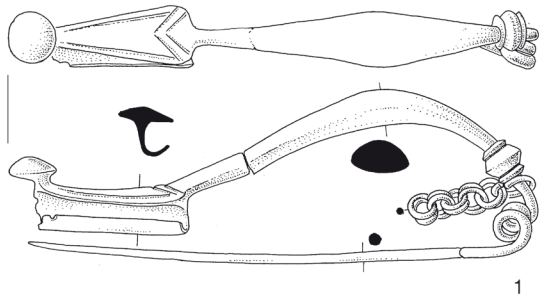

Gom. / gr. Tum. / gr.	Pokop / Burial rite	Spol / starost Sex / Age	Tipi fibul / Types of fibulae	Št. fibul / No. of fibulae	Igle / Pins	Uhani / Earrings	Ovratnice / Torques	Steklene jagode / Glass beads	Jantar / Amber	Au nakit / Au jewellery	Narokvice / Armrings	Nanožnice / Anklets	Pasne sponje / Belts	Pasni okovi / Belt attachments	Obročki / Rings	Čelada / Helmet	Sekire / Axes	Sulice / Spears	Noži / Knives	Žezlo / Mace	Šilo / Awl	Lončemina / Pottery	Koščen tul / Bone tube	Bronasto posodje / Bronze vessels
P X/76	S	M	XIII ?	2									1	x			1	2	1		1			
P 13/57	S	F	XIII ?	2					x		2											1		
P 13/87	S	F	XIII ?	1		1	x	x			2				Fe									
P 13/117	S	F	XIIIa	1+3*	10		x	x	x	2+4	2+2													
P 13/45	S	?	XIIIa	2																		1		
P X/45	S	M	XIIIb	1													1	1						
P X/48	S	?	XIIIb	1+1*																				
P VI/30	S	F	XIII d	1+1*			x	x							br									
P 2/56	?	?		2	1										br									
P 2/4	?	?		2		1																		
P VIII/16	S	M		2													1			?				
P VII/50	S	M		2													1	1						
P 13/55	S	M		2										1	x		1	1	1	1	1		2	2
P 13/53	S	M?		1+1*							1			1	1									
P VI/42	S	?		XIIIb+Xe	2+1						1 Pb													
L V/40	S	?		Xc	2																			
P 13/114	S	A+I		Xc	2		1				2						1							
P 2/25	?	?	Xm	2		1																		
P VII/48	S	F	Xg	1				x																
P VII/13	S	M	Xn+Xg	2+1*												1								
P VII/22	S	?	Xe+Xg	2																				
P X/21a	S	M	Xe+Xg	2						1 Pb						1	2	1						
P 2/3	S	M	Xe	2						1 Pb						1								
P X/64	S	M		1						1 Pb						1+1	1+2	1						
P VII/19	S	M		1						2						1								
P X/32-33	S	M+?		2									1	2		1+1		1						
P VII/44	S	M		2									1	2	br	1								
P 2/5	S	M?		2																				
P II/21	?	?		2																			1	
P X/20	S	M		Xe+XIb	1+1																			
P 13/64	S	M		XIb	1											Fe		1						
P 13/37	S	M			1						2 Pb					Fe		1		1				
P VII/14	S	M	1												Fe			1	1					
P 13/60	S	M	IXb	1												1	1+1	1						
P 13/132	S	M	Fe	1									x	Fe		1	1+1	1						
V 2/23	S	M	Fe	2												1	1							

Sl. 97: Struktura pridatkov v grobovih s certoškimi fibulami na Magdalenski gori. * = drugačen tip.

Fig. 97: Structure of goods in the graves with Certosa fibulae at Magdalenska gora. * = other type.

Sl. 96: Tipi certoških fibul (po Teržanovi) z Magdalenske gore. 1–14 = bron; 15, 16 = železo. M. = 1:2.

Fig. 96: Types of Certosa fibulae (after Teržan) from Magdalenska gora. 1–14 = bronze; 15, 16 = iron. Scale = 1:2.

1–2 (IX), 3–5 (X), 10–12 (XIII) – najdbe brez znanih grobnih celot celot in NMS / finds without preserved grave group in the NMS;

6 – Preloge, gr. 2/10 (Xj); 7 – Preloge, gr. 13/60 (IXb); 8 – Preloge, gr. 13/114 (Xc); 9 – Preloge, gr. 2/25 (Xm);

13 – Preloge, gr. 13/117 (XIIIa); 14 – Preloge, gr. VII/50 (XIII d); 15 – Preloge, gr. 13/132 (Fe); 16 – Voselca, gr. 2/23 (Fe).

Sedmi vrsti certoških fibul so zelo podobni primerki, ki jih je Teržanova označila za vrsto **IX**. Različico **IXb** bi lahko prepoznali v fibuli iz groba 13/60, v katerem so bili še ena daljša in ena krajša sulična ost, uhata sekira in nož s ploščatim nastavkom za koščeni ročaj, ter še v nekaterih drugih primerkih iz nezanesljivih ali neznanih kontekstov (sl. 96: 1, 2, 7).¹⁰⁵²

Med magdalenskogorskimi najdbami so zastopane številne certoške fibule vrste **X**. Naštejemo lahko kar 52 primerkov, ki se razlikujejo po velikosti, oblikovanosti gumba na loku ter po okrasu (sl. 96: 3–6, 8, 9 in sl. 97).¹⁰⁵³ Ohranjeni konteksti kažejo na njihovo koncentracijo v gomilah na Prelogah, po drugi strani pa na pripadnost moški noši, kar potrjujejo tudi antropološke analize, ki so bile opravljene na okostjih iz grobov X/20, X/32–33, X/64 s Prelog.¹⁰⁵⁴ V opravah se s certoškimi fibulami vrste **X** pojavljajo primerki vrst **XI** in **XIII**; zasledimo jih v kombinacijah s tulasto ali plavutasto sekuro, suličnimi ostmi in nožem ter s pravokotno pasno spono ali posnetkom zgodnjelatenskih predrtih spon. Pomembno novost v teh moških opravah predstavljajo zapestnice oz. narokvice, ki so bronaste gladke ali spiralne ali pa svinčene, v grobovih 2/25 in 13/114 s Prelog pa sta bili najdeni tudi votli ovratnici s kroglastimi zaključki. Različici **Xn** in **Xm** (sl. 96: 3, 9) sta značilni za alpsko-lombardijski prostor, medtem ko sta na Dolenjskem redki.¹⁰⁵⁵ Primerki različice **Xn** z Magdalenske gore nima ohranjene grobne celote; različica **Xm** je bila najdena v grobu 2/25 s Prelog skupaj z votlo ovratnico, v grobu VII/13 s Prelog pa skupaj z različico **Xg** in vzhodnoalpsko živalsko fibulo ter tulasto sekuro. Različico **Xj** (sl. 96: 6) bi lahko prepoznali v fibuli s samostrelno peresovino, ki je inventarizirana v sklopu ženskega groba 2/10 s Prelog, ki po drugih pridatkih spada v poznolatenski čas.

Tudi certoške fibule vrste **XI** lahko pripišemo moški noši (sl. 94: 13, 14 in sl. 97).¹⁰⁵⁶ V grobu X/20 nastopa skupaj s fibulo vrste **X**, sicer pa so v glavnem nosili le po eno tako fibulo v kombinaciji s tulasto ali uhato sekuro, sulico in nožem ter s svinčeno narokvico in železnimi obročki.

Moški so pogosto uporabljali tudi certoške fibule vrste **XIII** (sl. 96: 10–14 in sl. 97), ki so jih nosili v paru

¹⁰⁵² Hencken 1978, Fig. 112d; Tecco Hvala/Dular/Kocuvan 2004, T. 87A: 1, 153: 15, 20,21, 154: 11,12.

¹⁰⁵³ Hencken 1978, Fig. 6b, 14, 17d,e, 30b,c, 36c, 71b, 161a,b, 186d,e, 209f, 216d, 232c,d, 238c, 240a,b, 265f, 269b, 295a,b, 308b, 312d,e, 322m,n, 350e; Tecco Hvala/Dular/Kocuvan 2004, T. 17A: 1,2, 19A: 2,3, 20: 2, 30B: 2,3, 103C: 1,2, 126: 11, 153: 22, 154: 1-4,7-10, 155: 1-3.

¹⁰⁵⁴ Pripadnika, pokopana v grobovih X/20 in X/32–33, sta dosegla zrela leta; slednji je bil pokopan skupaj s še eno osebo, katere spol in starost nista bila določena. Tretji član (X/64) je opredeljen kot *adultus iuvenilis*, visok je bil 181 cm. Pripadali so različnim morfološkim tipom po Angelu. Glej tu poglavje 1.1.3, sl. 6.

¹⁰⁵⁵ Teržan 1976, 373, karta 31, pril. 1.

¹⁰⁵⁶ Hencken 1978, Fig. 233g, 308a; Tecco Hvala/Dular/Kocuvan 2004, T. 15: 5,6, 77B: 1, 86D: 1, T. 154: 5,6.

X/14, but its contents do not entirely correspond with the primary sources.¹⁰⁵¹

Very similar to the Certosa fibulae of Type VII are the examples marked by Teržan as Type **IX**. Its variant, namely **IXb**, could be identified in the fibula from Grave 13/60, found together with one long and one short spearhead, a shaft-hole axe and a knife with a flat tang and bone handle. It could further be identified in several other examples from unreliable or unknown contexts (fig. 96: 1, 2, 7).¹⁰⁵²

The Certosa fibulae from Magdalenska gora include as many as 52 examples of Type **X**. They differ in size, shape of the knob on the bow and in decoration (fig. 96: 3–6, 8, 9 and fig. 97).¹⁰⁵³ The preserved contexts reveal their concentration in the tumuli at Preloge, but also that they formed part of the male costume. The latter was confirmed by anthropological analyses performed on the skeletons from Graves X/20, X/32–33, X/64 from Preloge.¹⁰⁵⁴ Appearing together with Type **X** are Types **XI** and **XIII**. As for other graves goods, the fibulae were found in combination with a socketed or winged axe, spearheads and a knife, as well as a rectangular belt clasp or an imitation of the Early La Tène openwork belt hook. An important novelty in these male groups are bracelets or armlets, which are plain or spiral and made of bronze, but also of lead, while Graves 2/25 and 13/114 at Preloge also yielded two hollow torques with spherical terminals. Variants **Xn** and **Xm** (fig. 96: 3, 9) are typical of the Alpine and Lombard areas, while they rarely appear in Dolenjska.¹⁰⁵⁵ The example of Variant **Xn** from Magdalenska gora is without a preserved grave group, while two Variant **Xm** fibulae were found in Grave 2/25 at Preloge together with a hollow torque, and in Grave VII/13 at Preloge together with a Variant **Xg**, an East Alpine animal-headed fibula as well as a socketed axe. The fibula with a crossbow spring inventoried within the female Grave 2/10 from Preloge could be determined as Variant **Xj** (fig. 96: 6), though other goods in the grave rather point to the Late La Tène period.

The Certosa fibulae of Type **XI** could also be attributed to the male costume (fig. 94: 13, 14 and fig. 97).¹⁰⁵⁶

¹⁰⁵¹ Hencken 1978, 304b.

¹⁰⁵² Hencken 1978, Fig. 112d; Tecco Hvala/Dular/Kocuvan 2004, T. 87A: 1, 153: 15, 20,21, 154: 11,12.

¹⁰⁵³ Hencken 1978, Figs. 6b, 14, 17d,e, 30b,c, 36c, 71b, 161a,b, 186d,e, 209f, 216d, 232c,d, 238c, 240a,b, 265f, 269b, 295a,b, 308b, 312d,e, 322m,n, 350e; Tecco Hvala/Dular/Kocuvan 2004, T. 17A: 1,2, 19A: 2,3, 20: 2, 30B: 2,3, 103C: 1,2, 126: 11, 153: 22, 154: 1-4,7-10, 155: 1-3.

¹⁰⁵⁴ The men in Graves X/20 and X/32–33 were mature. The man in the latter grave was buried with another person of undeterminable age and sex. The man buried in Grave X/64 was determined as a 181cm tall *adultus iuvenilis*. According to Angel, they belong to different morphological types. See Chapter 1.1.3, fig. 6.

¹⁰⁵⁵ Teržan 1976, 373, Karte 31, Beil. 1.

¹⁰⁵⁶ Hencken 1978, Figs. 233g, 308a; Tecco Hvala/Dular/Kocuvan 2004, T. 15: 5,6, 77B: 1, 86D: 1, T. 154: 5,6.

različnih ali enakih oblikovnih variant.¹⁰⁵⁷ Kot prikazuje risbe grobov, so spenjale oblačilo na desnem ramenu ali pa na prsih; večkrat so bile povezane z verižico. K tem opravam je običajno spadala pravokotna pasna spona s pasnimi jezički in obročki, tulasta sekira, sulična ost ali dve, včasih tudi nož. Med njimi izstopa poglavar s čelado posebnega tipa (Preloge, gr. 13/55) in žezlom, priložen mu je bil še servis dragocenega posodja (*sl.* 34: A). V grobu 13/53 nastopa v kombinaciji s samostrelno živalsko fibulo s konjsko glavico na zaključku noge ter z bronasto pravokotno pasno spono in gladko zapestnico, medtem ko je bila v grobu VI/42 s Prelog najdena skupaj s svinčeno narokvico in certoško fibulo vrste X. Pokojnik v grobu VII/50 s Prelog je imel par takih fibul z dvojno samostrelno peresovino (*sl.* 96: 14), ta različica se pojavlja v zahodno-balkanskem in podonavskem prostoru v 4. st. pr. n. št.¹⁰⁵⁸ Certoške fibule vrste XIII zasledimo tudi v nekaterih ženskih opravah (*sl.* 97), bodisi posamično ali v paru ter z različnimi drugimi vrstami fibul (drobnimi ločnimi, s samostrelno fibulo z naprej gledajočo konjsko ali ovnovo glavico), z ogrlicami, pa tudi z votlo ovratnico in drugim votlim obročastim nakitom.

Poleg bronastih so na Magdalenski gori zastopani tudi železni primerki (*sl.* 96: 15, 16). En primerek certoške fibule vrste X v železni izvedbi je inventariziran v sklopu grobne celote 13/132 s Prelog, ki vsebuje tulasto sekuro, eno ozkolistno in eno širokolistno sulico, nož s trnastim nastavkom za držaj ter železne obročke z zanko in bronaste pasne okove. Brattina fibule sicer ne omenja, morda je zaradi fragmentiranosti ni prepoznal.¹⁰⁵⁹ V grobu 2/23 z Voselce sta bili najdeni dve železni fibuli s trakastim lokom in enostransko peresovino, kjer nastopata skupaj s tulasto sekuro in sulično ostjo z dolgim tulcem.¹⁰⁶⁰ Ena samostrelna železna fibula pa je objavljena kot pridatek dvojnega groba X/32–33.¹⁰⁶¹ Po Goldbergovih navedbah sta bila skeleta v tem grobu odlično ohranjena,¹⁰⁶² ležala naj bi drug ob drugem v smeri sever–jug; obdajal naj bi ju venec iz kamnov, velikih kot pest ali glava. Eden naj bi imel dve certoški fibuli na levi rami, železno sekuro ob desnem kolenu ter dve 36 cm dolgi sulici pri nogah, razen tega so mu menda pripadali pasni okovi z obročki in fina pasna spona ter košček lesa z drobnimi bronastimi žeblički;

¹⁰⁵⁷ Hencken 1978, Fig. 12a,b, 60, 114c, 127c, 204a, 216c, 223l, 243f,g, 272b, 290b,c, 334l, 336b, 338b, 360k, 361ac; Tecco Hvala/Dular/Kocuvan 2004, T. 15: 7, 18A: 1, 49B: 1,2, 79B: 6,7, 82: 2, 84: 3, 95A: 18, 105: 27, 128: 32, 155: 4-13.

¹⁰⁵⁸ Teržan 1976, 361 s, 380, sl. 30, 50: 2,3, pril. 2.

¹⁰⁵⁹ Tecco Hvala/Dular/Kocuvan 2004, T. 113B: 1.

¹⁰⁶⁰ *Ibid.*, T. 140A: 1,2.

¹⁰⁶¹ Hencken 1978, Fig. 322f.

¹⁰⁶² Angel je enega opredelil kot moškega v zrelih letih, ki ga je uvrstil v svoj morfološki tip B z mešanimi dinarsko mediteranskimi potezami, pri drugem, čigar spol in starost drugega nista določljiva, pa je ugotovil deformacijo vretenc in tibije ter medvretenčno hernijo. Glej tu poglavje 1.1.3 o človeških kostnih ostankih, *sl.* 6.

In Grave X/20, one was found together with a Type X fibula. Predominantly, however, they were worn singly and found together with either a socketed or a shaft-hole axe, a spearhead and a knife, as well as a lead armlet and iron rings.

Men also often wore Certosa fibulae of Type XIII (*fig.* 96: 10–14 and *fig.* 97), in pairs of either the same or of different variants.¹⁰⁵⁷ As discernible from the drawings of graves, they were usually used to fasten clothing on the right shoulder or on the chest. They were sometimes tied with a chain. Usually forming part of the costume was a rectangular belt clasp with attachments and rings, a socketed axe, one or two spearheads, sometimes also a knife. A burial that stands out in this connection is of a chieftain with a special type helmet (Preloge, Gr. 13/55), a mace and a set of precious vessels (*fig.* 34: A). A further fibula of Type XIII was found in Grave 13/53 in combination with a crossbow fibula with a horse's head at the end of the foot, a bronze rectangular belt clasp and a plain bracelet. In Grave VI/42, it was found together with a lead armlet and a Type X Certosa fibula. The male in Grave VII/50 at Preloge had a pair of similar fibulae with a double crossbow spring (*fig.* 96: 14), which is a variant that appears in the western Balkans and the Danube basin in the fourth century BC.¹⁰⁵⁸ The Certosa fibulae of Type XIII could also form part of the female costume (*fig.* 97), appearing in graves either singly or in pairs, and with other types of fibulae (small bow, crossbow with a forward-facing horse's or ram's head), with necklaces, but also a hollow torque and other hollow ring jewellery.

Certosa fibulae are predominantly made of bronze, some also of iron (*fig.* 96: 15, 16). Excavated at Magdalenska gora, one example of an iron Type X Certosa fibula is inventoried within Grave Group 13/132 from Preloge, which further comprised a socketed axe, one narrow- and one broad-bladed spear, a knife with a narrow tang, iron rings with a loop and bronze belt attachments. Brattina makes no mention of the fibula, though it is possible that he did not recognize it due to its poor state of preservation.¹⁰⁵⁹ Grave 2/23 from Voselca revealed two iron fibulae with a band bow and a one-sided spring coil, appearing together with a socketed axe and a spearhead with a long shaft.¹⁰⁶⁰ One iron crossbow fibula was published among the goods from double Grave X/32–33. According to Goldberg, the two skeletons in this grave were excellently preserved,¹⁰⁶¹ lying next to each other with a N–S orientation. They were surrounded by a ring of stones

¹⁰⁵⁷ Hencken 1978, Figs. 12a,b, 60, 114c, 127c, 204a, 216c, 223l, 243f,g, 272b, 290b,c, 334l, 336b, 338b, 360k, 361ac; Tecco Hvala/Dular/Kocuvan 2004, T. 15: 7, 18A: 1, 49B: 1,2, 79B: 6,7, 82: 2, 84: 3, 95A: 18, 105: 27, 128: 32, 155: 4-13.

¹⁰⁵⁸ Teržan 1976, 361 f, 380, Abb. 30, 50: 2,3, Beil. 2.

¹⁰⁵⁹ Tecco Hvala/Dular/Kocuvan 2004, T. 113B: 1.

¹⁰⁶⁰ *Ibid.*, T. 140A: 1,2.

¹⁰⁶¹ Hencken 1978, Fig. 322f.

pri drugem skeletu so menda našli zgolj majhno železno sekuro. Objavljena grobna celota je očitno zamešana, saj je v njej precej več predmetov, med njimi šest različnih fibul, ena bronasta in ena železna predrta pasna spona, tri sulice (a nobena ne ustreza dimenzijam, ki jih navaja Goldberg), medtem ko je sekira samo ena.

Železne fibule z Magdalenske gore imajo dobre paralele v moških grobovih iz Dolenjskih Toplic,¹⁰⁶³ odražajo pa zgodnjelatske vplive, ki so prek severnoitalskega prostora prodrli na Dolenjsko v začetku negovske stopnje.¹⁰⁶⁴

Po pregledu certoških fibul z Magdalenske gore lahko ugotovimo, da predstavljajo absolutno največji delež ($n = 200$), kar priča o svojevrstni moči in bogastvu te skupnosti v najmlajših stopnjah halštatskega obdobja. Velikemu številu primerkov je botrovalo dejstvo, da so jih pogosto nosili v parih in da so razen žensk uporabljali tudi moški.

Kronološki okvir in geografsko širino tega pojava je analitično prikazala in utemeljila že Teržanova.¹⁰⁶⁵ Iz njene analize je razvidno, da spadata vrsti **II** in **V** med najzgodnejši formi, ki sta se pojavili že pred koncem 6. st. pr. n. št. Na Dolenjskem sta bili obe vrsti zelo priljubljeni (sl. 98). Certoške fibule vrste **V** so bile razširjene vse od srednje Italije do Panonije in centralnega Balkana, medtem ko je vrsta **II** najbolj pogosta v svetolucijski in dolenski skupnosti. Sledile so jima različice **Ib**, **VI**, **VIIa** in **IX**, ki v dolenski noši niso doživele širšega razmaha.¹⁰⁶⁶ V 5. st. pr. n. št. se je na Dolenjskem uveljavila moda fibul s samostrelno peresovino (vrsta **XIII** ter živalske in druge oblike fibul s podobno oblikovano peresovino), razen tega so moški pričeli nositi velike certoške fibule vrst **X** in **XI**, ki so se obdržale še vse 4. st. pr. n. št. in ponekod tudi dlje. Fibule vrst **X** in **XI** so bile razširjene od Ligurije do vzhodnega obrobja Alp in severozahodnega Balkana, vendar so med njimi opazne lokalne različice.¹⁰⁶⁷ Različici **Xm** in **Xn**, ki nastopata med najdbami z Magdalenske gore, kažeta na stike s kulturo Golasecca oz. zahodnim svetom, enako velja za železne fibule.¹⁰⁶⁸ Za fibule vrste **XIII** se zdi, da so nastale v svetolucijskem in dolenskem obrniškem krogu, od koder se je ideja razširila v sosednje dežele.¹⁰⁶⁹ Poslednjo izvedbo certoških fibul predstavljajo različice iz vrst **VIIe/f** in **XII**, ki so se pojavile v drugi polovici 4. st. pr. n. št. in se ponekod obdržale še v latenski čas.¹⁰⁷⁰

¹⁰⁶³ Teržan 1976, sl. 56, T. 60: 1,2, 74: 3.

¹⁰⁶⁴ *Ibid.*, 388 s, sl. 57.

¹⁰⁶⁵ *Ibid.*, 348 ss, sl. 16, 18, 43, pril. 1, 2.

¹⁰⁶⁶ *Ibid.*, 354 ss, sl. 20, 22, 25, 26, 44.

¹⁰⁶⁷ *Ibid.*, 357 ss, sl. 31.

¹⁰⁶⁸ *Ibid.*, sl. 52, 57.

¹⁰⁶⁹ *Ibid.*, 362, sl. 30.

¹⁰⁷⁰ *Ibid.*, 371 s, sl. 41, 42; Jablonka 2001, 114, Karte 5.

the size of a fist or a head. One of the skeletons had two Certosa fibulae on the left shoulder, an iron axe beside the right knee, two 36cm long spearheads at the feet and presumably also belt fittings with rings, a fine belt clasp and a piece of wood with small bronze nails. The other skeleton reportedly only had a small iron axe. The grave group, as published, is apparently jumbled up, since it includes many more objects than listed in the excavation notes, among them also six fibulae, one bronze and one iron openwork belt clasp, three spearheads (none of which corresponds to the size stated by Goldberg), while only one axe is listed.¹⁰⁶²

Iron fibulae from Magdalenska gora have close parallels in the male graves from Dolenjske Toplice.¹⁰⁶³ They reflect Early La Tène influences coming to Dolenjska via north Italy at the beginning of the Negova phase.¹⁰⁶⁴

The above overview of the Certosa fibulae from Magdalenska gora reveals that they are by far the best represented kind of fibulae at the site (200 examples), which is evidence of the power and wealth of the community in the last phases of the Hallstatt period. Apart from that, the high number is also due to them often being worn in pairs by both women and men.

The chronological framework and geographic range of Certosa fibulae were analysed and determined already by Teržan.¹⁰⁶⁵ Her analysis reveals that the earliest were Types **II** and **V**, which appeared even before the end of the sixth century BC. In Dolenjska, both types were very popular (fig. 98). Certosa fibulae of Type **V** were spread from central Italy to Pannonia and the central Balkans, while Type **II** was most common in the Sveta Lucija and Dolenjska communities. The two types were succeeded by Variants **Ib**, **VI**, **VIIa** and **IX**, which never really came into vogue in the Dolenjska costume.¹⁰⁶⁶ The fifth century in Dolenjska did, however, witness a vogue for fibulae with a crossbow spring (Type **XIII** as well as zoomorphic and other forms of fibulae with a similar spring). At the same time, men began wearing large Certosa fibulae of Types **X** and **XI**, which remained in use throughout the fourth century BC and at places even longer. The fibulae of Types **X** and **XI** were spread from Liguria to the eastern fringes of the Alps and the north-western Balkans, though they also appear in local

¹⁰⁶² According to Angel, one man was mature of morphological type B with mixed Dinaric-Mediterranean traits. The person of undeterminable sex and age buried with him supposedly suffered of vertebrae and tibia deformations as wells of intervertebral disc herniation. See Chapter 1.1.3 on anthropological remains, fig. 6.

¹⁰⁶³ Teržan 1976, Abb. 56, T. 60: 1,2, 74: 3.

¹⁰⁶⁴ *Ibid.*, 388 f, Abb. 57.

¹⁰⁶⁵ *Ibid.*, 348 ff, Abb. 16, 18, 43, Beil. 1, 2.

¹⁰⁶⁶ *Ibid.*, 354 ff, Abb. 20, 22, 25, 26, 44.

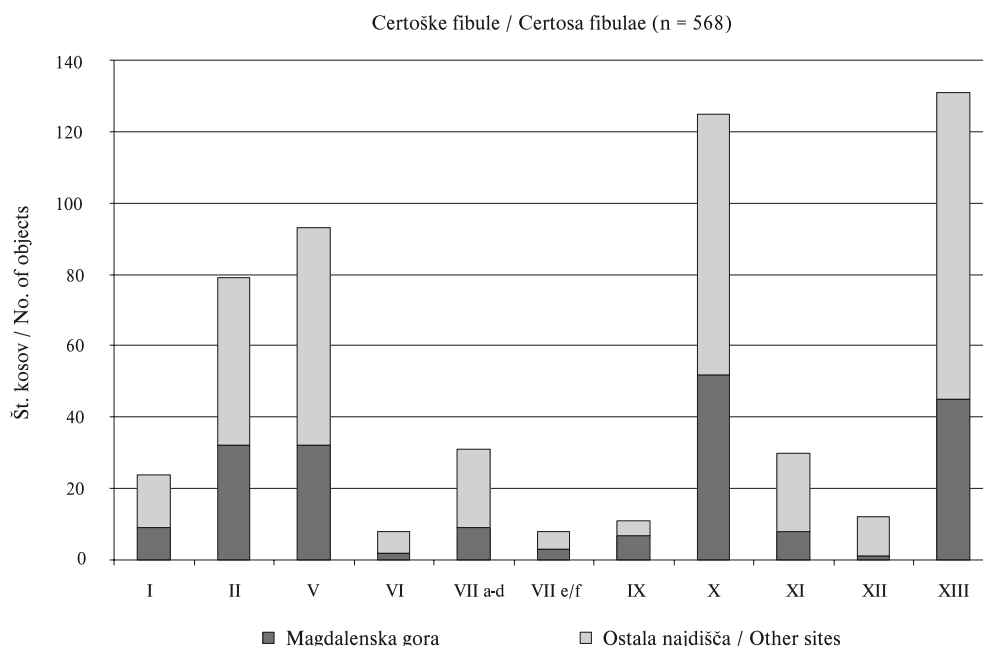

Najdišče Site	Vrste certoških fibul (po Teržanovi) / Types of Certosa fibulae (after Teržan)											Skupaj Total
	I	II	V	VI	VIIa-d	VIIe/f	IX	X	XI	XII	XIII	
Magdalenska gora	9	32	32	2	9	3	7	52	8	1	45	200
Dolenjske Toplice	1		7		9			12	5	1	11	46
Novo mesto	1		11		2			4	1	6	19	44
Vače	3	10	3		3	1	1	6			14	41
Veliki Vinji vrh (Šmarjeta)	1	4	2	1	2	1		5	3		11	30
Stična		6	5					2	1	1	11	26
Valična vas							3	16	2			21
Brezje	6	2			1			4			5	18
Dobrníč		5	3	1	1			3			3	16
Podzemelj			1	1	3			4	2	2	3	16
Mokronog		2	5		1			2			3	13
Boštanj		2	9									11
Libna			6	1				1	2			10
Vinica	1				1	x		x			1	x

Sl. 98: Številčno razmerje med posameznimi tipi certoških fibul v dolenjski skupnosti.
Fig. 98: Quantitative ratio of individual types of Certosa fibulae in the Dolenjska community.

Tipološko-kronološka študija Teržanove o certoških fibulah je predstavljala izhodišče za delitev certoške stopnje na starejšo in mlajšo fazo.¹⁰⁷¹ Tako delitev je v opravah brez orožja nakazala tudi Bergonzijeva v svoji razpravi o jugovzhodnih Alpah in severni Italiji v 5. st. pr. n. št.¹⁰⁷² Prav tako je razvidna iz Parzingerjeve predstavitve značilnih tipov certoških fibul po posameznih časovnih horizontih, pri čemer se je oprl na tipologijo Teržanove. Med vodilne tipe horizonta 7b/c (540/530–510/500 pr. n. št.) je uvrstil certoške fibule vrste II; horizontu 8 (510/500–480/470 pr. n. št.) je pripisal certoške fibule vrste V, horizontu 9 (480/470–450/440

variants.¹⁰⁶⁷ Variants Xm and Xn, for example, which came to light at Magdalenska gora, indicate contacts with the Golasecca culture and the western world; the same holds true for the iron fibulae.¹⁰⁶⁸ The fibulae of Type XIII seemed to have been conceived in the Sveta Lucija and Dolenjska workshops, whence the idea spread into the neighbouring regions.¹⁰⁶⁹ The last Certosa fibulae are those of Variants VIIe/f and XII, which appeared in the second half of the fourth century BC and were, at places, retained into the La Tène period.¹⁰⁷⁰

¹⁰⁷¹ Teržan 1976, 391 ss, pril. 1, sl. 59.

¹⁰⁷² Bergonzi 1981, Tab. A. Glej tu poglavje 2, sl. 10.

¹⁰⁶⁷ *Ibid.*, 357 ff, Abb. 31.

¹⁰⁶⁸ *Ibid.*, Abb. 52, 57.

¹⁰⁶⁹ *Ibid.*, 362, Abb. 30.

¹⁰⁷⁰ *Ibid.*, 371 f, Abb. 41, 42; Jablonka 2001, 114, Karte 5.

pr. n. št.) pa certoške fibule vrste XIII, medtem ko so se v horizontu 10 (450/440–400/390 pr. n. št.) uveljavile certoške fibule vrst VIIc, e, f, g ter X, XI in XII.¹⁰⁷³

Če si ogleđamo razmerja med posamičnimi vrstami in njihovo zastopanost v dolenjski halštatski skupnosti (sl. 98), lahko ugotovimo, da so bile v starejši stopnji najbolj priljubljene zaponke vrst II in V, v mlajši fazi pa vrst X in XIII. Prispevek Magdalenske gore k skupnemu seštevku je presenetljivo velik, saj predstavlja v grobem več kot tretjino vseh certoških fibul s tega območja. Morda je na Magdalenski gori obstajal celo obrtni center, zagotovo pa je spadala med najmočnejša trgovska središča tistega časa v jugovzhodnoalpskem svetu. V njenem repertoarju zasledimo skorajda vse različice, ki so zastopane na Dolenjskem in v Beli krajini. Po pestrosti oblik ji sledi Veliki Vinji vrh oz. Šmarjeta, po količini pa Vače, Dolenjske Toplice in Novo mesto, pri čemer je treba poudariti, da so med najdbami iz novomeških gomil upoštevani le objavljeni primerki.

4.7.9 FIGURALNE IN RAZNE SAMOSTRELNE FIBULE

Med magdalenskogorskimi fibulami so zastopani še razni tipi samostrelnih in figuralnih fibul. Slednje upodabljajo živali, kot so konji, ovni, psi, mačke, ptice ipd., ki so imele v življenju in verovanju železnodobnega človeka poseben pomen, kar potrjuje ikonografija situlske umetnosti, zato bi lahko domnevali, da tudi drugi predmeti s takimi upodobitvami niso imeli zgolj okrasne funkcije.

FIGURALNE FIBULE

Fibule z lokom v obliki mačke in s čepečo ptico ali raco na koncu noge so zastopane s tremi primerki (sl. 99: 1 in sl. 100: A1);¹⁰⁷⁴ eden je bil najden v okviru izkopavanja vojvodinje Mecklenburške v grobu II/15 kot edini pridatek. Enaki fibuli je našel Pečnik v otroškem grobu v gomili 2 na Prelogah (2/o), o katerem je zapisal, da je vseboval poleg dveh ljubkih fibul še eno nanožnico, eno zapestnico in eno ovratnico ter majhne steklene jagode. Grobna celota ni ohranjena.

Tudi fibula z lokom v obliki konjiča in s ptico na koncu noge (sl. 99: 3 in sl. 100: A3) je pripadala otroku, pokopanem v krogu iste družine ali rodu (2/11). K okrasju so spadale še svinčene jagode in ploščati diskasti okraski iz svinca ter obesek v obliki človeške glave, izdelan menda iz zelenega stekla v kombinaciji z rumenimi linijami, ki so izrisovale obraz. Ob odkritju

¹⁰⁷³ Parzinger 1988, Taf. 144.2: 1, 145.2: 3, 147.1: 1,2, 148.1: 1-4.

¹⁰⁷⁴ Hencken 1978, Fig. 25; Tecco Hvala/Dular/Kocuvan 2004, T. 14B: 1,2.

The typo-chronological study on Certosa fibulae by Teržan constituted the basis for a division of the Certosa phase into its early and late subphases.¹⁰⁷¹ Such a division was also indicated by Bergonzi in her discussion on the south-eastern Alps and northern Italy during the fifth century BC.¹⁰⁷² It is furthermore evident from Parzinger's presentation of Certosa fibula types characteristic of individual chronological horizons, which was done using Teržan's typology as basis. The leading types of his Horizon 7b/c (540/530–510/500 BC) include Certosa fibulae of Type II, of Horizon 8 (510/500–480/470 BC) Certosa fibulae of Type V, of Horizon 9 (480/470–450/440 BC) Certosa fibulae of Type XIII, and of Horizon 10 (450/440–400/390 BC) Certosa fibulae of Variants VIIc, e, f, g and Types X, XI and XII.¹⁰⁷³

The ratios between individual types and their representation in the costume of the Dolenjska community (fig. 98) reveals that the most popular Certosa fibulae in the early phase were those of Types II and V, while in the late phase the vogue was for Types X and XIII. The contribution of Magdalenska gora to the sum total is surprisingly great and represents roughly a third of all the Certosa fibulae found in Dolenjska. In light of that, there might even have been a production centre for these fibulae at the site. Magdalenska gora was certainly among the most important trading centres of the time in the south-eastern Alps. Its variety of Certosa fibulae includes almost all of the types present in Dolenjska and Bela krajina. In variety of forms, the site is followed by Veliki Vinji vrh (Šmarjeta), while in quantity it is followed by Vače, Dolenjske Toplice and Novo mesto. Of the finds from the tumuli at Novo mesto, it has to be emphasized that the observation above only takes into account the published examples.

4.7.9 FIGURAL AND VARIOUS CROSSBOW FIBULAE

The fibulae from Magdalenska gora include various types of crossbow (*Armbrustfibeln*) and figural examples. The latter depict animals such as horses, rams, dogs, cats, birds and others, which had a special significance in the life and the beliefs of the Iron Age population. This is confirmed by the iconography of the situla art. Hence, we may conclude that the figural fibula had more than simply a decorative function.

FIGURAL FIBULAE

Three such fibulae, with the bow in the shape of a cat and with either a bird or a duck perched at the

¹⁰⁷¹ Teržan 1976, 391 ff, Beil. 1, Abb. 59.

¹⁰⁷² Bergonzi 1981, Tab. A. See here Chapter 2, fig. 10.

¹⁰⁷³ Parzinger 1988, Taf. 144.2: 1, 145.2: 3, 147.1: 1,2, 148.1: 1-4.

so v Izvestjih Muzejskega društva za Kranjsko takrat zapisali: “Na drugem kraju je našel gosp. Pečnik otroški grob in lepo fibulo s konjičkom. Zraven fibule je bila človeška glavica iz stekla, krasno delo, s katerim se bode ponašal dvorni muzej na Dunaju, kamor gosp. Pečnik (žalibog!) zadnji čas pošilja vse izkopine Kranjske.”¹⁰⁷⁵ Ta enkratna jagoda je očitno res prispela v dunajski muzej, kjer so jo inventarizirali, vendar se je pozneje za njo izgubila sled.

Fibula z upodobitvijo moža na dvokolesnem vozu s konjsko trovprego in ptico z razprtimi krili na koncu noge, t. i. *Kriegerwagenfibel* (sl. 99: 2 in sl. 100: A2), je krasila deklico, staro po Pečnikovi oceni od osem do deset let (Preloge, gr. 2/c).¹⁰⁷⁶ Njena oprava ni ohranjena kot celota, identificirali smo lahko le nekaj predmetov (ježevko iz turkiznega stekla s samostrelno peresovino ter stekleno ogrlico), medtem ko se jantarno okrasje, obročasti nakit in scepter skrivajo med tipološko urejenimi najdbami v zbirki ljubljanskega muzeja.

Figuralne fibule z območja jugovzhodnih Alp je zbral in razčlenil Guštin ter podobno kot Gabrovec ugotavljal, da je idejne vzore za fibule v obliki trig, ovna, konjička, mačke in psička treba iskati v prototipih iz 7. st. pr. n. št. v Italiji, ki so jih posnemali v jugovzhodnoalpskih delavnicah.¹⁰⁷⁷

Fibule v obliki mačke imajo enojno peresovino; znane so z več dolenskih najdišč, kjer nastopajo v otroški in ženski noši skupaj z masivnimi narebrenimi bronastimi zapestnicami.¹⁰⁷⁸ Nascimbenejeva jih je uvrstila v vzhodnoalpsko oblikovno zakladnico in jih opredelila kot varianto C-fibul z lokom v obliki mačke.¹⁰⁷⁹ Fibula z lokom v obliki konjička in s samostrelno peresovino, najdena na Magdalenski gori v otroškem grobu 2/11 s Prelog, predstavlja unikatni izdelek v dolenski halštatski skupnosti, enako kot svinčeni obeski v obliki diskastih ploščic z motivom dvojne spirale. Ta fibula je še najbolj sorodna primerkom iz alpskih najdišč Mechel in Meran-Hochbühel ter panonskega Ikevárja-Pinkóci,¹⁰⁸⁰ medtem ko so svinčeni okraski podobni bronastima obeskom na fibuli z jantarno oblogo iz Este ali pa svinčnim aplikam iz Brega / Fröga, ki so datirani na začetek 6. st. pr. n. št.¹⁰⁸¹

¹⁰⁷⁵ *Izvestja Muzejskega društva za Kranjsko* 3, 1893, 160; Tecco Hvala/Dular/Kocuvan 2004, 34, T. 20B: 7.

¹⁰⁷⁶ Tecco Hvala/Dular/Kocuvan 2004, T. 10A: 2.

¹⁰⁷⁷ Gabrovec 1966b, 28 ss; Guštin 1974b, 95 ss, sl. 1, 2; Teržan 1990a, 100, karta 17; Adam 1996, 97 ss; Metzner-Nebelsick 2007.

¹⁰⁷⁸ Guštin 1976, T. 28: 15, 68: 23,27; Knez 1986, T. 5: 7; Dular A. 1991, T. 27: 6,7.

¹⁰⁷⁹ Nascimbene 2009, 160 ss, Fig. 45, 46.

¹⁰⁸⁰ Lunz 1974, 134, T. 40: 5, 84B; Adam 1996, 100 ss, Fig. 15; Metzner-Nebelsick 2007, Abb. 7: 7,9; Nagy 2011, 166 ss, sl. 104.

¹⁰⁸¹ *Breg / Frög, gr. 168/1*: Tomedi 2002, 263, Abb. 42: 18, T. 81: 21; *Este-Villa Benvenuti, gr. 79*: Calzavara Capuis/Chieco Bianchi 2006, 126 ss, T. 55: 35.

end of the foot (*fig. 99: 1* and *fig. 100: A1*) were found at Magdalenska gora.¹⁰⁷⁴ One was found during the excavations by the Duchess as the sole good in Grave II/15. The other two fibulae were found by Pečnik in a child's grave in Tumulus 2 at Preloge (2/o). Of this grave, Pečnik listed two “lovely” fibulae, an anklet, a bracelet, a torque and small glass beads; the grave group has not been preserved.

The fibula with the horse-shaped bow and a bird at the end of the foot (*fig. 99: 3* and *fig. 100: A3*) also belonged to a child, buried within the same tumulus (2/11). Her adornments further consisted of lead beads and flat, disc-shaped ornaments also made of lead, as well as a pendant in the shape of a human head, reportedly made of green glass in combination with yellow lines that traced the features of the face. Upon discovery, it was written in *Izvestja Muzejskega društva za Kranjsko* that Pečnik, who excavated the grave, sent this unique pendant to the museum in Vienna.¹⁰⁷⁵ As evidenced by the record of it in the inventory book, the pendant was received by the museum. Later, however, it disappeared without a trace.

The fibula with the depiction of a man riding a two-wheeled chariot pulled by three horses and with a bird with outspread wings at the end of the foot (*fig. 99: 2* and *fig. 100: A2*), adorned a girl, aged eight to ten in Pečnik's estimate (Preloge, Gr. 2/c).¹⁰⁷⁶ The grave group has not been preserved; we were only able to identify some of the items (fibula with a turquoise glass overlay with spikes and crossbow spring, glass necklace), while the amber adornments, ring jewellery and sceptre are to be sought within the typologically arranged collection of the museum in Ljubljana.

Figural fibulae from the south-eastern Alps were collected and analysed by Guštin. Similarly as Gabrovec before him, Guštin observed that the idea behind the fibulae in the shapes of three-horse chariots, rams, horses, cats and dogs must be sought in the seventh-century Italic prototypes that served as models to the workshops in the south-eastern Alps.¹⁰⁷⁷

The fibulae in the shape of a cat have a single-coil spring. They were found at several sites in Dolenjska and formed part of the children's or female costume together with solid ribbed bracelets made of bronze.¹⁰⁷⁸ Nascimbene saw them as East Alpine forms and determined them as a variant of the C-fibulae with a cat-shaped

¹⁰⁷⁴ Hencken 1978, Fig. 25; Tecco Hvala/Dular/Kocuvan 2004, T. 14B: 1,2.

¹⁰⁷⁵ *Izvestja Muzejskega društva za Kranjsko* 3, 1893, 160; Tecco Hvala/Dular/Kocuvan 2004, 34, T. 20B: 7.

¹⁰⁷⁶ Tecco Hvala/Dular/Kocuvan 2004, T. 10A: 2.

¹⁰⁷⁷ Gabrovec 1966b, 28 ff; Guštin 1974b, 95 ff, Abb. 1, 2; Teržan 1990a, 100, map 17; Adam 1996, 97 ff; Metzner-Nebelsick 2007.

¹⁰⁷⁸ Guštin 1976, T. 28: 15, 68: 23,27; Knez 1986, T. 5: 7; Dular A. 1991, T. 27: 6,7.



1

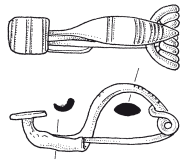

7

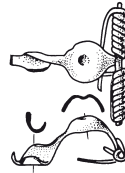

13

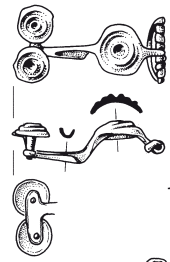

16

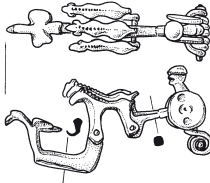

2

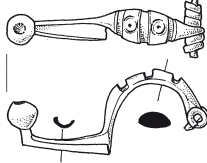

8

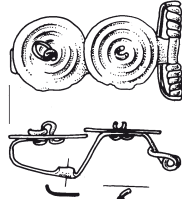

14

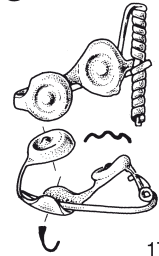

17

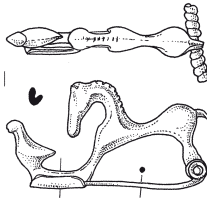

3

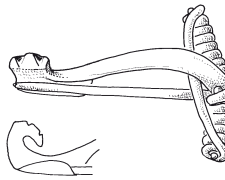

9

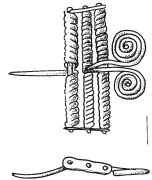

15

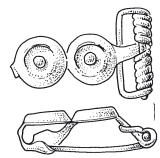

18

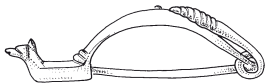

4

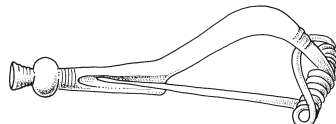

10

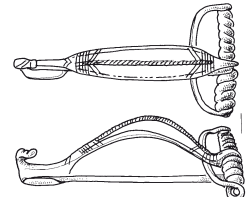

19

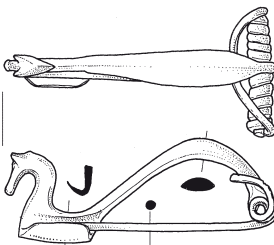

5

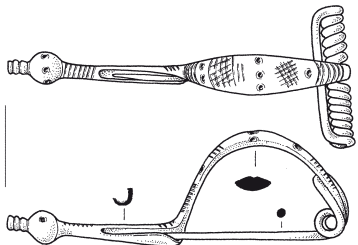

11

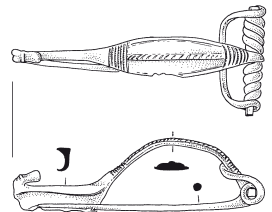

20

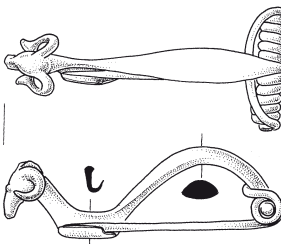

6

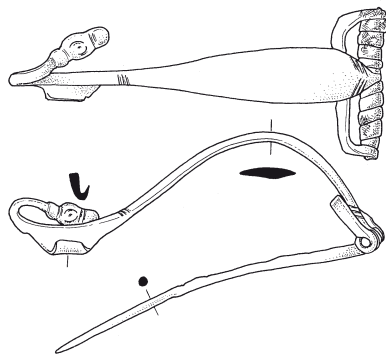

12

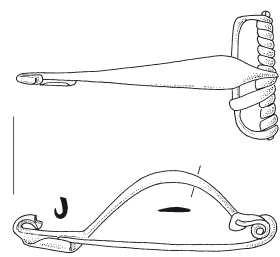

21

Gom. / gr. Tum. / gr.	Pokop / Burial rite	Spol / starost Sex / Age	Tipi fibul / Types of fibulae	Št. fibul / No. of fibulae	Igle / Pins	Uhani / Earrings	Ovratnice / Torques	Steklene jagode / Glass beads	Jantar / Amber	Obeski / Pendants	Zapestnice / Bracelets	Nanožnice / Anklets	Scepter / Sceptre	Pasne spone / Belts	Pasni okovi / Belt attachments	Sekire / Axes	Sulice / Spears	Noži / Knives	Raženj / Spit	Lončenina / Pottery	Vijčki / Spindle whorls	Bronasto posodje / Bronze vessels
P II/15	?	?	A1	1																		
P 2/o	S	I	A1	2																		
P 2/c	S	I	A2	1+2*		2		x	x		1	1									3	
P 2/11	S	I	A3	1						x												
L V/43	S	?		1																		
P IV/30a	S	F		1		2																
P 13/150	S	?	A5	2																	1	
V 2/11	S	M?		2+2*										1	x						2	
P 2/17	S	?		1+1*	1													1?				
P VI/34	S	F	A5?	1+1*					x		2											
P VIII/4	S	I?	A5?	1			1	x			2		1								1	
P 2/b	S	M	A6	2												2			Fe			1
V 2/21	?	F	A7	1+1*		x		x	x		2											
V 2/20	?	F	A7?	1+1*					x		2											
P 2/40	?	F	A7?	1					x		2											
V 2/17	?	F		1					x		2											
P X/36	S	F+?		1				x	x		2			4		1						
P 13/65	S	I		1				x	x		2										1	
P VI/33a	?	I	A8	1							2+1											
P VI/8	S	F		1					x		3											
L V/36	S	F		1		2			x		2											
P IV/19	?	F		1		4																
P 2/80	S	F	A10	1							2?											
P 13/153	S	M	B1	1+1*										1	x			1		1		
P 2/55	S	I	B2	1			1	1			1											
L V/37	S	F	B3?	1				x	x	x	2											
P 13/116	S	F+?	B3	1																5	2	
L V/30	S	M	D1	2												1						

Sl. 100: Struktura pridakov v grobovih s figuralnimi in samostrelnimi fibulami na Magdalenski gori.

Fig. 100: Structure of goods in the graves with figural and crossbow fibulae at Magdalenska gora.

A1 = sl. / fig. 99: 1; A2 = sl. / fig. 99: 2; A3 = sl. / fig. 99: 3; A5 = sl. / fig. 99: 5; A6 = sl. / fig. 99: 6; A7 = sl. / fig. 99: 21;
A8 = sl. / fig. 99: 19,20; A10 = sl. / fig. 99: 12; B1 = sl. / fig. 99: 7; B2 = sl. / fig. 99: 8; B3 = sl. / fig. 99: 11; D1 = sl. / fig. 99: 15;
* = drugačen tip / other type.

Sl. 99: Figuralne in razne samostrelne fibule z Magdalenske gore. M. = 1:2.

Fig. 99: Figural and various crossbow fibulae from Magdalenska gora. Scale = 1:2.

1 – Preloge, gr. 2/o; 2 – Preloge, gr. 2/c; 3 – Preloge, gr. 2/11; 4 – Preloge, gr. X/50; 5 – Voselca, gr. 2/11; 6 – Preloge, gr. 2/b;
7 – Preloge, gr. 13/153; 8 – Preloge, gr. 2/55; 9 – Preloge, gr. IV/38; 10 – Laščik, Tum V; 11 – Preloge, gr. 13/116; 12 – Preloge,
gr. 2/80; 13, 14, 16, 17 – najdbe brez znanih grobnih celot v NMS / finds without preserved grave group in the NMS;
15 – Laščik, gr. V/30; 18 – Preloge, gr. IV/41; 19 – Preloge, gr. IV/19; 20 – Preloge, gr. 13/65; 21 – Voselca, gr. 2/21.

Svojevrstno simboliko izražajo fibule, ki naj bi upodabljale moško figuro na bojnem vozu s konjsko vprego in ptico v letu na koncu noge.¹⁰⁸² Primerke z območja vzhodnih Alp je nazadnje analizirala Nascimbenejeva in na osnovi znanih grobnih celot pokazala, da so spadale v ženske oz. dekliške oprave, kar je v navideznem nasprotju z vojaškim motivom, ki naj bi ga upodabljale.¹⁰⁸³ Najbrž se v tej ikonografiji skriva globlje simbolno sporočilo, ki je povezano s kultno sfero,¹⁰⁸⁴ kar neposredno potrjuje tudi najdba iz Clesa, ki je morda predstavljala votivni dar, odkrita je bila namreč v okviru kulturnega mesta Campi Neri. V dolensko-belokranjski regiji so fibule s takim ikonografskim motivom zabeležene v izjemnih dekliških oz. ženskih opravah s sceprom (Magdalenska gora) ali z množico obročastega, jantarnega in steklenega okrasja (Vače, Vinica).¹⁰⁸⁵ Datirali bi jih lahko v certoško stopnjo, glede na to, da imajo samostrelno peresovino, ki se na tem prostoru ne pojavi pred certoško stopnjo,¹⁰⁸⁶ pa tudi po obliki steklenih jagod iz magdalenskogorskega groba 2/c.

Bolj številne so fibule, ki imajo na zaključku noge konjsko, ovno ali pasjo glavico, obrnjeno s pogledom v nasprotno smer od loka (*sl.* 99: 4–6 in *sl.* 100: A5, A6), po osnovni shemi pa so podobne certoškimi fibulam vrste XIII. Primerka s pasjo glavico nimata znanega oz. zanesljivega konteksta – eden je zabeležen v sklopu najdb iz gomile 13 na Prelogah, drugi je vključen v grobno celoto X/50 s Prelog iz Mecklenburške zbirke, ki ni skladna z Goldbergovim popisom.¹⁰⁸⁷ Pogosteje je zaključek noge oblikovan v konjsko glavico. V grobu 13/150 s Prelog sta bili najdeni dve taki fibuli, povezani z verižico, vendar je ohranjena le ena; med pridanke je spadala še nagubana skleda na nogi. Primerka iz voselškega groba 2/11

¹⁰⁸² Lunz 1974, 139, T. 92B; Guštin 1974b, 96 ss, sl. 1; Adam 1996, 102 ss, Fig. 16.

¹⁰⁸³ Nascimbene 2009, 168 ss, Fig. 49, 59, T. 21, 22.

¹⁰⁸⁴ Morda bi v tem motivu lahko prepoznali Helijev voz s sončnimi konji oz. upodobitev legende o njegovem nesrečnem sinu Faentonu (Phaeton), ki ni znal obvladati v sončni voz vpreženih konj na poti po nebesnem svodu in je, zadet od Zevsove strele, zgrmel v reko Eridan (= Pad). Faentontove sestre Heliade, spremenjene v topole, so objokovale njegovo smrt točile jantarne solze, za njim je žaloval tudi njegov sorodnik, ligurski kralj Kiknos, ki se je v žalosti spremenil v laboda (Grilli 1991, 17 s; Mastrocinque 1991, 11 ss; Palavestra 1993, 5 s; Šašel Kos 1999, 10; ead. 2005, 116 s; Palavestra/Krstić 2006, 22). Fibula upodablja vse bistvene komponente te mitološke zgodbe – voz, konje, moško figuro, laboda (ptica v letu na zaključku noge ima dolg vrat, zato bi nemara lahko predstavljala laboda, sicer pa je ptica z razprtimi krili značilen grško-italski motiv). Razen tega se v opravi umrle deklice omenja tudi jantarno okrasje in kultna palica. Kasnejše upodobitve tega ikonografskega motiva so znane z rimskih sarkofagov iz 2. in 3. st. na območju severne in srednje Italije (Mastrocinque 1991, Fig. 1–4).

¹⁰⁸⁵ Mahr (ur.) 1934, 106, 121, T. 21: 113, 29: 140.

¹⁰⁸⁶ Gabrovec 1966b, 29 s.

¹⁰⁸⁷ Hencken 1978, Fig. 339a; Tecco Hvala/Dular/Kocuvan 2004, T. 126: 6.

bow.¹⁰⁷⁹ The fibula with a horse-shaped bow and a crossbow spring, found in child's Grave 2/11 at Preloge, represents a unique item within the Dolenska Hallstatt community, similarly as the lead disc-shaped pendants with a double spiral motif. This fibula is most similar to the examples from Mechel and Meran-Hochbühel in the Alps and Ikevár-Pinkóci in Pannonia,¹⁰⁸⁰ while the lead pendants resemble the bronze pendants on a fibula with an amber overlay from Este or lead appliqués from Frög, dated to the beginning of the sixth century BC.¹⁰⁸¹

The fibulae interpreted as depicting a male figure on a horse-drawn war chariot on the bow and a bird in flight positioned at the end of the foot (*Kriegerwagenfibel*) certainly carry a symbolic meaning.¹⁰⁸² The examples of such fibulae from the area of the eastern Alps were last analysed by Nascimbene. On the basis of known grave groups, she showed that the fibulae formed part of the girls' or women's costume, which is in seeming contradiction to the warrior motif they supposedly depicted.¹⁰⁸³ The symbolic meaning behind this iconography is probably tied to the cult sphere,¹⁰⁸⁴ which is indirectly confirmed by the find from Cles. The latter may have been a votive offering, as can be inferred from the findspot within the cult place at Campi Neri. In Dolenska and Bela krajina, fibulae with such a motif were documented within exceptional grave groups of either women or girls that include a sceptre (Magdalenska gora) or a multitude of ring, amber and glass jewellery

¹⁰⁷⁹ Nascimbene 2009, 160 ff, Figs. 45, 46.

¹⁰⁸⁰ Lunz 1974, 134, T. 40: 5, 84B; Adam 1996, 100 ff, Fig. 15; Metzner-Nebelsick 2007, Abb. 7: 7,9; Nagy 2011, 166 ff, Abb. 104.

¹⁰⁸¹ Frög, *Gr.* 168/1: Tomedi 2002, 263, Abb. 42: 18, T. 81: 21; *Este-Villa Benvenuti*, *Gr.* 79: Calzavara Capuis/Chieco Bianchi 2006, 126 ff, T. 55: 35.

¹⁰⁸² Lunz 1974, 139, T. 92B; Guštin 1974b, 96 ff, Abb. 1; Adam 1996, 102 ff, Fig. 16.

¹⁰⁸³ Nascimbene 2009, 168 ff, Figs. 49, 59, T. 21, 22.

¹⁰⁸⁴ The motif might represent Helios' chariot drawn by fiery horses and thus depict the legend of his ill-fated son Phaeton. The latter insisted on driving the sun chariot but was unable to control the horses on the journey across the sky. He was eventually stopped by Zeus, who struck him with a lightning bolt and caused him to plunge into the River Eridanos (= Po). Grief-stricken, Phaeton's sisters Heliades were transformed into poplar trees and their tears into amber. Also grieving for Phaeton was his relative, King Cycnus of Liguria, who was transformed into a swan (Grilli 1991, 17 f; Mastrocinque 1991, 11 ff; Palavestra 1993, 5 f; Šašel Kos 1999, 10; ead. 2005, 116 f; Palavestra/Krstić 2006, 22). The fibula in question incorporates all the essential components of the above-mentioned legend, namely chariot, horses, male figure, swan (the bird in flight has an elongated neck and might represent a swan; it is also true that a bird with outstretched wings is a typical Greco-Italic motif). Moreover, the grave goods of the deceased girl reportedly included amber ornaments and a cult rod. Later depictions of the legend can be found on second- and third-century Roman sarcophagi from north and central Italy (Mastrocinque 1991, Figs. 1–4).

(sl. 99: 5) bi morda lahko pripisali moški opravi glede na to, da nastopata v kombinaciji z bronasto pravokotno pasno spono in pasnimi jezički z obročki, zraven sta spadali še ena certoška fibula vrste V in dolgonožna z mrežastim lokom. V grobni celoti 2/17 s Prelog je bila inventarizirana skupaj s certoško fibulo vrste V in iglo z uvito glavico, vendar je neznano kdaj in kako izginila iz muzejske zbirke. Nekaj takih fibul izvira z izkopavanj vojvodinje Mecklenburške. V grobu V/43 z Laščika je predstavljala edini pridatek, med najdbami groba IV/30a s Prelog pa sta bila menda še dva uhana, ki nista ohranjena. Fibulo s konjsko glavico omenja Goldberg tudi med inventarjem groba VIII/4 s Prelog, kamor so spadale še majhna ovratnica in ogrlica iz modrih in zelenih jagod, konček verižice, dve votli zapestnici ter bronast scepter, medtem ko je objavljen primerek vzhodnoalpske fibule z nazaj gledajočo stilizirano živalsko glavico. Po njegovih navedbah je bila fibula s konjsko glavico najdena tudi v grobu VI/34 s Prelog skupaj s certoško in dvema zapestnicama ter jantarnimi jagodami, kar se prav tako ne sklada z objavljeno grobno celoto.¹⁰⁸⁸ Nedvomno pa sta k moški opravi pripadali fibuli z ovnovo glavico iz groba 2/b s Prelog (sl. 99: 6), ki je vseboval dve sulici, železen raženj in bronasto figuralno okrašeno situlo.¹⁰⁸⁹

Samostrelne fibule s konjsko ali ovnovo živalsko glavico je Gabrovec označil za izrazit jugovzhodnoalpski produkt, ki bi v tipološkem smislu lahko predstavljal derivat certoške fibule.¹⁰⁹⁰ Nošnja teh fibul v dolenski skupnosti ni bila omejena na določen spol ali starost, nosile pa so se sočasno s certoškimi fibulami.¹⁰⁹¹

VZHODNOALPSKE ŽIVALSKÉ FIBULE

Fibule s stilizirano glavico na koncu noge, obrnjeno nazaj proti loku, so bile zelo priljubljene. Med njimi je moč razločiti nekaj variant glede na presek, okrašenosť loka in na izoblikovanost živalske glavice (sl. 99: 9, 19–21).¹⁰⁹² Ženske so jih nosile v kombinaciji z jantarno ogrlico in drobnonarebrenimi ali votlimi zapestnicami, pa tudi z valjastimi uhani z obeski (sl. 100: A7–A10). V podobnih kombinacijah jih zasledimo tudi v otroških opravah. V mešanem sestavu moških in ženskih pridatkov nastopa v grobu X/36 s Prelog, o katerem je Goldberg zapisal, da je v njem ležalo slabo ohranjeno okostje, ki je imelo "latensko ločno fibulo", dve preprosti

¹⁰⁸⁸ Hencken 1978, Fig. 70, 165, 279; Tecco Hvala/Dular/Kocuvan 2004, T. 20E, 117A: 1, 135: 3,4.

¹⁰⁸⁹ Tecco Hvala/Dular/Kocuvan 2004, T. 9: 1,2.

¹⁰⁹⁰ Gabrovec 1966b, 31s, karta 3; za fibule z ovnovo glavico glej še Adam 1996, 94 s.

¹⁰⁹¹ Brezje: Kromer 1959a, T. 6: 5, 21: 2, 43: 4; Dobrnič: Parzinger 1988–1989, T. 25: 3; Novo mesto: Knez 1986, T. 15: 3, 48: 9, 50: 5,6; Križ 1997, T. 67: 3, 70: 1.

¹⁰⁹² Hencken 1978, Fig. 55a, 157b, 182b, 208c, 209a, 232a, 279d, 327i; Tecco Hvala/Dular/Kocuvan 2004, T. 88C: 5, 130B: 3, 137C: 3, 153: 9.

(Vače, Vinica).¹⁰⁸⁵ The fibulae could be dated to the Certosa phase, on the basis of their crossbow spring, which does not appear in the region prior to the said phase,¹⁰⁸⁶ but also on the basis of the shape of the glass beads from Grave 2/c at Magdalenska gora.

More numerously represented are the fibulae with the head of either a horse, a ram or a dog at the end of the foot, whereby the head faces away from the bow (fig. 99: 4–6 and fig. 100: A5, A6). In their basic scheme, they are similar to Certosa fibulae of Type XIII. The two examples with a dog's head are without known or reliable contexts.¹⁰⁸⁷ One was documented within stray finds from Tumulus 13 at Preloge, while the other is published within Grave Group X/50 from Preloge, now part of the Mecklenburg Collection, which is also inconsistent with Goldberg's list. The terminal in the shape of a horse's head is more common. Grave 13/150 at Preloge yielded two such fibulae, tied with a chain, together with an indented bowl on a foot. Only one of the fibulae is preserved. Two examples from Grave 2/11 at Voselca (fig. 99: 5) could be attributed to the male costume on the basis of accompanying finds, namely a bronze rectangular belt clasp and belt attachments with rings, a Type V Certosa fibula and a long-footed fibula with reticular decoration on the bow. Another such fibula was inventoried as part of Grave Group 2/17 from Preloge together with a Type V Certosa fibula and a roll-headed pin, but it disappeared from the museum collection. Several fibulae with a horse's head were also found during the excavations by the Duchess of Mecklenburg. In Grave V/43 at Laščik, it represented the only good, while Grave Group IV/30a from Preloge further included two earrings, now missing. Goldberg mentions such a fibula within the contents of Grave VIII/4 at Preloge, which further consisted of a small torque and a necklace of blue and green beads, part of a chain, two hollow bracelets and a bronze sceptre. The fibula presented in the publication of this grave, however, is of the East Alpine type with a backward-facing stylized animal head. According to Goldberg, another fibula with a horse's head was found in Grave VI/34 at Preloge together with a Certosa fibula, two bracelets and amber beads, which is also inconsistent with the publication of the grave group.¹⁰⁸⁸ Undoubtedly part of the male costume were two fibulae with a ram's head from Grave 2/b at Preloge (fig. 99: 6), which also yielded two spears, an iron spit and a bronze situla with figural decoration.¹⁰⁸⁹

Crossbow fibulae with a horse's or ram's head were marked by Gabrovec as a typically East Alpine product,

¹⁰⁸⁵ Mahr (ed.) 1934, 106, 121, T. 21: 113, 29: 140.

¹⁰⁸⁶ Gabrovec 1966b, 29 f.

¹⁰⁸⁷ Hencken 1978, Fig. 339a; Tecco Hvala/Dular/Kocuvan 2004, T. 126: 6.

¹⁰⁸⁸ Hencken 1978, Figs. 70, 165, 279; Tecco Hvala/Dular/Kocuvan 2004, T. 20E, 117A: 1, 135: 3,4.

¹⁰⁸⁹ Tecco Hvala/Dular/Kocuvan 2004, T. 9: 1,2.

zapestnici s presegačimi konci, jantarne in modre jagode, ob glavi pa dva pasna okova in ob levi nogi sulično ost. Zabeležene so še v nezanesljivih kontekstih (Preloge, gr. VI/34, VII/13) ali pa grobne celote niso znane.

Nekateri primerki odstopajo od tipične oblike vzhodnoalpskih živalskih fibul.¹⁰⁹³ Primerek iz groba 2/21 na Voselci ima ploščat gladek lok, razširjen v smeri proti peresovini in stanjšan proti nogi (sl. 99: 21 in sl. 100: A7), najden pa je bil skupaj z drobnno trortasto fibulo vrste VII po Ogrinovi oz. tip Vinkov Vrh, s pisano ogrlico, drobnonarebrenima zapestnicama in valjastimi uhani. Podobno so oblikovane fibule iz grobov 2/20 z Voselce in 2/40 s Prelog, pri katerih je zaključek noge odlomljen. V grobu 2/40 nastopa v kombinaciji z jantarno ogrlico in dvema drobnonarebrenima zapestnicama, enako kot v voselškem grobu 2/20, le da je k slednjemu spadala še certoška fibula vrste IIB. En primerek pa je zabeležen še med sporadičnimi najdbami iz gomile 13.

Izdelek, ki je pripadal pokojnici v grobu 2/80 s Prelog (sl. 99: 12 in sl. 100: A10), je unikaten. K tej opravi sta menda sodili še dve zapestnici, ki nista ohranjeni.¹⁰⁹⁴ Še najbližjo paralelo bi lahko videli v najdbi iz groba 3/1 z Znančevih njiv v Novem mestu, kjer nastopa skupaj s fibulo s ptičjo ali račjo glavico z razprtimi kljunom (t. i. *Vogelkopf* oz. *Entenkopffibel*),¹⁰⁹⁵ ki se pojavljajo v južnoalpskem svetu ob koncu 6. in v 5. st. pr. n. št.¹⁰⁹⁶

Moda fibul s stilizirano živalsko glavico, obrnjeno proti loku (t. i. *ostalpine Tierkopffibeln*), je zajela širok prostor vzhodnih Alp ter zahodne Panonije. Gabrovec jih je označil kot najmlajše kreacije halštatske kulture in predpostavljala njihovo domovino globoko v alpskem svetu, od koder so se razširile na sever in vzhod v Podonavje. Karta razprostranjenosti teh fibul je bila deležna mnogih dopolnjevanj,¹⁰⁹⁷ kronološko pa so opredeljene v čas od druge četrtine do konca 5. st. pr. n. št.¹⁰⁹⁸ Malce starejša se zdi varianta z razširjenim lokom brez okrasa (sl. 99: 21), ki se na Magdalenski gori pojavlja v kombinaciji s certoško fibulo IIB in najmlajšo lokalno različico trortastih fibul (Voselca, gr. 2/20). Bolj običajna je bila različica z okrašenim lokom,¹⁰⁹⁹ ki je bila v uporabi še

¹⁰⁹³ Tecco Hvala/Dular/Kocuvan 2004, T. 37B: 2, 126: 7, 139A: 3, 139B: 18.

¹⁰⁹⁴ Ibid., T. 62A: 1.

¹⁰⁹⁵ Knez 1986, T. 24: 5.

¹⁰⁹⁶ Frey 1971, 356, T. I: 1, Abb. 2: 1,5,6, 11: 3; id. 1987, op. 2; Pare 1989, 454 s, Abb. 23; Adam 1996, 40 ss, Fig. 3, 4; Nascimbene 2009, 152 ss, Fig. 43, 44, Tab. 18.

¹⁰⁹⁷ Gabrovec 1966b, 31 ss, karta 2; Lunz 1974, 132, T. 82B; Parzinger 1988, T. 146: 1; Teržan 1990a, karta 21; Adam 1996, 87 ss, Fig. 14; Nascimbene 2009, 178 ss, Tab. 24.

¹⁰⁹⁸ Nascimbene 2009, 179 s, z navedbo starejše literature.

¹⁰⁹⁹ *Brezje*, gr. 1/67, 13/51; Kromer 1959a, T. 9: 7, 40: 3, *Dolenjske Toplice*, gr. 5/18, 10/7, 10/8, 13/18; Teržan 1976, T. 32: 7, 58: 1,4, 81: 7; *Novo mesto-Znančeve njive*, gr. 1/16, 3/33, 4/3, 4/28, *Kapiteljska njiva*, gr. 1/29, 5/11; Knez 1986, T. 3: 17, 28: 2, 36: 3, 42: 7; id. 1993, T. 27: 1; Križ 2000, T. 8: 4; *Veliki Gaber-Medvedjek*, gr. 8: Breščak 1982, 157, sl. 24.

which represented a derivative of the Certosa fibula in terms of typology.¹⁰⁹⁰ They were worn by the members of the Dolenjska community regardless of their sex or age and were in use contemporaneously with Certosa fibulae.¹⁰⁹¹

EAST ALPINE ANIMAL-HEADED FIBULAE

Fibulae with a stylized animal head positioned at the end of the foot and facing the bow (*Ostalpine Tierkopffibeln*) were a very popular item of dress. Differences in the cross-section and decoration of the bow as well as the shape of the animal head reveal several variants (fig. 99: 9, 19–21).¹⁰⁹² They were worn by women in combination with an amber necklace, bracelets with thin ribs or hollow bracelets, as well as cylindrical earrings with pendants (fig. 100: A7–A10). They were found within the children's costume in similar combinations. It was also found in a mixed group of both male and female attributes in Grave X/36 at Preloge. For that grave, Goldberg wrote that it contained a poorly preserved skeleton with a "La Tène bow fibula", two simple bracelets with overlapping ends, amber and blue beads, beside the head they found two belt attachments and beside the left foot a spearhead. Further fibulae of this form were found in unreliable (Preloge, Gr. VI/34, VII/13) or unknown contexts.

Some examples differ from the typical form of the East Alpine animal-headed fibula.¹⁰⁹³ The fibula found in Grave 2/21 at Voselca, for example, has a flat plain bow that widens towards the spring and tapers towards the foot (fig. 99: 21 and fig. 100: A7). It was found together with a small three-knobbed fibula of Type VII after Ogrin (= Type Vinkov Vrh), a multicoloured necklace, two bracelets with thin ribs and cylindrical earrings. A similar form can be observed on the fibulae from Graves 2/20 at Voselca and 2/40 at Preloge, where the foot terminal has broken off. In Grave 2/40 it was found in combination with an amber necklace and two bracelets with thin ribs, the same as in Grave 2/20, with the additional Certosa fibula of Type IIB being found in the latter. A further example is recorded among stray finds from Tumulus 13.

The fibula that belonged to the female in Grave 2/80 from Preloge (fig. 99: 12 and fig. 100: A10) is unique. Apart from the fibula, her costume reportedly consisted of two bracelets, now lost.¹⁰⁹⁴ The closest parallel to this

¹⁰⁹⁰ Gabrovec 1966b, 31f, Karte 3; for fibulae with ram's head see also Adam 1996, 94 f.

¹⁰⁹¹ *Brezje*: Kromer 1959a, T. 6: 5, 21: 2, 43: 4; *Dobrnič*: Parzinger 1988–1989, T. 25: 3; *Novo mesto*: Knez 1986, T. 15: 3, 48: 9, 50: 5,6; Križ 1997, T. 67: 3, 70: 1.

¹⁰⁹² Hencken 1978, Figs. 55a, 157b, 182b, 208c, 209a, 232a, 279d, 327i; Tecco Hvala/Dular/Kocuvan 2004, T. 88C: 5, 130B: 3, 137C: 3, 153: 9.

¹⁰⁹³ Tecco Hvala/Dular/Kocuvan 2004, T. 37B: 2, 126: 7, 139A: 3, 139B: 18.

¹⁰⁹⁴ Ibid., T. 62A: 1.

v negovski stopnji, kot priča znameniti dvojni grob 4/3 z Znančevih njiv v Novem mestu. Gre za pokop poglavarja, ki je med drugim imel negovsko čelado ter veliki certoški fibuli vrst X in XI, kakršne so značilne za moško nošo v tem času. Ob njem je bila pokopana ženska, ki ji je pripadalo raznobarvno stekleno okrasje, votel obročast nakit in po vsej verjetnosti vzhodnoalpski živalski fibuli. V Hallstattu in v Szentlörincu so take fibule prav tako nosile ženske, medtem ko naj bi v Dürrnbergu in v Paularu-Misincinis nastopale tudi v moških opravih.¹¹⁰⁰

SAMOSTRELNE FIBULE Z OKRASNO NOGO

Posamično se v magdalenskogorskih grobovih pojavljajo še drugi tipi samostrelnih fibul, ki so pomenljivi predvsem za ugotavljanje povezav z drugimi kulturnimi sredinami. Mednje spada fibula s kvadratno ного (sl. 99: 7 in sl. 100: B1), ki je bila najdena v grobu 13/153 s Prelog skupaj s certoško fibulo vrste Ib in pravokotno pasno spono s pasnimi jezički in obročki.¹¹⁰¹ Take fibule se pojavljajo v zahodnohalštatskem krogu, medtem ko so v jugovzhodnih Alpah redke, v dolenski halštatski skupnosti pa je magdalenskogorski primerek edinstven. Ena taka fibula je znana še z Bitenj na Gorenjskem in dve z Mosta na Soči, kjer so datirane v stopnjo Sv. Lucija Iib.¹¹⁰²

V grobu 2/55 s Prelog na Magdalenski gori je bila najdena fibula s prečno našlebljenim lokom in s pridvignjenim jabolčastim zaključkom noge, ki ima v sredini vdolbinico,¹¹⁰³ morda je bila vanjo vdeta inkrustacija oz. koralna (sl. 99: 8 in sl. 100: B2). Z območja jugovzhodnih Alp so podobni primerki znani z Vač in Mosta na Soči, sledimo jim lahko v Padsko nižino (Este, Bagnolo S. Vito), v porečje Ticina (Arbedo) ter na jursko območje vse do zgornjega toka Rhône. Datirane so v konec 6. in prvo polovico 5. st. pr. n. št.¹¹⁰⁴

V grobu 13/116 s Prelog na Magdalenski gori nastopa dolgonožna fibula s samostrelno peresovino (sl. 99: 11 in sl. 100: B3),¹¹⁰⁵ ki bi jo lahko uvrstili med fibule tipa Castellin di Fisterre, le da imajo te običajno enostransko peresovino. Poimenovane so po nekropoli v bližini Caverzana na območju Belluna in predstavljajo izdelke delavnic v Poadižju, kjer so zastopane tudi v depojih

¹¹⁰⁰ Nascimbene 2009, 186, Tab. 24.

¹¹⁰¹ Teržan 1976, sl. 19; Tecco Hvala/Dular/Kocuvan 2004, 117B: 3.

¹¹⁰² Frey 1971, 360 ss, Abb. 4: 3; Gabrovec 1974b, 302 ss, sl. 6; Teržan/Trampuž 1973, 432 s. Po Mansfeldu se uvršča v tip F2/G1, ki je datiran v poznohalštatsko obdobje (Mansfeld 1973, 37 ss, T. 11: 88-90, Fundliste 259); Adam 1996, 36 ss, Fig. 2.

¹¹⁰³ Tecco Hvala/Dular/Kocuvan 2004, T. 49A: 3.

¹¹⁰⁴ Frey 1971, Abb. 4: 2; De Marinis 1987, 91 s, Fig. 4: f, 5: 10; Pare 1989, 454 ss, Abb. 21; Adam 1996, 46 ss, Fig. 5; De Marinis 1997, 155 ss.

¹¹⁰⁵ Tecco Hvala/Dular/Kocuvan 2004, T. 104B: 1.

fibula can be seen in a find from Grave 3/1 at Znančeve njive in Novo mesto, which was found together with a fibula with either a bird's or a duck's head with an open beak (*Vogelkopf-* or *Entenkopffibel*).¹⁰⁹⁵ The latter were present in the south Alpine area at the end of the sixth and in the fifth century BC.¹⁰⁹⁶

The fibulae with a stylized animal head facing the bow (*Ostalpine Tierkopffibeln*) were in vogue across a wide area of the eastern Alps and western Pannonia. Gabrovec saw them as the latest creation of the Hallstatt culture and supposed their origin deep in the Alps, whence they spread northwards and eastwards into Pannonia.¹⁰⁹⁷ They date from the second quarter to the end of the fifth century BC.¹⁰⁹⁸ The variant with a tapering undecorated bow appears to have been somewhat earlier (*fig. 99: 21*), found at Magdalenska gora in combination with a Type Iib Certosa fibula and the latest local variant of the three-knobbed fibulae (Voselca, Gr. 2/20). A more common variant was that with a decorated bow,¹⁰⁹⁹ which remained in use into the Negova phase, as evidenced by the famous double Grave 4/3 from Znančeve njive in Novo mesto. The latter was a grave of a chieftain who was buried, among other goods, with a Negova helmet and two large Certosa fibulae of Types X and XI, such as characterize the male costume of the period. Buried alongside the chieftain was a woman with multicoloured glass adornments, hollow ring jewelry and very likely also two East Alpine animal-headed fibulae. These fibulae were worn by women at Hallstatt and Szentlörinc, while at Dürrnberg and Paularo-Misincinis they also appeared in male graves.¹¹⁰⁰

CROSSBOW FIBULAE WITH A DECORATED FOOT

Other types of crossbow fibulae appear in the graves of Magdalenska gora only sporadically. These are of importance mostly for observing the connections of the site with other cultural milieus. One such fibula (*Fußzierfibel*), with a square-stamp foot terminal, was found in Grave 13/153 at Preloge (*fig. 99: 7* and *fig. 100: B1*) together with a Certosa fibula of Type Ib and a rec-

¹⁰⁹⁵ Knez 1986, T. 24: 5.

¹⁰⁹⁶ Frey 1971, 356, T. I: 1, Abb. 2: 1,5,6, 11: 3; *id.* 1987, n. 2; Pare 1989, 454 f, Abb. 23; Adam 1996, 40 ff, Figs. 3, 4; Nascimbene 2009, 152 ff, Figs. 43, 44, Tab. 18.

¹⁰⁹⁷ Gabrovec 1966b, 31 ff, Karte 2; Lunz 1974, 132, T. 82B; Parzinger 1988, T. 146: 1; Teržan 1990a, map 21; Adam 1996, 87 ff, Fig. 14; Nascimbene 2009, 178 ff, Tab. 24.

¹⁰⁹⁸ Nascimbene 2009, 179 f, with references.

¹⁰⁹⁹ *Brezje, Gr. 1/67, 13/51*: Kromer 1959a, T. 9: 7, 40: 3, *Dolenske Toplice, Gr. 5/18, 10/7, 10/8, 13/18*: Teržan 1976, T. 32: 7, 58: 1,4, 81: 7; *Novo mesto-Znančeve njive, Gr. 1/16, 3/33, 4/3, 4/28, Kapiteljska njiva, Gr. 1/29, 5/11*: Knez 1986, T. 3: 17, 28: 2, 36: 3, 42: 7; *id.* 1993, T. 27: 1; Križ 2000, T. 8: 4; *Veliki Gaber-Medvedjek, Gr. 8*: Breščak 1982, 157, fig. 24.

¹¹⁰⁰ Nascimbene 2009, 186, Tab. 24.

(Campo Paraiso v okolici Verone, Mechel, Obervintl pri Bolzanu).¹¹⁰⁶ Posamični primerki so zašli na zahod v kulturni krog Golasecca, na jug v Padsko nižino in Picenum, na sever v Dürrenberg, na vzhod pa v dolini Piave in Soče. Najvzhodnejši najdišči predstavljata Vače in Magdalenska gora. Datirane so na konec 6. in v 5. st. pr. n. št. Na Magdalenski gori sta zabeležena še dva podobna primerka,¹¹⁰⁷ eden je objavljen v sklopu groba VII/5 s Prelog, v katerem naj bi bili po Goldbergovih poročilih najdeni dve ločni fibuli, v objavi pa so predstavljene štiri. Drug primerek izvira iz groba V/37 z Laščika, pri katerem je peresovina odlomljena. Goldberg je zapisal, da so bili na to fibulo nataknjeni majhni obročki, razen tega naj bi v tem grobu našli jantarno ogrlico, modre in zelene steklene jagode, dve votli zapestnici in križno oblikovan gumb. Samostrelno peresovino imajo še nekateri drugi tipi dolgonožnih fibul (sl. 99: 10),¹¹⁰⁸ večkrat uporabljena pa je bila pri raznih certoških fibulah (sl. 94: 7, 11, 12, 15, 18).

PAVKASTE FIBULE

Med magdalenskogorskimi najdbami se pojavljajo tudi zahodnohalštatski tipi zaponk, vendar nobena ni izpričana v zanesljivem kontekstu. Uvrščajo se med dvojno pavkaste fibule (t. i. *Doppelpaukenfibeln*), med njimi pa so opazne razlike v oblikovanosti loka in zaključka noge. Prva različica ima polkrožen presek pavk z vdolbinico v sredi (sl. 99: 13), zaključek noge je sicer pri obeh magdalenskogorskih primerkih odlomljen.¹¹⁰⁹ Sorodni sta primerkom z območja južnih Alp in iz Padske nižine, ki so datirani v prvo polovico 5. st. pr. n. št.¹¹¹⁰ Druga različica, ki ima bolj sploščeni pavki z iztolčenim koncentričnim krožcem in bunčico na sredi (sl. 99: 17, 18),¹¹¹¹ se uvršča med t. i. *Alpine Blechpaukenfibeln*, z najboljšimi paralelami v južnoalpskih dolinah.¹¹¹² Tretja različica ima ulit diskast lok, okrašen z vrezanim koncentričnimi krožci in vdolbinico v sredi, ter križno oblikovan zaključek noge, nanj sta nataknjeni dve pavkasto oblikovani ploščici z enakim okrasom, ki

¹¹⁰⁶ Eles Masi 1986, 198 s; Nascimbene 2009, 110 ss, Fig. 23, 24, Tab. 9. V grobu *Este-Costa Martini 41* nastopa fragment noge, ki bi lahko pripadal taki fibuli; najden je bil skupaj z železno predrto pasno spono, umbom in certoško fibulo X vrste, ki so značilne za stopnjo Este III pozno (Teržan 1976, 364, sl. 33: 6).

¹¹⁰⁷ Hencken 1978, Fig. 158g, 223f.

¹¹⁰⁸ Ibid., Fig. 170d, 223a,d.

¹¹⁰⁹ Frey 1971, 377, Abb. 4: 1; Hencken 1978, Fig. 229g; Tecco Hvala/Dular/Kocuvan 2004, T. 153: 6.

¹¹¹⁰ Frey 1971, T. I: 3-6, Abb. 2: 10-13; Adam 1996, 56 ss, Fig. 8.

¹¹¹¹ Hencken 1978, Fig. 82j; Tecco Hvala/Dular/Kocuvan 2004, T. 153: 5.

¹¹¹² Frey 1971, Abb. 3: 4; Lunz 1974, T. 74: 8, 75: 5; Adam 1996, 66 ss, Fig. 10, T. I: 18-19.

tangular belt clasp with attachments and rings.¹¹⁰¹ Such fibulae are common in the West Hallstatt circle, while they are rare in the south-eastern Alps, the example from Magdalenska gora being the only of its kind within the Dolenjska Hallstatt community. One other fibula is known from Bitnje in Gorenjska and two from Most na Soči, where they date to the Sv. Lucija IIB phase.¹¹⁰²

Grave 2/55 at Preloge yielded a fibula with transverse grooves on the bow and a raised apple-shaped foot terminal with a small hollow in the centre,¹¹⁰³ whereby the latter may once have contained incrustation or a coral inlay (fig. 99: 8 and fig. 100: B2). Similar examples are known from the south-eastern Alpine area at Vače and Most na Soči, while they can be traced into the Po Plain (Este, Bagnolo S. Vito), to the Ticino basin (Arbedo) and the Jura Mountains all to the upper reaches of the Rhône. They date to the end of the sixth and first half of the fifth century BC.¹¹⁰⁴

Grave 13/116 at Preloge yielded a long-footed fibula with a crossbow spring (fig. 99: 11 and fig. 100: B3),¹¹⁰⁵ which could be identified as Type Castellin di Fisterre, the only difference being in the latter type usually having a one-sided spring. They were named after the cemetery in the vicinity of Caverzano in the Belluno area and represent products of the workshops in the Adige basin, where they were also found in hoards (Campo Paraiso near Verona, Mechel, Obervintl near Bolzano).¹¹⁰⁶ Individual examples travelled westwards into the Golasecca cultural circle, southwards to the Po Plain and Picenum, northwards to Dürrenberg and eastwards into the valleys of the Piave and Soča. The easternmost sites of their distribution are Vače and Magdalenska gora. The fibulae date to the end of the sixth and the fifth century BC. Two further, similar examples were documented at Magdalenska gora.¹¹⁰⁷ One was found in Grave VII/5 from Preloge, for which Goldberg noted two bow fibulae, while the publication lists four. The other example, the coiled spring of which has broken off, was unearthed in

¹¹⁰¹ Teržan 1976, Abb. 19; Tecco Hvala/Dular/Kocuvan 2004, 117B: 3.

¹¹⁰² Frey 1971, 360 ff, Abb. 4: 3; Gabrovec 1974b, 302 ff, Abb. 6; Teržan/Trampuž 1973, 432 f. According to Mansfeld, the fibula is classified in Type F2/G1 dated to the Late Hallstatt period (Mansfeld 1973, 37 ff, T. 11: 88-90, Fundliste 259); Adam 1996, 36 ff, Fig. 2.

¹¹⁰³ Tecco Hvala/Dular/Kocuvan 2004, T. 49A: 3.

¹¹⁰⁴ Frey 1971, Abb. 4: 2; De Marinis 1987, 91 f, Figs. 4: f, 5: 10; Pare 1989, 454 ff, Abb. 21; Adam 1996, 46 ff, Fig. 5; De Marinis 1997, 155 ff.

¹¹⁰⁵ Tecco Hvala/Dular/Kocuvan 2004, T. 104B: 1.

¹¹⁰⁶ Eles Masi 1986, 198 f; Nascimbene 2009, 110 ff, Figs. 23, 24, Tab. 9. A fragment of the foot supposedly belonging to this fibula type was documented in Grave *Este-Costa Martini 41*. It was found together with an iron openwork belt hook, an umbo and a Type X Certosa fibula, characteristic of Este III Late (Teržan 1976, 364, Abb. 33: 6).

¹¹⁰⁷ Hencken 1978, Figs. 158g, 223f.

sta bili posebej izdelani (sl. 99: 16).¹¹¹³ V vdolbinice so bile morda vdete korale ali inkrustacija, ki je izpadla. Predstavljajo južnoalpski tip, ki sodi med najmlajše različice geografsko zelo razširjenih dvojnopavkastih fibul s samostrelno konstrukcijo.¹¹¹⁴ Četrta varianta pa ima okrogli ploščici, izdelani iz pločevine, ki sta pritrjeni na trakast lok in nazaj zavito nogo; ploščata diska sta v sredini preluknjana, v luknjico je vdeta zanka, na katero so bili nataknjeni trikotni obeski (sl. 99: 14).¹¹¹⁵ Največ takih fibul je znanih iz Mechla (10 kosov) in Magdalenske gore (6 kosov), en kos pa je zastopan tudi v Hallstattu.¹¹¹⁶ Nekakšni fibuli z diski omenja Goldberg v grobu IV/32 s Prelog na Magdalenski gori. Ta grob je imenovan konjski grob II, lociran naj bi bil bolj v bližino kot v samo gomilo, vseboval pa naj bi še čelado, pravokotno pasno spono, pasni obroček, sulično ost, nož, okrašen koščen okov, situlo in še en majhen lonec.¹¹¹⁷

Iz tega pregleda figuralnih fibul in zahodnohalštatskih tipov lahko zaključimo, da je dolenska skupnost sprejemala novo modo in idejne vzore predvsem prek delavnic, ki so delovale v prvi polovici 5. st. pr. n. št. v severnoitalskem prostoru in morebiti na Mostu na Soči. Tipičen primer sinkretizma jugovzhodnoalpske halštatske kulture predstavljajo fibule z nogo v obliki pasje, konjske, ovnove glavice. V severnoitalski interpretaciji so v ta prostor prodrle tudi pavkaste fibule. V najmlajšem halštatskem obdobju pa je bila daleč najbolj priljubljena vzhodnoalpska živalska fibula, ki je prevladovala v ženski noši celotnega vzhodnoalpskega prostora vse tja do zgornejga in srednjega Podonavja.

4.7.10 ZAKLJUČEK

Zaponke za spenjanje oblačil so bile podvržene modnim trendom, ki so se širili prek regionalnih meja, zato so na eni strani občutljiv kronološki kazalec, na drugi strani pa nekakšna Ariadnina nit, ki nas vodi po sledih čezmejnih stikov, kar je že zelo staro spoznanje. Primat kreatorstva posameznih tipov ni vselej jasen.

Na Magdalenski gori so najstarejše enozankaste fibule s povezavami na zahodu. V stopnji Podzemelj je simbol dolenske halštatske identitete predstavljala t. i. vaška fibula z železnim jedrom in bronastim vozlastim

¹¹¹³ Hencken 1978, Fig. 229e; Tecco Hvala/Dular/Kocuvan 2004, T. 153: 3,4.

¹¹¹⁴ Frey 1971, Abb. 2: 4, 3: 3, 4: 5; Heimann 2007, Abb 7; Nascimbene 2009, 147 ss, Fig. 41, 42, tab. 17. Za primerjavo glej še fibulo iz *Ikevárja-Pinkóci*: Nagy 2011, 166 ss, sl. 104.

¹¹¹⁵ Hencken 1978, Fig. 339b; Tecco Hvala/Dular/Kocuvan 2004, T. 39A: 2,3, 66A: 1, 153: 7,8.

¹¹¹⁶ Frey 1971, Abb. 4: 6; Adam 1996, 68 ss, Fig. 11: A, 12.

¹¹¹⁷ Hencken 1978, 23.

Grave V/37 at Laščik. Goldberg wrote that small rings were hanging from the latter fibula, while the grave further revealed an amber necklace, blue and green glass beads, two hollow bracelets and a cruciform button. The crossbow springs appears in some other types of long-footed fibulae (fig. 99: 10),¹¹⁰⁸ but it was also used in various types of Certosa fibulae (fig. 94: 7, 11, 12, 15, 18).

KETTLEDRUM FIBULAE

The finds from Magdalenska gora include West Hallstatt types of fibulae, though none are evidenced within a reliable context. In type, they belong to the double-kettledrum fibulae (*Doppelpaukenfibeln*), but show differences in the shape of the bow and foot terminal. The first variant has a semi-circular cross-section of the kettledrums with a hollow in the centre (fig. 99: 13); the foot terminal is broken off in both examples of the variant from Magdalenska gora.¹¹⁰⁹ They are similar to the examples from the southern Alps and the Po Plain, dated to the first half of the fifth century BC.¹¹¹⁰ The second variant, with flattened kettledrums with an embossed concentric circle and dot in its centre, (fig. 99: 17, 18),¹¹¹¹ ranks among the *Alpine Blechpaukenfibeln*, with closest parallels in the southern Alpine valleys.¹¹¹² The third variant has a cast disc-shaped bow, decorated with incised concentric circles and a hollow in the centre, as well as a cruciform foot terminal. Attached to the foot are two kettledrum-shaped and separately made plates with the same decoration (fig. 99: 16).¹¹¹³ The hollows may once have contained coral inlays or incrustation. This South Alpine variant is among the latest variants of the very widespread double-kettledrum fibulae with a crossbow construction.¹¹¹⁴ The fourth variant has two round plates made of sheet metal and attached to the band bow and reverted foot; the flat discs are perforated in the centre and a loop with triangular pendants is inserted into the perforation (fig. 99: 14).¹¹¹⁵ Most fibulae of this variant are known from Mechel (10 examples) and Magdalenska gora (6 examples), one was even found at

¹¹⁰⁸ *Ibid.*, Figs. 170d, 223a,d.

¹¹⁰⁹ Frey 1971, 377, Abb. 4: 1; Hencken 1978, Fig. 229g; Tecco Hvala/Dular/Kocuvan 2004, T. 153: 6.

¹¹¹⁰ Frey 1971, T. I: 3-6, Abb. 2: 10-13; Adam 1996, 56 ff, Fig. 8.

¹¹¹¹ Hencken 1978, Fig. 82j; Tecco Hvala/Dular/Kocuvan 2004, T. 153: 5.

¹¹¹² Frey 1971, Abb. 3: 4; Lunz 1974, T. 74: 8, 75: 5; Adam 1996, 66 ff, Fig. 10, T. I: 18-19.

¹¹¹³ Hencken 1978, Fig. 229e; Tecco Hvala/Dular/Kocuvan 2004, T. 153: 3,4.

¹¹¹⁴ Frey 1971, Abb. 2: 4, 3: 3, 4: 5; Heimann 2007, Abb 7; Nascimbene 2009, 147 ff, Figs. 41, 42, Tab. 17. Cf. a fibula from *Ikevár-Pinkóci*: Nagy 2011, 166 ff, Abb. 104.

¹¹¹⁵ Hencken 1978, Fig. 339b; Tecco Hvala/Dular/Kocuvan 2004, T. 39A: 2,3, 66A: 1, 153: 7,8.

plaščem (= tip 5a po Gabrovcu), ki je na Magdalenski gori zastopana v žganih grobovih. V žganih grobovih zasledimo tudi bronaste različice (= tipa 6a in 6d po Gabrovcu), ki so bile razširjene v štajerski, koroški in svetolucijski skupnosti.

V stopnji Stična so v dolenskih delavnicah izdelovali dvozankaste fibule z votlim lokom, ki se od sorodnih svetolucijskih razlikujejo po velikosti in okrasu "jelkovih vejic" na loku. V dolenski skupnosti so posnemali tudi t. i. glasinaški tip dvozankaste fibule (= tip 8 po Gabrovcu). V tistem času je močnejše zavel veter z Apeninskega polotoka, ki je v jugovzhodne Alpe prinesel čolničaste, rtaste in zgodnje kačaste fibule. Čolničaste fibule se na Magdalenski gori večinoma pojavljajo v skeletnih grobovih z izjemo groba 1892/13, ki je vseboval različico 3. skupine po Jerinovi, kakršna je značilna za severnoitalski in svetolucijski prostor. Med lokalne produkte lahko prištevamo čolničaste fibule z železno iglo in šmarješki tip (= 2b po Jerinovi), ki je bil razširjen v vzhodnoalpskem in zahodnem panonskem svetu, na italiskem polotoku pa jih niso uporabljali. V izjemnih ženskih opravah stopnje Stična zasledimo še fibule s stekleno, jantarno ali koščeno oblogo, ki so odsev orientalizirajočega stila z italskega polotoka, čeprav so primerki t. i. ježevk posebnost Dolenjske, kjer sporadično nastopajo tudi v mlajših stopnjah.

Trortaste fibule kažejo na čezjadransko pot med Picenumom in jugovzhodnimi Alpami. Poleg uniformne oblike, ki jo izraža t. i. tip Grottazzolina, so bile v uporabi tudi bolj lokalne različice, najmlajša med njimi je dolenska drobna trortasta fibula (= vrsta VII po Ogrinovi ali tip Vinkov Vrh po Lo Schiavovi) iz časa certoške stopnje, ki se ni razširila onstran meja dolenske in svetolucijske skupnosti. Posamični kosi so znani le še iz Donje Doline, Sremske Mitrovice in Jezerin, ki tako pričajo o povezavah s skupnostmi v Posavju in z Japodi. Na drugi strani pa o stikih s prebivalci notranjealpskih dolin v 6. stol. govori alpska dvortasta fibula.

V 6. st. pr. n. št. se je udomačila noša kačastih fibul. Najzgodnejše oblike tovrstnih zaponk (kačasta z dvema zankama na loku, z valovitim lokom, s pestiči) zasledimo že v stopnji Stična in so zagotovo italskega porekla. Takrat so jih pričeli nositi tudi moški, ki so poprej za spenjanje oblačil uporabljali igle. V drugi fazi so se razmahnile kačaste fibule s sedlastim lokom in s krilci, ki so značilne za prostor med Adižo in Savo. Približno v istem času so stopile v svet mode tudi trakaste fibule, ki so v glavnem omejene na prostor med Sočo in Savo. Kačaste fibule so se v izvedbi s trakasto zanko in masivno profilirano nogo obdržale še v certoški stopnji.

V certoški stopnji se je razmahnila moda certoških fibul, ki je zajela dežele severnojadranskega loka vse do zahodne Panonije in centralnega Balkana. V manjši meri so na Dolenjskem zastopane še razne drobne ločne, fibulalne, dolgonožne in samostrelne fibule z okrasno

Hallstatt.¹¹¹⁶ A sort of fibula with discs is also mentioned by Goldberg for Grave IV/32 at Preloge. Also named Horse Grave II, it was located more near than within the tumulus and reportedly contained, apart from the fibula, a helmet, a rectangular belt clasp, a belt ring, a spearhead, a knife, a decorated bone fitting, a situla and a small jar.¹¹¹⁷

The above overview of figural and West Hallstatt fibulae allows for a conclusion that the Dolenjska community adopted new fashions and ideas primarily through the workshops active in the first half of the fifth century BC in northern Italy and possibly at Most na Soči. A typical example of the syncretism of the South-Eastern Alpine Hallstatt culture can be seen in the fibulae with the foot in the shape of either a dog's, horse's or ram's head. Kettledrum fibulae also arrived to the area, albeit in a north Italian interpretation. By far the most popular type in the latest Hallstatt phase was the East Alpine animal-headed fibula, which dominated the female costume across the eastern Alps and up to the upper and middle reaches of the Danube.

4.7.10 CONCLUSION

Brooches for fastening clothing were items of fashion that spread beyond the boundaries of a single community or region. For that reason they serve, on the one hand, as a very sensitive chronological indicator, and on the other, as a sort of Ariadne's thread that allows us to retrace the paths of cross-border contacts. Having said that, we are not always able to ascertain the primacy in the creation of individual types.

One of the earliest forms of brooches or fibulae at Magdalenska gora is single-looped fibulae, which reflect contacts with the west. In the Podzemelj phase, the symbol of the Dolenjska identity was the Vače fibula, with an iron core and a bronze knobbed coat (= Type 5a after Gabrovec), which appears at Magdalenska gora in cremation graves. The latter came in bronze variants as well (= Types 6a and 6d after Gabrovec), which were in use in the Styria / Štajerska, Carinthia / Koroška and Sveta Lucija communities.

In the Stična phase, the Dolenjska workshops were making two-looped fibulae with a hollow bow. These local products differ from the related Sveta Lucija fibulae in the size and the pine-sprig decoration on the bow. The Dolenjska community also produced imitations of the Glasinac type of two-looped fibulae (Group 8 after Gabrovec). On the other hand, the phase witnessed growing contacts with the Apennine Peninsula, which brought to

¹¹¹⁶ Frey 1971, Abb. 4: 6; Adam 1996, 68 ff, Fig. 11: A, 12.

¹¹¹⁷ Hencken 1978, 23.

nogo (t. i. *Fußzierfibeln*) ter dvojnopavkaste fibule (t. i. *Doppelpaukenfibeln*). Idejne pobude zanje je moč iskati v severnoitalskih in zahodnohalštatskih prototipih, ki so jih posnemali v jugovzhodnoalpskih delavnicah. Ob koncu certoške in na začetku negovske stopnje so se v ženski noši uveljavile vzhodnoalpske živalske fibule (t. i. *Ostalpine Tierkopffibeln*), ki so preplavile vzhodne Alpe vse tja do zgornjega in srednjega Podonavja. Moški so v tem času nosili velike certoške fibule (vrsti X in XI po Teržanovi) ter železne izvedbe. Slednje odražajo zgodnjelatenske vplive, pri čemer so posredovalno vlogo odigrale severnoitalske skupnosti. V prostoru med zgornjim tokom Soče in Save ter na jugu do Sane so v poslednji fazi halštatskega obdobja nosili svojsko oblikovane certoške fibule (vrste VIIe/f in XII), ki so se ohranile še v noši latenskega časa.

Magdalenska gora je v starejšem halštatskem obdobju po količini dvozankastih in čolničastih fibul zaostajala za drugimi dolensjkimi središči, predvsem za Velikim Vinjim vrhom (Šmarjeto), Stično in Vačami. Po drugi strani pa so na Magdalenski gori zastopani nekateri tipi, ki so v tej kulturni sredini redki, kot npr. dvozankasta fibula tipa 6d po Gabrovcu ali čolničaste 3. skupine po Jerinovi, nekatere inačice trortastih fibul ter kačaste z dvema zankama ali z valovitim lokom, ki so severnoitalske ali svetolucijske provenience. Razen tega v tem času izstopa po količini fibul s stekleno oblogo.

S kačastimi fibulami se postavlja ob bok Stični in Vačam. Daleč pred drugimi se uvršča po trakastih fibulah, s certoškimi fibulami pa je osvojila absoluten primat med dolensjkimi najdišči – z dvotretjinskim deležem primerkov vrste II, polovičnim deležem vrst V in XIII ter skoraj tričetrtinskim deležem vrste X. Na tem najdišču so zabeleženi tudi izjemni primerki figuralnih fibul (v obliki trige ali konjička) ali z okrasno nogo ter pavkaste fibule in železni primerki.

Vse to nakazuje, da je Magdalenska gora nemara že od samega začetka zavzemala posebno mesto v komunikaciji z zahodnimi skupnostmi, kar je razumljivo glede na njeno geografsko lego. V mlajšem halštatskem obdobju pa je morda predstavljala tudi eno od izdelovalnih središč nekaterih vrst certoških fibul (zlasti vrst X in XIII) in lokalnih pavkastih fibul. Ob tem so znane še zgodnjelatenske oblike fibul¹¹¹⁸ ter poznolatenski primerki iz grobov, ki so bili naknadno vkopani v gomile in jih tukaj ne obravnavam.¹¹¹⁹

the south-eastern Alps new forms, namely boat, two- or three-knobbed and early serpentine fibulae. Boat fibulae appear at Magdalenska gora predominantly in inhumation graves. The exception is Grave 1892/13 that revealed a variant of a Group 3 fibula after Jerin, such as characterized the north Italian and Sveta Lucija regions, but rarely formed part of the Dolensjka costume. The boat fibulae that were locally produced were those with an iron pin and Type Šmarjeta (= 2b after Jerin), whereby the latter were widespread in the eastern Alps and western Pannonia and not in use on the Apennine Peninsula. Furthermore, the outstanding female costume included fibulae with either a glass, amber or bone overlay, which certainly reflect the Orientalising style from Italy. Having said that, the fibulae with a spiky glass overlay are a characteristic of Dolensjka, where they individually appear even in later phases.

The three-knobbed fibulae point to a transadriatic route connecting Picenum and the south-eastern Alps. Apart from the uniform Type Grottazzolina, more locally oriented variants were also in use, the latest among them being the small Dolensjka three-knobbed fibula (= Type VII after Ogrin or Type Vinkov Vrh after Lo Schiavo) from the Certosa phase, which was not worn outside the Dolensjka and Sveta Lucija communities. The individual finds of the fibula type at Donja Dolina, Sremska Mitrovica and Jezerine reveal the ties of the Dolensjka community with those in the Sava basin and with the Iapodes. The contacts with the inner Alpine valleys in the sixth century, on the other hand, are revealed by the Alpine two-knobbed fibulae, which are poorly represented in Dolensjka.

In the sixth century BC, the serpentine fibula became a well-accepted item of costume in Dolensjka. The earliest forms (with two loops on the bow, with a wavy bow, with antennae), which are certainly of Italic origin, may be traced back to the Stična phase. The serpentine fibulae were the first to be worn also by men, who had previously used pins to fasten their clothing. The second wave of serpentine fibulae introduced those with a saddle-shaped bow and with wings, which are characteristic of the area between the Adige and the Sava. At roughly the same time, band bow fibulae also began to be worn, mainly in the area between the Soča and the Sava. The serpentine fibulae with a band bow curved into a loop and solid moulded foot were retained into the Certosa phase.

The fashion of the Certosa phase was certainly for the Certosa fibulae, which spread from the northern Adriatic to western Pannonia and the central Balkans. Apart from those, the Dolensjka community also wore various small bow, figural, long-footed and crossbow fibulae with a decorative foot, as well as double-kettledrum fibulae, though in smaller numbers. The idea behind these forms is to be sought in the north Italian and west Hallstatt prototypes, which were imitated in the workshops of the south-eastern Alps. At the end of the Certosa and the beginning of the Negova phase, the female costume was dominated by the East Alpine

¹¹¹⁸ Hencken 1978, Fig. 114e, 274d, 355a; Tecco Hvala/Dular/Kocuvan 2004, T. 138: 20.

¹¹¹⁹ Hencken 1978, Fig. 9a, 72a, 106b, 116b, 248d, 251b, 345a, 362d; Tecco Hvala/Dular/Kocuvan 2004, T. 2A, 10B, 19B: 8-10, 20A: 1, 31B: 1,2, 155: 14.

4.8 OVRATNICE IN OGRVICE

4.8.1 OVRATNICE

Tipološke značilnosti. Ovratnice iz magdalensko-gorskih grobov so razen enega svinčenega primerka vse bronaste. Razlikujejo se po velikosti in načinu izdelave: ene so masivne z razkovanimi in uvitimi zaključki (sl. 101), druge so izdelane iz tanke bronaste pločevine, pri katerih so masivni kroglasti zaključki vdeti v cevast obroč ter pritrjeni z zakovico (sl. 102). Nadaljnja tipološka delitev je možna glede na okrasne prvine. Med masivni ovratnicami nastopajo gladke žičnate brez okrasa, tj. različica **A1** (sl. 101: 1); nekatere so ornamentirane s snopi vrezov, ki jih označujem kot različico **A2** (sl. 101: 2, 3), ali pa so tordirane (sl. 101: 4). Ena je narebrena, tj. različica **B** (sl. 101: 5), veliko pa je vozlastih, ki jih delim na različico **D1** brez dodatnega okrasa (sl. 101: 7) ter na različico **D2**, ki je okrašena s snopi prečnih vrezov ali ozkih žlebičev med vozli (sl. 101: 8–10). Unikatni izdelek predstavlja ovratnica z zaključkoma v obliki kačjih glav in z okrasom vtisnjenih pik, tj. različica **C** (sl. 101: 6). Edinstven je tudi torkvez iz svinca (**Pb**), ki je okrašen s prečnimi vrezi in izstopajočimi buncicami (sl. 102: 6).

Votle ovratnice so običajno gladke brez okrasa (različica **V3**), bolj redko so ornamentirane z vrezi (različici **V2** in **V4**), zaključki pa so kroglasti in polno uliti (sl. 102: 2, 4, 5), medtem ko ima narebreni primerek različice **V1** zaključka zankasto uvita (sl. 102: 1). Med najdbami z Voselce je zabeležen par zaključkov, ki sta ulita v obliki živalske glave (sl. 102: 3).

Lega in kontekst. V zbirki ljubljanskega muzeja sta inventarizirani dve tordirani ovratnici – ena ima konca okroglega preseka (sl. 101: 4), druga pa pravokotnega.¹¹²⁰ Pri slednji je kot najdišče navedena gomila v Hrastju, ki jo je kopal Schulz v letih 1882/83; enako oznako pa ima še ena gladka ovratnica. Zanju domnevam, da sta pripadali žarnemu grobu 6/1 z Voselce (sl. 24: d in sl. 103), kajti v njem naj bi po poročanju Dežmana našli dve ovratnici v situli z rdeče in črno barvanimi pasovi, pokriti z bronastim krožnikom, razen tega še jantarni ploščici in jagode ter dve zapestnici.¹¹²¹

Gladke žičnate ovratnice brez okrasa (različica **A1**) zasledimo tako v žganih kot skeletnih grobovih (sl. 103), razen tega je zabeleženih še nekaj primerkov brez grob-

animal-headed fibulae, which flooded the eastern Alps all to the northern and central Danube basin. Men, at this time, began wearing large Certosa fibulae (Types X and XI after Teržan) and iron versions. The latter reflect Early La Tène influences, probably transmitted by the north Italian communities. The last phase of the Hallstatt period, in the area between the upper reaches of the Soča and Sava, and to the south to the Sana River, retained the fashion for Certosa fibulae, but in local variants (VIIe/f and XII), which lasted into the La Tène period.

Magdalenska gora, in the Early Hallstatt period, lagged behind other centres of Dolenjska in the number of two-looped and boat fibulae, particularly behind Veliki Vinji vrh (Šmarjeta), Stična and Vače. On the other hand, types otherwise rare within the Dolenjska community, were better represented at Magdalenska gora. The types in question are two-looped fibulae of Type 6d after Gabrovec and boat fibulae of Type 3 after Jerin, several versions of three-knobbed fibulae, as well as serpentine with two loops or with a wavy bow, which are either north Italian or Sveta Lucija in provenance. Magdalenska gora also stands out in the number of fibulae with a glass overlay.

In the number of serpentine fibula, it stands side by side with Stična and Vače. It is far ahead in the number of band bow fibulae, while with the Certosa fibulae it gained absolute primacy among the sites of Dolenjska. Magdalenska gora yielded two thirds of Type II, half of Types V and XIII and almost three quarters of Type X. Moreover, the site revealed the most exceptional pieces of figural fibulae (in the shape of a three-horse chariot, a horse) or with a decorative foot, but also kettledrum fibulae and iron Certosa fibulae.

The discussion above shows that Magdalenska gora enjoyed, possibly from the start, a pride of place in the connections with the communities to the west. This is understandable considering its geographic position. In the Late Hallstatt period, it may even have been one of the production centres for some of the types of Certosa fibulae (particularly Types X and XIII) and for the local kettledrum fibulae. The site also yielded Early La Tène forms of fibulae,¹¹¹⁸ as well as Late La Tène examples from graves that were subsequently dug into the tumuli and are not included in this discussion.¹¹¹⁹

¹¹¹⁸ Hencken 1978, Figs. 114e, 274d, 355a; Tecco Hvala/Dular/Kocuvan 2004, T. 138: 20.

¹¹¹⁹ Hencken 1978, Figs. 9a, 72a, 106b, 116b, 248d, 251b, 345a, 362d; Tecco Hvala/Dular/Kocuvan 2004, T. 2A, 10B, 19B: 8-10, 20A: 1, 31B: 1,2, 155: 14.

¹¹²⁰ Tecco Hvala/Dular/Kocuvan 2004, T. 148: 7,8.

¹¹²¹ Ibid., 88, sl. 42, 43, T. 143A, 147: 10, 148: 8. Glej tu poglavje 3.2.1 o žganih pokopih, sl. 24.

Sl. 101: Tipi bronastih polno ulitih ovratnic z Magdalenske gore. M. = 1:3.

Fig. 101: Types of solid bronze torques from Magdalenska gora. Scale = 1:3.

1 – Preloge, gr. 13/54 (**A1**); 2, 4 – Preloge, Tum. 2 (**A2**, T = tordirana / twisted); 3 – Preloge, gr. VIII/4 (**A2**);

5 – Preloge, gr. 2/73 (**B**); 6 – Preloge, gr. 2/67 (**C**); 7 – Preloge, gr. VI/1 (**D1**); 8 – Preloge, gr. XI/37 (**D2**);

9 – Laščik 1893/1 (**D2**); 10 – Preloge, gr. VII/40 (**D2**).

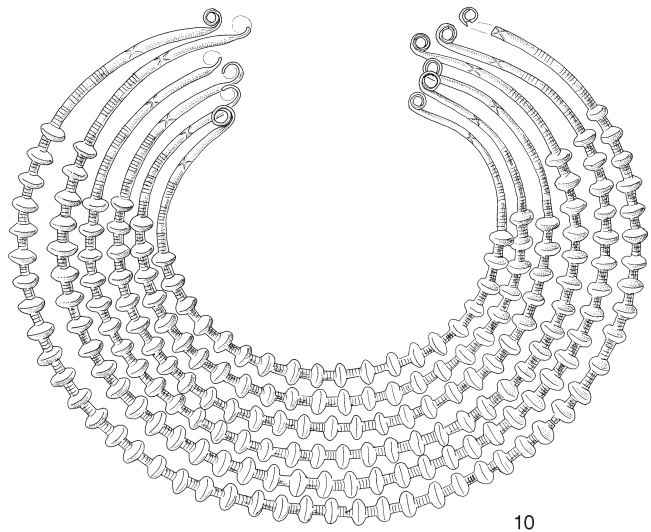
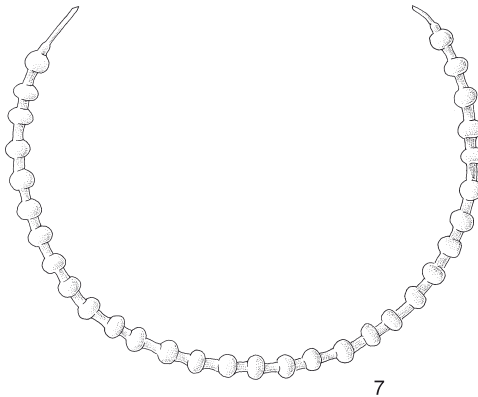
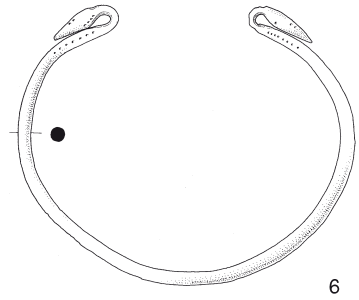
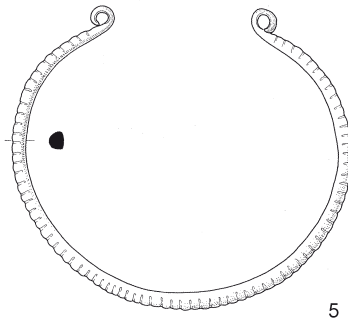
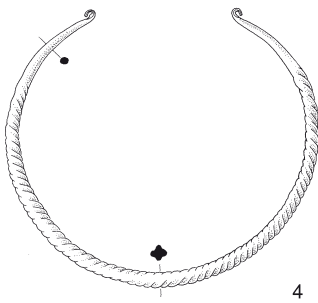
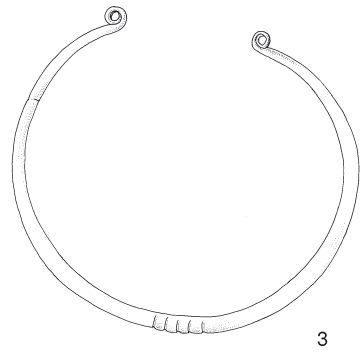
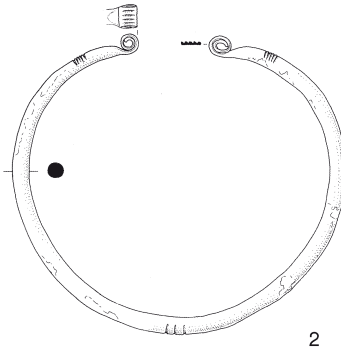
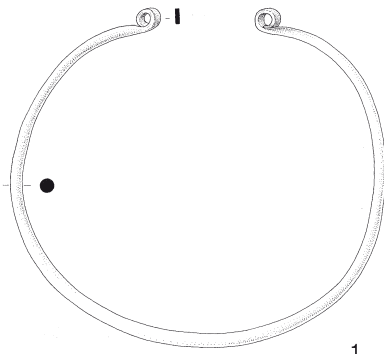

nih celot.¹¹²² Sodeč po njihovem premeru in zapiskih izkopavalcev so take ovratnice nosili otroci, v glavnem deklice. Le v grobni celoti 13/54 s Prelog nastopa skupaj z železno tulasto sekuro, o kateri je Brattina zapisal, da je ležala v zemlji 10 cm nad okostjem. Nekateri primerki gladkih ovratnic so okrašeni s snopi vrezov oz. reber, ki jih označujem kot različico **A2** (sl. 101: 2, 3).¹¹²³ Ena taka ovratnica je objavljena med pridatki groba VIII/4 s Prelog, ki je po zapiskih Goldberga vseboval fibulo s konjsko glavicico, ogrlico iz modrih in zelenih steklenih jagod, dve votli zapestnici in sceptor.

Vozlaste ovratnice različic **D1** in **D2** so večinoma pripadale ženskim opravam (sl. 101: 7–10 in sl. 103).¹¹²⁴ Komplet šestih takih ovratnic je krasil že večkrat omenjeno predstavnico stopnje Stična 2, pokopano v grobu VII/40 na Prelogah (sl. 101: 10). V ta čas bi nemara lahko opredelili tudi pokop deklice s tremi podobnimi ovratnicami (Laščik, gr. 1893/1), od katerih je ohranjena le ena (sl. 101: 9); razen tega je imela zapestnico in menda lepo fibulo, ki je manjkala že ob inventarizaciji predmetov v dunajskem muzeju. Vozlasti ovratnici iz groba VI/1 s Prelog (sl. 101: 7) bi lahko glede na velikost pripisali ženski noši; ena je brez dodatnega okrasa, druga je okrašena s pari reber med vozli ter šrafiranimi pasovi na prehodu v zaključka; najdeni pa sta bili menda skupaj z debelo jantarno ogrlico in kačasto fibulo. Večjih dimenzij sta tudi ovratnici iz grobov VII/49 in X/37 s Prelog, ki sta okrašeni z vrezi med vozli. K opravi pokojnice iz groba VII/49 naj bi spadala enozankasta fibula z listasto razširjenim lokom ter narebrena in gladka zapestnica, medtem ko naj bi pokojnica v grobu X/37 imela jantarno ogrlico in votlo gladko zapestnico. Ovratnico navaja Pečnik med pridatki otroškega groba iz gomile 2 na Prelogah (2/o), ki je vseboval živalski fibuli v obliki mačke in ptiča, drobne steklene jagode, zapestnico in nanožnico. Prav tako jo omenja v grobovih 8 in 14 na Laščiku, ki sta bila odkrita leta 1892. Te tri grobne celote niso ohranjene.

Narebren torkvez različice **B** (sl. 101: 5 in sl. 103) je edini tak primerek z Magdalenske gore.¹¹²⁵ Najden je bil v grobu 2/73 na Prelogah skupaj z železno rombično pasno spono, bronastim jezičkom z obročkom ter s trakasto fibulo. Morda jo je nosil deček, saj so pasne spone bolj značilne za moško nošo, enako velja za trakaste fibule. Unikatna ovratnica s stiliziranimi kačjima glavicama različice **C** (sl. 101: 6 in sl. 103)¹¹²⁶ pa je pripadala pokojnici v grobu 2/67 s Prelog skupaj z zapestnico s presegačimi konci, okrašeno s pasovi reber. Enkratni izdelek predstavlja tudi svinčen torkvez

¹¹²² Hencken 1978, Fig. 39c, 189d, 190d, 315f; Tecco Hvala/Dular/Kocuvan 2004, T. 49A: 1, 82C: 1, 147: 10, 11.

¹¹²³ Hencken 1978, Fig. 279a; Tecco Hvala/Dular/Kocuvan 2004, T. 147: 9.

¹¹²⁴ Hencken 1978, Fig. 172a,b, 261o, 270d, 328a; Tecco Hvala/Dular/Kocuvan 2004, T. 5B: 1, T. 147: 12, 13.

¹¹²⁵ Tecco Hvala/Dular/Kocuvan 2004, T. 60A: 1.

¹¹²⁶ *Ibid.*, T. 59: 1.

4.8 TORQUES AND NECKLACES

4.8.1 TORQUES

Typological characteristics. The torques recovered from the graves of Magdalenska gora are, with a single lead exception, made of bronze. They are of various sizes and production manners: some are solid with rolled ends (fig. 101), others are made of thin sheet bronze with solid spherical ends inserted into the tube and attached with a rivet (fig. 102). Further typological division is based on the decorative elements. The solid torques consist of plain wire examples, i.e. Variant **A1** (fig. 101: 1); examples decorated with stripes of incisions, i.e. Variant **A2** (fig. 101: 2, 3), and twisted examples (fig. 101: 4). One solid torque is ribbed and marked as Variant **B** (fig. 101: 5). The numerous knobbed examples are divided into Variant **D1** without other decoration (fig. 101: 7) and Variant **D2** with stripes of transverse incisions or narrow grooves between the knobs (fig. 101: 8–10). The unique torque with impressed dots and snake-headed terminals is marked as Variant **C** (fig. 101: 6). Another unique torque is the above-mentioned lead example (**Pb**), decorated with transverse incisions and dots (fig. 102: 6).

The hollow torques are usually undecorated (Variant **V3**). In rare examples they bear incisions (Variants **V2** and **V4**). Their terminals are spherical and solid cast (fig. 102: 2, 4, 5), while the ribbed example of Variant **V1** comes with rolled ends (fig. 102: 1). Found at Voselca was also a pair of cast animal-headed terminals (fig. 102: 3).

Position and context. The collection of the museum in Ljubljana includes two twisted torques; one with ends of round cross-section (fig. 101: 4), the other of rectangular cross-section.¹¹²⁰ For the latter, the noted findspot is a tumulus at Hrastje excavated by Schulz in 1882/83; this findspot is also shared by a plain torque. I presume that these two torques were actually found in urn Grave 6/1 at Voselca (fig. 24: d and fig. 103), which, according to Dežman, contained two torques inside a situla with painted red and black bands and covered with a bronze plate, two small amber spacer plates and beads as well as two bracelets.¹¹²¹

Plain wire torques of Variant **A1** were found in both cremation and inhumation graves (fig. 103), some were also documented as stray finds.¹¹²² Judging from their diameter and notes of the excavators, they were worn by children, mostly girls. Only in Grave 13/54 from Preloge was it found together with an iron socketed axe, of which Brattina wrote to have been laid 10cm above the skeleton. Several plain torques were decorated with stripes of in-

¹¹²⁰ Tecco Hvala/Dular/Kocuvan 2004, T. 148: 7, 8.

¹¹²¹ *Ibid.*, 88, Abb. 42, 43, T. 143A, 147: 10, 148: 8. See Chapter 3.2.1 on cremation burials, fig. 24.

¹¹²² Hencken 1978, Figs. 39c, 189d, 190d, 315f; Tecco Hvala/Dular/Kocuvan 2004, T. 49A: 1, 82C: 1, 147: 10, 11.

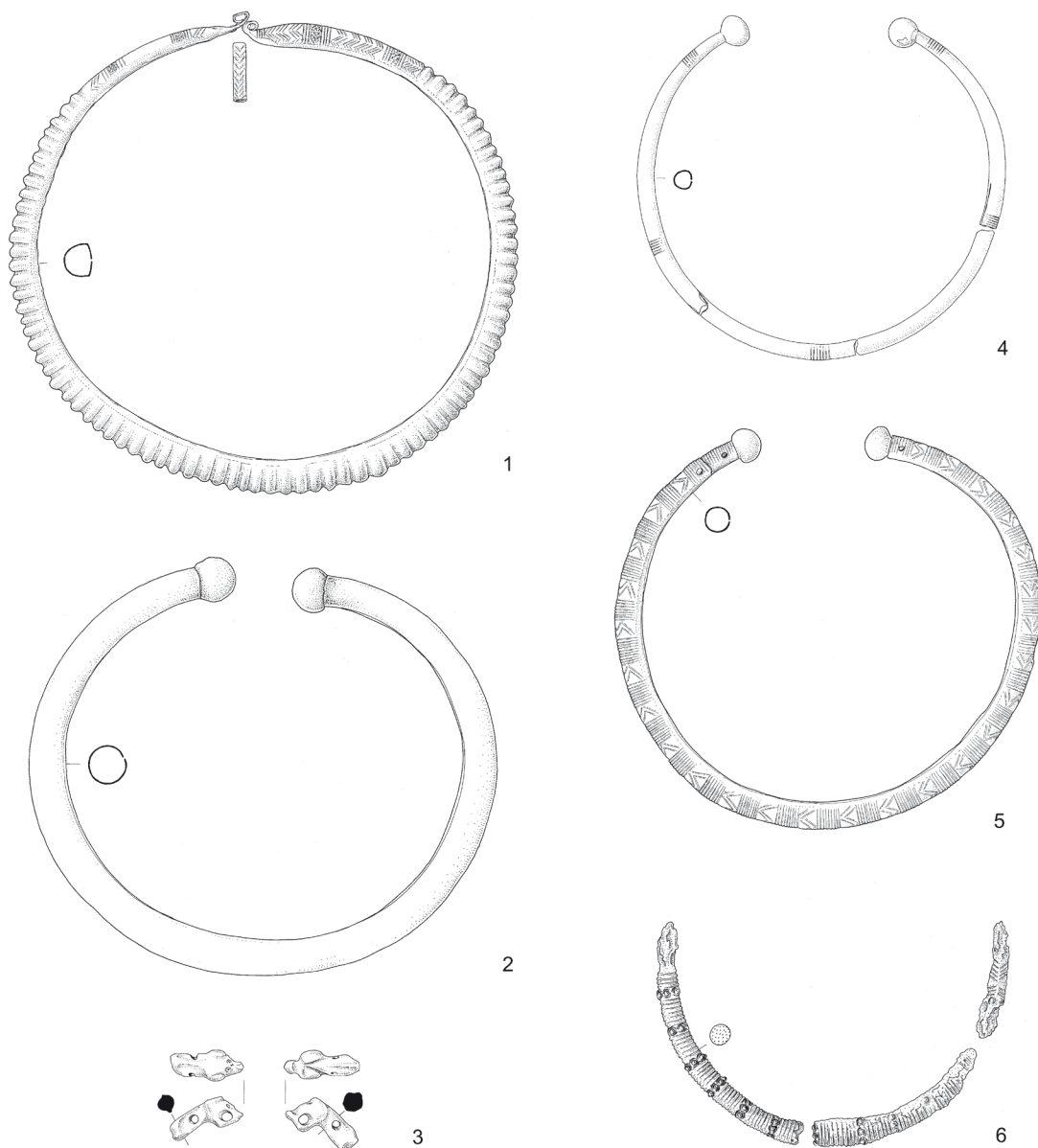

Sl. 102: Tipi bronastih votlih ovratic in svinčen primerek z Magdalenske gore. M. = 1:3.

Fig. 102: Types of hollow bronze torques and a solid lead example from Magdalenska gora. Scale = 1:3.

1 – Preloge, gr. 13/77 (V1); 2 – Preloge, gr. 2/4 (V3); 3 – Voselca, gr. 1/1 (bronasta polno ulita zaključka / solid cast bronze terminals); 4 – Preloge, gr. 13/162 (V2); 5 – Preloge, gr. 2/25 (V4); 6 – Voselca, gr. 2/7 (Pb).

(Pb), ki ga je nosila deklica, pokopana v grobu 2/7 na Voselci (sl. 102: 6 in sl. 103).¹¹²⁷

Večino votlih ovratic bi po dimenzijah lahko pripisali odraslim osebam. V grobu 13/77 s Prelog omenja Brattina dve okostji, ki sta ležali drugo ob drugem; manjše je imelo na rokah dve polni narebreni zapestnici, večje (ki je merilo 160 cm) pa jantarne jagode in šest velikih

cisions or ribs, marked as Variant A2 (fig. 101: 2, 3).¹¹²³ One such torque is published as part of Grave Group VIII/4 from Preloge, which, according to Goldberg, also contained a fibula with a horse's head, a necklace of blue and green glass beads, two hollow bracelets and a sceptre.

Knobbed torques of Variants D1 and D2 mostly formed part of the female costume (fig. 101: 7–10 and

¹¹²³ Hencken 1978, Fig. 279a; Tecco Hvala/Dular/Kocuvan 2004, T. 147: 9.

¹¹²⁷ Ibid., T. 132C: 2.

Gom. / Gr. Tum. / Gr.	Pokop / Burial rite	Spol / Starost Sex / Age	Tip ovratnic / Type of torques	Št. ovratnice / No. of torques	Fibule / Fibulae	Uhani / Earrings	Steklene jagode / Glass beads	Jantar / Amber	Zapestnice / Bracelets	Nanožnice / Anklets	Scepter / Sceptre	Pasne spono / Belts	Pasni okovi / Belt attachments	Sekire / Axes	Lončevina / Pottery	Vijčki / Spindle whorls	Bronasto posodje / Bronze vessels
V 6/1	C	F?	AI+T	2	3		x	x	2						1		1
P VI/16	C	I	AI	1					2						1		
P VI/15	C	I		1	1		1 br.								3		
P 2/55	S	I		1	1		1		1						1		
P 13/54	S	I?		1	2									1			
P X/24	S	I		1	2		x		2								
P VIII/4	S	I?	A2	1	1		x		2		1				1		
P 2/o	S	I	?	1	2		x		1	1							
L 1893/1	S	I	D2	3	1				1								
P VII/40	S	F		6	8	4	x	x	4+1	28						5	
P VII/49	S	F		1	1				2						1		
P X/37	S	F		1				x	1								
P VI/1	?	F?	D1+D2	2	1			x									
V 2/7	?	I	Pb	1	1				2						2		
P 2/73	S	I	B	1	1							Fe	1		1		
P 2/67	?	I	C	1						1							
P 13/77	S	A+I	VI	1			x	x	2+2			Fe					
P 13/162	S	I?	V2	1			x		x						2	6	
P 13/114	S	A+I	V2	1	2				2				1				
P 2/14	S	?	V?	1	2												
P 2/4	?	?	V3	1	2												
P 2/25	?	?	V4	1	2												

Sl. 103: Struktura pridatkov v grobovih z ovratnicami na Magdalenski gori. * = drugačen tip.

Fig. 103: Structure of goods in the graves with torques at Magdalenska gora. * = other type.

steklenih jagod, dve masivni narebreni zapestnici, železno pravokotno pasno spono, železen obroč, pri nogah pa votlo narebreno ovratnico z uvitima zaključkoma različice **V1** (sl. 102: 1 in sl. 103).¹¹²⁸

Različica **V2**, okrašena s snopi vrezov (sl. 102: 4 in sl. 103), je zastopana z dvema primerkoma.¹¹²⁹ V grobu 13/114 s Prelog je bila najdena na vratu večjega okostja, ki je imelo na vsaki roki po eno zapestnico, pod desnico pa majhno tulasto sekiro, razen tega sta mu pripadali še dve certoški fibuli vrste Xc, na katerih je ležala otroška lobanja. Gre torej za pokop odrasle osebe z otrokom, podobno kot v primeru groba 13/77 iz iste gomile. V obeh primerih je ovratnica pripadala

fig. 103).¹¹²⁴ A set of six adorned the often cited female representative of the Stična 2 phase buried in Grave VII/40 at Preloge (fig. 101: 10). Probably dating to the same phase is the burial of a girl with three similar torques (Laščik, Gr. 1893/1), only one of which has been preserved (fig. 101: 9). The girl was reportedly also buried with a bracelet and a beautiful fibula, but the latter had been missing already when the grave was inventoried in the museum in Vienna. The two knobbed torques from Grave VI/1 at Preloge (fig. 101: 7) could be attributed to the female costume on the basis of their size. One was without additional decoration, while the other has pairs of ribs between the knobs and hatched stripes towards the ends. They were reportedly

¹¹²⁸ Ibid., T. 91: 5.

¹¹²⁹ Ibid., T. 103C: 5; 121C: 1.

¹¹²⁴ Hencken 1978, Figs. 172a,b, 261o, 270d, 328a; Tecco Hvala/Dular/Kocuvan 2004, T. 5B: 1, T. 147: 12,13.

večjemu okostju in v obeh primerih se poleg ženskih pridatkov pojavljajo moški atributi, kot so železna pravokotna pasna spona, tulasta sekirica ter certoške fibule vrste X. Manjšo votlo ovratnico različice V2 pa zasledimo v dekliški opravi iz groba 13/162 iz te gomile, kjer nastopa skupaj s stekleno ogrlico, petimi vijčki in koščki bronastih zapestnic.

Na Magdalenski gori so zabeleženi tudi štirje neornamentirani primerki različice V3 (sl. 102: 2 in sl. 103),¹¹³⁰ vendar ne v okviru grobnih celot z izjemo groba 2/4 s Prelog, kjer nastopa s parom certoških fibul vrste XIII. Pečnik omenja votlo ovratnico še v grobu 2/14 iz iste gomile, ki je danes izgubljena, od pridatkov pa sta ohranjeni le dve certoški fibuli vrste I.¹¹³¹

Bogato okrašena različica V4 (sl. 102: 5 in sl. 103)¹¹³² spominja na votle zapestnice oz. nanožnice; najdena je bila v grobu 2/25 s Prelog v kombinaciji s parom certoških fibul vrste Xm.

Zaključka v obliki živalskih glav (sl. 102: 3), ki domnevno pripadata votli ovratnici, sta pripisana inventarju groba 1/1 z Voselce. To gomilo je Pečnik poskusno načel leta 1893 in v njej naletel na ženski in moški skelet, toda njegov seznam najdb ne ustreza zabeleženemu stanju v inventarni knjigi dunajskega muzeja.¹¹³³ Bronasto ovratnico navaja še med pridatki v enem od poznolatskih grobov (2/e in 2/f), ki sta bila naknadno vkopana v gomilo 2 na Prelogah.¹¹³⁴

Razširjenost in časovni okvir. Tordirane ovratnice so v jugovzhodnoalpskem svetu poznane že v obdobju kulture žarnih grobišč,¹¹³⁵ vendar jih na Dolenjskem zasledimo tudi na najdiščih iz starejše železne dobe, povečini brez ohranjenih grobnih celot (Vače, Magdalenska gora, Stična, Veliki Vinji vrh oz. Šmarjeta in Vinkov Vrh). Na Magdalenski gori je ena tordinarana ovratnica domnevno pripadala žarnemu

found together with a thick amber necklace and a serpentine fibula. The two torques from Graves VII/49 and X/37 from Preloge were also large. They are decorated with incisions between the knobs. The female in Grave VII/49 reportedly had, besides the torque, a single-looped fibula with a leaf bow as well as one ribbed and one plain bracelet. The female in Grave X/37, on the other hand, further had an amber necklace and a hollow plain bracelet. Another torque was reported by Pečnik among the goods in a child's grave from Tumulus 2 at Preloge (2/o), which further contained two figural fibulae, in the shape of a cat and a bird, respectively, small glass beads, a bracelet and an anklet. Pečnik also mentioned a torque in connection with Graves 8 and 14 from Laščik, which were found in 1892. The last three grave groups have not been preserved.

The ribbed torque of Variant B (fig. 101: 5 and fig. 103) is the only one of its kind at Magdalenska gora.¹¹²⁵ It was found in Grave 2/73 at Preloge together with an iron rhombic belt clasp, bronze attachment with a ring and a band bow fibula. It might have been worn by a boy, as suggested by the belt clasp that is more a male attribute; the same goes for the band bow fibula. The unique torque with stylized snake heads of Variant C (fig. 101: 6 and fig. 103)¹¹²⁶ belonged to the female buried in Grave 2/67 at Preloge together with a bracelet with overlapping ends and decorated with groups of ribs. The lead torque (Pb) was worn by the girl buried in Grave 2/7 at Voselca (fig. 102: 6 and fig. 103).¹¹²⁷

Most of the hollow torques could, on the basis of their size, be ascribed to adults. One was found in Grave 13/77 from Preloge, in which Brattina mentions two skeletons lying next to each other. The smaller skeleton had two solid ribbed bracelets on the arms, while the bigger one (160cm in length) had amber beads and six large glass beads, two solid ribbed bracelets, an iron rectangular belt clasp, an iron ring and a hollow ribbed torque with rolled ends of Variant VI, the latter at the feet (fig. 102: 1 and fig. 103).¹¹²⁸

Variant V2, decorated with stripes of incisions (fig. 102: 4 and fig. 103), is represented with two examples.¹¹²⁹ In Grave 13/114 at Preloge, it was found around the neck of a large skeleton, which further had a bracelet on each of the arms, a small socketed axe underneath the right arm, and two Certosa fibulae of Type Xc, on top of which lay a child's skull. This indicates a burial of an adult with a child, similarly as was observed in Grave 13/77 from the same tumulus. In both cases, the torque belonged to the larger skeleton and in both cases female attributes are combined with male ones, such as an iron rectangular belt clasp, a socketed axe and Type X Certosa fibulae. The second, smaller torque of Variant

¹¹³⁰ Hencken 1978, Fig. 170c; Tecco Hvala/Dular/Kocuvan 2004, T. 18A: 2, 148: 9, 10.

¹¹³¹ Tecco Hvala/Dular/Kocuvan 2004, 36, T. 20C.

¹¹³² Ibid., T. 30B: 1.

¹¹³³ Ibid., 81 s, T. 127: 14.

¹¹³⁴ Ibid., 30.

¹¹³⁵ Dobova: Stare F. 1975, T. 1: 14, 2: 10, 3: 1, 8: 8, 16: 3, 19: 5, 26: 7,8, 44: 3, 52: 4; *Golobinjek pri Šentjerneju*: Gabrovec 1973, T. 11: 6; *Veliki Korinj (depo)*: Čerče/Šinkovec 1995, T. 127B: 1; *Hočko Pohorje (depo)*: ibid., T. 79: 90; *Maribor*: Müller-Karpe 1959, T. 118: 44-46; *Maribor-Pobrežje*: Pahič 1972, T. 6: 17, 7: 10, 9: 4, 10: 14, 17: 11, 20: 10, 37: 7-9,13; *Mokronog*: Gabrovec 1973, T. 2: 1-8, 3: 1-3; *Novo mesto-Bršljin*: Križ 1995, kat. št. 9; *Novo mesto-Kapiteljska njiva*: Križ et al. 2009, 240 s, Kat. št. 29, 31; *Prečna*: Dular J. 2003, 174 s, T. 11: 4,5, Teržan 2009b; *Ptuj-Hajdina*: Müller-Karpe 1959, T. 116: 20; *Ruše*: ibid., T. 110A: 1, 110E: 6, 112A: 5, 112F: 1; *Škocjan-Brežec*: Ruaro Loseri et al. 1977, Tav. 4: 6, 8: 5, 9: 2, 14: 26-32, 27: 1-3,7, 25: 3, 30: 2; *Tolmin*: Svolfšak/Pogačnik 2001, T. 76: 3, 95: 6,7. Glej še Teržan 1985, 8 ss, Fig. 1: 4, 2: 1, 4: 5, 5: 3, 6: 2; ead. 1995a, 339; ead. 1999, 139, sl. 11-13.

¹¹²⁵ Tecco Hvala/Dular/Kocuvan 2004, T. 60A: 1.

¹¹²⁶ Ibid., T. 59: 1.

¹¹²⁷ Ibid., T. 132C: 2.

¹¹²⁸ Ibid., T. 91: 5.

¹¹²⁹ Ibid., T. 103C: 5; 121C: 1.

grobu 6/1 z Voselce iz časa stopnje Stična 2.¹¹³⁶ V bližnji Ljubljani so dokumentirane v desetih grobovih, ki kažejo časovni razpon njihove uporabe od stopnje Ljubljana I do IIIb.¹¹³⁷ Najmlajši med njimi je grob 267, v katerem nastopa tordiran torkvez v kombinaciji s številnimi gladkimi zapestnicami ali nanožnicami ter veliko čolničasto fibulo 3. skupine po Jerinovi. Skupaj s čolničasto fibulo t. i. šmarješkega tipa (= tip 2b po Jerinovi) je bila najdena tudi v Kranju.¹¹³⁸ V 7. st. pr. n. št. so se bronaste tordirane ovratnice nosile predvsem v svetolucijski skupnosti, kjer spadajo poleg vozlastih oblik med vodilne tipe stopnje Sv. Lucija Ic,¹¹³⁹ zato ne gre izključiti možne povezave omenjenega magdalenskogorskega groba 6/1 s tem kulturnim krogom; navsezadnje je šlo za žgani pokop v estensko situlo. Na drugi strani pa jih ob koncu 7. in na začetku 6. st. pr. n. št. zasledimo tudi v Dolnji Dolini v skeletnih¹¹⁴⁰ in žganih grobovih.¹¹⁴¹

Gladke žičnate ovratnice (različica A1) se v jugovzhodnih Alpah pojavljajo v planih žarnih grobiščih in v depojih,¹¹⁴² vendar so se v dolenski skupnosti obdržale še v železni dobi. V ljubljanski nekropoli na dvorišču SAZU je bil en tak primerek najden v grobu 214, ki je datiran v stopnjo Ljubljana IIIa (= stopnja Podzemelj 2).¹¹⁴³ Na Magdalenski gori so izpričane v žganih grobovih iz časa stopnje Stična,¹¹⁴⁴ pa tudi v skeletnih grobovih iz časa certoških fibul.¹¹⁴⁵ Podoben časovni razpon nakazujejo najdbe gladkih ovratnic z drugih dolenskih in belokranjskih najdišč, kjer se med

¹¹³⁶ *Magdalenska gora*: Tecco Hvala/Dular/Kocuvan 2004, T. 148: 7; *Stična*: Wells 1981, Fig. 165a; *Vače*: Stare F. 1955a, T. 61: 3 in neobjavljen primerek, NHMW inv.št. 7975; *Veliki Vinji vrh (Šmarjeta)*: Dular A. 1991, T. 6: 15,16; *Vinkov Vrh*: Stare V. 1964–1965, T. 14: 12.

¹¹³⁷ *Ljubljana-dvorišče SAZU*, gr. 10, 25, 39, 40, 64, 267, 301, 308, 313, 317: Stare F. 1954b, T. 10: 5, 22: 1, 36: 6, 38: 4, 54: 8; Puš 1982, T. 3: 5, 16: 9, 20: 8, 23: 6, 26: 2, 45: 2,5,6; Gabrovec 1973, 342 ss, tabela 1; Teržan 1987, 8 ss, Fig. 1: 4, 2: 1.

¹¹³⁸ Stare F. 1954d, T. 1: 5.

¹¹³⁹ Teržan/Trampuž 1973, 424 ss, pril. 1; Teržan/Lo Schiavo/Trampuž-Orel 1985, T. 11A: 3, 11I: 2, 19B: 3, 19F: 3, 40B: 10, 47B: 2, 56C: 3, 114F: 5, 127C: 3, 128G: 8, 134A: 2, 157A: 9, 190A: 12.

¹¹⁴⁰ *M. Petrović Jr.*, gr. 3, 6; *M. Petrović Sen.*, gr. 4, 9, 10; *N. Šokić*, gr. 1; *N. Šokić II*, gr. 2; *I. Stipančević*, gr. 8: Truhelka 1904, T. 40, 42: 15, 43: 12, 68: 13, 70: 19, 72: 6, 58: 16, 75: 5, 78: 2.

¹¹⁴¹ *M. Petrović Sen.*, gr. 6; *I. Petrović*, gr. 2: Truhelka 1904, T. 69: 8,13,15, 71: 1,2; Teržan 1974, 43; Čović 1987, 241.

¹¹⁴² *Dobova*: Stare F. 1975, T. 1: 15, 3: 2, 41: 4,10, 44: 9; *Ljubljana*: Stare F. 1954b, T. 26: 5, 69: 2; Puš 1971, 40: 7; Puš 1982, T. 45: 4, 52: 1. Srečamo jih tudi v podravske grobiščih, kot npr. *Maribor-Pobrežje*: Pahič 1972, 59, T. 8: 4, 19: 10, 22: 11, 37: 16; *Ptuj-Hajdina*: Müller-Karpe 1959, T. 116: 27, in v depoju *Hočko Pohorje* (Čerče/Šinkovec 1995, T. 79: 89), ki je datiran v Ha A (Gabrovec 1983, 72 ss, Turk 1996, 100).

¹¹⁴³ Puš 1971, T. 40: 7; Gabrovec 1973, tabela 1.

¹¹⁴⁴ *Preloge*, gr. VI/15, VI/16, VII/46; *Voselca*, gr. 6/1(?).

¹¹⁴⁵ *Preloge*, gr. X/24, 2/55, 13/54.

V2 was found with a girl buried in Grave 13/162 from the same tumulus, together with a glass necklace, five spindle whorls and pieces of bronze bracelets.

Four examples of the undecorated Variant V3 were documented at Magdalenska gora (fig. 102: 2 and fig. 103),¹¹³⁰ though only one comes with a known grave group. In Grave 2/4 from Preloge it was found together with a pair of Type XIII Certosa fibulae. Pečnik also mentions a hollow torque in Grave 2/14 from the same tumulus. The torque is now lost, while of the grave goods only two Certosa fibulae of Type I have been preserved.¹¹³¹

The richly decorated Variant V4 (fig. 102: 5 and fig. 103)¹¹³² is reminiscent of the hollow bracelets or anklets. One example of the variant was found in Grave 2/25 at Preloge in combination with a pair of Type Xm Certosa fibulae.

The animal-headed terminals (fig. 102: 3), which supposedly belonged to a hollow torque, are ascribed to Grave 1/1 from Voselca. Its tumulus was first tested by Pečnik in 1893 and revealed a female and a male skeleton, but his list of finds fails to correspond to the inventory book of the museum in Vienna.¹¹³³ Pečnik also mentions a bronze torque among the goods of one of the Late La Tène graves (2/e and 2/f) subsequently dug into Tumulus 2 at Preloge.¹¹³⁴

Distribution and time frame. Twisted torques were known in the south-eastern Alpine area already in the Urnfield culture period.¹¹³⁵ The examples of Iron Age date from Dolenjska are, unfortunately, mostly without preserved grave groups (Vače, Magdalenska gora, Stična, Veliki Vinji vrh (Šmarjeta), Vinkov Vrh). At Magdalenska gora, one twisted torque probably belonged to urn Grave 6/1 from Voselca, dated to the Stična 2 phase.¹¹³⁶ In

¹¹³⁰ Hencken 1978, Fig. 170c; Tecco Hvala/Dular/Kocuvan 2004, T. 18A: 2, 148: 9,10.

¹¹³¹ Tecco Hvala/Dular/Kocuvan 2004, 36, T. 20C.

¹¹³² *Ibid.*, T. 30B: 1.

¹¹³³ *Ibid.*, 81 f, T. 127: 14.

¹¹³⁴ *Ibid.*, 30.

¹¹³⁵ *Dobova*: Stare F. 1975, T. 1: 14, 2: 10, 3: 1, 8: 8, 16: 3, 19: 5, 26: 7,8, 44: 3, 52: 4; *Golobinjek near Šentjernej*: Gabrovec 1973, T. 11: 6; *Veliki Korinj (hoard)*: Čerče/Šinkovec 1995, T. 127B: 1; *Hočko Pohorje (hoard)*: *ibid.*, T. 79: 90; *Maribor*: Müller-Karpe 1959, T. 118: 44-46; *Maribor-Pobrežje*: Pahič 1972, T. 6: 17, 7: 10, 9: 4, 10: 14, 17: 11, 20: 10, 37: 7-9,13; *Mokronog*: Gabrovec 1973, T. 2: 1-8, 3: 1-3; *Novo mesto-Bršljin*: Križ 1995, Cat. No. 9; *Novo mesto-Kapiteljska njiva*: Križ et al. 2009, 240 s, Cat. Nos. 29, 31; *Prečna*: Dular J. 2003, 174 f, T. 11: 4,5, Teržan 2009b; *Ptuj-Hajdina*: Müller-Karpe 1959, T. 116: 20; *Ruše*: *ibid.*, T. 110A: 1, 110E: 6, 112A: 5, 112F: 1; *Škocjan-Brežec*: Ruaro Loseri et al. 1977, Tav. 4: 6, 8: 5, 9: 2, 14: 26-32, 27: 1-3,7, 25: 3, 30: 2; *Tolmin*: Svöljšak/Pogačnik 2001, T. 76: 3, 95: 6,7. See also Teržan 1985, 8 ff, Figs. 1: 4, 2: 1, 4: 5, 5: 3, 6: 2; *ead.* 1995a, 339; *ead.* 1999, 139, Figs. 11–13.

¹¹³⁶ *Magdalenska gora*: Tecco Hvala/Dular/Kocuvan 2004, T. 148: 7; *Stična*: Wells 1981, Fig. 165a; *Vače*: Stare F. 1955a, T. 61: 3 and an unpublished example, NHMW Inv. No.

najmlajše primerke uvršča ovratnica iz Valične vasi.¹¹⁴⁶ V Notranjsko-kraški regiji jih srečamo tako v žganih¹¹⁴⁷ kot v skeletnih grobovih iz stopenj Notranjska IIc do IIIb.¹¹⁴⁸ Zanimivo je, da je v svetolucijski skupnosti ta tip ovratnic redek,¹¹⁴⁹ čeprav so bili torkvezi tam priljubljeni nakit v starejšem halštatskem obdobju.

Masivne bronaste ovratnice, okrašene s pasovi reber oz. vrezov (različica **A2**), so redke.¹¹⁵⁰ V gomili v Volčjih Njivah jo zasledimo v otroškem grobu iz časa kačastih fibul,¹¹⁵¹ medtem ko bi magdalenskogorski primerek iz groba VIII/4 s Prelog lahko postavili v certoško stopnjo, saj Goldberg v tem grobu omenja fibulo s konjsko glavico.

Redke so tudi narebrenе ovratnice različice **B**.¹¹⁵² V gomili na Hribu nad Metliko je spadala v otroški skeletni grob, ki je datiran na konec stopnje Stična 2.¹¹⁵³ Grob 7/3 s tako ovratnico iz Brusnic sodi v prvo polovico 6. st. pr. n. št.,¹¹⁵⁴ v stopnjo kačastih fibul prav tako spada grob 2/73 s Prelog na Magdalenski gori, sodeč po trakasti fibuli med spremljajočimi pridatki.

Ovratnica z zaključki v obliki kačjih glavic (različica **C**) iz groba 2/67 s Prelog na Magdalenski gori ima najbližje paralele na Vačah¹¹⁵⁵ in v Zagorju.¹¹⁵⁶ Ta tip je glede na obliko zaključkov še najbolj podoben picenskim primerkom iz stopnje IVA po Lollinijevi.¹¹⁵⁷ Na drugi strani pa bi jih lahko slogovno primerjali z zapestnicami, zaključenimi z nazaj zavrtimi kačjimi glavicami, ki se

nearby Ljubljana, such torques were documented in ten graves that indicate a time span of their use from phases Ljubljana I to IIIb.¹¹³⁷ The latest among them is Grave 267, in which a twisted torque appears together with numerous plain bracelets or anklets as well as a large boat fibula of Group 3 after Jerin. It was found together with a boat fibula of Type Šmarjeta (2b after Jerin) at Kranj.¹¹³⁸ In the seventh century BC, bronze twisted torques were worn primarily in the Sveta Lucija community, where twisted and knobbed torques rank among the leading types of the Sv. Lucija Ic phase.¹¹³⁹ The possible connection of Grave 6/1 from Magdalenska gora to the above-mentioned cultural circle is therefore not to be excluded, particularly when bearing in mind that it was found in a cremation grave with remains placed inside an Este situla. On the other hand, it is also true that the twisted torques were found at Donja Dolina in both inhumation¹¹⁴⁰ and cremation graves,¹¹⁴¹ dating to the end of the seventh and the beginning of the sixth century BC.

Plain wire torques (Variant **A1**) appear in the south-eastern Alps in Urnfield cemeteries and in hoards,¹¹⁴² while the Dolenjska community continued using them into the Iron Age. One such example was found in Ljubljana, in Grave 214 of the SAZU Courtyard cemetery, which is dated to the Ljubljana IIIa phase (= Podzemelj 2).¹¹⁴³ At Magdalenska gora, they were recorded in cremation graves from the Stična phase,¹¹⁴⁴ but also in inhumation graves from the Certosa phase.¹¹⁴⁵ A similar time span can be observed for the finds of plain torques from other sites in Dolenjska and Bela krajina, with the torque from Valična vas being

7975; *Veliki Vinji vrh* (Šmarjeta): Dular A. 1991, T. 6: 15,16; *Vinkov Vrh*: Stare V. 1964–1965, T. 14: 12.

¹¹³⁷ *Ljubljana-SAZU courtyard*, Gr. 10, 25, 39, 40, 64, 267, 301, 308, 313, 317: Stare F. 1954b, T. 10: 5, 22: 1, 36: 6, 38: 4, 54: 8; Puš 1982, T. 3: 5, 16: 9, 20: 8, 23: 6, 26: 2, 45: 2,5,6; Gabrovec 1973, 342 ff, Tabelle 1; Teržan 1987, 8 ff, Figs. 1: 4, 2: 1.

¹¹³⁸ Stare F. 1954d, T. 1: 5.

¹¹³⁹ Teržan/Trampuž 1973, 424 ff, Allegato 1; Teržan/Lo Schiavo/Trampuž-Orel 1985, T. 11A: 3, 11I: 2, 19B: 3, 19F: 3, 40B: 10, 47B: 2, 56C: 3, 114F: 5, 127C: 3, 128G: 8, 134A: 2, 157A: 9, 190A: 12.

¹¹⁴⁰ *M. Petrović Jr.*, Gr. 3, 6; *M. Petrović Sen.*, Gr. 4, 9, 10; *N. Šokić*, Gr. 1; *N. Šokić II*, Gr. 2; *I. Stipančević*, Gr. 8: Truhelka 1904, T. 40, 42: 15, 43: 12, 68: 13, 70: 19, 72: 6, 58: 16, 75: 5, 78: 2.

¹¹⁴¹ *M. Petrović Sen.*, Gr. 6; *I. Petrović*, Gr. 2: Truhelka 1904, T. 69: 8,13,15, 71: 1,2; Teržan 1974, 43; Čović 1987, 241.

¹¹⁴² *Dobova*: Stare F. 1975, T. 1: 15, 3: 2, 41: 4,10, 44: 9; *Ljubljana*: Stare F. 1954b, T. 26: 5, 69: 2; Puš 1971, 40: 7; Puš 1982, T. 45: 4, 52: 1. They were also documented in the cemeteries along the Drava river, namely *Maribor-Pobrežje*: Pahič 1972, 59, T. 8: 4, 19: 10, 22: 11, 37: 16; *Ptuj-Hajdina*: Müller-Karpe 1959, T. 116: 27, and in the hoard from *Hočko Pohorje* (Čerče/Šinkovec 1995, T. 79: 89), dated to Ha A (Gabrovec 1983, 72 ff, Turk 1996, 100).

¹¹⁴³ Puš 1971, T. 40: 7; Gabrovec 1973, Tabelle 1.

¹¹⁴⁴ *Preloge*, Gr. VI/15, VI/16, VII/46; *Voselca*, Gr. 6/1(?).

¹¹⁴⁵ *Preloge*, Gr. X/24, 2/55, 13/54.

¹¹⁴⁶ *Dobrnich*: Stare V. 1973b, T. 6: 1; Parzinger 1988–1989, T. 19: 8, 25: 2; *Dragatuš*: Spitzer 1973, T. 19: 9; Škvor Jernejčič 2011, T. 15: 6; *Libna*: Guštin 1976, T. 8: 3, 34: 6, 73: 2,6; *Podzemelj*: Barth 1969, T. 23: 2; Dular J. 1978, T. 13: 5,7; *Stična*: Gabrovec et al. 2006, T. 127: 5, 148: 9,10, 186: 22; *Vače*: Stare F. 1955a, T. 60: 3,6, 61: 2, 64: 1 in neobjavljeni primerki, NHMW inv.št. 6742, 7912, 8541; *Valična vas*: Teržan 1973, T. 11: 30; *Veliki Vinji vrh* (Šmarjeta): Stare V. 1973a, T. 32: 23,29; Dular A. 1991, T. 55: 9, 73: 35,36; *Vinkov Vrh*: Stare V. 1964–1965, T. 14: 13; *Zagorje*: Gabrovec 1966b, T. 6: 5.

¹¹⁴⁷ *Škocjan-Brežec*, gr. 27, 28, 57, 231: Ruaro Loseri et al. 1977, Tav. 3: 1-3, 6: 3-8, 20: 2; *Šmihel-Pod Kaculjem*, gr. 53, *Pod Mačkovcem*, gr. 86, *Za Polšno*, gr. 94: Guštin 1979, T. 46: 1, 50: 12,22.

¹¹⁴⁸ *Križna gora*, gr. 115, 126: Urleb 1974, T. 23: 4, 25: 11.

¹¹⁴⁹ Teržan/Lo Sciavo/Trampuž Orel 1984, T. 40C: 2, 101D: 2, 129A: 11.

¹¹⁵⁰ *Ljubljana*: Puš 1982, T. 52: 2; *Podturn*: Dular J. 2003, T. 25: 4; *Podzemelj-Škrilje*: Barth 1969, T. 39: 2; *Rovišče*: Dular J. 2003, T. 77: 2; *Stična*: Wells 1981, Fig. 127b; *Volčje Njive*: Gabrovec 1956, T. 3: 3.

¹¹⁵¹ Gr. 3: Teržan 1976, 384, sl. 54: 1.

¹¹⁵² *Brusnice*: Teržan 1974, T. 4: 2; *Libna*: Guštin 1976, T. 49: 17; *Metlika-Hrib*: Grahek 2004, T. 3: 4; *Podzemelj*: Dular J. 1978, T. 13: 6,8; *Zagorica pri Čatežu*: Dular J. 2003, T. 40: 1.

¹¹⁵³ Gr. 18: Grahek 2004, 159, sl. 43, 44: A.

¹¹⁵⁴ Teržan 1974, 41, 45.

¹¹⁵⁵ Neobjavljen primerek, NHMW inv. št. 7976.

¹¹⁵⁶ Gabrovec 1966b, 28, op. 37, T. 6: 6.

¹¹⁵⁷ Lollini 1976, 135, Tav. X: 5,6,8; Morelli 2001, 326 ss, Fig. 68.

pojavnajo v drugi polovici 6. in v začetku 5. st. pr. n. št. v Padski nižini, Poadižju vse tja do Panonije.¹¹⁵⁸

Od zgornjega Poadižja do zahodne Panonije so bile razširjene tudi vozlaste ovratnice (tip D), kot je pokazala Teržanova; največja koncentracija in oblikovna pestrost pa je opazna v svetolucijskem krogu, kjer so značilne za nošo v stopnji Sv. Lucija Ic, vendar se pojavijo že prej.¹¹⁵⁹ Na teritoriju dolenske halštatske skupnosti so najstarejši primerki znani iz Bele krajini, kjer nastopajo v skeletnih gomilnih pokopih iz časa stopnje Podzemelj 2 in Stična 1.¹¹⁶⁰ Ovratnice iz teh grobov pripadajo različici **D1** brez dodatnih okrasnih vrezov, en primerek ima celo železno jedro,¹¹⁶¹ v železni izvedbi pa je znana na Budinjaku.¹¹⁶² Srečamo jih tudi v planih žarnih grobiščih v Sadežu pri Črnomlju¹¹⁶³ in v Ljubljani v času stopnje Ljubljana IIIb.¹¹⁶⁴ V stopnji Stična 2 so izpričane v skeletnih grobovih na Brezju in v Stični,¹¹⁶⁵ bržkone še mlajši je magdalenskogorski primerek, ki je bil najden v grobu VI/1 na Prelogah skupaj s kačasto fibulo.

Ovratnice različice **D2**, ki so okrašene s prečnimi vrezi med vozli, se na Magdalenski gori pojavljajo v grobovih iz stopenj Stična 2 in kačastih fibul. V ta čas sodi tudi grob šestletne deklice iz Velikih Malenc, ki je nosila tako ovratnico v kombinaciji z zlatimi okraski za diadem, z dvozankastima vozlastima fibulama in jantarno ogrlico,¹¹⁶⁶ medtem ko so primerki z drugih dolenskih in belokranjskih najdišč v glavnem brez ohranjenih grobnih celot.¹¹⁶⁷ V svetolucijski skupnosti so se podobne ovratnice nosile že v stopnji Sv. Lucija Ic1,¹¹⁶⁸ v poznem Ha C pa tudi npr. na štajerskem Rifniku.¹¹⁶⁹

Svinčen torkvez v opravi magdalenskogorske deklice nima primerjav, po okrasu je še najbližji vo-

among the latest examples.¹¹⁴⁶ In Notranjska and the Kras they were found in both cremation¹¹⁴⁷ and inhumation graves from phases Notranjska IIc to IIIb.¹¹⁴⁸ Interestingly, the torque type is rare in the Sveta Lucija community,¹¹⁴⁹ despite the fact that torques there were a popular item of dress in the Early Hallstatt period.

Solid bronze torques decorated with groups of ribs or incisions (Variant **A2**) are rare finds.¹¹⁵⁰ One was unearthed in a tumulus at Volčje Njive, in a child's grave from the Serpentine Fibulae phase.¹¹⁵¹ As for the example from Magdalenska gora, it was found in Grave VIII/4 at Preloge together with a fibula with a horse's head, as mentioned by Goldberg, which indicates the date into the Certosa phase.

Ribbed torques of Variant **B** were also rarely documented and found at several sites in southern Dolenjska and in Bela krajina.¹¹⁵² At Hrib near Metlika, it was found in a tumulus, in an inhumation burial of a child dated to the end of the Stična 2 phase.¹¹⁵³ The example from Brusnice was found in Grave 7/3 from the first half of the sixth century BC.¹¹⁵⁴ Also dating to the Serpentine Fibulae phase is Grave 2/73 from Preloge, as can be judged by the band bow fibula found together with the torque.

The torque with snake head terminals (Variant **C**) from Grave 2/67 at Preloge has parallels, within the Dolenjska community, only at Vače¹¹⁵⁵ and in Zagorje.¹¹⁵⁶ Based on the terminals, the type is closest to the torques from Picenum dated to Phase IVA after

¹¹⁵⁸ Nascimbene 2009, 219 ss, Fig. 71: 17 (različica B). Njen seznam (Tab. 33) bi lahko dopolnili še s primerkom iz Stične, gr. 48/33: Gabrovec et al. 2006, T. 25: 2; Teržan 2008, 289.

¹¹⁵⁹ Teržan/Trampuž 1973, 426, op. 26; Teržan 1990a, 99, karta 11.

¹¹⁶⁰ *Dragatuš*, gr. 15/1903: Spitzer 1973, T. 10: 2; Škvor Jernejčič 2011, T. 3: 7; *Loka pri Črnomlju*, gr. 1/1, 1/2, 2/1, 3/1, 4/1: Dular J. 1983, T. 1: 4, 3: 5, 5: 3, 6: 3,4, 8: 2, 13: 6; *Podzemelj*: id. 1978, T. 13: 2, 41: 2; *Pusti Gradac 6/5*: id. 2003, T. 46: 4.

¹¹⁶¹ Dular 1983, 221, T. 3: 3.

¹¹⁶² Škoberne 2002, 68, sl. 24–27.

¹¹⁶³ Dular J. 1979, 75, T. 13: 3,5.

¹¹⁶⁴ Puš 1982, T. 11: 5.

¹¹⁶⁵ *Brezje*, gr. 7/36: Kromer 1959a, T. 22: 5; *Stična*, gr. 48/87: Gabrovec et al. 2006, T. 51: 4.

¹¹⁶⁶ Guštin 1996, 120, 125, Abb. 6: 13.

¹¹⁶⁷ *Mokronog-Sv. Križ*: Dular J. 2003, T. 9: 5; *Podzemelj*: id. 1978, T. 13: 1,4; *Stična*: Gabrovec et al. 2006, T. 174: 63–65; Wells 1981, Fig. 177b; *Veliki Vinji vrh (Šmarjeta)*: Stare V. 1973a, T. 32: 28.

¹¹⁶⁸ *Most na Soči*, gr. 440: Teržan/Trampuž 1973, 424, T. 5: 1; Teržan/LoSchiavo/Trampuž-Orel 1984, T. 36E: 5.

¹¹⁶⁹ Teržan 1990a, 69, 94,99, sl. 22: 2; ead. 1995b, Abb. 28: 2.

¹¹⁴⁶ *Dobrnič*: Stare V. 1973b, T. 6: 1; Parzinger 1988–1989, T. 19: 8, 25: 2; *Dragatuš*: Spitzer 1973, T. 19: 9; Škvor Jernejčič 2011, T. 15: 6; *Libna*: Guštin 1976, T. 8: 3, 34: 6, 73: 2,6; *Podzemelj*: Barth 1969, T. 23: 2; Dular J. 1978, T. 13: 5,7; *Stična*: Gabrovec et al. 2006, T. 127: 5, 148: 9,10, 186: 22; *Vače*: Stare F. 1955a, T. 60: 3,6, 61: 2, 64: 1 and unpublished examples, NHMW Inv. Nos. 6742, 7912, 8541; *Valična vas*: Teržan 1973, T. 11: 30; *Veliki Vinji vrh (Šmarjeta)*: Stare V. 1973a, T. 32: 23,29; Dular A. 1991, T. 55: 9, 73: 35,36; *Vinkov Vrh*: Stare V. 1964–1965, T. 14: 13; *Zagorje*: Gabrovec 1966b, T. 6: 5.

¹¹⁴⁷ *Škocjan-Brezec*, Gr. 27, 28, 57, 231: Ruaro Loseri et al. 1977, Tav. 3: 1–3, 6: 3–8, 20: 2; *Šmihel-Pod Kaculjem*, Gr. 53, *Pod Mačkovcem*, Gr. 86, *Za Polšno*, Gr. 94: Guštin 1979, T. 46: 1, 50: 12,22.

¹¹⁴⁸ *Križna gora*, Gr. 115, 126: Urleb 1974, T. 23: 4, 25: 11.

¹¹⁴⁹ Teržan/Lo Sciavo/Trampuž Orel 1984, T. 40C: 2, 101D: 2, 129A: 11.

¹¹⁵⁰ *Ljubljana*: Puš 1982, T. 52: 2; *Podturn*: Dular J. 2003, T. 25: 4; *Podzemelj-Škrilje*: Barth 1969, T. 39: 2; *Rovišče*: Dular J. 2003, T. 77: 2; *Stična*: Wells 1981, Fig. 127b; *Volčje Njive*: Gabrovec 1956, T. 3: 3.

¹¹⁵¹ Gr. 3: Teržan 1976, 384, Abb. 54: 1.

¹¹⁵² *Brusnice*: Teržan 1974, T. 4: 2; *Libna*: Guštin 1976, T. 49: 17; *Metlika-Hrib*: Grahek 2004, T. 3: 4; *Podzemelj*: Dular J. 1978, T. 13: 6,8; *Zagorica pri Čatežu*: Dular J. 2003, T. 40: 1.

¹¹⁵³ Gr. 18: Grahek 2004, 159, Figs. 43, 44: A.

¹¹⁵⁴ Teržan 1974, 41, 45.

¹¹⁵⁵ Unpublished example, NHMW Inv. No. 7976.

¹¹⁵⁶ Gabrovec 1966b, 28, n. 37, T. 6: 6.

tlim zapestnicam iz zgodnje negovske stopnje,¹¹⁷⁰ po materialu pa svinčnim zapestnicam, ki se prav tako pojavijo v tem času. V Novem mestu je bila najdena slabo ohranjena kositrna otroška ovratnica,¹¹⁷¹ ki kaže, da so tovrstno okrasje izdelovali tudi iz drugih kovin.

Drugo skupino ovratnic tvorijo primerki, izdelani iz cevasto ukrivljene bronaste pločevine. Te so povečini večjega premera in imajo vdete kroglaste zaključke. Narebrena votla ovratnica različice V1 z Magdalenske gore nima primerjav; po okrasu in zaključkih, uvitih v zanko, pa se navezuje na polno ulite izdelke. Nekaj več je gladkih torkvezov brez okrasa različice V3 ter okrašenih s snopi prečnih vrezov različice V2. Ti se sodeč po spremnih najdbah pojavljajo vse mlajše halštatsko obdobje,¹¹⁷² mestoma jih zasledimo celo v kombinaciji z orožjem (Brezje, gr. 7/1; Novo mesto-Znančeve njive, gr. 3/2). Zaključki pri teh ovratnicah so različno izdelani, na njih so pritrjena ušesca, drugi so votli in niso vstavljeni v cevast obroč, temveč so s strani nataktnjeni nanj.¹¹⁷³

Zaključka ulita v obliki stilizirane živalske glavi, ki izvirata iz gomile 1 na Voselci pod Magdalensko goro, imata najboljšo analogijo v grobu 2337 z Mosta na Soči,¹¹⁷⁴ kjer gre prav tako za fragment, ki pa vendarle jasno kaže, da je pripadal votli ovratnici. V tem grobu je bila še certoška fibula vrste VIIb, košarast obesek in obroček z izrastki, kar daje dobro oporo za kronološko opredelitev v stopnjo Sv. Lucija Iic.¹¹⁷⁵ Na Mostu na Soči se sorodna zaključka pojavljata še v poznolatskem okolju in se nemara navezujeta na mladohalštatsko tradicijo.¹¹⁷⁶

Magdalenska gora po številu ovratnic in pestrosti oblik prednjači pred drugimi dolenskim halštatskimi najdišči. V skupnem seštevku je delež magdalensko-gorskih primerkov 30-odstoten. Od gladkih ovratnic je prispevala četrtno, od vozlastih tretjino, od votlih pa kar polovico. Vendar s tega najdišča niso znani železni torkvezi, ki so se nosili v času stopenj Ljubljana Iib in

¹¹⁷⁰ *Dolenske Toplice*: Teržan 1976, T. 58: 6,7; *Novo mesto-Znančeve njive*: Knez 1986, T. 36: 8,9.

¹¹⁷¹ *Kapiteljska njiva*, gr. 2/5: Križ 1997, T. 4: 5.

¹¹⁷² *Brezje*, gr. 7/1, 7/8, 7/23: Kromer 1959a, T. 21: 1, 23; 26: 8; *Libna*: Guštin 1976, T. 15: 10,11, 73: 12; *Novo mesto-Znančeve njive*, gr. 3/2: Knez 1986, T. 23: 12; *Vače*: neobjavljeni primerki, NHMW inv. št. 7978; *Veliki Vinji vrh (Šmarjeta)*: Stare V. 1973a, T. 61: 1; Dular A. 1991, T. 64: 27; *Vinkov Vrh*: Stare V. 1964–1965, T. 14: 1. Votla ovratnica različice V3 je znana tudi iz Hallstatta (Kromer 1959b, T. 24: 2), različica V4 pa iz Notranjske – Čepna pri Knežaku (Guštin 1979, T. 4: 2).

¹¹⁷³ Kromer 1959a, T. 21: 1, 26: 8; Guštin 1976, T. 15: 10, 73: 12.

¹¹⁷⁴ Teržan/Lo Schiavo/Trampuž-Orel 1984, T. 246C: 5.

¹¹⁷⁵ Teržan 1976, 357.

¹¹⁷⁶ Mlinar 2009, 221, Fig. 4: 3, 5.

Lollini.¹¹⁵⁷ On the basis of style, on the other hand, they might be compared to the bracelets with terminals with backward-facing snake heads. The latter appear in the second half of the sixth and the beginning of the fifth century in the area extending from the Po Plain and the Adige basin to Pannonia.¹¹⁵⁸

Also spread from the Adige basin to western Pannonia were the knobbed torques of Variants D, as shown by Teržan. Their greatest concentration and formal variety was observed in the Sveta Lucija circle, where they characterize the costume of the Sv. Lucija Ic phase, possibly even earlier.¹¹⁵⁹ On the territory of the Dolenska Hallstatt community, the earliest examples are known from Bela krajina, where they were unearthed in inhumation burials into tumuli from the Podzemelj 2 and Stična 1 phases.¹¹⁶⁰ Torques from these graves are of Variant D1 without additional decorative incisions. One example has an iron core,¹¹⁶¹ while a torque made entirely of iron was found at Budinjak.¹¹⁶² They were also found in flat cemeteries with urn graves at Sadež near Črnomelj¹¹⁶³ and Ljubljana, dated to the Ljubljana IIIb phase.¹¹⁶⁴ Dating to the Stična 2 phase are the examples found in inhumation graves at Brezje and Stična,¹¹⁶⁵ while possibly even later is the example from Grave VI/1 at Preloge found together with a serpentine fibula.

Torques of Variant D2, decorated with transverse incisions between the knobs, appear at Magdalenska gora in the graves from the Stična 2 and Serpentine Fibulae phases. The time frame is shared by the burial of a 6-year-old girl from Velike Malence, who wore this type of a torque in combination with gold diadem adornments, a pair of two-looped knobbed fibulae and an amber necklace.¹¹⁶⁶ Other examples from Dolenska and Bela krajina are for the most part without preserved grave groups.¹¹⁶⁷ In the Sveta Lucija community, similar torques were worn

¹¹⁵⁷ Lollini 1976, 135, Tav. X: 5,6,8; Morelli 2001, 326 ff, Fig. 68.

¹¹⁵⁸ Nascimbene 2009, 219 ff, Fig. 71: 17 (Variant B). Her catalogue (Tab. 33) could be completed with an example from Stična, Gr. 48/33: Gabrovec *et al.* 2006, T. 25: 2; Teržan 2008, 289.

¹¹⁵⁹ Teržan/Trampuž 1973, 426, n. 26; Teržan 1990a, 99, map 11.

¹¹⁶⁰ *Dragatuš*, Gr. 15/1903: Spitzer 1973, T. 10: 2; Škvor Jernejčič 2011, T. 3: 7; *Loka pri Črnomlju*, Gr. 1/1, 1/2, 2/1, 3/1, 4/1: Dular J. 1983, T. 1: 4, 3: 5, 5: 3, 6: 3,4, 8: 2, 13: 6; *Podzemelj*: *id.* 1978, T. 13: 2, 41: 2; *Pusti Gradac 6/5*: *id.* 2003, T. 46: 4.

¹¹⁶¹ Dular 1983, 221, T. 3: 3.

¹¹⁶² Škoberne 2002, 68, Figs. 24–27.

¹¹⁶³ Dular J. 1979, 75, T. 13: 3,5.

¹¹⁶⁴ Puš 1982, T. 11: 5.

¹¹⁶⁵ *Brezje*, Gr. 7/36: Kromer 1959a, T. 22: 5; *Stična*, Gr. 48/87: Gabrovec *et al.* 2006, T. 51: 4.

¹¹⁶⁶ Guštin 1996, 120, 125, Abb. 6: 13.

¹¹⁶⁷ *Mokronog-Sv. Križ*: Dular J. 2003, T. 9: 5; *Podzemelj*: *id.* 1978, T. 13: 1,4; *Stična*: Gabrovec *et al.* 2006, T. 174: 63–65; Wells 1981, Fig. 177b; *Veliki Vinji vrh (Šmarjeta)*: Stare V. 1973a, T. 32: 28.

IIIa (= stopnja Podzemelj).¹¹⁷⁷ Najstarejše magdalensko-gorske grobove z ovratnicami lahko datiramo v stopnjo Stična, ko so bile v uporabi masivne gladke ali vozlaste različice (A1 in D2), pa tudi tordirane. Opravo vodilne predstavnice te stopnje s šestimi ovratnicami (Preloge, gr. VII/40) bi lahko razumeli kot reminiscenco na nošo iz časa kulture žarnih grobišč, čeprav ne gre za isti tip torkvezov.¹¹⁷⁸ Na to tradicijo se nemara navezuje tudi zapestnica z rombičnim presekom, okrašena s snopi poševnih vrezov, ki je bila najdena pri pokojničnih nogah in je sedeč po velikosti pripadala otroku.¹¹⁷⁹ Med magdalenskogorskimi primerki nastopajo tudi nekateri redki kosi, kot so ovratnica s kačastimi zaključki, svinčen torkvez, votla narebrena ovratnica različice V1 ter zaključka v obliki živalskih glav, ki spadajo k opravam iz mlajšega halštatskega obdobja. Na podoben način je bilo izdelano še drugo okrasje iz tega časa (npr. zapestnice in nanožnice), kar namiguje na lokalno delavnico, čeprav zanjo nimamo neposrednega dokaza.

4.8.2 OGRVICE

JANTARNE OGRVICE

Jantar je zanimiv že sam po sebi, ker gre za tuje-rodno snov in je zato neposreden indikator vključevanja v trgovske oz. menjalne tokove. Po dosedanjih ugotovitvah je baltskega izvora in markira t. i. jantarno pot med Severnim in Sredozemskim morjem.¹¹⁸⁰ O najstarejšem pojavu jantarja v jugovzhodnoalpskem svetu je pisala že Teržanova v zvezi z depojem iz Debelega vrha pri Pregradu iz časa Ha A, v katerem so bile najdene jagode tipa Tiryns.¹¹⁸¹ Na svojstven način se je vrednotenja jantarja lotil Wells v razpravi o železnodobni ekonomiji v vzhodnih Alpah.¹¹⁸² Primerjal je zastopanost te tvarine v žarnogrobiščnih in halštatskih nekropolah. Za vzorec z območja Dolenjske je vzel halštatske grobove iz Stične

¹¹⁷⁷ Gabrovec 1973, 343, 357; id. 1983, 68; id. 1987, 41, sl. 1: 21; Dular J. 2003, 102, 109, sl. 55: 6,12,13, 55: 1,14,15, 56: 17, 59: 10,16, 63: 2.

¹¹⁷⁸ Npr. Ormož gr. 7, Dobova, gr. 1982/33, 289, Velika gorica, gr. 3/1916, Cazin-Ostrožac, Jezerine, Kompolje, gr. 21, 43. Glej Tomanič-Jevremov 1988–1989, T. 17: 5; Teržan 1987, Fig. 4; ead. 1995a, Abb. 13, 27; ead. 1999, sl. 11; Ložnjak Dizdar 2009, 161 ss, karta 1.

¹¹⁷⁹ Hencken 1978, Fig. 262. Za zapestnice glej primerjave npr. Ruše: Müller-Karpe 1959, T. 110E: 1,2 111A: 5; Pobrežje: Pahič 1972, T. 38: 19; Ormož: Tomanič-Jevremov 1988–1989, T. 15: 4.

¹¹⁸⁰ Hadži/Orel 1978; Teržan 1984b; Mastrocinque 1991; Beck et al. (ur.) 1993; Palavestra 1993; Negroni Catacchio 1999, Fig. 1; ead. 2003; Palavestra/Krstić 2006; d'Ercole 2008.

¹¹⁸¹ Hirschbäck-Merhar 1984, T. 9: 17; Teržan 1984b; ead. 1995a, 355 s, Abb. 24; ead. 1996a, 250 s; Čerče/Šinkovec 1995, 159 ss, T. 66: 66; Turk 1996a, 102, 108 ss.

¹¹⁸² Wells 1981, 111 s, Fig. XXVI, Tab. 6, 10.

already in the Sv. Lucija Ic1 phase,¹¹⁶⁸ while they were in use at Rifnik in Štajerska in late Ha C.¹¹⁶⁹

A lead torque worn by the girl from Magdalenska gora is without parallels, in its decoration being closest to the hollow bracelets from the Early Negova phase,¹¹⁷⁰ and in its material to the lead bracelets of the same date. At Novo mesto, a poorly preserved child's torque made of tin was found,¹¹⁷¹ showing that this type of jewellery was also made of other metals.

The second group of torques are those made of curved tubes of sheet bronze. These are predominantly of large diameters with spherical terminals inserted in the ends. The ribbed hollow torque of Variant V1 from Magdalenska gora is without analogies, though in its decoration and rolled ends it comes close to the solid cast examples. Somewhat better represented are the plain torques of Variant V3 and those decorated with stripes of transverse incisions of Variant V2. The associated grave goods show that these two variants were in use throughout the Late Hallstatt period.¹¹⁷² They sometimes appear in combination with weapons (Brezje, Gr. 7/1; Novo mesto-Znančeve njive, Gr. 3/2). Their terminals are variously shaped, some with attached ears, others hollow and not inserted into the tubular body but rather attached to it from the side.¹¹⁷³

The two cast terminals in the shape of a stylized animal head, found in Tumulus 1 at Voseleca, have the closest analogy in the fragment from Grave 2337 at Most na Soči,¹¹⁷⁴ which clearly belonged to a hollow torque as well. The latter grave further yielded a Type VIIIb Certosa fibula, a basket-shaped pendant and a small ring with protrusions, which point to a Sv. Lucija Ic date.¹¹⁷⁵ Two similar terminals from Most na Soči were found in a Late La Tène context and might represent the remnants of the Late Hallstatt tradition.¹¹⁷⁶

In the number of torques and their formal variety, Magdalenska gora has the primacy over other Early Iron

¹¹⁶⁸ Most na Soči, Gr. 440: Teržan/Trampuž 1973, 424, T. 5: 1; Teržan/LoSchiavo/Trampuž-Orel 1984, T. 36E: 5.

¹¹⁶⁹ Teržan 1990a, 69, 94,99, Fig. 22: 2; ead. 1995b, Abb. 28: 2.

¹¹⁷⁰ Dolenjske Toplice: Teržan 1976, T. 58: 6,7; Novo mesto-Znančeve njive: Knez 1986, T. 36: 8,9.

¹¹⁷¹ Kapiteljska njiva, Gr. 2/5: Križ 1997, T. 4: 5.

¹¹⁷² Brezje, Gr. 7/1, 7/8, 7/23: Kromer 1959a, T. 21: 1, 23: 2; 26: 8; Libna: Guštin 1976, T. 15: 10,11, 73: 12; Novo mesto-Znančeve njive, Gr. 3/2: Knez 1986, T. 23: 12; Vače: unpublished example, NHMW Inv. No. 7978; Veliki Vinji vrh (Šmarjeta): Stare V. 1973a, T. 61: 1; Dular A. 1991, T. 64: 27; Vinkov Vrh: Stare V. 1964–1965, T. 14: 1. A hollow torque of Variant V3 is also known from Hallstatt (Kromer 1959b, T. 24: 2), and another of Variant V4 from Notranjska – Čepna near Knežak (Guštin 1979, T. 4: 2).

¹¹⁷³ Kromer 1959a, T. 21: 1, 26: 8; Guštin 1976, T. 15: 10, 73: 12.

¹¹⁷⁴ Teržan/Lo Schiavo/Trampuž-Orel 1984, T. 246C: 5.

¹¹⁷⁵ Teržan 1976, 357.

¹¹⁷⁶ Mlinar 2009, 221, Figs. 4: 3, 5.

Grobišče / gom. Cemetery / Tumulus	Delež gr. z jantarjem Percentage of gr. with amber	Delež gr. s steklom Percentage of gr. with glass beads
Laščik / V	17,3 %	5,8 %
Preloge / 2	16,5 %	20,4 %
Preloge / IV	13,6 %	1,5 %
Preloge / VI	14,6 %	4,2 %
Preloge / VII	17 %	11,3 %
Preloge / X	14,1 %	11,5 %
Preloge / 13	14,3 %	16 %
Voselca / 2	24 %	20 %

Sl. 104: Delež grobov z jantarnimi in steklenimi ogrlicami po posameznih gomilah na Magdalenski gori.

Fig. 104: Shares of graves with amber and glass jewellery in individual tumuli at Magdalenska gora.

in Magdalenske gore, ki jih je odkrila vojvodinja Mecklenburška, ter žarnogrobiščni nekropoli v Dobovi in Novem mestu. Ta primerjava na eni strani kaže, da v grobovih iz pozne bronaste dobe jantarja ni, na drugi strani pa so v halštatskem času med posameznimi najdišči vzhodnoalpskega sveta opazne velike razlike v količini jantarja. Med njimi prednjači Stična, sledita ji Magdalenska gora in Hallstatt ter s precej manjšim deležem še Križna gora in Welzelach. Leta 1993 je izšla temeljna študija o prazgodovinskem jantaru na centralnem in zahodnem Balkanu izpod peresa Palavestre, ki je najdbe iz te snovi predstavil z več vidikov: kulturno-historično, tipološko, analitično-kataloško, kronološko ter z vidika razprostranjenosti in komunikacij oz. menjalnih tokov. V dodatku je tipološko opredelil tudi tovrstne najdbe z ozemlja Slovenije in jih vključil v pregledne tipološke in kronološke karte.¹¹⁸³ Ker tedaj še ni bilo objavljeno gradivo moderno raziskanih gomil v Stični,¹¹⁸⁴ prav tako ne predmeti z Magdalenske gore, ki jih hranita dunajski in ljubljanski muzej,¹¹⁸⁵ je iz teh najdišč upošteval le najdbe iz Peabodyjevega muzeja.¹¹⁸⁶ Poleg tega je pozneje izšlo še nekaj katalogov gradiva iz novomeških gomil.¹¹⁸⁷ Kljub temu predstavlja Palavestrova študija temeljni prikaz tega fenomena ne le na vzhodnem Jadranu in Balkanu, temveč tudi na območju današnje Slovenije.

Če se osredotočim na Magdalensko goro, je že iz dosedanjega pregleda grobnih celot razvidno, da je bil jantar zelo priljubljen zaščitni znak deklet in žena. Deleži jantarnega nakita po posameznih gomilah so dokaj izenačeni (sl. 104), pri čemer je potrebno komentirati razliko v

Age sites of Dolenjska. It yielded 30 per cent of all types in Dolenjska, whereby it revealed one fourth of all plain, one third of all knobbed and as much as a half of all hollow examples. The torques not known at Magdalenska gora are those made of iron, which were in use in the Ljubljana IIb and IIIa phases (= Podzemelj).¹¹⁷⁷ The earliest graves at Magdalenska gora with torques can be dated to the Stična phase. Typologically, these are plain, solid and knobbed (Variants A1 and D2), but also twisted. The costume of the leading female representative of the phase with six torques (Preloge, Gr. VII/40) seems reminiscent of the costume of the Urnfield culture period in spite of the difference in the torque type.¹¹⁷⁸ This tradition might also have been the backdrop for the bracelet with a rhombic cross-section and stripes of oblique incisions, which was found at her feet and, considering its size, must have belonged to a child.¹¹⁷⁹ As shown above, the material from Magdalenska gora includes rare pieces, such as the torque with snake-headed terminals, the lead torque, the hollow ribbed torque of Variant V1 and the two animal-headed terminals, which all formed part of the costume of the Late Hallstatt period. Their manner of production can also be observed on other adornments of the period (such as bracelets and anklets), which suggests a local workshop. The existence of the latter, however, cannot be confirmed by direct evidence.

4.8.2 NECKLACES

AMBER NECKLACES

The interest of objects made of amber lies firstly in the material, since it is not available locally and therefore inevitably serves as an indicator of the trading and exchange routes. According to what is known thus far, the amber is of Baltic origin and travelled along the so-called Amber Route that connected the North and the Mediterranean Seas.¹¹⁸⁰ The earliest appearance of amber in the south-eastern Alps was discussed already by Teržan in connection with the hoard of Ha A date

¹¹⁷⁷ Gabrovec 1973, 343, 357; *id.* 1983, 68; *id.* 1987, 41, fig. 1: 21; Dular J. 2003, 102, 109, Abb. 55: 6,12,13, 55: 1,14,15, 56: 17, 59: 10,16, 63: 2.

¹¹⁷⁸ For example Ormož Gr. 7, Dobova, Gr. 1982/33, 289, Velika gorica, Gr. 3/1916, Cazin-Ostrožac, Jezerine, Kompolje, Gr. 21, 43. See Tomanič-Jevremov 1988–1989, T. 17: 5; Teržan 1987, Fig. 4; *ead.* 1995a, Abb. 13, 27; *ead.* 1999, Fig. 11; Ložnjak Dizdar 2009, 161 ff, map 1.

¹¹⁷⁹ Hencken 1978, Fig. 262. The bracelet is comparable to examples from Ruše: Müller-Karpe 1959, T. 110E: 1,2 111A: 5; *Pobrezje*: Pahič 1972, T. 38: 19; Ormož: Tomanič-Jevremov 1988–1989, T. 15: 4.

¹¹⁸⁰ Hadži/Orel 1978; Teržan 1984b; Mastrocinque 1991; Beck *et al.* (eds.) 1993; Palavestra 1993; Negroni Catacchio 1999, Fig. 1; *ead.* 2003; Palavestra/Krstić 2006; d'Ercole 2008.

¹¹⁸³ Palavestra 1993, 172 ss.

¹¹⁸⁴ Gabrovec *et al.* 2006.

¹¹⁸⁵ Tecco Hvala/Dular/Kocuvan 2004.

¹¹⁸⁶ Hencken 1978; Wells 1981.

¹¹⁸⁷ Knez 1993; Križ 1997; *id.* 2000; *id.* 2005; Križ/Turk 2003.

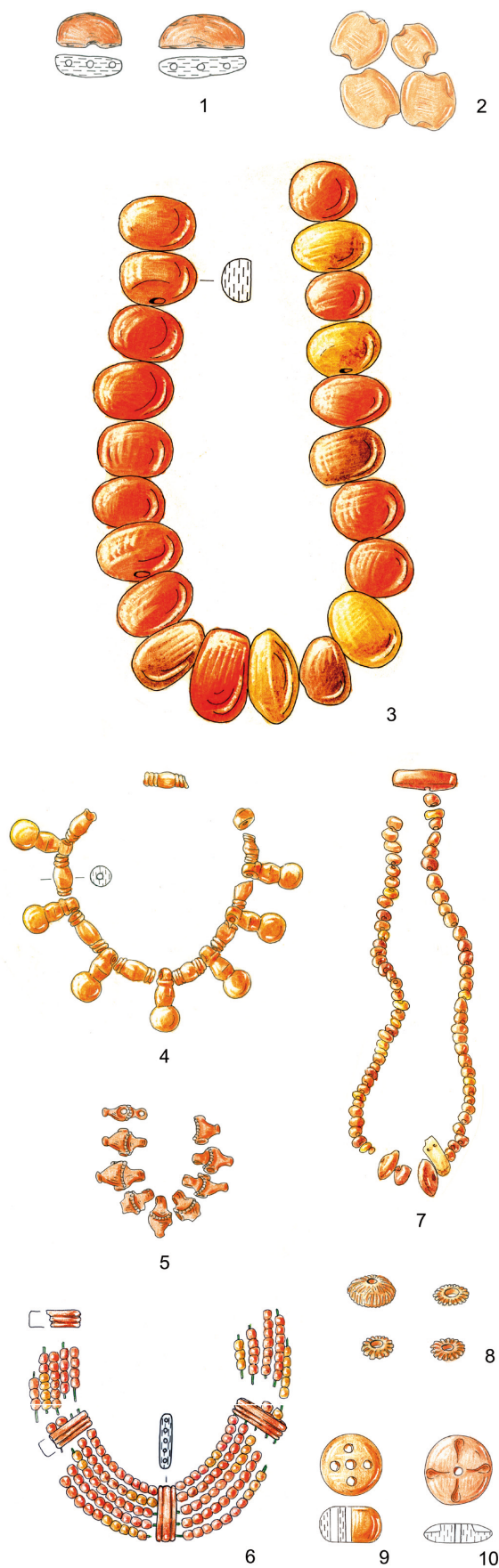

from Debeli vrh near Pregrad, which revealed beads of the Tiryns type.¹¹⁸¹ Apart from Teržan, an attempt at an evaluation of amber was also made by Wells, in his discussion on the Iron Age economy in the eastern Alps.¹¹⁸² He compared the presences of the material in the cemeteries from the Urnfield culture and the Hallstatt periods. As samples from Dolenjska, he used the Early Iron Age graves from Stična and Magdalenska gora, unearthed by the Duchess, and the Urnfield culture cemeteries at Dobova and Novo mesto. The result of the comparison is double; it showed, on the one hand, an absence of amber in the graves of the Late Bronze Age and, on the other hand, great differences in the quantity of amber between individual eastern Alpine sites in the Hallstatt period. A pride of place in that respect is held by Stična, followed by Magdalenska gora and Hallstatt and, with substantially smaller shares, Križna gora and Welzelach. In 1993, a comprehensive study on prehistoric amber in the central and western Balkans was published by Palavestra, who considered amber finds from several perspectives: cultural, historical, typological, chronological, analytical, providing a catalogue, but also presenting their distribution and place within the communication and exchange routes. In the appendix, he offered a typological evaluation of amber finds from Slovenia and included them in his synoptic typological and chronological maps.¹¹⁸³ His study took into account neither the subsequently published material from the tumuli at Stična¹¹⁸⁴ nor the finds from Magdalenska gora kept in the museums in Ljubljana and Vienna,¹¹⁸⁵ it only included the finds from the Peabody Museum.¹¹⁸⁶ Published subsequently to his study were also several catalogues of the material from the tumuli at Novo mesto.¹¹⁸⁷ Nevertheless, Palavestra's study represents the essential reference on the phenomenon not only for the eastern Adriatic and the Balkan areas, but also for the territory of modern Slovenia.

The grave groups from Magdalenska gora discussed so far clearly show amber to have been a very popular part of costume for both women and girls. The shares of amber

¹¹⁸¹ Hirschbäck-Merhar 1984, T. 9: 17; Teržan 1984b; *ead.* 1995a, 355 f, Abb. 24; *ead.* 1996a, 250 f; Čerče/Šinkovec 1995, 159 ff, T. 66: 66; Turk 1996a, 102, 108 ff.

¹¹⁸² Wells 1981, 111 f, Fig. XXVI, Tab. 6, 10.

¹¹⁸³ Palavestra 1993, 172 ff.

¹¹⁸⁴ Gabrovec *et al.* 2006.

¹¹⁸⁵ Tecco Hvala/Dular/Kocuvan 2004.

¹¹⁸⁶ Hencken 1978; Wells 1981.

¹¹⁸⁷ Knez 1993; Križ 1997; *id.* 2000; *id.* 2005; Križ/Turk 2003.

Sl. 105: Jantarni nakit z Magdalenske gore. M. = 1:2.

Fig. 105: Amber jewellery from Magdalenska gora. Scale = 1:2.
1, 5, – najdbe brez znanih grobnih celot v NHMW / finds without preserved grave group in the NHMW; 2 – Preloge, gr. 13/134; 3 – Preloge, gr. 2/h; 4 – Preloge, gr. 13/163; 6, 8, 9 – Preloge, gr. 13/117; 7 – Preloge, gr. 13/97; 10 – Voselca, gr. 2/17.

odstotkih med Wellsovim izračunom¹¹⁸⁸ in prikazanimi deleži na *sl. 104*. Grobov z jantarjem iz gomil IV, VII in X na Prelogah naj bi bilo po Wellsu 21,3 %, vendar pri izračunu ni upošteval vseh registriranih pokopov, zato je vrednost, ki jo je dobil, nekoliko višja. Sama sem se bolj kot na objavljene grobne sestave naslonila predvsem na Goldbergove opise, ki jih je povzel Hencken. Kakorkoli že gre v obeh poskusih vrednotenja zgolj za grobo oceno, ki ne upošteva količinskih vrednosti po enoti. Pravzaprav je težko priti do kvalitetnejših podatkov in primerljivih vrednosti, ker je zanesljivost sestavov in provenienca najdb, ki izvirajo iz izkopavanj vojvodinje Mecklenburške, vprašljiva. Verjetno bi do bolj realnih rezultatov prišli s tehtanjem jantarja iz gomil 2 in 13 na Prelogah, ki ga hrani dunajski muzej in pripada edinim zanesljivim grobnim celotam s tega najdišča, vendar tega nismo storili. To ni bilo storjeno niti za druga najdišča, z izjemo Wellsovega poskusa za gomilo IV iz Stične.¹¹⁸⁹

V zapuščini magdalenskogorske skupnosti so iz jantarja v glavnem ogrlice, sestavljene bodisi iz debelih ali pa bolj drobnih jagod (*sl. 105*), ki so jih pogosto dopolnjevale modre ali raznobarvne steklene jagode. Večina jantarnih jagod je kroglaste, kolobarjaste in diskaste oblike, z luknjico skozi ožji del, redkeje so ploščate in vzdolžno preluknjane jagode (*sl. 105: 2*),¹¹⁹⁰ rozetaste in amforičaste oblike (*sl. 105: 5, 8*) ter take, ki so večkrat preluknjane ali križno našlebljene (*sl. 105: 9, 10*),¹¹⁹¹ zasledimo pa tudi cilindrične profilirane in gobasto oblikovane jantarne jagode (*sl. 105: 4*).¹¹⁹² Posebnost predstavlja nakit, sestavljen iz jantarnih razdelilnih ploščic, skozi katere je bilo speljanih več nizov drobnih jantarnih jagodic (*sl. 105: 1, 6, 7*).¹¹⁹³ Razen tega se omenjajo ogrinjala z uvezenimi drobnimi jantarnimi in steklenimi perlicami,¹¹⁹⁴ ki so zagotovo bila razkošnega videza. Jantar se navezuje predvsem na skeletne grobove, v žganih grobovih le redko naletimo nanj.¹¹⁹⁵ V mlajšo železno dobo pa lahko datiramo grob 2/10 s Prelog, ki je vseboval jantarno ogrlico iz sodčastih jagod, stekleno zapestnico in poznolatenski fibuli.¹¹⁹⁶

Prvi pojav jantarja na območju jugovzhodnih Alp, kot rečeno, označujejo jagode tipa Tiryns, najdene v depozitu iz časa Ha A, ki je bil odkrit ob naravnem prehodu iz Kočevskega v smeri proti Jadranskemu morju. Ta tip jagod riše trgovske poti med zaledjem Jadrana in Grčijo.¹¹⁹⁷ V žarnogrobiščnih nekropolah v jugovzhodnih

¹¹⁸⁸ Wells 1981, Tab. 10.

¹¹⁸⁹ *Ibid.*, Text fig. 26.

¹¹⁹⁰ Tecco Hvala/Dular/Kocuvan 2004, T. 111E: 5.

¹¹⁹¹ *Ibid.*, T. 63: 16-19, 42-44, 106: 48-52, 130A: 14, 137C: 1.

¹¹⁹² *Ibid.*, sl. 39, T. 123: 4.

¹¹⁹³ *Ibid.*, T. 100: 8, 106: 40, 146: 18.

¹¹⁹⁴ *Preloge, gr. 2/a, 2/h, 13/97: ibid.*, 28 s, 31, 67, sl. 33.

¹¹⁹⁵ Jantar je bil najden v sledečih žganih grobovih: *Laščik, gr. 4/1, Preloge, gr. VI/2, 13/163; Voselca, gr. 6/1.*

¹¹⁹⁶ Tecco Hvala/Dular/Kocuvan 2004, T. 20A: 4.

¹¹⁹⁷ Teržan 1984b; Palavestra 1993, 251 s, karta razprostranjenosti s citirano literaturo; Bellitani 1997, 117 ss, Fig. 2.

jewellery in individual tumuli are fairly equal (*fig. 104*). There are differences between the shares calculated by Wells¹¹⁸⁸ and those presented here, on *fig. 104*. According to Wells, Tumuli IV, VII and X at Preloge included 21.3 % of graves with amber, whereby his calculation did not take into account all the documented burials, hence increasing the total share. In this publication, on the other hand, the calculation is based primarily on Goldberg's notes as published by Hencken. In spite of their differences, however, both calculations provide rough estimates that do not take into consideration the quantitative values per grave group. It is, in fact, difficult to obtain better data and comparable values, since the reliability of grave groups and the provenance of finds unearthed by the Duchess of Mecklenburg are questionable. We would probably arrive at a more realistic picture by weighing the amber from Tumuli 2 and 13 from Preloge, kept in the museum in Vienna, which represents the only reliable grave groups from the site. The only such attempt was performed by Wells for Tumulus IV from Stična.¹¹⁸⁹

The amber of the Magdalenska gora community mainly comes in the shape of necklaces, composed of variously sized beads (*fig. 105*), which were often combined with either blue or multicoloured beads of glass. Most of the amber beads are globular, annular or disc-shaped and perforated across the thinner side. Flat beads are rare, as are the beads perforated across the longer side (*fig. 105: 2*),¹¹⁹⁰ rosette and amphora-shaped beads (*fig. 105: 5, 8*) those with several perforations or with cross-shaped grooves (*fig. 105: 9, 10*),¹¹⁹¹ as well as cylindrical with mouldings and mushroom-shaped beads (*fig. 105: 4*).¹¹⁹² Exceptional are the jewellery finds include amber spacer plates that tied together several strings of small amber beads (*fig. 105: 1, 6, 7*).¹¹⁹³ There is also mention of clothing with small globular beads of amber and glass sewn onto them,¹¹⁹⁴ which certainly gave the dress a luxurious look. Amber was found primarily in inhumations and seldom in cremation graves.¹¹⁹⁵ It was also documented in one of the Late Iron Age graves, namely 2/10 from Preloge, which yielded an amber necklace composed of barrel-shaped beads, a glass bracelet and two Late La Tène fibulae.¹¹⁹⁶

As stated above, the first amber finds in the south-eastern Alps are the beads of Type Tiryns found in the Ha A hoard from Debeli vrh, a location along the natural

¹¹⁸⁸ Wells 1981, Tab. 10.

¹¹⁸⁹ *Ibid.*, text fig. 26.

¹¹⁹⁰ Tecco Hvala/Dular/Kocuvan 2004, T. 111E: 5.

¹¹⁹¹ *Ibid.*, T. 63: 16-19, 42-44, 106: 48-52, 130A: 14, 137C: 1.

¹¹⁹² *Ibid.*, Abb. 39, T. 123: 4.

¹¹⁹³ *Ibid.*, T. 100: 8, 106: 40, 146: 18.

¹¹⁹⁴ *Preloge, Gr. 2/a, 2/h, 13/97: ibid.*, 28 f, 31, 67, Abb. 33.

¹¹⁹⁵ Amber in cremation graves was found, for example, at *Laščik, Gr. 4/1, Preloge, Gr. VI/2, 13/163; Voselca, Gr. 6/1.*

¹¹⁹⁶ Tecco Hvala/Dular/Kocuvan 2004, T. 20A: 4.

Seznam kronološko določljivih grobnih celot k sl. 106
List of datable grave groups to fig. 106

Stopnja Podzemelj / Podzemelj phase:

Dobrnič, gr. 18/24: Parzinger 1988–1989, T. 35: 3.
Dragatuš-Veliki Nerajec, gr. 1/54: Spitzer 1973, T. 9: 3; Škvor Jernejčič 2011, T. 17: 6.
Loka pri Črnomlju, gr. 1/1, 1/2: Dular J. 1983, T. 1: 6, 3: 5.
Magdalenska gora-Preloge, gr. 13/134: Tecco Hvala/Dular/Kocuvan 2004, T. 111E: 4,5.

Stopnja Stična / Stična phase:

Boštanj-Mali Lukovec, gr. 3; Veliki Lukovec, gr. 2: Guštin 1974, T. 8: 3, 9: 12.
Brezje, gr. 1/12, 1/37, 1/43, 1/77, 2/2, 7/13, 7/37, 13/4, 13/18: Kromer 1959a, T. 3: 1, 7: 1, 9: 2, 15: 2,4, 16: 4, 17: 14, 27: 5, 38: 3, 51: 8.
Brusnice, gr. 5/2: Teržan 1974, T. 1: 11.
Dragatuš-Veliki Nerajec, gr. 11: Spitzer 1973, T. 2: 5; Škvor Jernejčič 2011, T. 7: 9.
Kaplja vas-Lopaneč, gr. 2/1: Dular J. 2003, T. 84: 2.
Libna-Špiler Tum. 2/gr. 5, Deržanič Tum. 5/gr. C: Guštin 1976, 44, T. 6: 10.
Loka pri Črnomlju, gr. 3/1: Dular J. 1983, T. 6: 5.
Magdalenska gora-Laščik, gr. 4/1, 1892/8, Preloge 2/h, 13/42, 13/161, 13/163: Tecco Hvala/Dular/Kocuvan 2004, 19, 22, T. 12A: 1, 78D: 2, 121B: 2, 123: 4.
Metlika-Hrib, gr. 1/18, 1/31: Grahek 2004, T. 3: 19, 6: 11.
Novo mesto-Znančeve njive, gr. 4/20, Grob s trinožnikom / Grave with tripod; Kapiteljska njiva, gr. 1/26, 4/2: Gabrovec 1968, T. 8: 1; Knez 1986, T. 39: 1; Knez 1993, T. 25: 7; Križ 2000, T. 2: 8.
Stična, gr. 48/27, 48/36, 48/43, 48/87, 48/127, 48/156; 5/4, 5/26, 5/29: Gabrovec et al. 2006, T. 21: 63–69, 22: 74–81, 27: 5, 29: 3–5, 51: 6,8, 74: 2, 89: 5, 109: 6–8, 126: 2, 127: 5.

Stopnja kačastih fibul / Serpentine Fibulae phase:

Blanca-Kladje, gr. 1/C: Dular J. 2003, T. 50: 6.
Boštanj-Mali Lukovec, gr. 4: Guštin 1974, T. 9: 2.
Brezje, gr. 2/1, 7/7, 7/32, 7/33, 7/39, 7/42, 13/13, 13/15, 13/37: Kromer 1959a, T. 19: 5, 30: 9, 31: 6, 33: 2,5, 34: 4, 37: 6, 48: 5–7, 49: 6.
Brusnice, gr. 6/2, 7/3, 17/1: Teržan 1974, T. 3: 7, 4: 2, 12: 3.
Dobrnič, gr. 13/5, 14/1: Parzinger 1988–1989, T. 18: 12, 19: 2;
Dragatuš-Veliki Nerajec, gr. 5: Spitzer 1973, T. 5: 4,5; Škvor Jernejčič 2011, T. 6: 8,10.
Libna-Špiler Tum. /gr. 3, Glogovšek Tum. 1/gr. 2, 12, 23, Planinc Tum./gr. 2, Volavšek Tum./gr. 6: Guštin 1974, 38 s, 24: 16,18,19, 28: 14, 50: 7, 61: 16, 62: 6.
Magdalenska gora-Preloge, gr. 2/19, 2/22, 2/27, 2/54, 2/81, 13/15, 13/77, 13/88, Voselca, gr. 2/12: Tecco Hvala/Dular/Kocuvan 2004, T. 28B: 1, 29C: 2, 30D: 5, 48B: 8, 62B: 1, 70A: 3, 91: 6, 95B: 2, 98B: 1, 134D: 4.
Novo mesto-Kapiteljska njiva, gr. A/14, 1/19, 1/23, 3/38: Knez 1986, T. 46: 6; id. 1993, T. 22: 6, 24: 1; Križ 1997, T. 61: 7.
Preska-Kosmatec, gr. 11, 18, 23: Guštin 1974, T. 13: 16, 16: 8, 18: 5.

Rihpovec, gr. 8: Dular J. 2003, T. 34: 3.
Rovišče, gr. 5-1884/6: Dular J. 2003, T. 75: 1.
Slančji vrh, gr. 1: Dular J. 2003, T. 86: 1.
Stična, gr. 48/17, 48/26, 48/40, 48/48, 48/67, 48/81, 48/86, 48/107, 48/112, 48/129, 48/131, 48/136, 48/138, 48/147, 48/151, 48/153, 48/162, 48/163, 48/164, 48/172, 48/179: Gabrovec et al. 2006, T. 10: 2, 15: 6, 28: 2, 31: 3, 35: 2, 47: 12, 49: 4, 64: 4,7, 66: 6, 75: 5, 76: 6, 78: 12, 79: 8, 85: 7, 87: 2, 88: 5, 93: 5, 94: 7,3, 99: 10, 103: 3,4.
Veliki Vinji vrh (Šmarjeta)-Čevnice pri Žalovičah, gr. VI(1896)/1: Dular A. 1991, T. 48: 10.
Volčje Njive, gr. 4, 9: Gabrovec 1956, T. 5: 1, 10: 3.

Stopnja certoških fibul / Certosa Fibulae phase:

Brezje, gr. 1/23, 1/48, 2/4, 7/2, 7/9, 13/6, 13/10, 13/12, 13/34: Kromer 1959a, T. 21: 9, 24: 5, 35: 8, 38: 9, 41: 13, 47: 6, 48: 8,14, 49: 3.
Brusnice, gr. 19/1: Teržan 1974, T. 13: 8.
Dobrnič, gr. 14/10, 14/14, 14/1, 18/7, 19/3: Parzinger 1988–1989, T. 23: 2, 24: 7, 25: 2, 33: 5, 38: 6.
Dolenjske Toplice, gr. 1/3, 2/12, 2/16, 2/19, 11/8, 11/12: Teržan 1976, T. 1: 8, 7: 8, 8: 11, 9: 6, 63: 11, 66: 11.
Libna-Špiler Tum. 2/gr. 2, Volčanšek Tum./gr. mm: Guštin 1974, T. 4: 4,11, 45: 6,7.
Magdalenska gora-Preloge, gr. 2/a, 2/24, 2/30, 2/53, 4/2, 13/2, 13/22, 13/36, 13/49, 13/57, 13/87, 13/97, 13/117, 13/152, 13/16; Voselca, gr. 2/16, 2/20, 2/21: Tecco Hvala/Dular/Kocuvan 2004, T. 8: 6, 30A: 3, 31C: 1, 48C: 1, 65B: 1, 66B: 2, 71B: 1, 76: 4, 80B: 2, 86B: 1, 95A: 7,8, 100: 8, 106: 40,47–54, 118: 7, 120B: 7, 137B: 7,8, 139B: 10,11.
Novo mesto-Znančeve njive, gr. 1/22, 2/8, 2/15, 2/19, 3/3; Kapiteljska njiva, gr. A/17, 3/11, 3/16, 3/19, 3/20, 3/54: Knez 1986, T. 5: 8, 18: 5, 20: 17, 21: 6, 24: 14,15, 46: 12; Križ 1997, T. 35: 5, 43: 10, 46: 4, 47: 8, 72: 2.
Rovišče, gr. 1-1883/9, 1-1883/22: Dular J. 2003, T. 65: 1–9, 70: 5, 72: 5.
Stična, gr. 48/1, 48/8, 48/98, 48/119-120, 48/121, 48/160, 48/169, 5/11: Gabrovec et al. 2006, T. 1: 8,13,16–18, 3: 7, 55: 16–21, 69: 8,23, 73: 54–58, 91: 1,2,6,7,9, 92: 15, 97: 3,5, 116: 6,8.
Roje pri Trebelnem, gr. l. 1899: Dular J. 2003, T. 29: 6.

Stopnja negovskih čelad / Negova Helmets phase:

Brezje, gr. 13/11: Kromer 1959a, T. 50: 13.
Dolenjske Toplice, gr. 2/9, 5/17, 5/18, 8/21, 10: 8, 13/6: Teržan 1976, T. 6: 2, 30: 4–6, 32: 5, 53: 13, 58: 8, 74: 5.
Magdalenska gora-Preloge, gr. 2/40, 13/43, 13/65, 13/96; Voselca, gr. 2/17: Tecco Hvala/Dular/Kocuvan 2004, T. 37B: 3, 78C: 4, 88C: 4, 99A: 1, 137C: 1,2.
Novo mesto-Znančeve njive, gr. 2/2, 3/1, 3/33, 4/3, 4/28; Kapiteljska njiva, gr. A/50, 1/29, 3/41, 5/21, 5/30, 5/35: Knez 1986, T. 13: 3, 24: 6, 28: 1,4–8, 36: 1,2, 42: 9, 49: 3; id. 1993, T. 27: 7; Križ 1997, T. 64: 6; id. 2000, T. 15: 4, 19: 3, 22: 15.

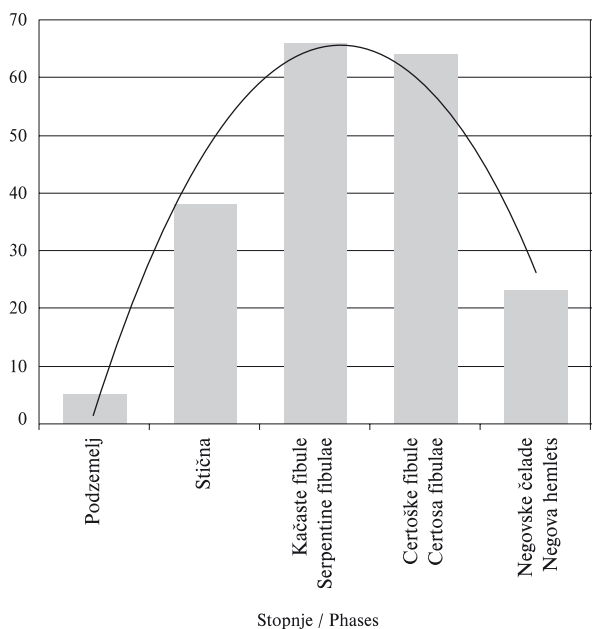

Sl. 106: Trend pojavljanja jantarja v starejši železni dobi na teritoriju dolenske skupnosti s seznamom kronološko določljivih grobnih celot (n = št. grobov).

Fig. 106: Trend line for the use of amber in the Early Iron Age on the territory of the Dolenjska community and list of datable grave groups (n = No. of graves).

Alpah jantarja ni, v grobovih ga zasledimo šele v železni dobi. Kronološko indikativne in zanesljive grobne celote s teritorija dolenske halštatske skupnosti (sl. 106 s seznamom) pa kažejo, da intenziteta pojavljanja jantarja ni bila konstantna. Zaznamo ga že v najzgodnejši fazi železne dobe, tj. v stopnji Podzemelj, večji razmah je doživel v stopnji Stična, kulminacijo je dosegel v stopnjah kačastih in certoških fibul, nato pa je v negovski stopnji drastično upadel. Ob tem naj poudarim, da ne gre za podrobnejšo analizo, temveč zgolj za splošno oceno.

Na Magdalenski gori se je jantar pojavil že v fazi formiranja te skupnosti, kamor lahko uvrstimo skeletni grob 13/134 na Prelogah s ploščatimi jantarnimi jagodami in bronastimi saltaleoni ter z enozankasto fibulo (sl. 77). V tistem času je zastopan še na nekaterih belokranjskih grobiščih (Loka pri Črnomlju in Dragatuš) ter v Dobrničju. Več oprav z jantarnim nakitom je izpričanih v stopnji Stična (sl. 106 s seznamom), največji delež pa je pripadal Stični in Brezju; ti dve središči sta obdržali primat tudi v stopnji kačastih fibul, pri čemer daleč pred drugimi izstopa prav Stična. V starohalštatskem nakitu in še v stopnji kačastih fibul so dozdevno prevladovali ogrlice iz debelejših jantarnih jagod, ki so mestoma dopolnjene s steklenimi enobarvnimi jagodami. Nosilo pa se je tudi okrasje iz nizov drobnih jantarnih jagod s pravokotnimi razdelivci (Stična, gr. 5/4; Vače, gr. 1878), ki ga Teržanova interpretira kot uhane.¹¹⁹⁸ Tak nakit se na Magdalenski

crossing from the Kočevje region towards the Adriatic. This bead type traces the trading routes between the hinterland of the Adriatic and Greece.¹¹⁹⁷ The Urnfield culture cemeteries of the south-eastern Alps revealed no amber; it only appeared in the graves of the Iron Age. Of those, the chronologically indicative and reliable grave groups from the territory of the Dolenjska community (fig. 106 with list) show that the use of amber varied in intensity. It appeared already in the earliest phase of the Iron Age, namely the Podzemelj phase, it witnessed a wider use in the Stična phase and a climax in the Serpentine and Certosa Fibulae phases. In the last, Negova phase, its use decreased drastically. It should be emphasized here that these are general observations, rather than the result of a detailed analysis.

Amber appeared at Magdalenska gora already in the community's formative phase. Ascribed to this phase is inhumation Grave 13/134 at Preloge, which revealed flat amber beads, bronze saltaleoni and a single-looped fibula (fig. 77). Dating to the same period are amber finds from several cemeteries in Bela krajina (Loka pri Črnomlju, Dragatuš) and at Dobrnič. Several grave groups with amber jewellery date to the Stična phase (fig. 106 with list), with greatest shares documented at Stična and Brezje. These two centres retained their primacy into the Serpentine Fibulae phase, whereby Stična revealed by far the greatest share. The taste in the Early Hallstatt period and even in the Serpentine Fibulae phase was apparently for necklaces composed of large amber beads, at places combined with glass beads of a single colour. Also worn were jewellery items composed of strings of small amber beads connected with rectangular spacer plates (Stična, Gr. 5/4; Vače, Gr. 1878), interpreted by Teržan as earrings.¹¹⁹⁸ Such jewellery is mentioned at Magdalenska gora among the goods of cremation Grave 6/1 from Voselca (fig. 24),¹¹⁹⁹ dated to the Stična phase, though it was also found in the graves of the Certosa phase (Preloge, Gr. 13/97, 13/117),¹²⁰⁰ when Magdalenska gora rose to the top among the sites of Dolenjska. Ranking behind Magdalenska gora in the quantity of amber are Novo mesto and Brezje, while Stična appears to have regressed in that period. Characteristic of the Certosa phase is a polychrome style with strings of small amber beads and multicoloured glass beads of various shapes and colours. Also found were individual examples of beads in the shape of a ram's head (Stična, Novo mesto), which may have been produced in an Italic workshop.¹²⁰¹ The Negova phase in Dolenjska witnessed a marked decrease

¹¹⁹⁷ Teržan 1984b; Palavestra 1993, 251 f with a distribution map and references; Bellitani 1997, 117 ff, Fig. 2.

¹¹⁹⁸ Teržan 1995b, 98 f, Abb. 33: 10,11, 37: 1.

¹¹⁹⁹ Tecco Hvala/Dular/Kocuvan 2004, 88.

¹²⁰⁰ *Ibid.*, T. 106: 40, 100: 8.

¹²⁰¹ Palavestra 1993, 259; Teßmann 2001, 91 ff, Abb. 63, 64; Egg 2010, 532.

¹¹⁹⁸ Teržan 1995b, 98 s, Abb. 33: 10,11, 37: 1.

gori omenja med pridatki žganega groba 6/1 z Voselce (*sl.* 24),¹¹⁹⁹ ki ga lahko datiramo v stopnjo Stična. Vendar ga zasledimo tudi v grobovih iz certoške stopnje (Preloge, gr. 13/97, 13/117),¹²⁰⁰ ko se je Magdalenska gora povzpela v sam vrh med dolensjimi najdišči. Za njo se po količini jantarja uvrščata Novo mesto in Brezje, medtem ko je Stična v tistem času dozdevno nazadovala. Za certoško stopnjo je značilen polihromni stil z nizi drobnejših jantarnih jagod in pisanih steklenih perl raznih barv in oblik, zasledimo pa tudi posamične primerke jantarnih jagod v obliki ovnove glavice (Stična, Novo mesto), ki so bili morebiti oblikovani v kaki italški delavnici.¹²⁰¹ V negovski stopnji je na Dolenjskem čutiti močan upad jantarja, hkrati pa je takrat sorazmerno največ jantarja premoglo Novo mesto (*sl.* 106 s seznamom).

Oglejmo si še zastopanost jantarja v sosednjih pokrajinah in s tem morebitne kašipote za "jantarno pot". Nekaj jantarja je zabeleženega na Gorenjskem,¹²⁰² kjer v Bitnjah v Bohinju srečamo sorodne jantarne razdelivce kot na Dolenjskem ali na Notranjskem (Križna Gora)¹²⁰³ v njih pa lahko vidimo odsev povezav med alpskim svetom in severnim Jadranom.¹²⁰⁴ Na Notranjskem se jantar pojavlja v časovnih stopnjah Notranjska IIB do IIIb (= Podzemelj 1 do Stična 2 na Dolenjskem), vendar v manjši količini, zasledimo pa ga v planih skeletnih grobovih.¹²⁰⁵ Tam najdemo še najbližje paralele za ogrlico iz magdalenskogorskega groba 13/134, sestavljeno iz ploščatih jantarnih jagod z vmesnimi bronastimi spiralnimi členi. Presenetljivo malo jantarja je bilo odkritega na teritoriju svetolucijske skupnosti. Med tisočimi grobovi je zastopan le v redkih primerih, ki sodijo pretežno v mlajše halštatsko obdobje.¹²⁰⁶ V Koritnici ob Bači, kjer je znano grobišče svetolucijskega tipa z žganimi pokopi, se omenjata dve jantarni jagodi v skeletnem grobu.¹²⁰⁷ Po količini jantarja je za dolensko skupnostjo zaostajala tudi koroška,¹²⁰⁸ še bolj očitno pa štajerska regija.¹²⁰⁹

¹¹⁹⁹ Tecco Hvala/Dular/Kocuvan 2004, 88.

¹²⁰⁰ Ibid., T. 106: 40, 100: 8.

¹²⁰¹ Palavestra 1993, 259; Teßmann 2001, 91 ss, Abb. 63, 64; Egg 2010, 532.

¹²⁰² *Brod, Bitnje, Lepence*: Gabrovec 1974b, T. 3: 1, 4: 9(1 jagoda), 22, 5: 8, 8: 2,5, 10: 3; *Kranj-Lajh*: Horvat 1983, T. 28: 1,10.

¹²⁰³ Urleb 1974, T. 26: 2.

¹²⁰⁴ Kossack 1959, 277, Abb. 18; Gabrovec 1974b, 303, *sl.* 7; Palavestra 1993, 203; Tomedi 2002, 202 s.

¹²⁰⁵ *Križna gora*, gr. 25, 72, 79, 112, 115, 124, 132: Urleb 1974, T. 6: 7,8, 15: 20, 17: 2, 4, 22: 10,11, 23: 3, 24: 14,15, 26: 2; Guštin 1973, 470, *sl.* 2, ter še *Čepna pri Knežaku*: Guštin 1979, T. 4: 6,7.

¹²⁰⁶ Npr. *Most na Soči*, gr. 376, 846, 1764, 2387: Marchesetti 1993, 109, 132, 173, 200, T. 25: 6-9 ter gr. 1484, 2414: Teržan/Trampuž 1973, T. 137: 26; Teržan/Lo Shiamo/Trampuž-Orel 1984, T. 137: 26, 257C: 4,13.

¹²⁰⁷ Gr. 52: Kos 1973, 859.

¹²⁰⁸ Npr. *Breg / Frög*, gr. 50/1,168/1, 272/1: Tomedi 2002, T. 17A: 7, 79: 11,12, 91E: 1.

¹²⁰⁹ Jantarna ogrlica se omenja v *Ormožu-Perčeva gomi-*

in the quantity of amber, with the relatively highest share documented at Novo mesto (*fig. 106 with list*).

Amber was, of course, also found in the neighbouring regions, the finds of which might allow us to retrace the route that amber travelled along. In Gorenjska,¹²⁰² amber finds came to light at Bitnje in Bohinj, in the shape of amber spacer plates similar to those in Dolenjska and Notranjska (Križna Gora)¹²⁰³ and may be seen as reflections of the connections between the Alpine and the northern Adriatic worlds.¹²⁰⁴ In Notranjska, amber finds date from the Notranjska IIB to IIIb phases (= Podzemelj 1 to Stična 2 in Dolenjska). They were found in smaller quantities and in flat cemeteries.¹²⁰⁵ This region also yielded the closest parallel for the necklace from Grave 13/134 from Magdalenska gora, composed of flat amber beads intermingled with bronze spiral elements. Surprisingly little amber was found on the territory of the Sveta Lucija community. Among the thousands of graves, only few contained amber and those mainly dating to the Late Hallstatt period.¹²⁰⁶ At Koritnica near Bača, a cemetery of the Sveta Lucija type with cremation burials, only two amber beads were documented inside an inhumation grave.¹²⁰⁷ Also lagging behind Dolenjska in the quantity of amber was Carinthia / Koroška,¹²⁰⁸ but even more so Styria / Štajerska.¹²⁰⁹

On the Apennine Peninsula, amber was known already in the Bronze Age,¹²¹⁰ the same in Istria, Lika and the central Balkans.¹²¹¹ The Balkans witnessed a marked interruption in the use of amber during Ha B, with the rare examples supposedly representing relicts from the earlier phase.¹²¹² It then began to be widely used in the Early Iron Age, particularly in the areas of the Iapodic, Liburnian and Glasinac cultural groups. Statistical analyses of the representation of amber in the cemeteries

¹²⁰² *Brod, Bitnje, Lepence*: Gabrovec 1974b, T. 3: 1, 4: 9(1 bead), 22, 5: 8, 8: 2,5, 10: 3; *Kranj-Lajh*: Horvat 1983, T. 28: 1,10.

¹²⁰³ Urleb 1974, T. 26: 2.

¹²⁰⁴ Kossack 1959, 277, Abb. 18; Gabrovec 1974b, 303, Abb. 7; Palavestra 1993, 203; Tomedi 2002, 202 f.

¹²⁰⁵ *Križna gora*, Gr. 25, 72, 79, 112, 115, 124, 132: Urleb 1974, T. 6: 7,8, 15: 20, 17: 2, 4, 22: 10,11, 23: 3, 24: 14,15, 26: 2; Guštin 1973, 470, Fig. 2, and *Čepna near Knežak*: Guštin 1979, T. 4: 6,7.

¹²⁰⁶ For example *Most na Soči*, Gr. 376, 846, 1764, 2387: Marchesetti 1993, 109, 132, 173, 200, T. 25: 6-9 and Gr. 1484, 2414: Teržan/Trampuž 1973, T. 137: 26; Teržan/Lo Shiamo/Trampuž-Orel 1984, T. 137: 26, 257C: 4,13.

¹²⁰⁷ Gr. 52: Kos 1973, 859.

¹²⁰⁸ For example *Frög*, Gr. 50/1,168/1, 272/1: Tomedi 2002, T. 17A: 7, 79: 11,12, 91E: 1.

¹²⁰⁹ One amber necklace was reportedly found in the *Ormož-Perc Tumulus*, one fibula with amber overlay at *Leibnitz*, while one amber bead was documented at *Lepa ravna below Poštela*: Teržan 1990a, 80, 133, 136, T. 62: 3.

¹²¹⁰ Negroni Catacchio 1984a; *ead.* 1984b; *ead.* 1999; Mastrocinque 1999; Bellintani 2004.

¹²¹¹ Palavestra 1993, 264; Hänsel *et al.* 2007, 110, Abb. 23.

¹²¹² Palavestra 1993, 275.

Na Apeninskem polotoku je bil jantar poznan že v bronasti dobi,¹²¹⁰ prav tako v Istri, Liki ter na centralnobalkanskem prostoru.¹²¹¹ Na Balkanu je v času Ha B občutna vrzel, redki primerki iz tistega časa pa domnevno predstavljajo prežitek iz starejše faze.¹²¹² Tudi tam se je razmahnil šele v starejši železni dobi, zlasti na območjih japodske, liburnijske in glasilaške kulturne skupine. Statistične analize zastopanosti jantarja v nekropolah v Liki (Smiljan, Kompolje, Prozor), Donji Dolini ob spodnji Savi ter na Glasincu v osrčju Balkana, ki jih je podal Palavestra, pa kažejo na podoben trend, kot je zaznaven v dolenjski skupnosti.¹²¹³ Na severozahodnem in osrednjem Balkanu je jantar prav tako dosegel vrhunec v drugi polovici 6. st. pr. n. št. in je po letu 500 pričel upadati.¹²¹⁴ Vzajemno povezanost balkanskega in dolenjskega prostora odražajo tudi karte razprostranjenosti posameznih oblik, kot so npr. ploščate jagode tipa 17 po Palavestri ali pravokotne razdelilne ploščice tipa 38, jagode v obliki rozete tipa 52 ali amforice tipa 49 ipd.,¹²¹⁵ ki sem jih izpostavila med magdalenskogorskimi najdbami. Količina jantarja in oblikovni spekter pričata, da je "jantarna pot" zagotovo potekala prek Dolenjske in Bele krajine¹²¹⁶ in da ga je halštatska skupnost na tem teritoriju sprejela v svojo nošo kot izraz prestiža ali pa verovanja v njegovo magijsko in zdravilno moč, o čemer govore antični pisci.¹²¹⁷

STEKLENE OGRVICE

Za razliko od jantarja so bile steklene jagode v jugovzhodnoalpskem svetu najdene že v grobovih iz časa kulture žarnih grobišč,¹²¹⁸ s čimer so omajana morebitna ugibanja, da se jantar v žganih grobovih pač ni ohranil, ker je bil nemara sežgan skupaj s preminulimi. V železni dobi je nakit, izdelan iz stekla, predstavljal nekakšen

la, fibula z jantarno oblogo v *Lipnici (Leibnitz)*, ena jagoda je dokumentirana na *Lepi ravni pod Poštelo*: Teržan 1990a, 80, 133, 136, T. 62: 3.

¹²¹⁰ Negroni Catacchio 1984a; ead. 1984b; ead. 1999; Mastrocinque 1999; Bellintani 2004.

¹²¹¹ Palavestra 1993, 264; Hänsel et al. 2007, 110, sl. 23.

¹²¹² Palavestra 1993, 275.

¹²¹³ *Ibid.*, 68 ss.

¹²¹⁴ *Ibid.*, 278 s.

¹²¹⁵ *Ibid.*, 196, 203, 209, 210.

¹²¹⁶ *Ibid.*, 281 ss; Palavestra/Krstić 2006, 34 ss, Fig. 15, 32, 34.

¹²¹⁷ Glej Palavestra 1993, 8 ss, z navedbo literature; Palavestra/Krstić 2006, 25 ss.

¹²¹⁸ *Dobova*: Stare F. 1975, T. 2: 5, 41: 3; *Ljubljana*: Stare F. 1954b, T. 14: 3; Puš 1971, T. 16: 13, 21: 6; id. 1982, T. 2: 3, 3: 5; *Novo mesto-Mestne njive, Kapiteljska njiva*: Križ 1995, Kat. št. 17, 37, 43, 51, 56, 59, 64-66, 68, 82, 113; *Tolmin*: Svoljšak/Pogačnik 2001, T. 5: 4, 20: 1, 21: 8, 16, 17, 22: 12, 29: 7, 33: 9, 36: 11-14, 37: 2, 12-14, 40: 4, 43: 4, 49: 2, 3, 55: 3, 56: 3, 57: 8, 59: 10, 64: 4, 65: 1, 66: 11-13, 67: 9, 68: 15, 69: 18, 76: 18-20, 77: 9, 83: 7, 8, 87: 9, 88: 15, 16, 89: 2, 9, 93: 4, 98: 15, 100: 16.

in Lika (Smiljan, Kompolje, Prozor), Donja Dolina, the lower Sava and at Glasinac in the heart of the Balkans, conducted by Palavestra, show a trend similar to the one observable in Dolenjska.¹²¹³ In the north-western and central Balkans, the use of amber also reached its peak in the second half of the sixth century BC and began to decline after 500 BC.¹²¹⁴ A connection between the Balkans and Dolenjska is underlined by the distribution maps for certain bead types, such as flat beads of Type 17 after Palavestra, rectangular spacer plates of Type 38, beads shaped either as rosettes of Type 52 or amphorae of Type 49 and others.¹²¹⁵ The quantity of amber as well as its formal range show that the Amber Route certainly passed through Dolenjska and Bela krajina¹²¹⁶ and that the communities in these territories accepted it in its costume either as an expression of prestige or of a belief in its magical and healing powers, as reported by ancient writers.¹²¹⁷

GLASS NECKLACES

As opposed to amber, glass beads in the south-eastern Alps were found already in the graves from the Urnfield culture period.¹²¹⁸ This negates the suppositions that amber in cremation graves simply was not preserved due to it being cremated together with the deceased. In the Iron Age, jewellery made of glass represented a sort of an emblem of the female costume of Dolenjska and, together with the polychrome style, contributed to the costume's colourfulness.¹²¹⁹

The research in glass jewellery shows that possibly one of the creative and distribution centres operated on the territory of the Dolenjska community.¹²²⁰ It would appear that, during the Early Hallstatt period, mostly single-colour (mainly dark blue) glass beads of globular form were being produced. In the Late Hallstatt period, on the other hand, the master glassmakers played with different colours and hues by applying glass threads in

¹²¹³ *Ibid.*, 68 ff.

¹²¹⁴ *Ibid.*, 278 f.

¹²¹⁵ *Ibid.*, 196, 203, 209, 210.

¹²¹⁶ *Ibid.*, 281 ff; Palavestra/Krstić 2006, 34 ff, Figs. 15, 32, 34.

¹²¹⁷ See Palavestra 1993, 8 ff, with further references; Palavestra/Krstić 2006, 25 ff.

¹²¹⁸ *Dobova*: Stare F. 1975, T. 2: 5, 41: 3; *Ljubljana*: Stare F. 1954b, T. 14: 3; Puš 1971, T. 16: 13, 21: 6; id. 1982, T. 2: 3, 3: 5; *Novo mesto-Mestne njive, Kapiteljska njiva*: Križ 1995, Cat. Nos. 17, 37, 43, 51, 56, 59, 64-66, 68, 82, 113; *Tolmin*: Svoljšak/Pogačnik 2001, T. 5: 4, 20: 1, 21: 8, 16, 17, 22: 12, 29: 7, 33: 9, 36: 11-14, 37: 2, 12-14, 40: 4, 43: 4, 49: 2, 3, 55: 3, 56: 3, 57: 8, 59: 10, 64: 4, 65: 1, 66: 11-13, 67: 9, 68: 15, 69: 18, 76: 18-20, 77: 9, 83: 7, 8, 87: 9, 88: 15, 16, 89: 2, 9, 93: 4, 98: 15, 100: 16.

¹²¹⁹ Križ/Turk 2003; Križ et al. 2009, 101 ff.

¹²²⁰ Haevernick 1959, Haevernick et al. 1983; Dobiak 1987; Kunter 1995; Egg 2010.

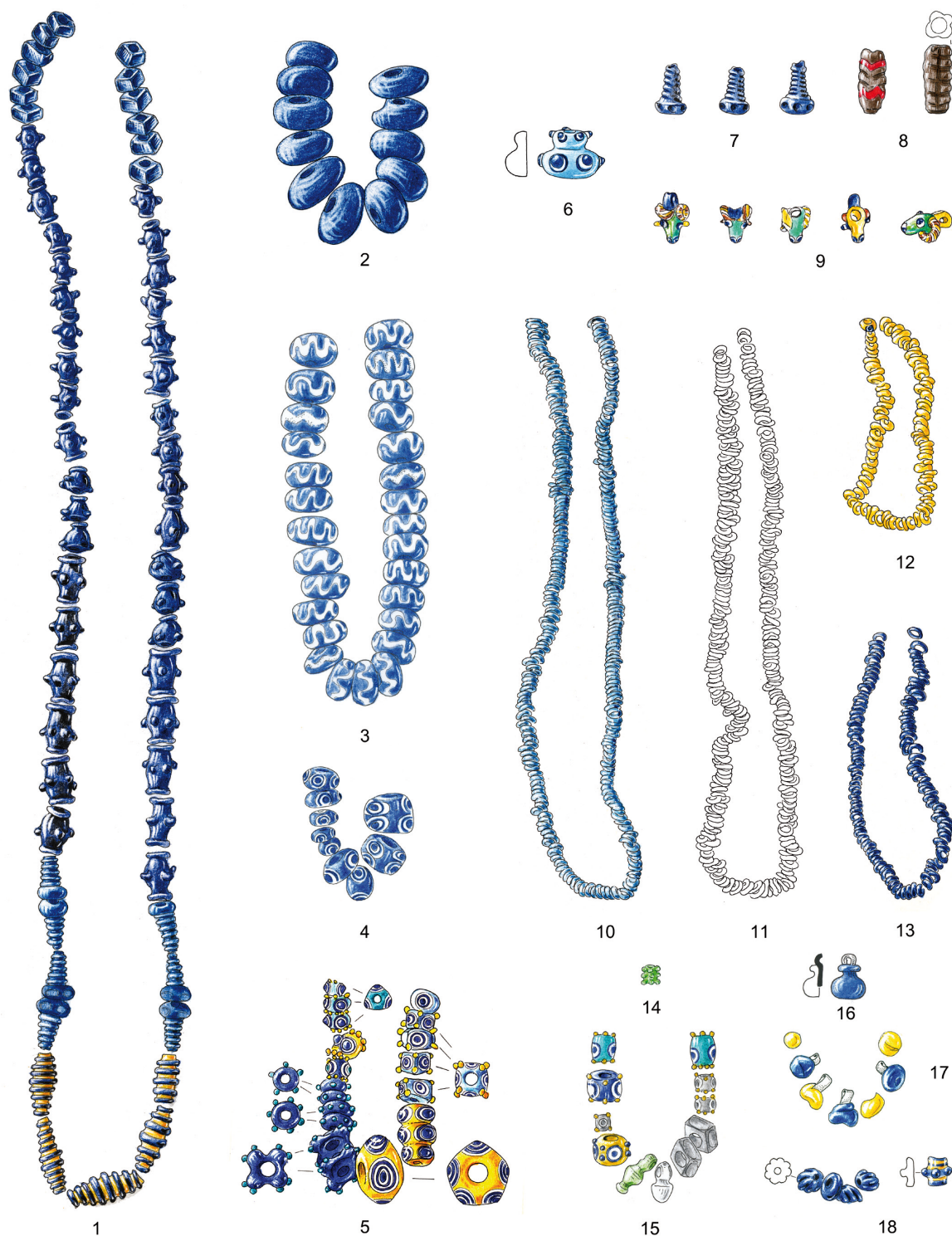

Sl. 107: Stakleno okrasje z Magdalenske gore. M. = 1:2.

Fig. 107: Glass jewellery from Magdalenska gora. Scale = 1:2.

1 – Preloge, gr. 2/c; 2 – Preloge, gr. 2/39; 3, 8 – Voselca, gr. 1/1;

4, 5, 14–16 – najdbe brez znanih grobnih celot v NHMW in NMS / finds without preserved grave group in the NHMW and NMS;
6 – Preloge, gr. 2/38; 7 – Preloge, gr. 2/1–2; 9–13 – Preloge, gr. 13/97; 17 – Preloge, gr. 13/163; 18 – Preloge, gr. 13/36.

“emblem” dolenske ženske noše in s polihromnim stilom prispeval k njeni barvitosti.¹²¹⁹

Raziskave steklenega okrasja razkrivajo, da je bilo na teritoriju dolenske skupnosti bržkone eno izmed ustvarjalnih in distribucijskih središč.¹²²⁰ Zdi se, da so v starejšem halštatskem obdobju izdelovali v glavnem enobarvne (povečini temnomodre) steklene jagode kroglaste oblike. V mlajšem halštatskem času pa so se steklarski mojstri poiğravali z raznolikostjo in barvnimi kontrasti z apliciranjem steklenih nitk v obliki valovnic, očesc, izrastkov in spiral (*sl. 107*). Njihove vrhunske večšine odražajo filigransko izdelane jagode v obliki vazic, rozet, vijakov in ovnovih glav; slednje primerja Egg z izdelki iz sredozemskih delavnic.¹²²¹ Ob tem velja izpostaviti še izgubljen steklen obesek z Magdalenske gore, ki upodablja človeški obraz; pripadal pa naj bi otroški opravi iz groba 2/11 na Prelogah, ki ga po drugih pridatkih lahko datiramo v stopnjo certoških fibul.¹²²² V študiji obraznih jagod ga omenja tudi Haevernickova. V njej podaja podrobnejši opis po Reineckejevi skici, ki pa je žal ni objavila niti ni zapisala, kje se ta skica hrani.¹²²³ Uvršča ga v skupino jagod z upodobljenim dekliskim ali ženskim obrazom s kodri na čelu; glavica naj bi bila zelenkaste barve z rumenim obrazkom, modrimi kodri na čelu, belimi ustnicami in očescema ter rumenim nosom. Ta obesek je zagotovo predstavljal import, ki je prav tako nastal v kaki od sredozemskih delavnic.¹²²⁴ Na območju jugovzhodnih Alp je znana le še ena podobna jagoda z Mosta na Soči, ki predstavlja moški obraz z nakodrano brado.¹²²⁵ Najdena je bila v grobu 2942 skupaj s triintriidesetimi steklenimi jagodami, kačasto fibulo in še eno z nazaj gledajočo konjsko glavico ter obeski.¹²²⁶ Tudi v tem okolju je to tuj element, saj sta stekleno okrasje in antropomorfna upodobitev v svetlucijem krogu izjemno redka.¹²²⁷ Jagode v obliki ženske, moške ali ovnovne glavice pa tudi vazic, vendar izdelane iz jantarja, so znane z japodskega prostora (Kompolje, Prozor) in iz najeminentnejših grobov 5. st. pr. n. št. na centralnobalkanskem območju (Novi Pazar, Atenica). Tovrstni predmeti so nedvomno zgovorne priče menjave dragotin na dolge razdalje.¹²²⁸

the shape of wavy lines or spirals, but also eyes and various protuberances (*fig. 107*). Their remarkable skill can be admired in the filigree beads in the shapes of vases, rosettes, screws and ram's heads; Egg compares the latter with the products of Carthaginian workshops.¹²²¹ In this connection, it is worth mentioning a pendant, shaped to represent a face, found at Magdalenska gora, but now lost; it reportedly formed part of a child's costume from Grave 2/11 at Preloge, dated to the Certosa phase on the basis of accompanying goods.¹²²² This pendant is mentioned in the study of face beads by Haevernick. She gives a more detailed description of the pendant on the basis of a sketch drawn by Reinecke. Unfortunately, she did not publish the sketch and neither did she state its place of keeping.¹²²³ She ranked the pendant among the beads depicting a girl's or woman's face with locks of hair on the forehead. She described the pendant as having a greenish head with a yellow face, blue locks, white lips and eyes, and a yellow nose. The pendant was certainly an import from a Mediterranean workshop.¹²²⁴ The south-eastern Alps yielded only one other similar bead, at Most na Soči, representing a male face with a curled beard.¹²²⁵ It was found in Grave 2942 together with thirty-three glass beads, a serpentine fibula and another fibula with a backward-facing horse's head and pendants.¹²²⁶ In the Sveta Lucija community as well, such an object is a foreign element, since both glass jewellery and anthropomorphic depictions are very rare finds.¹²²⁷ Beads shaped as female, male or ram's heads, but also as vases, though made of amber, are known from the Iapodic area (Kompolje, Prozor) and from the most eminent graves of the fifth century BC in the central Balkans (Novi Pazar, Atenica). These objects are a clear evidence of long-distance trade in precious goods.¹²²⁸

¹²¹⁹ Križ/Turk 2003; Križ et al. 2009, 101 ss.

¹²²⁰ Haevernick 1959, Haevernick et al. 1983; Dobiat 1987; Kunter 1995; Egg 2010.

¹²²¹ Egg 2010, 535 ss, Abb. 6–8.

¹²²² Tecco Hvala/Dular/Kocuvan 2004, 34.

¹²²³ Havernick 1981, 316, 351 (Kat. št. 663).

¹²²⁴ Haevernickova ga prišteva k skupini 22 skupaj z najdbami iz Kartagine, Cipra, Al Mine in En-Gedija.

¹²²⁵ Marchesetti 1993, 226, T. 29: 9; Havernick 1981, 310, 343, Kat. št. 468, Abb. 3.

¹²²⁶ Marchesetti 1993, 226, T. 29: 4,8.

¹²²⁷ Marchesetti 1993, 35, T. 8: 23,27-30, 8, 9; Teržan/Lo Schiavo/Trampuž-Orel 1984, T. 19A: 15.

¹²²⁸ Palavestra 1993, 209, 232, 233, 236, 257 s; Teßmann 2001, Abb. 63; Egg 2010.

¹²²¹ Egg 2010, 535 ff, Abb. 6–8.

¹²²² Tecco Hvala/Dular/Kocuvan 2004, 34.

¹²²³ Havernick 1981, 316, 351 (Kat. Nr. 663).

¹²²⁴ Haevernick added it to Group 22 together with finds from Carthagina, Cyprus, Al Mina and En-Gedi.

¹²²⁵ Marchesetti 1993, 226, T. 29: 9; Havernick 1981, 310, 343, Kat. Nr. 468, Abb. 3.

¹²²⁶ Marchesetti 1993, 226, T. 29: 4,8.

¹²²⁷ Marchesetti 1993, 35, T. 8: 23,27-30, 8, 9; Teržan/Lo Schiavo/Trampuž-Orel 1984, T. 19A: 15.

¹²²⁸ Palavestra 1993, 209, 232, 233, 236, 257 f; Teßmann 2001, Abb. 63; Egg 2010.

4.9 ZAPESTNICE, NAROKVICE IN NANOŽNICE

Tipično sestavino magdalenskogorskih oprav predstavlja obročasti nakit, ki hkrati razkriva precejšnjo oblikovno pestrost, raznovrstnost načinov izdelave ter materialov, iz katerih je izdelan. Iz položaja teh predmetov na okostju je razvidno (*sl. 34 in sl. 37*),¹²²⁹ da so se obroči nosili na zapestju, na nadlahtnicah in na gležnjih, zato jih lahko delimo na zapestnice, narokvice in nanožnice, ki so tudi različno velike. Zapestnice s premerom manjšim od 6,5 cm naj bi pripadale otrokom, tiste s premerom med 6,5 in 9,5 cm naj bi nosile odrasle osebe, medtem ko imajo nanožnice in narokvice premer večji od 9,5 cm. Te ocene so podprte s poročili izkopavalcev, ki govorijo o velikosti okostja s takim okrasjem.¹²³⁰

Glavne stilne tendence tovrstnega okrasja z območja Slovenije so znane. Za starejše halštatsko obdobje je značilen železen in bronast polno ulit obročast nakit z gladko površino in vrezanim okrasom, za mlajše halštatsko obdobje pa narebren slog in izdelki iz cevasto ukrivljene pločevine ter svinčeni primerki.¹²³¹

4.9.1 ŽELEZNE ZAPESTNICE

Železne zapestnice so na Magdalenski gori zabeležene v dveh žganih grobovih gomile VI na Prelogah (*sl. 108*), ki jo je kopala vojvodinja Mecklenburška.¹²³² Po Goldbergovih podatkih sta bila oba pokrita s kamnito ploščo; v grobu VI/24 sta na žganini ležali dve vozlasti fibuli tipa 5a, ene so se držali ostanki železnih zapestnic. Grob VI/27 pa je vseboval žaro s sežganimi kostmi in pridatki, med katerimi so bili poleg železne zapestnice še vozlasta fibula tipa 6a, majhen bronast obroček in drobna modra steklena jagoda.

Železen obročasti nakit je v jugovzhodnih Alpah znanilec železne dobe. Srečamo ga v planih žganih grobiščih v stopnjah Ljubljana IIb in IIIa,¹²³³ pojavlja pa se tudi v sklopu žganih gomilnih pokopov¹²³⁴ in v

¹²²⁹ Hencken 1978, Fig. 102, 244, 260, 311, 316, 325, 356; Tecco Hvala/Dular/Kocuvan 2004, sl. 31.

¹²³⁰ Glej opise grobov npr. *Laščik, gr. 1892/8, 1893/1, Preloge, gr. 2/a, 2/c, 2/o, 2/48, 2/55, 2/65, 2/66, 2/81, 13/37a, 13/61, 13/66, 13/77, 13/90, 13/114, 13/117, 13/152.*

¹²³¹ Gabrovec 1973, 343 ss, sl. 4; id. 1987, 41, 50, 59, 68, 74 s, sl. 1: 19,20, 3: 17-20, 4: 13,14, 5: 29,30, 6: 22-24; Hencken 1974; Teržan, 1974, sl. 4; ead. 1990a, karta 1; Parzinger 1988, T. 149.2; Parzinger/Nekvasil/Barth 1995, Abb. 12.2, 13.2,3, 14.4; Egg 1996, Abb. 126, 127; Grahek 2004, sl. 38, 39.

¹²³² Hencken 1978, 46, 47, Fig. 198, 201.

¹²³³ Taki grobišči, ki sta najbližji Magdalenski gori, sta bili odkriti na *Rojah pri Orlah* in v *Ljubljani*: Gabrovec 1973, 343 ss; Puš 1971, T. 3: 4, 6: 4, 13: 7,8, 21: 9, 29: 10, 38: 3,7, 39: 3, 40: 3, 41: 8d,e, 43: 6g, 45: 2; id. 1984, T. 1: 5.

¹²³⁴ Npr. *Brezje, gr. 82(=14/1)*: Kromer 1959a, T. 14: 2; Dular J. 2003, sl. 59: 13,14.

4.9 BRACELETS, ARMLETS AND ANKLETS

Ring jewellery represents a typical component of the Magdalenska gora costume. It reveals a considerable variety of form, production manner and material. The position of the ring jewellery on the skeleton shows that it was worn around the wrist, on the upper arm and around the ankle (*fig. 34 and fig. 37*);¹²²⁹ hence the group is divided into bracelets, armllets and anklets, which also differ in size. Bracelets smaller than 6.5cm in diameter were supposedly worn by children and those measuring between 6.5 and 9.5cm by adults. The rings measuring more than 9.5cm in diameter are interpreted as anklets or armllets. Such a criterion is supported by excavators' observations on the sizes of the associated skeletons, determinating them either as infants or as adult persons.¹²³⁰ The main stylistic characteristics of the ring jewellery from the territory of Slovenia are well known. To summarize, Early Hallstatt period is characterized by solid iron or bronze ring jewellery with a plain surface and incised decoration, while the Late Hallstatt period is marked by ribbing and tubular pieces made of sheet metal as well as lead rings.¹²³¹

4.9.1 IRON BRACELETS

At Magdalenska gora, iron bracelets were documented in two cremation graves in Tumulus VI at Preloge (*fig. 108*) excavated by the Duchess of Mecklenburg.¹²³² Both were covered by a stone slab according to Goldberg. Grave VI/24 revealed a pair of two-looped fibulae with a knobbed bow of Type 5a lying on the cremated remains, one with a fragment of iron bracelets adhered to it. Grave VI/27, on the other hand, contained an urn with cremated bones and burnt goods, namely an iron bracelet, a two-looped fibula with a knobbed bow of Type 6a, a small bronze ring and a small blue glass bead.

Iron ring jewellery heralds the Iron Age in the south-eastern Alps. It was documented in Urnfield cemeteries in the Ljubljana IIb and IIIa phases,¹²³³

¹²²⁹ Hencken 1978, Figs. 102, 244, 260, 311, 316, 325, 356; Tecco Hvala/Dular/Kocuvan 2004, Abb. 31.

¹²³⁰ See, for example, descriptions of the following graves: *Laščik, Gr. 1892/8, 1893/1, Preloge, Gr. 2/a, 2/c, 2/o, 2/48, 2/55, 2/65, 2/66, 2/81, 13/37a, 13/61, 13/66, 13/77, 13/90, 13/114, 13/117, 13/152.*

¹²³¹ Gabrovec 1973, 343 ff, Abb. 4; id. 1987, 41, 50, 59, 68, 74 f, figs. 1: 19,20, 3: 17-20, 4: 13,14, 5: 29,30, 6: 22-24; Hencken 1974; Teržan, 1974, Abb. 4; ead. 1990a, map 1; Parzinger 1988, T. 149.2; Parzinger/Nekvasil/Barth 1995, Abb. 12.2, 13.2,3, 14.4; Egg 1996, Abb. 126, 127; Grahek 2004, Figs. 38, 39.

¹²³² Hencken 1978, 46, 47, Figs. 198, 201.

¹²³³ Cf. Gabrovec 1973, 343 ff; Puš 1971, T. 3: 4, 6: 4, 13: 7,8, 21: 9, 29: 10, 38: 3,7, 39: 3, 40: 3, 41: 8d,e, 43: 6g, 45: 2; id. 1984, T. 1: 5.

VI/24



a

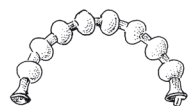

b

VI/27



c

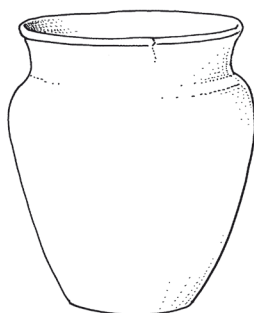

d

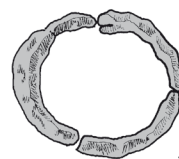

f



e



g

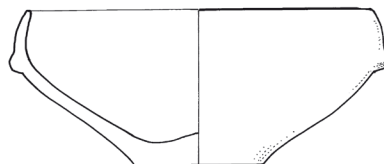

h

Sl. 108: Železne zapestnice v grobovih VI/24 in VI/27 z Magdalenske gore (po Hencknu 1978, Fig. 198, 201). M. = 1:4.
Fig. 108: Iron bracelets in Graves VI/24 and VI/27 from Magdalenska gora (after Hencken 1978, Figs. 198, 201). Scale = 1:4.

skeletnih grobovih v gomilah,¹²³⁵ ki so datirani v stopnjo Podzemelj 1.

while it also appeared in tumuli within cremation¹²³⁴ and inhumation graves¹²³⁵ from the Podzemelj 1 phase.

4.9.2 BRONASTE ZAPESTNICE, NAROKVICE IN NANOŽNICE

Večina magdalenskogorskega obročastega nakita je izdelana iz bronza. Po načinu izdelave ga lahko delimo v skupine polno ulitih primerkov, spiralno zvitihi žičnatih ali trakastih obročev ter takih, ki so izdelani iz cevasto ukrivljene bronaste pločevine. Razlike med njimi se kažejo še v oblikovnih shemah ter v stilu okraševanja.

4.9.2 BRONZE BRACELETS, ARMLETS AND ANKLETS

The majority of the ring jewellery from Magdalenska gora is made of bronze. In production manner, it can be divided into the following three groups: solid cast, spiral wire or spiral band bracelets, and those made of tubular sheet bronze. Differences are also observed in their form and decorative style.

POLNE GLADKE ZAPESTNICE IN NANOŽNICE

Tipološke značilnosti. Bronaste polne ulite zapestnice in nanožnice z gladko površino so bodisi sklenjene (sl. 109: 1, 5, 8) ali pa imajo razprte oz. presegajoče konce (sl. 109: 3, 6, 7, 9, 10); en obroč pa ima konca razkovan in preluknjana (sl. 109: 4). Med seboj se razlikujejo tudi po debelini in okrasu; eni obroči so brez okrasa (sl. 109: 1–4), drugi so okrašeni z drobnimi plitvimi vrezi. Ornamet je največkrat sestavljen iz snopov prečnih vrezov (sl. 109: 5–7), ki jih bolj redko dopolnjujejo še kakšni drugi okrasni motivi, kot npr. vrezi v obliki ležeče črke V, jelkove vejice ali ribje kosti (sl. 109: 8–10).

SOLID PLAIN BRACELETS AND ANKLETS

Typological characteristics. Bronze solid cast bracelets and anklets with a plain surface may either be annular (fig. 109: 1, 5, 8), penannular or with overlapping ends (fig. 109: 3, 6, 7, 9, 10); one ring even has flattened and perforated ends (fig. 109: 4). They further differ in thickness and decoration. Some examples are undecorated (fig. 109: 1–4) and others have incised decoration. The decoration mostly consists of stripes of transverse incisions (fig. 109: 5–7), which is rarely combined with

¹²³⁵ Npr. *Budinjak*, gr. 139/7: Škoberne 1999, 132, T. 17, 20: 2,3; *Pusti Gradac*, gr. 1/2, 5/8, 6/13: Dular J. 2003, T. 41: 2, 45: 2, 47: 2,3.

¹²³⁴ For example *Brezje*, Gr. 82(=14/1): Kromer 1959a, T. 14: 2; Dular J. 2003, Abb. 59: 13,14.

¹²³⁵ For example *Budinjak*, Gr. 139/7: Škoberne 1999, 132, T. 17, 20: 2,3; *Pusti Gradac*, Gr. 1/2, 5/8, 6/13: Dular J. 2003, T. 41: 2, 45: 2, 47: 2,3.

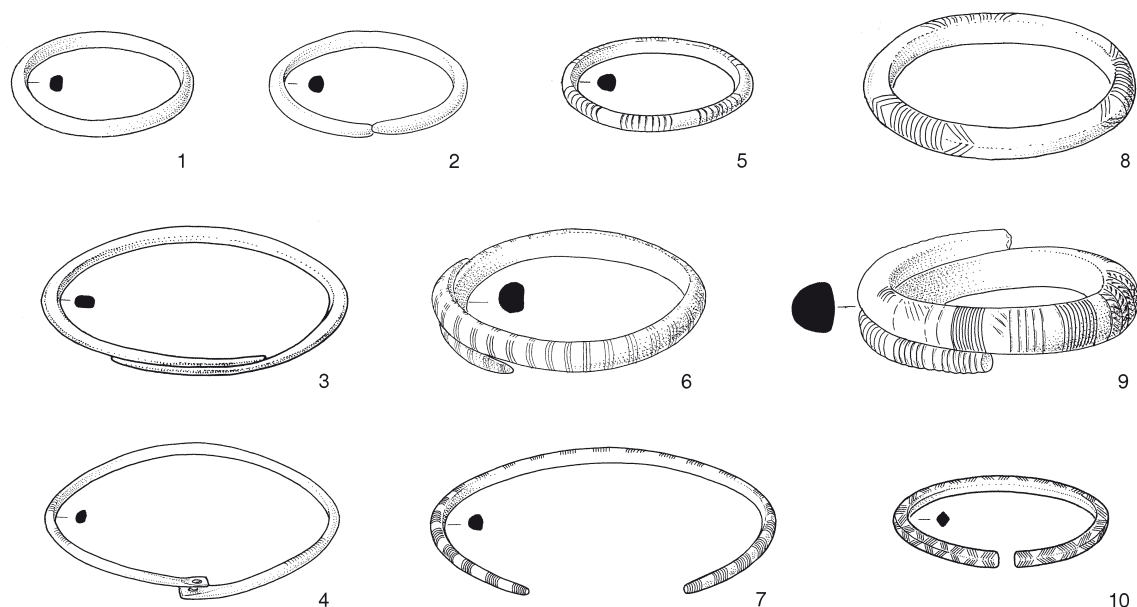

Sl. 109: Tipi bronastih polno ulitih gladkih zapestnic in nanožnic z Magdalenske gore. M. = 1:2.

Fig. 109: Types of solid and plain bronze bracelets and anklets from Magdalenska gora. Scale = 1:2.

1 – Voselca, gr. 2/6 (Ia); 2 – Preloge, gr. 13/61 (IIa); 3 – Laščik, gr. 1882/1 (IIa); 4 – Voselca, gr. 2/18; 5 – Laščik, gr. 1893/1 (IIb); 6 – Preloge, gr. 2/39 (IIb); 7 (IIb), 10 (♦) – Preloge, gr. 13/163; 8 – Preloge, gr. VI/20 (Ic); 9 – Laščik, gr. 1892/13 (IIc).

Lega in kontekst. Sklenjene neornamentirane obroče, ki jih označujem kot različico Ia (sl. 109: 1 in sl. 110), zasledimo na Magdalenski gori v dveh žganih grobovih skupaj z bronasto žičnato ovratnico.¹²³⁶ Po premeru sodeč gre za otroške zapestnice; k opravi iz groba VI/15 s Prelog so spadali še dvozankasta fibula tipa 6d, bronasta jagoda in vijček. Pojavljajo pa se tudi v skeletnih grobovih.¹²³⁷ V grobu 2/6 z Voselce je bila pokopana deklica s takim nakitom, v grobu 2/79 s Prelog pa ženska, medtem ko so v grobu 13/144 na Prelogah tako zapestnico našli pri komolcu okostja, ki je imelo ob glavi priloženo tulasto sekuro ter dve sulici, na prsih pa certoški samostrelni fibuli, ki sta izgubljeni. Nemara je šlo za moškega, čeprav naj bi pri glavi našli še nekaj steklenih jagod in par trakastih uhanov.

Bronast sklenjen zapestni obroček različice Ib, ki je okrašen s snopi vrezov (sl. 109: 5 in sl. 110), je inventariziran med pridatki skeletnega groba, ki ga je Pečnik odkril leta 1893 na Laščiku. O njem je zapisal, da je bil v njem pokopan otrok, ki naj bi imel svinčeno zapestnico (inventarizirana je bronasta), tri bronaste vozlaste ovratnice (dve sta izgubljeni) ter lepo fibulo, ki ni ohranjena.¹²³⁸

¹²³⁶ Preloge, gr. VI/15, VI/16: Hencken 1978, Fig. 189c, 190a.

¹²³⁷ Preloge, gr. 2/79, 13/144; Voselca, gr. 2/6: Tecco Hvala/Dular/Kocuvan 2004, T. 61D: 5, 115B: 6, 133: 15.

¹²³⁸ Laščik, gr. 1893/1: ibid., 23, T. 5B: 2.

other motifs, such as incised chevron, pine-sprig or herring-bone motifs (fig. 109: 8–10).

Position and context. Annular undecorated rings, marked as Variant Ia (fig. 109: 1 and fig. 110), were found at Magdalenska gora in two cremation graves together with a bronze wire torque.¹²³⁶ Their diameter indicates children's bracelets. Grave Group VI/15 from Preloge further included a two-looped fibula of Type 6d, a bronze bead and a spindle whorl. Variant Ia rings also appear in inhumation graves.¹²³⁷ Such jewellery was found with the girl buried in Grave 2/6 at Voselca, the woman in Grave 2/79 at Preloge, while in Grave 13/144 at Preloge such a bracelet lay at the elbow of a skeleton with a socketed axe and two spears beside the head, as well as two, now missing, Certosa crossbow fibulae on the chest. The latter skeleton could be determined as male, though report also lists several glass beads and a pair of band earrings found beside the head.

The bronze annular bracelet of Variant Ib, decorated with stripes of incisions (fig. 109: 5 and fig. 110), has been inventoried among the goods of an inhumation grave that Pečnik unearthed in 1893 at Laščik. Pečnik wrote of a child being buried in this grave, with

¹²³⁶ Preloge, Gr. VI/15, VI/16: Hencken 1978, Figs. 189c, 190a.

¹²³⁷ Preloge, Gr. 2/79, 13/144; Voselca, Gr. 2/6: Tecco Hvala/Dular/Kocuvan 2004, T. 61D: 5, 115B: 6, 133: 15.

Gom. / Gr. Tum. / Gr.	Pokop / Burial rite	Spol / Starost Sex / Age	Tip zapestnic / nanožnic Types of bracelets / anklets	Št. zapestnic / No. of bracelets	Št. nanožnic / No. of anklets	Fibule / Fibulae	Igle / Pins	Uhani / Earrings	Ovratnice / Torques	Steklene jagode / Glass beads	Jantar / Amber	Scepter / Sceptre	Diadem / Diadem	Pasne sponje / Belts	Sekire / Axes	Sulice / Spears	Lončenina / Pottery	Vijčki / Spindle whorls
P VI/16	C	I	Ia	2					1								1	
P VI/15	C	I		2		1			1								1	1
P 13/144	S	M?		1			2		2		1					1	2	
L 1893/1	S	I	Ib	1		1			3									
P VI/20	C	F	Ic	2													1	
P 2/79	S	F	Ia+IIa	2						x	x							
V 2/6	S	I	Ia+IIa+IIb	5+1*		4		2		br		1	x				3	1
P 13/65	S	I	IIa	1+1*		1				x	x						1	
P 13/61	S	I		2						x	x						1	
P 13/98	S	F		1					1		x							
P 13/50	S	?		2														2
P 13/53	S	M?		1			2							br			1	
L 1882/1	S	F		x			1											
P VII/7	C	F		x	x		1				2			Fe			x	3
P VII/46	C	F		x	x				x	x?								2
P 2/48	S	I		3	16		1		2+2									2
P VII/49	S	I		2			1			1								1
P X/24	S	I	2			2			1	x								
P 2/39	?	F	IIb	2		1+1?	1	x		x							1	4
V 2/16	?	I		2					x			x						
P VI/40	?	?		2														1
P VII/16	C	I		3				1	4		br							2
P 2/81	S	I		1+1*			2	1			x	x						
P 2/55	S	I	1			1			1	1							1	
L 1892/13	C	F	IIc	2		1											x	
P 13/42	S	F		2			1				x						1	
L 4/1	C	M+F		2			1				x							
P VI/2	C	I	IIa+IIb	2*	14	1					x						2	
L 1892/11	S	F		2	26+2				2?									
P 13/163	C	I?		6+6*	23		3					x					4	
P VII/40	S	F+I?		1+7*	24		9		4	6	x	x						5

Sl. 110: Struktura pridatkov v grobovih z bronastim polno ulitim gladkim obročastim nakitom na Magdalenski gori.

* = drugačen tip.

Fig. 110: Structure of goods in the graves with plain and solid bronze ring jewellery at Magdalenska gora. * = other type.

Par masivnih sklenjenih zapestnic različice **Ic**, ki sta ornamentirani z vrezanim motivom <<<IIIIII>>> (sl. 109: 8 in sl. 110), je edini te vrste z Magdalenske gore. Pripadal naj bi žganemu grobu VI/20 na Prelogah,¹²³⁹ glede na velikost pa bi ju lahko pripisali ženski noši. Grob je ležal v isti gomili in skoraj na enaki globini kot žgana grobova VI/15, VI/16 z zapestnicami različice Ia.

a lead bracelet (bronze one is inventoried), three bronze knobbed torques (two now lost) and a beautiful fibula, which has not been preserved.¹²³⁸

The two solid annular bracelets of Variant **Ic**, forming a pair and decorated with an incised <<<IIIIII>>> motif (fig. 109: 8 and fig. 110), are the only such examples from Magdalenska gora. They reportedly belonged to cremation

¹²³⁹ Hencken 1978, Fig. 194b.

¹²³⁸ Lašček, Gr. 1893/1: *ibid.*, 23, T. 5B: 2.

Drugo skupino gladkih polno ulitih obročev predstavljajo primerki z razprtimi ali presegajočimi konci. Tudi med njimi so opazne razlike v premerih, debelini, okrasu in kontekstih, v katerih se pojavljajo. Različica **IIa** združuje neornamentirane primerke (*sl. 109: 2, 3*),¹²⁴⁰ zasledimo pa jo tako v žganih kot v skeletnih grobovih (*sl. 110*). Povečini so spadale k otroškimi oz. dekliškim in ženskim opravam. Po Brattinovich besedah je imel otrok, pokopan v grobu 13/61 na Prelogah, taki zapestnici na desni roki; oni v grobu 13/65 iz iste gomile pa dve različni, na vsaki roki po eno. V grobu 2/48 s Prelog je bila po Pečnikovi oceni pokopana 15- ali 16-letna deklica, ki je imela tovrstne obroče na nogah, na vsaki po osem. Tudi primerke iz žganih grobov 13/163 in VI/2 s Prelog bi lahko opredelili za otroške nanožnice glede na to, da zraven nastopajo še manjše zapestnice. Primerki iz žganih grobov VII/7 in VII/46 s Prelog so bili razlomljeni, zato jih je težje količinsko in funkcionalno ovrednotiti. V grobu 1882/1 na Laščiku, na katerega so kmetje naleli pri kopanju peska, pa so take obroče menda našli na rokah okostja. Garnituro nanožnic in zapestnic je vseboval tudi skeletni grob VII/40 na Prelogah. V grobu 13/53 je bil en tak obroč najden na desnici okostja, ki je imelo še pravokotno pasno spono. Ker so tovrstne spono značilne predvsem za moško nošo, ni izključeno, da je zapestnico nosil moški. Časovni okvir pojavljanja te različice na Magdalenski gori najbolje zarisujejo fibule iz teh kontekstov. Zasledimo jo v kombinaciji z enozankasto fibulo,¹²⁴¹ s čolničastimi tipi¹²⁴² ali s trortasto fibulo vrste I po Ogrinovi¹²⁴³ in s fibulami z oblogo,¹²⁴⁴ kar kaže, da je bila v uporabi vse starejše halštatsko obdobje. Mestoma se pojavlja tudi v sestavih iz mlajšega halštatskega obdobja, kot npr. v otroškem grobu 13/65 s Prelog, kjer je bila taka zapestnica najdena skupaj z vzhodnoalpsko živalsko fibulo, ali pa v domnevno moškem grobu 13/53, v katerega so spadale še certoška fibula vrste XIII ter samostrelna fibula z naprej gledajočo konjsko glavico in bronasta pravokotna pasna spona. Ta dva grobova pričata, da so jih v mlajši certoški ali zgodnji negovski stopnji nosili otroci in moški.

Različica **IIb**, ki je okrašena s snopi vrezov (*sl. 109: 6, 7*),¹²⁴⁵ je zastopana v garniturah raznolikega obročastega okrasja (*sl. 110*), v paru pa nastopa v dekliških in ženskih opravah brez nanožnic, medtem ko je bil v grobu

¹²⁴⁰ Hencken 1978, Fig. 39d, 174e-g,i,j, 209b,d, 226k, 262j,o,r,s, 267c,d, 270c, 315a, 359v,w, 364u; Tecco Hvala/Dular/Kocuvan 2004, T. 3A: 2-9, 4: 1-24, 47A: 12-15, 61D: 4, 82A: 1,2, 82B: 3, 87B: 4,5, 88C: 6, 98B: 3, 111: 7, 124: 30-33, 133: 16, 150: 15.

¹²⁴¹ *Preloge, gr. 13/134.*

¹²⁴² *Laščik, gr. 1882/1; Preloge, gr. VII/7; Voselca, gr. 2/6.*

¹²⁴³ *Preloge, gr. VI/2, 2/48.*

¹²⁴⁴ *Preloge, gr. VII/40, 13/163.*

¹²⁴⁵ Hencken 1978, Fig. 62e, 174i, 214b; 235b, 262p; Tecco Hvala/Dular/Kocuvan 2004, T. 4: 25,26, 37A: 23,24, 49A, 4; 62B: 8, 124: 24-26,28,29,34; 133: 17, 137B: 5,6, 150: 2,3,9,10.

Grave VI/20 from Preloge,¹²³⁹ while their size indicates a female costume. The grave was found within the same tumulus and at more or less the same depth as cremation Graves VI/15 and VI/16 with bracelets of Variant Ia.

The second group of solid cast and plain rings is either penannular or with overlapping ends. These also show differences in diameter, thickness, decoration and context. Variant **IIa** comprises undecorated examples (*fig. 109: 2, 3*),¹²⁴⁰ which were found in both cremations and inhumations (*fig. 110*). They mostly belonged to women or children. According to Brattina, the child buried in Grave 13/61 at Preloge had two such bracelets on his/her right arm, while the child from Grave 13/65 from the same tumulus had two different ones, one on each arm. For the skeleton in Grave 2/48 at Preloge, Pečnik estimated that it was a 15- or 16-year-old girl. She was buried with such rings on her legs, eight on each. The examples from cremation Graves 13/163 and VI/2 from Preloge could also be identified as children's anklets in view of the fact that small bracelets were also found in them. The examples from cremation Graves VII/7 and VII/46 from Preloge were broken up, which makes it difficult to determine their number and function. As for Grave 1882/1 at Laščik, stumbled upon by a local farmer when digging for gravel, such rings were reportedly found on the arms of the skeleton. A set of anklets and bracelets was also found in inhumation Grave VII/40 at Preloge. Grave 13/53 yielded an example on the right arm of the skeleton that, in addition, had a rectangular belt clasp. The latter being typical of the male costume, it should not be excluded that the bracelet was actually worn by a man. The time frame for this variant at Magdalenska gora is best shown by the fibulae in the above-cited grave groups, namely a single-loop fibula,¹²⁴¹ boat fibulae,¹²⁴² a three-knobbed fibula of Type I after Ogrin¹²⁴³ and with the overlaid bow fibulae,¹²⁴⁴ which points to a use that lasted throughout the Early Hallstatt period. Apart from that, this ring jewellery was also found in several grave groups from the Late Hallstatt period. Such a bracelet was found, for example, in child's Grave 13/65 at Preloge together with an East Alpine animal-headed fibula, and in the presumably male Grave 13/53 with a Type XIII Certosa fibula, a crossbow fibula with a forward-facing horse's head and a bronze rectangular belt clasp. The latter two graves indicate that bracelets of this variant were worn

¹²³⁹ Hencken 1978, Fig. 194b.

¹²⁴⁰ Hencken 1978, Figs. 39d, 174e-g,i,j, 209b,d, 226k, 262j,o,r,s, 267c,d, 270c, 315a, 359v,w, 364u; Tecco Hvala/Dular/Kocuvan 2004, T. 3A: 2-9, 4: 1-24, 47A: 12-15, 61D: 4, 82A: 1,2, 82B: 3, 87B: 4,5, 88C: 6, 98B: 3, 111: 7, 124: 30-33, 133: 16, 150: 15.

¹²⁴¹ *Preloge, Gr. 13/134.*

¹²⁴² *Laščik, Gr. 1882/1; Preloge, Gr. VII/7; Voselca, Gr. 2/6.*

¹²⁴³ *Preloge, Gr. VI/2, 2/48.*

¹²⁴⁴ *Preloge, Gr. VII/40, 13/163.*

2/39 s Prelog par takih zapestnic menda nataknen na trakasto fibulo. Najdene so bile tudi v žganih grobovih (Preloge, gr. VI/40, VII/16). Nekoliko drugačno zapestnico, ki ima en konec suličasto oblikovan, zasledimo v otroškem grobu 2/81 s Prelog v kombinaciji z žičnato zapestnico ter kačasto in drobno ločno fibulo. Različici IIb je soroden tudi primerek iz otroškega groba 2/55 v isti gomili, ki je vseboval še gladko ovratnico in samostrelno fibulo z okrasno nogo (t. i. *Fußzierfibel*).

Kot različico IIc sem opredelila zelo debele zapestnice s stanjšanimi in profiliranimi zaključki, ki so okrašene s finim vrezanim okrasom (*sl. 109: 9 in sl. 110*).¹²⁴⁶ Znanе so iz dveh žarnih grobov z Laščika, kjer so bile nataknjene na fibulo; primerka v grobu 4/1 sta najdena v bronastem vedru tipa Kurd in obešena na dvozankasto fibulo tipa 6d, medtem ko sta bili zapestnici, najdeni v t. i. svetolucijskem pitosu v grobu 1892/13, speti z veliko čolničasto fibulo 3. skupine po Jerinovi. Pokojnica v grobu 13/42 s Prelog je imela na vsaki roki po eno tako zapestnico, k njeni opravi sta spadali še jantarna ogrlica in čolničasta fibula t. i. šmarješkega tipa. Dva masivna primerka, ki pa imata rahlo narebren okras, je nosila tudi najvidnejša predstavnica rodu iz gomile VII na Prelogah (VII/40). Vsi ti sestavi sodijo v čas stopnje Stična.

Edinstven primerek gladke polno ulite bronaste zapestnice, ki ima razkovana in preluknjana zaključka (*sl. 109: 4*),¹²⁴⁷ izvira iz groba 2/18 z Voselece, o katerem je Pečnik zapisal, da je vseboval dve zapestnici (ena je danes izgubljena), razen tega par certoških fibul vrste V, železno rombično pasno spono in obročke z izrastki. V sklopu te grobne celote je inventariziran še nož, ki ga Pečnik ne omenja. Ti dodatki kažejo bolj na moško kot na žensko nošo.

Svojevrsne so tudi bronaste zapestnice z rombičnim presekom in motivom v obliki rombov in jelkovih vejic (*sl. 109: 10*).¹²⁴⁸ En primerek je bil najden pri nogah pokojnice v grobu VII/40 s Prelog skupaj z drobnimi steklenimi jagodami, pripadal pa naj bi otroku, ki je bil domnevno pokopan ob njenih nogah. Dve taki zapestnici pa sta zabeleženi v žarnem grobu 13/163 s Prelog, ki je vseboval veliko raznovrstnega obročastega nakita. Gre za pokopa vodilnih predstavnic stopnje Stična 2, ki ju družijo tudi fibule s stekleno oblogo.

Razširjenost in časovni okvir. Bronaste sklenjene zapestnice različice Ia so znane z mnogih grobišč med Savo in Krko,¹²⁴⁹ kjer jih lahko srečamo že v planih

in the Late Certosa or Early Negova phases by men and children.

Variant IIb, decorated with stripes of incisions (*fig. 109: 6, 7*),¹²⁴⁵ appears in sets of varied ring jewellery (*fig. 110*), in pairs in the girl's or woman's costume without anklets, while Grave 2/39 from Preloge reportedly revealed a pair threaded onto a band bow fibula. Besides inhumation, they were also found in cremation graves (Preloge, Gr. VI/40, VII/16). A somewhat different bracelet, with one end shaped into a spearhead, was found in child's Grave 2/81 at Preloge in combination with a wire bracelet as well as a serpentine and a small bow fibula. Also similar to Variant IIb is the example found in child's Grave 2/55 from the same tumulus, which further revealed a plain torque and a crossbow fibula with a decorative foot.

Determined as Variant IIc are the thick bracelets with tapering and moulded ends, and decorated with thin incisions (*fig. 109: 9 and fig. 110*).¹²⁴⁶ Such examples came to light in two urn graves at Laščik, both threaded onto a fibula. In Grave 4/1, a pair of such bracelets was hanging from a two-looped fibula of Type 6d and found inside a bronze bucket of the Kurd type, while two bracelets in Grave 1892/13 were tied with a large boat fibula of Group 3 after Jerin and found inside a Sveta Lucija pithos. The female in Grave 13/42 from Preloge had such a bracelet on each of her arms, with her costume further consisting of an amber necklace and a boat fibula of the Šmarjeta type. The two solid examples with a lightly ribbed surface were worn by the most prominent female representative of Tumulus VII at Preloge (VII/40). All of the grave groups with Variant IIc date to the Stična phase.

The unique example of a solid cast bronze bracelet with a flattened and perforated ends (*fig. 109: 4*)¹²⁴⁷ was found in Grave 2/18 at Voseleca. As its goods, Pečnik lists two bracelets (one now lost), a pair of Type V Certosa fibulae, an iron rhombic belt clasp and knobbed rings. Not mentioned by Pečnik but inventoried within the grave group is a knife. The listed goods point to the male rather than a female costume.

Also unique are the bronze bracelets with a rhombic cross-section and decoration consisting of rhombic and pine-sprig motifs (*fig. 109: 10*).¹²⁴⁸ One was found at the feet of the female in Grave VII/40 at Preloge together with small glass beads; it supposedly belonged to a child buried beside her legs. Further two bracelets were documented in urn Grave 13/163 at Preloge that contained a multitude of ring jewellery. Both graves contained remains of the

¹²⁴⁶ Hencken 1978, Fig. 262g; Tecco Hvala/Dular/Kocuvan 2004, T. 1: 2, 5A: 2,3, 78D: 3,4, 150: 8.

¹²⁴⁷ Tecco Hvala/Dular/Kocuvan 2004, 86, T. 137 D: 3.

¹²⁴⁸ Hencken 1978, Fig. 262h; Tecco Hvala/Dular/Kocuvan 2004, T. 124: 23.

¹²⁴⁹ Brezje: Kromer 1959a, T. 50: 12; Dobrnič: Parzinger 1988–1989, T. 17: 3; Ljubljana: Puš 1971, T. 24: 4; id. 1982, T. 7: 8; Mokronog: neobjavljeno, NMS inv. št. P 1728–1731, 1734; Stična: Wells 1981, Fig. 109a; Vače: neobjavljeno,

¹²⁴⁵ Hencken 1978, Figs. 62e, 174i, 214b; 235b, 262p; Tecco Hvala/Dular/Kocuvan 2004, T. 4: 25,26, 37A: 23,24, 49A, 4; 62B: 8, 124: 24–26,28,29,34; 133: 17, 137B: 5,6, 150: 2,3,9,10.

¹²⁴⁶ Hencken 1978, Fig. 262g; Tecco Hvala/Dular/Kocuvan 2004, T. 1: 2, 5A: 2,3, 78D: 3,4, 150: 8.

¹²⁴⁷ Tecco Hvala/Dular/Kocuvan 2004, 86, T. 137 D: 3.

¹²⁴⁸ Hencken 1978, Fig. 262h; Tecco Hvala/Dular/Kocuvan 2004, T. 124: 23.

žarnih grobiščih v času stopnje Ljubljana I**b**,¹²⁵⁰ v stopnji Stična so izpričane v okviru žganih pokopov v gomilah¹²⁵¹ kakor tudi v skeletnih grobovih.¹²⁵² V tistem času so prav tako znane v svetolucijskem krogu (v stopnji Sv. Lucija I**c**)¹²⁵³ ter v notranjski železnodobni skupini (v stopnji Notranjska III).¹²⁵⁴ V mlajši certoški in zgodnji negovski stopnji pa jih na Dolenjskem mestoma zasledimo v moških grobovih.¹²⁵⁵ Gladko zapestnico nosi na levici tudi bronasta figurica vojščaka z negovsko čelado iz Idrije pri Bači.¹²⁵⁶

Različica **Ib**, okrašena s snopi vrezov, v dolenski noši ni prav pogosta,¹²⁵⁷ kronološko indikativna pa sta edinole konteksta z Magdalenske gore (Laščik, gr. 1893/1, Preloge, gr. VII/40), datirana v čas stopnje Stična 2. En primerek je znan še iz Notranjske¹²⁵⁸ in dva z Mosta na Soči, kjer nastopa v grobu 1412, ki sodi v stopnjo Sv. Lucija I**c**2.¹²⁵⁹

Zapestnice različice **Ic** se pojavljajo v prostoru, ki sega od obronkov Pohorja na vzhodu do Posočja na zahodu in do Gorjancev na jugu, kot je pokazala Teržanova, ki jih je označila za tip Poštela.¹²⁶⁰ Izpričane so v žganih grobovih iz časa Ljubljana I**b** in IIIa, kamor bi domnevno lahko umestili tudi magdalenskogorski grob VI/20 s Prelog s parom takih zapestnic in eno posodo.

V dolenski noši je bil bolj priljubljen nakit s presegajočimi stanjšanimi konci. Nesklenjeni konci so omogočali prilagajanje velikosti obroča, kar pri sklenjenih primerkih ni možno. Neornamentirane zapestnice in nanožnice s presegajočimi konci (različica **IIa**) so znane z mnogih najdišč na teritoriju dolenske skupnosti,¹²⁶¹ kjer ponekod nastopajo v garniturah,

NHMW inv. št. 3587, 6532, 8540; *Velike Malence*: Stare V. 1960–1961, T. 16: 1,2; *Veliki Vinji vrh (Šmarjeta)*: Stare V. 1973a, T. 28: 29, 55: 1-3; Dular A. 1991, T. 55: 16,17.

¹²⁵⁰ *Ljubljana, gr. 157*: Puš 1971, T. 24: 4, pril. 1; Gabrovec 1973, 343, sl. 4, 5.

¹²⁵¹ *Magdalenska gora-Preloge, gr. VI/15, VI/16*.

¹²⁵² *Magdalenska gora-Voselca, gr. 2/6; Dobrnič, gr. 12/7*: Parzinger 1988–1989, T. 17: 4,5.

¹²⁵³ *Most na Soči*: Teržan/Lo Schiavo/Trampuž-Orel 1984, T. 9: 6, 79: 7, 41: 2, 46: 1, 79: 7, 103: 7,8, 129: 14, 157: 12,13, 160: 7, 178: 3, 190: 10,11.

¹²⁵⁴ Guštin 1973, 472 s, sl. 2, T. 8: 4, 9: 4. *Križna gora*: Urleb 1974, T. 22: 13, 25: 2; *Šmihel*: Guštin 1979, T. 58: 10, 67: 1,4,5,18,19,23.

¹²⁵⁵ *Magdalenska gora-Preloge, gr. 13/144; Brezje, gr. 13/11*: Kromer 1959a, 69, T. 50: 12.

¹²⁵⁶ Guštin 1980, 255 s, sl. 1, T. 12.

¹²⁵⁷ *Vače*: Stare F. 1955a, T. 71: 8,10; *Veliki Vinji vrh (Šmarjeta)*: Dular A. 1991, T. 64: 18.

¹²⁵⁸ *Sv. Katarina pri Jelšanah*: Guštin 1979, T. 4: 10.

¹²⁵⁹ *Most na Soči*: Teržan/Lo Schiavo/Trampuž-Orel 1984, T. 130: 16, 189: 8.

¹²⁶⁰ Teržan 1990a, 64, 210, karta 1. *Ljubljana, gr. 214*: Puš 1971, 63 s, T. 40: 5; Gabrovec 1973, tabela 1.

¹²⁶¹ *Boštanj*: Guštin 1974b, T. 4: 16,17; *Brezje*: Kromer 1959a, T. 10: 3, 12: 1, 22: 3; *Brusnice*: Teržan 1974, T. 16: 11,12; *Čužnja vas*: Dular J. 2003, T. 21: 4-7, 10-13; *Dobrnič*:

leading female representatives of the Stična 2 phase, both of whom also wore fibulae with overlaid bow.

Distribution and time frame. Bronze annular bracelets of Variant **Ia** are known from numerous cemeteries between the Sava and the Krka.¹²⁴⁹ They were documented already in the Urnfield cemeteries of the Ljubljana I**b** phase,¹²⁵⁰ while in the Stična phase, they were buried in both cremation graves in tumuli,¹²⁵¹ as well as in inhumation graves.¹²⁵² In the same period, they were also known to the Sveta Lucija circle (Sv. Lucija I**c** phase)¹²⁵³ and to the Notranjska Iron Age community (Notranjska III phase).¹²⁵⁴ In the Late Certosa and Early Negova phases, they appeared in several male graves of Dolenjska.¹²⁵⁵ Moreover, a plain bracelet can also be observed on the left arm of the bronze statuette with a Negova helmet from Idrije pri Bači.¹²⁵⁶

Variant **Ib**, decorated with stripes of incisions, was not a common item within the Dolenjska costume.¹²⁵⁷ It dates to the Stična 2 phase, as indicated by the chronologically indicative grave groups from Magdalenska gora (Laščik, Gr. 1893/1, Preloge, Gr. VII/40). Contemporary examples from Most na Soči, from Grave 1412, date to the Sv. Lucija I**c**2 phase.¹²⁵⁸ One example was also documented in Notranjska.¹²⁵⁹

Variant **Ic** bracelets appear from the outskirts of the Pohorje Hills in the east, to the Soča Valley in the west and the Gorjanci Hills in the south, as was observed by Teržan, who also marked the variant as Type Poštela.¹²⁶⁰ They were found in cremation graves from the Ljubljana

¹²⁴⁹ *Brezje*: Kromer 1959a, T. 50: 12; *Dobrnič*: Parzinger 1988–1989, T. 17: 3; *Ljubljana*: Puš 1971, T. 24: 4; *id.* 1982, T. 7: 8; *Mokronog*: unpublished, NMS Inv. Nos. P 1728–1731, 1734; *Stična*: Wells 1981, Fig. 109a; *Vače*: unpublished, NHMW Inv. Nos. 3587, 6532, 8540; *Velike Malence*: Stare V. 1960–1961, T. 16: 1,2; *Veliki Vinji vrh (Šmarjeta)*: Stare V. 1973a, T. 28: 29, 55: 1-3; Dular A. 1991, T. 55: 16,17.

¹²⁵⁰ *Ljubljana, Gr. 157*: Puš 1971, T. 24: 4, Beil. 1; Gabrovec 1973, 343, Abb. 4, 5.

¹²⁵¹ *Magdalenska gora-Preloge, Gr. VI/15, VI/16*.

¹²⁵² *Magdalenska gora-Voselca, Gr. 2/6; Dobrnič, Gr. 12/7*: Parzinger 1988–1989, T. 17: 4,5.

¹²⁵³ *Most na Soči*: Teržan/Lo Schiavo/Trampuž-Orel 1984, T. 9: 6, 79: 7, 41: 2, 46: 1, 79: 7, 103: 7,8, 129: 14, 157: 12,13, 160: 7, 178: 3, 190: 10,11.

¹²⁵⁴ Guštin 1973, 472 f, Fig. 2, T. 8: 4, 9: 4. *Križna gora*: Urleb 1974, T. 22: 13, 25: 2; *Šmihel*: Guštin 1979, T. 58: 10, 67: 1,4,5,18,19,23.

¹²⁵⁵ *Magdalenska gora-Preloge, Gr. 13/144; Brezje, Gr. 13/11*: Kromer 1959a, 69, T. 50: 12.

¹²⁵⁶ Guštin 1980, 255 f, Abb. 1, T. 12.

¹²⁵⁷ *Vače*: Stare F. 1955a, T. 71: 8,10; *Veliki Vinji vrh (Šmarjeta)*: Dular A. 1991, T. 64: 18.

¹²⁵⁸ *Most na Soči*: Teržan/Lo Schiavo/Trampuž-Orel 1984, T. 130: 16, 189: 8.

¹²⁵⁹ *Sv. Katarina near Jelšane*: Guštin 1979, T. 4: 10.

¹²⁶⁰ Teržan 1990a, 64, 210, map 1. *Ljubljana, Gr. 214*: Puš 1971, 63 f, T. 40: 5; Gabrovec 1973, Tabelle 1.

sestavljanih iz več primerkov. Najstarejši primer take noše je znan iz Pustega Gradca v Beli krajini, kjer naj bi po Pečnikovem poročilu v grobu 6/13 našli okostje, ki je imelo na desni nogi 6, na levi pa 7 bronastih nanožnic (žal niso ohranjene), na rokah je imelo železni zapestnici, na prsni železno fibulo in okoli vratu železno ovratnico, kar kaže na pokop v času stopnje Podzemelj 1.¹²⁶² V planem žarnem grobišču v Ljubljani je zabeležen komplet 10 narokvic ali nanožnic v grobu 267 skupaj s tordirano ovratnico in veliko čolničasto fibulo 3. skupine po Jerinovi, kar govori za čas stopnje Stična 2.¹²⁶³ V žari iz tega groba so bili po rezultatih antropološke analize shranjeni posmrtni ostanki dveh odraslih oseb – ženske, stare okoli 30 let in visoke približno 155–160 cm, ter še ene 30- do 40-letne osebe, katere spol ni določljiv.¹²⁶⁴ Na Magdalenski gori in v Stični zasledimo take garniture v nekaterih žganih,¹²⁶⁵ pa tudi v skeletnih grobovih v gomilah.¹²⁶⁶ Antropološka analiza kostnih ostankov iz stiških grobov je pokazala, da je bila v grobu 5/4 pokopana odrasla ženska (na nogah je imela skupaj 32 nanožnic), v grobu 5/13, iz katerega je ohranjen le komplet 16 nanožnic za eno nogo, pa ženska zrelih let, medtem ko naj bi bila pokojnica iz groba 48/27, ki je imela 11 raznovrstnih nanožnic, stara med 18 in 25 let.¹²⁶⁷ Na Vačah nastopa garnitura šestih narebrenih zapestnic in treh gladkih nanožnic s presegajočimi zaključki v grobu 46, ki je vseboval še kačasti fibuli s sedlastim lokom (na eno je bil pritrjen obesek z antropomorfnimi figurami in sončno ladjo).¹²⁶⁸ Podoben komplet naj bi našli tudi v gomili na Delih pri Kladju nad Blanco v žganem grobu

Stare V. 1973b, T. 14: 11-14; Parzinger 1988–1989, T. 12: 3, 19: 1, 44: 8; *Libna*: Guštin 1976, T. 11: 12,13, 15: 4, 22: 4, 69: 1-4, 70: 1,2,8, 71: 15-17,19; 78: 3; *Mokronog*: neobjavljeno, NMS inv. št. P 6242, 6243, 6288, 6289; *Novo mesto*: Gabrovec 1968, T. 6: 5; *Podzemelj*: Dular J. 1978, T. 11: 9-13; *Rovišče*: id. 2003, T. 77: 7; *Stična*: Wells 1981, Fig. 35a, 75b; Gabrovec et al. 2006, T. 20: 57,58, 28: 38/2, 110: 23,27, 118: 3, 146: 11, 155: 32-42, 156: 43-47, 168: 3, T. 175: 89-114, 187: 54, 186: 39, 188: 8-19, 189: 8; *Vače*: Stare F. 1955a, T. 67: 3, 74: 1,3,5-10, 76: 2 in neobjavljeni primerki, NHMW inv. št. 7967, 8104, 8168, 8494, 8548, 8549, 14185, 14186; *Velike Malence*: Stare V. 1960–1961, T. 14: 1,2; Dular J. 2003, T. 59: 15; *Veliki Vinji vrh* (*Šmarjeta*): Stare V. 1973a, T. 28: 8,17-20, 22-25, 27,28, 29: 16, 30: 14, 31: 1,7,13,14, 55: 4, 6,21, 60: 20; Dular A. 1991, T. 6: 13, 8: 8,9, 10: 7, 17: 7, 21: 5,6, 28: 1, 34: 5, 47: 11,12, 50: 2, 64: 9-11,14, 72: 12,21, 73: 31,33; *Vinkov vrh*: Stare V. 1964–1965, T. 13: 1; *Zagorje*: Gabrovec 1966b, T. 6: 4.

¹²⁶² Dular J. 2003, 215, T. 49: 2-7.

¹²⁶³ Puš 1982, T. 3: 6-15, 11: 7,9,10.

¹²⁶⁴ Tomazo-Ravnik 1982.

¹²⁶⁵ *Magdalenska gora-Preloge, gr. 13/163; Stična-Japova gomila*: Gabrovec et al. 2006, 182 ss, T. 155, 156.

¹²⁶⁶ *Magdalenska gora, gr. 1882/1, 1892/11, 2/48, VI/2, VII/7, VII/40, VII/46; Stična, gr. 5/4, 5/13, 48/27, 48/87*: Gabrovec et al. 2006, T. 16–23, 20: 48-53, 109–111, 118, 175; *Libna-Deržaničeva gom. 1/gr. 1*: Guštin 1976, T. 11, 12: 4.

¹²⁶⁷ Gabrovec et al. 2006, 32 s, 133, 141.

¹²⁶⁸ Teržan 2003, T. 6.

IIb and IIIa phases. The same time frame could be ascribed to Grave VI/20 from Preloge that yielded a pair of such bracelets together with a clay vessel.

More popular pieces of the Dolenjska costume than the jewellery types discussed above were those with overlapping and tapering ends. As opposed to annular examples, these allowed the size of the ring to be adjusted to the wearer. Undecorated bracelets and anklets with overlapping ends (Variant IIa) are known from numerous sites on the territory of the Dolenjska community,¹²⁶¹ where they sometimes appear in sets of several examples. The earliest example of such a costume is known from Pusti Gradec in Bela krajina. According to Pečnik, Grave 6/13 from the site revealed a skeleton with 6 bronze anklets on the right and 7 on the left leg (unpreserved), one iron bracelet on each of the arms, an iron fibula on the chest and an iron torque around the neck, which point to a burial of the Podzemelj 1 phase.¹²⁶² Recorded in the flat cremation cemetery in Ljubljana was a set of 10 armlets or anklets in Grave 267 together with a twisted torque and a large boat fibula of Group 3 after Jerin, which indicates a Stična 2 phase burial.¹²⁶³ The anthropological analysis revealed that the urn in this grave contained the remains of two adult individuals, namely a female, roughly 30 years old and 155–160cm tall, and a 30–40-year-old individual of undeterminable sex.¹²⁶⁴ At Magdalenska gora and Stična, such sets were unearthed in several cremations,¹²⁶⁵ but also in inhumation burials into tumuli.¹²⁶⁶ The anthro-

¹²⁶¹ *Boštanj*: Guštin 1974b, T. 4: 16,17; *Brezje*: Kromer 1959a, T. 10: 3, 12: 1, 22: 3; *Brusnice*: Teržan 1974, T. 16: 11,12; *Čužnja vas*: Dular J. 2003, T. 21: 4-7, 10-13; *Dobrnjič*: Stare V. 1973b, T. 14: 11-14; Parzinger 1988–1989, T. 12: 3, 19: 1, 44: 8; *Libna*: Guštin 1976, T. 11: 12,13, 15: 4, 22: 4, 69: 1-4, 70: 1,2,8, 71: 15-17,19; 78: 3; *Mokronog*: unpublished, NMS Inv. Nos. P 6242, 6243, 6288, 6289; *Novo mesto*: Gabrovec 1968, T. 6: 5; *Podzemelj*: Dular J. 1978, T. 11: 9-13; *Rovišče*: id. 2003, T. 77: 7; *Stična*: Wells 1981, Figs. 35a, 75b; Gabrovec et al. 2006, T. 20: 57,58, 28: 38/2, 110: 23,27, 118: 3, 146: 11, 155: 32-42, 156: 43-47, 168: 3, T. 175: 89-114, 187: 54, 186: 39, 188: 8-19, 189: 8; *Vače*: Stare F. 1955a, T. 67: 3, 74: 1,3,5-10, 76: 2 and unpublished examples, NHMW Inv. Nos. 7967, 8104, 8168, 8494, 8548, 8549, 14185, 14186; *Velike Malence*: Stare V. 1960–1961, T. 14: 1,2; Dular J. 2003, T. 59: 15; *Veliki Vinji vrh* (*Šmarjeta*): Stare V. 1973a, T. 28: 8,17-20, 22-25, 27,28, 29: 16, 30: 14, 31: 1,7,13,14, 55: 4, 6,21, 60: 20; Dular A. 1991, T. 6: 13, 8: 8,9, 10: 7, 17: 7, 21: 5,6, 28: 1, 34: 5, 47: 11,12, 50: 2, 64: 9-11,14, 72: 12,21, 73: 31,33; *Vinkov vrh*: Stare V. 1964–1965, T. 13: 1; *Zagorje*: Gabrovec 1966b, T. 6: 4.

¹²⁶² Dular J. 2003, 215, T. 49: 2-7.

¹²⁶³ Puš 1982, T. 3: 6-15, 11: 7,9,10.

¹²⁶⁴ Tomazo-Ravnik 1982.

¹²⁶⁵ *Magdalenska gora-Preloge, Gr. 13/163; Stična-Japova Tum.*: Gabrovec et al. 2006, 182 ff, T. 155, 156.

¹²⁶⁶ *Magdalenska gora, Gr. 1882/1, 1892/11, 2/48, VI/2, VII/7, VII/40, VII/46; Stična, Gr. 5/4, 5/13, 48/27, 48/87*: Gabrovec et al. 2006, T. 16–23, 20: 48-53, 109–111, 118, 175; *Libna-Deržanič Tum. 1/Gr. 1*: Guštin 1976, T. 11, 12: 4.

skupaj s kačasto fibulo s sedlastim lokom ter jantarno ogrlico.¹²⁶⁹ Slednja dva pokopa predstavljata najmlajši opravi z garniturami obročastega nakita. Število kosov, ki so sestavljali komplet, pa je morebiti povezano s starostjo in rangom pokojnic, ki so jih nosile.

Različico **Ib**, okrašeno s snopi vrezov, srečujemo na istih najdiščih in mnogokrat v istih kontekstih kot različico **Ia**.¹²⁷⁰ Poleg že omenjenih bogatih grobov iz časa stopnje Stična z raznovrstnim obročastim okrasjem jih zasledimo tudi v preprostejši noši, praviloma v paru, včasih z eno ali dvema fibulama in jantarno ogrlico ter mnogokrat z dvema uhanoma oz. obsenčnikoma. Ta različica se je uporabljala v stopnjah kačastih¹²⁷¹ in cer-toških fibul¹²⁷² kot tudi v negovski stopnji.¹²⁷³ Približno enak časovni razpon zarisujejo tudi magdalenskogorski grobovi 2/6 z Voselce ter 2/39 in 2/55 s Prelog. Čeprav ta različica kronološko ni kdove kako indikativna, pa je pomenljivo dejstvo, da predstavlja povečini manjše obroče, ki bi jih lahko pripisali otroški noši, podobno kot velja za sklenjene obroče različice **Ib**.

Masivne bronaste zapestnice s presegačimi konci, ki so bogato okrašene z različnimi vrezanimi motivi

¹²⁶⁹ Dular J. 2003, 219, T. 50: 8-10, 51: 1-6.

¹²⁷⁰ *Boštanj*: Guštin 1974b, T. 4: 22,26, 9: 5-7,9,10; *Brezje*: Kromer 1959a, T. 4: 4, 15: 6, 26: 11, 27: 4, 40: 1,4, 51: 5; *Brus-nice*: Teržan 1974, T. 12: 4,5,13,14; *Čužnja vas*: Dular J. 2003, T. 17: 1, 22: 5; *Dobrnjič*: Stare V. 1973b, T. 8: 10,11; *Parzinger* 1988–1989, T. 1: 4, 5: 4,5, 9: 2,3, 11: 8,9, 38: 16, 40: 9; *Dragatuš*: Spitzer 1973, T. 15: 11; *Škvor Jernejčič* 2011, T. 13: 4,7,8; *Javor*: Guštin/Knific 1973, T. 4: 13; *Krajna Brda*: Dular J. 2003, T. 54: 9; *Libna*: Guštin 1976, T. 6: 1, 11: 9-11,16,17, 19: 1,4, 31: 12, 32: 6,7, 52: 6,8, 61: 14,15, 63: 7, 69: 15, 70: 4,6,7,9,12; 71: 20,23,27; 78: 10; *Metlika*: Grahek 2004, T. 12: 9,10; *Mokronog*: neobjavljeno, NMS inv. št. P 1732, 1733, 1743, 1744, 1745, 1748, 1749, 1751, 1752, 1773, 1774, 1782, 1783, 1784, 1786, 1939, 1940; *Novo mesto*: Knez 1993, T. 37: 2; *Križ* 1997, T. 4: 2,3, 12: 4,5; *Podzemelj*: Barth 1969, T. 14: 9, 23: 8,9, 42: 8; Dular J. 1978, T. 10: 21,23,25,27; *Roje pri Trebelnem*: Dular J. 2003, T. 26: 8,11, 27: 4,5; *Rovišče*: Stare V. 1962–1963, T. 6: 23,24, 8: 8,9; Dular J. 2003, T. 75: 13, 79: 4,5; *Stična*: Wells 1981, Fig. 66b, 78b, 110a, 181c; Gabrovec et al. 2006, T. 20: 48-53, 42: 1, 52: 12-20, 112: 5/1, 118: 13-15, 121: 23/1,2, 175: 82-88, 186: 40, 188: 1-7, 193: 1,2; *Vače*: Stare F. 1955a, T. 71: 3-7 in neobjavljeni primerki, NHMW inv. št. 6534, 7960–7966, 8103, 8459, 14187; *Velike Malence*: Stare V. 1960–1961, T. 15: 8,9; *Veliki Vinji vrh (Šmarjeta)*: Stare V. 1973a, T. 27: 1,5,7,10,21, 29: 12,13,15, 31: 3, 55: 9,11-19, 57: 3, 60: 21, 66: 7-12; Dular A. 1991, T. 6: 2,4,14, 8: 10,11, 10: 4,6, 40: 12,13, 50: 3, 64: 17,19, 71: 10,11, 72: 19; *Vinkov vrh*: Stare V. 1964–1965, T. 1: 4,5,6, 13: 16,17,20; *Volčje Njive*: Gabrovec 1956, T. 10: 4; *Zagorje*: Gabrovec 1966b, T. 5: 6,7; *Zgornje Mladetiče*: Dular J. 2003, T. 82: 4.

¹²⁷¹ *Brezje*, gr. 13/18: Kromer 1959a, T. 51; *Rovišče*, gr. 2-1884/1: Dular J. 2003, T. 75, 76: 1-4; *Volčje Njive*, gr. 9: Gabrovec 1956, T. 10; Teržan 1976, 384, sl. 54: 6-9.

¹²⁷² *Brezje*, gr. 7/12: Kromer 1959a, T. 26: 10,11; *Dobrnjič*, gr. 19/13: Parzinger 1988–1989, T. 38: 4-16; *Boštanj-Mali Lukovec*, gr. 4: Guštin 1974b, T. 9: 5-10.

¹²⁷³ *Brezje*, gr. 13/51: Kromer 1959a, T. 40: 3,4.

pological analysis of the bone remains from the graves at Stična showed that Grave 5/4 contained an adult female (with 32 anklets on both of her legs), Grave 5/13 contained a mature female (only the set of 16 anklets from one leg has been preserved), while the female from Grave 48/27 (with 11 anklets of various shapes) was aged between 18 and 25.¹²⁶⁷ At Vače, a set of 6 ribbed bracelets and three plain anklets with overlapping ends was found in Grave 46, which also revealed two serpentine fibulae with a saddle-shaped bow and a pendant with anthropomorphic figures and a solar boat attached to one of them.¹²⁶⁸ A similar set was reportedly also found in a tumulus at Dele near Kladije nad Blanco, inside a cremation grave together with a serpentine fibula with a saddle-shaped bow and an amber necklace.¹²⁶⁹ The latter two burials revealed the latest grave groups with sets of ring jewellery. Noteworthy in connection with these rings is that the number of items in a set might be connected with age and rank of the women that wore them.

Variant **Ib**, decorated with stripes of incisions, was documented on the same sites and often in the same grave groups as Variant **Ia**.¹²⁷⁰ Apart from the already discussed rich graves from the Stična phase, with ring jewellery of various variants, examples of Variant **Ib** also formed part of a simpler costume, usually in pairs, sometimes with one or two fibulae and an amber necklace and often with two ear- or temple-rings. This variant

¹²⁶⁷ Gabrovec et al. 2006, 32 f, 133, 141.

¹²⁶⁸ Teržan 2003, T. 6.

¹²⁶⁹ Dular J. 2003, 219, T. 50: 8-10, 51: 1-6.

¹²⁷⁰ *Boštanj*: Guštin 1974b, T. 4: 22,26, 9: 5-7,9,10; *Brezje*: Kromer 1959a, T. 4: 4, 15: 6, 26: 11, 27: 4, 40: 1,4, 51: 5; *Brus-nice*: Teržan 1974, T. 12: 4,5,13,14; *Čužnja vas*: Dular J. 2003, T. 17: 1, 22: 5; *Dobrnjič*: Stare V. 1973b, T. 8: 10,11; *Parzinger* 1988–1989, T. 1: 4, 5: 4,5, 9: 2,3, 11: 8,9, 38: 16, 40: 9; *Dragatuš*: Spitzer 1973, T. 15: 11; *Škvor Jernejčič* 2011, T. 13: 4,7,8; *Javor*: Guštin/Knific 1973, T. 4: 13; *Krajna Brda*: Dular J. 2003, T. 54: 9; *Libna*: Guštin 1976, T. 6: 1, 11: 9-11,16,17, 19: 1,4, 31: 12, 32: 6,7, 52: 6,8, 61: 14,15, 63: 7, 69: 15, 70: 4,6,7,9,12; 71: 20,23,27; 78: 10; *Metlika*: Grahek 2004, T. 12: 9,10; *Mokronog*: unpublished, NMS Inv. Nos. P 1732, 1733, 1743, 1744, 1745, 1748, 1749, 1751, 1752, 1773, 1774, 1782, 1783, 1784, 1786, 1939, 1940; *Novo mesto*: Knez 1993, T. 37: 2; *Križ* 1997, T. 4: 2,3, 12: 4,5; *Podzemelj*: Barth 1969, T. 14: 9, 23: 8,9, 42: 8; Dular J. 1978, T. 10: 21,23,25,27; *Roje pri Trebelnem*: Dular J. 2003, T. 26: 8,11, 27: 4,5; *Rovišče*: Stare V. 1962–1963, T. 6: 23,24, 8: 8,9; Dular J. 2003, T. 75: 13, 79: 4,5; *Stična*: Wells 1981, Figs. 66b, 78b, 110a, 181c; Gabrovec et al. 2006, T. 20: 48-53, 42: 1, 52: 12-20, 112: 5/1, 118: 13-15, 121: 23/1,2, 175: 82-88, 186: 40, 188: 1-7, 193: 1,2; *Vače*: Stare F. 1955a, T. 71: 3-7 and unpublished examples, NHMW Inv. Nos. 6534, 7960–7966, 8103, 8459, 14187; *Velike Malence*: Stare V. 1960–1961, T. 15: 8,9; *Veliki Vinji vrh (Šmarjeta)*: Stare V. 1973a, T. 27: 1,5,7,10,21, 29: 12,13,15, 31: 3, 55: 9,11-19, 57: 3, 60: 21, 66: 7-12; Dular A. 1991, T. 6: 2,4,14, 8: 10,11, 10: 4,6, 40: 12,13, 50: 3, 64: 17,19, 71: 10,11, 72: 19; *Vinkov vrh*: Stare V. 1964–1965, T. 1: 4,5,6, 13: 16,17,20; *Volčje Njive*: Gabrovec 1956, T. 10: 4; *Zagorje*: Gabrovec 1966b, T. 5: 6,7; *Zgornje Mladetiče*: Dular J. 2003, T. 82: 4.

(različica **Ic**), so v dolenski halštatski sredini bolj ali manj omejene na stopnjo Stična,¹²⁷⁴ pripadale pa so prestižnejšim ženskim opravam.

Zapestnice z rombičnim presekom so v dolenski noši redke¹²⁷⁵ in so nemara prežitek iz časa kulture žarnih grobišč.¹²⁷⁶ Železnodobne primerke takih zapestnic z vzhodnoalpskega prostora je zbral Egg in pokazal na sorodnost s primerki iz oddaljenega grško-ilirskega sveta, kjer so datirani v pozno geometrijsko in protokorintsko obdobje.¹²⁷⁷

Na Dolenskem so ženske in deklice v času stopenj Ljubljana IIB in IIIa oz. Podzemelj nosile razen železnega nakita tudi bronaste sklenjene zapestnice različic Ia–c, tj. gladke brez okrasa ali okrašene z vrezanimi motivi. Okras s snopi vrezov (različica Ib) se v glavnem pojavlja na zapestnicah manjših dimenzij, zato bi lahko dejali, da je indikativen predvsem za otroško nošo. V stopnji Stične so se uveljavile gladke bronaste zapestnice in nanožnice s presegačimi stanjšanimi konci (različice IIa–c), ki ponekod sestavljajo večdelne garniture. Taka noša je značilna predvsem za čas stopnje Stična. V tem času zasledimo tudi redke primerke zapestnic z rombičnim presekom, ki se morda navezujejo na žarnogrobiščno tradicijo. V mlajšem halštatskem obdobju pa so gladke polno ulite zapestnice iz bron nosili le še otroci in moški.

POLNE NAREBRENE ZAPESTNICE IN NANOŽNICE

Tipološke značilnosti. Bronast narebren obročast nakit kaže v osnovnih shemah iste značilnosti kot gladek. Eni obroči so sklenjeni (sl. 111: 1, 4, 12, 13), drugi imajo razprte (sl. 111: 2, 5, 7) ali presegačice stanjšane konce (sl. 111: 3, 6, 11, 14–16), nekateri primerki imajo zaključka oblikovana tako, da se komplementarno uje-

¹²⁷⁴ *Libna*: Guštin 1976, T. 49: 14, 70: 5, 71: 24; *Mokronog*: neobjavljeno, NMS inv. št. P 1710, 1711, 1718, 1719, 1739; *Novo mesto*: Knez 1986, T. 54: 3; *Podzemelj*: Barth 1969, T. 43: 1; Dular J. 1978, T. 11: 27; *Rovišče*: Stare V. 1962–1963, T. 8: 5,17; *Stična*: Wells 1981, Fig. 53a, 155d; Gabrovec et al. 2006, T. 19: 42,43, 90: 157/5,6, 96: 2,3, 140: 7,8, 175: 76–78, 186: 41, 189: 6,7, 193: 3,4; *Vače*: Stare F. 1955a, T. 76: 4 in neobjavljena primerka, NHMW inv. št. 14188, 14231; *Veliki Vinji vrh (Šmarjeta)*: Stare V. 1973a, T. 27: 14,18; Dular A. 1991, T. 13: 24,25, 72: 16,17.

¹²⁷⁵ *Boštanj*: Guštin 1974b, T. 4: 21; *Libna*: Guštin 1976, T. 45: 10; *Ljubljana*: Puš 1982, T. 52: 4; *Stična*: Wells 1981, Fig. 123d; *Vače*: Stare F. 1955a, T. 71: 1.

¹²⁷⁶ *Ormož*: Tomanič-Jevremov 1988–1989, T. 10: 2,3, 15: 4; *Pobrezje*: Pahič 1972, T. 38: 19; *Ruše*: Müller-Karpe 1959, T. 110E: 1,2, 111A: 5.

¹²⁷⁷ Egg 1996, 215 ss, Abb. 126, 127.

was in use in the Serpentine¹²⁷¹ and Certosa Fibulae phases,¹²⁷² but also in the Negova phase.¹²⁷³ Roughly the same time span can be determined for Grave 2/6 at Voselca and Graves 2/39 and 2/55 at Preloge, which revealed this variant rings. Although the variant is not particularly revealing in terms of chronology, it is nevertheless important in that it mostly takes the shape of smaller rings attributable to children's costume, similarly as was observed for the annular rings of Variant Ib.

Solid bronze bracelets with overlapping ends and rich incised decoration (Variant **Ic**) are, within the Early Iron Age community of Dolenska, more or less limited to the Stična phase.¹²⁷⁴ They formed part of the female costume of some prestige.

Bracelets with a rhombic cross-section were rarely worn in the Dolenska costume¹²⁷⁵ and may represent a relict from the Urnfield culture period.¹²⁷⁶ The Iron Age examples of these bracelets from the Eastern Alps were collectively treated by Egg, who showed their similarity to those from the distant Greco-Illyrian world, where they date to the Late Geometric and Proto-Corinthian periods.¹²⁷⁷

In the Ljubljana IIB and IIIa (= Podzemelj) phases, women and girls in Dolenska wore iron jewellery but also bronze annular bracelets of Variants Ia–c, plain and either undecorated or with incised decoration. Stripes of incisions mostly adorned small-sized bracelets (Variant Ib), which might primarily have formed part of the children's costume. In the Stična phase, plain bronze bracelets and anklets with overlapping tapering ends became popular (Variants IIa–c), sometimes appearing

¹²⁷¹ *Brezje*, Gr. 13/18: Kromer 1959a, T. 51; *Rovišče*, Gr. 2-1884/1: Dular J. 2003, T. 75, 76: 1-4; *Volčje Njive*, Gr. 9: Gabrovec 1956, T. 10; Teržan 1976, 384, Abb. 54: 6-9.

¹²⁷² *Brezje*, Gr. 7/12: Kromer 1959a, T. 26: 10,11; *Dobrnič*, Gr. 19/13: Parzinger 1988–1989, T. 38: 4-16; *Boštanj-Mali Lukovec*, Gr. 4: Guštin 1974b, T. 9: 5-10.

¹²⁷³ *Brezje*, Gr. 13/51: Kromer 1959a, T. 40: 3,4.

¹²⁷⁴ *Libna*: Guštin 1976, T. 49: 14, 70: 5, 71: 24; *Mokronog*: unpublished, NMS Inv. Nos. P 1710, 1711, 1718, 1719, 1739; *Novo mesto*: Knez 1986, T. 54: 3; *Podzemelj*: Barth 1969, T. 43: 1; Dular J. 1978, T. 11: 27; *Rovišče*: Stare V. 1962–1963, T. 8: 5,17; *Stična*: Wells 1981, Figs. 53a, 155d; Gabrovec et al. 2006, T. 19: 42,43, 90: 157/5,6, 96: 2,3, 140: 7,8, 175: 76–78, 186: 41, 189: 6,7, 193: 3,4; *Vače*: Stare F. 1955a, T. 76: 4 and unpublished examples, NHMW Inv. Nos. 14188, 14231; *Veliki Vinji vrh (Šmarjeta)*: Stare V. 1973a, T. 27: 14,18; Dular A. 1991, T. 13: 24,25, 72: 16,17.

¹²⁷⁵ *Boštanj*: Guštin 1974b, T. 4: 21; *Libna*: Guštin 1976, T. 45: 10; *Ljubljana*: Puš 1982, T. 52: 4; *Stična*: Wells 1981, Fig. 123d; *Vače*: Stare F. 1955a, T. 71: 1.

¹²⁷⁶ *Ormož*: Tomanič-Jevremov 1988–1989, T. 10: 2,3, 15: 4; *Pobrezje*: Pahič 1972, T. 38: 19; *Ruše*: Müller-Karpe 1959, T. 110E: 1,2, 111A: 5.

¹²⁷⁷ Egg 1996, 215 ff, Abb. 126, 127.

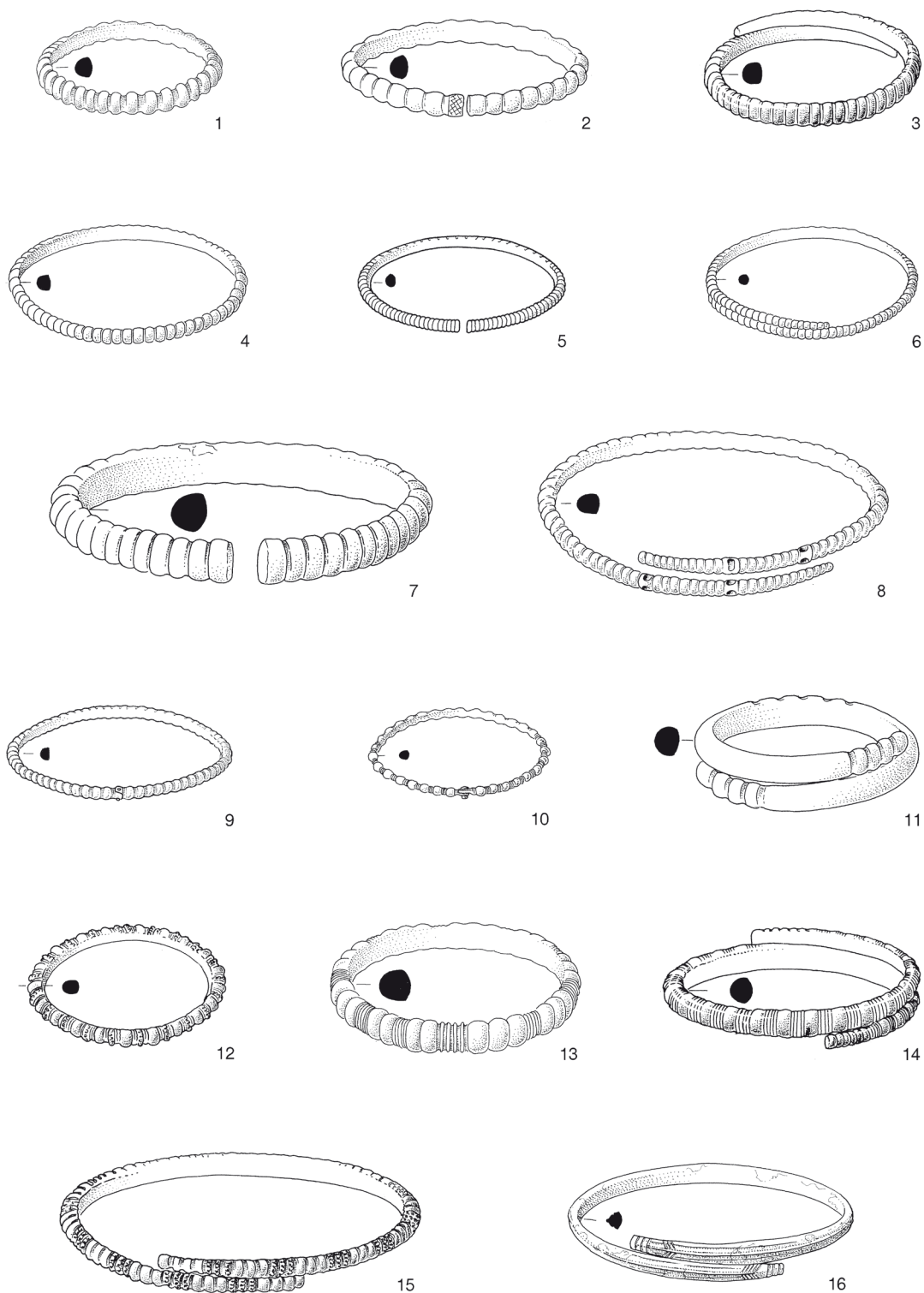

Sl. 111: Tipi bronastih polno ulitih narebrenih zapestnic in nanožnic z Magdalenske gore. M. = 1:2.

Fig. 111: Types of solid and ribbed bronze bracelets and anklets from Magdalenska gora. Scale = 1:2.

1 – Preloge, gr. 13/102 (IIIa); 2 (IIIb), 3 (IIIc), 11, 14 (IVb), 16 – najdbe brez znanih grobnih celot v NMS / finds without preserved grave group in the NMS; 4 – Voselca, gr. 2/20 (IIIa); 5 – Preloge, gr. 13/163 (IIIb); 6 – Voselca, gr. 2/21 (IIIc); 7 – Preloge, gr. 2/h (IIIb); 8 – Preloge, gr. 13/90 (IIIId); 9 – Preloge, gr. 13/79 (IIId); 10 – Preloge, gr. 2/30 (IVd); 12 – Preloge, gr. VI/2 (IVc); 13 – Preloge, gr. 13/117 (IVa); 15 – Preloge, gr. X/75 (IVc).

mata in sta preluknjana (sl. 111: 8–10). Tudi v tej zvrsti obročastega okrasja nastopajo masivnejši in tanjši primerki, ločujejo pa se tudi po kompoziciji okrasa in širini reber. Različica **IIIa** združuje enakomerno narebrene sklenjene obroče (sl. 111: 1, 4), različica **IIIb** predstavlja enakomerno narebrene obroče z dotikajočimi ali razprtimi zaključki, ki so mestoma okrašeni z vrezanim mrežastim motivom (sl. 111: 2, 5, 7). Značilnost različice **IIIc** predstavljajo stanjšani presegojoči konci (sl. 111: 3, 6), medtem ko sta pri različici **IIId** konca staknjena in speta z zakovico ali pa sta zaključka presegojoča in imata pare luknjic za spenjanje (sl. 111: 8–10).

V naslednjo skupino spada narebreni nakit, ki ima bolj razgibano kompozicijo okrasa, drugače pa se ponovijo vse različice kot v prejšnji skupini. Sklenjene obroče z okrasom iz širših reber in vmesnimi pasovi vrezov predstavlja različica **IVa** (sl. 111: 13), take obroče s presegojočimi konci pa različica **IVb** (sl. 111: 14). Drugačno variacijo okrasa predstavljajo primerki različice **IVc**, ki imajo vmesna polja med rebri izpolnjena s snopi vrezov ter vrstami bunčic (sl. 111: 12, 15). Primerek različice **IVd** pa ima zaključka staknjena in speta z zakovico (sl. 111: 10).

Poseben tip predstavlja zapestnica s trikotastim presekom, ki je vzdolžno našlebljena in okrašena z vrezi v obliki smrekove vejice ob profiliranih zaključkih (sl. 111: 16).

Lega in kontekst. Narebrene sklenjene zapestnice različice **IIIa** (sl. 111: 1, 4) so na Magdalenski gori zabeležene izključno v skeletnih grobovih.¹²⁷⁸ Pripadnice te skupnosti so jih nosile posamično ali v paru in običajno skupaj s kačasto fibulo ter ogrlico iz debelih jantarnih jagod, medtem ko so steklene jagode v teh kombinacijah bolj skromno zastopane (sl. 112). Pokojnici v grobovih 4/1 in 13/102 s Prelog naj bi imeli po poročanju Pečnika in Brattine par takih zapestnic na desnici, okostje v grobu V/18 z Laščika pa na levisi. En primerek je zabeležen še v okviru nezanesljive grobne celote 2/19 z Voselce. Pečnik namreč govori o štirih fibulah, eni zapestnici, dveh uhanih, jantarni ogrlici in eni stekleni jagodi ter rombični pasni sponi, medtem ko je inventariziranih kar sedem fibul (fibula s stekleno oblogo, dve čolničasti, dve kačasti, ena certoška ter ena zgodnjelatenska), razen tega trije uhani ter še dve votli zapestnici. Tanjši drobno narebreni sklenjeni obroči te različice (sl. 111: 4)¹²⁷⁹ se pojavljajo v grobovih, ki so ležali dokaj plitvo v gomilah. V teh sestavih zasledimo trakasto fibulo, certoško vrste II in samostrelne fibule, pavkasto fibulo ter drobne pisane in raznolike steklene jagode (sl. 112).

¹²⁷⁸ Hencken 1978, Fig. 15b, 124b, 159a; Tecco Hvala/Dular/Kocuvan 2004, T. 28B: 3,4, 29C: 3, 65A: 24, 99B: 1, 138: 6.

¹²⁷⁹ Hencken 1978, Fig. 76, 124a, 224a, 229a,b, 303b; Tecco Hvala/Dular/Kocuvan 2004, T. 18B: 1, 30D: 9, 30C: 4,5, 37B: 8,9, 57C: 3,4, 126: 20, 137C: 4,5, 139A: 4,5.

in sets. Also used in this phase were rare examples of bracelets with a rhombic cross-section, which might be seen as relicts of the Urnfield culture tradition. In the Late Hallstatt period, the plain solid bracelets of bronze were only worn by children and men.

SOLID RIBBED BRACELETS AND ANKLETS

Typological characteristics. Bronze ribbed rings show the same basic characteristics as the plain jewellery. Some are annular (fig. 111: 1, 4, 12, 13), some penannular (fig. 111: 2, 5, 7) and some have overlapping and tapering ends (fig. 111: 3, 6, 11, 14–16), while there are also examples with corresponding perforated ends (fig. 111: 8–10). This type of ring jewellery includes examples of varied thickness and varied composition of decoration and rib width. Variant **IIIa** has equally wide ribs (fig. 111: 1, 4). Variant **IIIb** bears equally wide ribs and is either penannular or with touching ends that are sometimes decorated with reticular incisions (fig. 111: 2, 5, 7). The characteristic of Variant **IIIc** are tapering overlapping ends (fig. 111: 3, 6), while the ends in Variant **IIId** may either be riveted together or overlap and with pairs of holes for attachment (fig. 111: 8–10).

The next group consists of ribbed jewellery with a more varied composition of decoration, while the formal variants are the same as above. Annular rings with decoration consisting of wide ribs and intermediary stripes of incisions constitute Variant **IVa** (fig. 111: 13), while Variant **IVb** comprises rings with overlapping ends (fig. 111: 14). A different decorative variation can be found on examples of Variant **IVc** with spaces between ribs filled with stripes of incisions and rows of dots (fig. 111: 12, 15). The example of Variant **IVd** has touching ends bound by a rivet (fig. 111: 10).

A special type can also be seen in a bracelet with a triangular cross-section and decoration consisting of longitudinal grooves and pine-sprig incisions beside the moulded ends (fig. 111: 16).

Position and context. Ribbed annular bracelets of Variant **IIIa** (fig. 111: 1, 4) have at Magdalenska gora only been found in inhumation graves.¹²⁷⁸ They were worn by the female representatives of the community either singly or in pairs, and usually in combination with a serpentine fibula and a necklace of large amber beads, while glass beads were rarely included (fig. 112). As reported by Pečnik and Brattina, the females in Graves 4/1 and 13/102 at Prelog had a pair of such bracelets on the right arm, while the skeleton from Grave V/18 at Laščik had one on the left arm. A further example was recorded within Grave Group 2/19 from Voselca, which is unreliable since Pečnik writes of four fibulae, one bracelet,

¹²⁷⁸ Hencken 1978, Figs. 15b, 124b, 159a; Tecco Hvala/Dular/Kocuvan 2004, T. 28B: 3,4, 29C: 3, 65A: 24, 99B: 1, 138: 6.

Gom. / Gr. Tum. / Gr.	Pokop / Burial rite	Sex / Age	Tip zapestnic / nanožnic Types of bracelets / anklets	Št. zapestnic / No. of bracelets	Št. nanožnic / No. of anklets	Fibule / Fibulae	Igle / Pins	Uhani / Earrings	Ovratnice / Torques	Jantar / Amber	Steklene jagode / Glass beads	Au nakit / Au jewellery	Obeski / Pendants	Prstan / Finger-ring	Pasne sponke / Belts	Pasni okovi / Belt attachments	Sekire / Axes	Sulice / Spears	Noži / Knives	Lončenina / Pottery	Vijički / Spindle whorls	Koščen tul / Bone tube			
P IV/35	S	F	IIIa	1																					
P X/13	S	F									x												1		
P 2/22	?	F				1					x	1													
P 13/102	S	F				1-2					x												1		
L V/18	S	F				2																			
P 2/28	?	F				2						x													
P VII/6	?	F				2																	1		
P 4(IV)/1	S	F				1		1?															2		
P II/3	S	F				1		1																	
P 2/27	?	F				1		1		2		x													
V 2/19	S	F				1		4		2		x	1				1								
L V/38	S?	F				2		1				x											1		
P 2/19	?	F				2		1				x													
V 2/17	?	F				2		1				x													
P 2/40	?	F				2		1				x													
V 2/20	?	F				2		2				x	4												
P VII/10	S	F				2		3				x	x		2	2									
P 2/68	?	F				2		2															1		
P X/22	S	F+I		IIIb		2		1				x													
P 2/h	S	F					2		1				x	x										3	
P IV/9	?	F					2							x											
P 13/90	S	F		IIIb+IIIc		1	2																		
P 13/79	S	I?		IIIc		2		1					1?												
P 2/6	?	M	IIIa+IIIc	1+1											x	2			1						
P 13/117	S	F	IVa	2+4*	4*	4	10			x	x	x													
P VI/2	C	I	IVc	2	14*	1				x											2				
V 2/12	S	I	IVb+IIIc	1+1		2	2				x										1	1			
P X/50	S	F	IVb	3		2	1																		
V 2/7	?	I			2		1			1												x			
P 2/30	?	I			1+1*		1				x	x													
P IV/20	S	I			2		1				x?														
P VI/18	C	?			2									1?					1?						

Sl. 112: Struktura pridatkov v grobovih z bronastim polno ulitim narebrenim obročastim nakitom na Magdalenski gori.

* = drugačen tip.

Fig. 112: Structure of goods in the graves with solid and ribbed bronze ring jewellery at Magdalenska gora. * = other type.

V grobu 2/6 s Prelog pa ta različica zapestnic nastopa v kombinaciji z dvema uhatima sekirama in nožem. Ti pokopi govorijo za čas certoške in negovske stopnje, ko so zapestnice dozdevno nosili tudi moški.

Masivni narebreni obroči z razprtimi konci različice IIIb (sl. 111: 2, 7 in sl. 112) izvirajo pretežno iz gomil na Prelogah.¹²⁸⁰ O grobu 2/h je Pečnik zapisal, da je bila v njem pokopana ženska v leseni krsti, ki je

two earrings, one amber necklace, one glass bead and a rhombic belt clasp, while the museum inventory book lists as many as seven fibulae (one with glass overlay, two boat, two serpentine, one Certosa and one Early La Tène), three earrings and two hollow bracelets. Thinner annular rings with fine ribs of this variant (fig. 111: 4)¹²⁷⁹ appear in graves dug at rather shallow depths into the

¹²⁸⁰ Hencken 1978, Fig. 46a, 262q, 313b,c, Tecco Hvala/Dular/Kocuvan 2004, T. 12A: 3,4, 96C: 1, 150: 11-13,19-21.

¹²⁷⁹ Hencken 1978, Figs. 76, 124a, 224a, 229a,b, 303b; Tecco Hvala/Dular/Kocuvan 2004, T. 18B: 1, 30D: 9, 30C: 4,5, 37B: 8,9, 57C: 3,4, 126: 20, 137C: 4,5, 139A: 4,5.

Gom. / Gr. Tum. / Gr.	Pokop / Burial rite	Spol / Starost Sex / Age	Tip zapestnic / nanožnic Types of bracelets / anklets	Št. zapestnic / No. of bracelets	Št. nanožnic / No. of anklets	Fibule / Fibulae	Igle / Pins	Uhani / Earrings	Ovratnice / Torques	Steklene jagode / Glass beads	Jantar / Amber	Scepter / Sceptre	Diadem / Diadem	Aunakit / Au jewellery	Prstan / Finger-ring	Obeski / Pendants	Pasne sponje / Belts	Sekire / Axes	Sulice / Spears	Noži / Knives	Lončevina / Pottery	Vijčki / Spindle whorls	
P 13/128	♂	F	IIIc	1																			
L V/16	♂	F														1							
P 13/17	♂	I?			1													1					1
P VII/15	♂	M?			1							x							1				
L V/13-14	♂	M+F			1							x									1		
P X/42	♂	F			1				1			x											
P X/31	♂	F			2																		
P IV/29	?	F			2																		
P 2/75	♂	F			2																		
P 13/66	♂	I			2												1						1
P 13/77	♂	F+I			2+2					1	x	x						Fe					1
P VII/8	♂	M?			2															1	1		
P 2/21	?	I			2						x												
P X/10	♂	F			2				2			x											1
P 2/61	?	F			2				1														2
V 2/10	♂	F			2						2												
P IV/2	?	I			2		1		4														
P X/38	♂	F			2		1	1															1
P 13/152	♂	F			2		1		2		x	x	1					Fe					6
P 13/88	♂	F			2		1		4		x	x											1
P 13/49	♂	F			2		1		2			x											1
V 2/21	?	F			2		2		x		x	x											
P X/67	♂	I			2		2	1			x												
P 2/64	♂	F			2		2				x												2
V 2/9	?	F			2		2		6														1
P 4(IV)/2	♂	F			1		2?		6			x											?
P 2/83	♂	F			1		2		3														
P I/2	?	F			1		1											Fe					1
P VIII/9	?	I			1		1				x												
V 2/6	♂	I			1+5*		4		2		br		1	x									3 1
P VII/40	♂	F+I?			3+2*	28*	9		4	6	x	x											5
P 2/65	?	I			2	2	1		1		x												1
P VI/33a	?	I		2	1	1																	
P 2/15	♂	F		2	2	1																1 4	
P X/72	♂	F		5		2					x			x									

Sl. 113: Struktura pridatkov v grobovih z bronastim polno ulitim narebrenim obročastim nakitom na Magdalenski gori.

* = drugačen tip.

Fig. 113: Structure of goods in the graves with solid and ribbed bronze ring jewellery at Magdalenska gora. * = other type.

imela na vsaki nogi po en tak obroč, razen tega še debelo jantarno ogrlico in fibulo s stekleno oblogo. Z enakimi fibulami nastopajo tudi v opravi vodilne predstavnice stopnje Stična (Preloge, gr. VII/40). Pokojnica v grobu 13/90 je po Brattinovich navedbah imela en tak obroč na zapestju desne roke, medtem ko sta ji gležnja krasila dva

tumuli. The grave groups with these bracelets include a band bow fibula, a Type II Certosa fibula, crossbow fibulae, a kettledrum fibula and small multicoloured and variously shaped glass beads (fig. 112). In Grave 2/6 from Preloge, the bracelet variant was found in combination with two shaft-hole axes and a knife. The latter graves

narebrena obroča s presegajočima koncema in parom luknjic za spenjanje (različice IIIId). Zapestnici različice IIIb je na desnici nosila tudi ženska, pokopana skupaj z otrokom v grobu X/22 na Prelogah.

Najpogostejši je narebren obročasti nakit s presegajočimi stanjšanimi konci, tj. različica IIIc (sl. 111: 3, 6),¹²⁸¹ ki so ga nosile tako ženske in otroci kot tudi nekateri moški (sl. 113). V otroških opravah nastopa skupaj z gladkim obročastim nakitom ter raznimi tipi fibul – dvortasto, čolničastimi,¹²⁸² kačastimi,¹²⁸³ certoškimi vrste I,¹²⁸⁴ dolgonožnimi, drobnimi ločnimi¹²⁸⁵ in vzhodnoalpskimi živalskimi fibulami.¹²⁸⁶ Med spremnimi pridatki zasledimo tudi votle ovratnice in zapestnice ali nanožnice,¹²⁸⁷ kar kaže, da so otroci nosili take zapestnice vse mlajše halštatsko obdobje. Primerka iz groba X/67 s Prelog sta bila bojda obešena na kačasto fibulo, medtem ko je imel otrok v grobu 13/77 na vsaki roki po eno tako zapestnico, drugi par pa je ležal skupaj z votlo ovratnico ter jantarnimi in steklenimi jagodami pri nogah odrasle osebe, ki je imela pri kolkih še železno pravokotno pasno spono. V kombinaciji z moškimi pridatki se pojavljajo v sestavih iz negovskega časa, za kar govorijo uhate sekire in železni obročki med spremljajočimi pridatki.¹²⁸⁸ V sklopu grobne celote VII/8 s Prelog je objavljena še jantarna ogrlica, ki je Goldberg ne omenja. Vendar je tak nakit najbolj značilen za žensko nošo. V preprostejših opravah nastopata ena ali dve tovrstni zapestnici brez drugih dodatkov ali pa so bili ti zelo skromni (sl. 113). Pokojnici v grobovih 13/128 s Prelog in V/16 z Laščika sta imeli zapestnico menda na desnici. Bogatejše predstavnice so prav tako nosile le po eno ali dve narebreni zapestnici v kombinaciji z eno ali dvema fibulama, uhani, jantarnimi in steklenimi ogrlicami ter drugim okrasjem (sl. 113). Prve narebreni zapestnice s presegajočimi konci zasledimo že med garniturami gladkega obročastega nakita v stopnji Stična 2.¹²⁸⁹ Zastopane pa so tudi v kombinacijah s kačastimi fibulami,¹²⁹⁰ s trortastimi vrste VII po Ogrinovi, drobnimi ločnimi fibulami, s certoškimi vrst II in V ali z

¹²⁸¹ Hencken 1978, Fig. 4a, 6a, 32b, 37n, 38a, 62b, 68, 170b, 121a, 123a, 208b, 226d, 227c-g, 234d, 248b,c, 262f, 270e, 283a, 301d, 315d, 321, 330c, 333a, 352 l,m, 357e,f, 359cc; Tecco Hvala/Dular/Kocuvan 2004, T. 18B: 1,2, 28A: 3,4, 29B: 5,6, 54B: 3,4, 57B: 3,4, 58A: 5,6, 61A: 1,2, 62C: 5, 65B: 10, 70B: 1, 80B: 4,5, 89A: 5,6, 91: 1-4, 95B: 13,14, 111D: 1, 118: 12,13, 126: 16-18, 134B: 9,10, 134C: 6,7, 134D: 9, 139B: 19,20, 149: 13-25,28,29, 150: 16-18.

¹²⁸² *Voselca*, gr. 2/6; *Preloge*, gr. VIII/9.

¹²⁸³ *Voselca*, gr. 2/12; *Preloge*, gr. IV/2.

¹²⁸⁴ *Preloge*, gr. X/67.

¹²⁸⁵ *Preloge*, gr. 2/56, X/24.

¹²⁸⁶ *Preloge*, gr. VI/33a.

¹²⁸⁷ *Preloge*, gr. 2/65, 13/77, VI/33a, X/24.

¹²⁸⁸ *Preloge*, gr. 2/6, VII/8, VII/15.

¹²⁸⁹ *Preloge*, gr. VII/40, 13/163, *Voselca*, gr. 2/6.

¹²⁹⁰ *Preloge*, gr. IV/2, X/38, 13/88, 13/152.

point to a Certosa and Negova phase date, when they were worn also by men.

Solid penannular and ribbed rings of Variant IIIb (fig. 111: 2, 7 and fig. 112) mostly originate from the tumuli at Preloge.¹²⁸⁰ For Grave 2/h Pečnik wrote that the female, buried inside a wooden coffin, had one such ring on each of her legs, as well as a thick amber necklace and a fibula with a glass overlay. They appear in combination with the same type of fibulae in the grave of the leading female representative of the Stična phase (Preloge, Gr. VII/40). The deceased in Grave 13/90 had, according to Brattina, one such bracelet on the wrist of her right hand, while her ankles were adorned by two ribbed anklets with overlapping ends and pairs of attachment holes (Variant IIIId). Two bracelets of Variant IIIb were also worn on the right arm by a female buried together with a child in Grave X/22 at Preloge.

The most numerous represented solid and ribbed ring jewellery was that of Variant IIIc with overlapping and tapering ends (fig. 111: 3, 6).¹²⁸¹ It was worn by women and children, but also by certain men (fig. 113). As part of the children's costume, it appears together with plain ring jewellery and various types of fibulae, namely two-knobbed, boat,¹²⁸² serpentine,¹²⁸³ Type I Certosa,¹²⁸⁴ long-footed, small bow¹²⁸⁵ and East Alpine animal-headed fibulae.¹²⁸⁶ The associated grave goods also include hollow torques and bracelets or anklets,¹²⁸⁷ which shows that children wore this type of bracelets throughout the Late Hallstatt period. The two examples from Grave X/67 at Preloge were reportedly threaded onto a serpentine fibula. The child buried in Grave 13/77 had one such bracelet on each arm and another pair lying together with a hollow torque and amber and glass beads at the feet of an adult, who also had an iron rectangular belt clasp at the hips. The Variant IIIc rings appear in combination with male attributes in grave groups from the Negova phase, as suggested by the associated shaft-hole axes and iron rings.¹²⁸⁸ Published within Grave Group VII/8 from Preloge was also an amber necklace not mentioned by Goldberg. This jewellery variant, however, was more typical of the female

¹²⁸⁰ Hencken 1978, Figs. 46a, 262q, 313b,c; Tecco Hvala/Dular/Kocuvan 2004, T. 12A: 3,4, 96C: 1, 150: 11-13,19-21.

¹²⁸¹ Hencken 1978, Figs. 4a, 6a, 32b, 37n, 38a, 62b, 68, 170b, 121a, 123a, 208b, 226d, 227c-g, 234d, 248b,c, 262f, 270e, 283a, 301d, 315d, 321, 330c, 333a, 352 l,m, 357e,f, 359cc; Tecco Hvala/Dular/Kocuvan 2004, T. 18B: 1,2, 28A: 3,4, 29B: 5,6, 54B: 3,4, 57B: 3,4, 58A: 5,6, 61A: 1,2, 62C: 5, 65B: 10, 70B: 1, 80B: 4,5, 89A: 5,6, 91: 1-4, 95B: 13,14, 111D: 1, 118: 12,13, 126: 16-18, 134B: 9,10, 134C: 6,7, 134D: 9, 139B: 19,20, 149: 13-25,28,29, 150: 16-18.

¹²⁸² *Voselca*, Gr. 2/6; *Preloge*, Gr. VIII/9.

¹²⁸³ *Voselca*, Gr. 2/12; *Preloge*, Gr. IV/2.

¹²⁸⁴ *Preloge*, Gr. X/67.

¹²⁸⁵ *Preloge*, Gr. 2/56, X/24.

¹²⁸⁶ *Preloge*, Gr. VI/33a.

¹²⁸⁷ *Preloge*, Gr. 2/65, 13/77, VI/33a, X/24.

¹²⁸⁸ *Preloge*, Gr. 2/6, VII/8, VII/15.

vzhodnoalpsko živalsko fibulo.¹²⁹¹ Pokojnica v grobu X/42 s Prelog je imela tak obroč na desnici, medtem ko ju je nosila ženska, pokopana v grobu 2/15 na Prelogah, na nogah, na rokah pa je imela votli zapestnici.

Z Magdalenske gore sta znana tudi dva primerka narebrenih nanožnic, ki imata pare luknjic za spenjanje presegaajočih koncev (*sl. 111: 8*), najdena pa sta bila v grobu 13/90 s Prelog skupaj z narebreno zapestnico različice IIIc.¹²⁹² Nekatero zapestnico iz gomile V na Laščiku in grobov VII/30, 13/79 s Prelog ter med predmeti brez ohranjenih grobnih celot imajo konce staknjene in spete z zakovico (*sl. 111: 9*).¹²⁹³ O grobu 13/79 je Brattina zapisal, da sta ležali na rokah slabo ohranjenega okostja z majhno lobanjo, medtem ko je pripadnost takih nanožnic grobni celoti VII/30 vprašljiva, saj sta bili po Goldbergovih navedbah odkriti skoraj 2 m nad grobom s to oznako. Tovrsten nakit označujem kot različico **IIIId** (*sl. 112*).

Nakit z bolj razgibano kompozicijo okrasa uvrščam med različice tipa IV. Masivna sklenjena obroča različice **IVa** (*sl. 111: 13* in *sl. 112*) je nosila bogato opravljena ženska v grobu 13/117 s Prelog.¹²⁹⁴ Krasile so jo še drobne ločne fibule, zlati lističi in množica steklenih in jantarnih jagod, na desni podlakti je imela poleg dveh masivnih še eno debelo votlo zapestnico ter dve enaki na levi roki, na nogah pa par votlih nanožnic. Ob pokojničinem desnem kolenu je ležalo deset lepih valjastih uhanov ter še štiri zapestnice in dve votli nanožnici, kar govori za čas certoške stopnje.

Različica **IVb** s presegaajočimi konci (*sl. 111: 14* in *sl. 112*)¹²⁹⁵ se pojavlja v otroških oz. dekliskih opravah skupaj s trortasto fibulo vrste I po Ogrinovi (Preloge, gr. 2/48), s fibulami s stekleno in koščeno oblogo (Preloge, gr. 13/163), pa tudi s kačastimi fibulami in trakastimi uhanji (Voselca, gr. 2/12) ter s svinčeno ovratnico (Voselca, gr. 2/7). Preostali primerki takih zapestnic so zabeleženi v ženskih grobovih VI/18 in X/50 s Prelog, kjer prav tako nastopajo v pari. Pri okostju v grobu X/50 sta bili po Goldbergovem poročilu najdeni na levi strani prsnega koša skupaj z majhno iglo ter dvema fibulama, na levisi pa še ena votla zapestnica. Grob VI/18 naj bi predstavljal žgani pokop z žaro, pokrito s kamnito ploščo; v žari so bile sežgane kosti, dve zapestnici in kos železa.

Različica **IVc**, ki jo krasi niz bunčic med rebri, je redka (*sl. 111: 12* in *sl. 112*).¹²⁹⁶ En primerek manjših dimenzij je objavljen v sklopu pridatkov žarnega groba

costume. The simple costume included one or two such bracelets either without or with very few other goods (*fig. 113*). The two females in Graves 13/128 at Preloge and V/16 at Laščik reportedly had such a bracelet on the right arm. Wealthier women wore only one or two ribbed bracelets, but they also had one or two fibulae, earrings, amber and glass necklaces and other jewellery items (*fig. 113*). The earliest ribbed bracelets with overlapping ends were found in sets of plain ring jewellery of the Stična 2 phase.¹²⁸⁹ They also appear in combinations with serpentine fibulae,¹²⁹⁰ three-knobbed of Group VII after Ogrin, small bow, Types II and V Certosa as well as an East Alpine animal-headed fibula.¹²⁹¹ The female in Grave X/42 from Preloge had such a ring on her right arm. The female in Grave 2/15 at Preloge wore it on her leg, while her arms were adorned by two hollow bracelets.

Magdalenska gora also revealed two examples of ribbed anklets with pairs of holes for binding the overlapping ends (*fig. 111: 8*). They were found in Grave 13/90 at Preloge together with a ribbed bracelet of Variant IIIc.¹²⁹² Some of the bracelets from Tumulus V at Laščik, Graves VII/30 and 13/79 at Preloge, and among stray finds, show riveted ends (*fig. 111: 9*).¹²⁹³ For the bracelets from Grave 13/79, Brattina noted that they were found on the arms of a poorly preserved skeleton with a small skull. Grave Group VII/30, on the other hand, is not reliable, since Goldberg wrote of the anklets to have been found almost 2m above the grave. Jewellery of this variant is marked as **IIIId** (*fig. 112*).

Jewellery with more varied decoration constitutes Type IV with variants. Two solid annular rings of Variant **IVa** (*fig. 111: 13* and *fig. 112*) were worn by a richly accoutred female in Grave 13/117 at Preloge.¹²⁹⁴ She also wore small bow fibulae, gold leaves and a multitude of glass and amber beads, two solid and one thick and hollow bracelet on the right forearm, a further two on the left arm, and a pair of hollow anklets on her legs. Found beside her right knee were ten beautiful cylindrical earrings, four bracelets and two hollow anklets, which speak of a Certosa phase date.

Variant **IVb** with overlapping ends (*fig. 111: 14* and *fig. 112*)¹²⁹⁵ appears in children's or girl's burials together with a three-knobbed fibula of Type I after Ogrin (Preloge, Gr. 2/48), with fibulae with a glass and bone overlay (Preloge, Gr. 13/163), with serpentine fibulae and band earrings (Voselca, Gr. 2/12), as well as with a lead torque

¹²⁸⁹ Preloge, Gr. VII/40, 13/163, Voselca, Gr. 2/6.

¹²⁹⁰ Preloge, Gr. IV/2, X/38, 13/88, 13/152.

¹²⁹¹ Preloge, Gr. I/2, 2/64; Voselca, Gr. 2/9, 2/15, 2/21, 2/83.

¹²⁹² Tecco Hvala/Dular/Kocuvan 2004, T. 96C: 2,3.

¹²⁹³ Hencken 1978, Figs. 170a, 250c; Tecco Hvala/Dular/Kocuvan 2004, T. 93 A: 3,4, 149: 26,27.

¹²⁹⁴ Tecco Hvala/Dular/Kocuvan 2004, T. 106: 56,57.

¹²⁹⁵ Hencken 1978, Figs. 192b,c, 339f; Tecco Hvala/Dular/Kocuvan 2004, T. 47A: 10,11, 124: 27, 126: 15,19, 132C: 3,4, 134D: 8, 150: 4.

¹²⁹¹ Preloge, gr. I/2, 2/64; Voselca, gr. 2/9, 2/15, 2/21, 2/83.

¹²⁹² Tecco Hvala/Dular/Kocuvan 2004, T. 96C: 2,3.

¹²⁹³ Hencken 1978, Fig. 170a, 250c; Tecco Hvala/Dular/Kocuvan 2004, T. 93 A: 3,4, 149: 26,27.

¹²⁹⁴ Tecco Hvala/Dular/Kocuvan 2004, T. 106: 56,57.

¹²⁹⁵ Hencken 1978, Fig. 192b,c, 339f; Tecco Hvala/Dular/Kocuvan 2004, T. 47A: 10,11, 124: 27, 126: 15,19, 132C: 3,4, 134D: 8, 150: 4.

¹²⁹⁶ Hencken 1978, Fig. 56, 174k,l.

VI/2 s Prelog skupaj s trortasto fibulo vrste I po Ogrinovi, z jantarnimi jagodami in s štirinajstimi gladkimi nanožnicami z nesklenjenimi konci. Grob je menda ležal blizu sredine gomile in le 20 cm pod površjem. Fragmenti podobnih zapestnic so bili odkriti tudi pri otroškem okostju v grobu IV/20 na Prelogah. Med grobnimi pridatki Goldberg navaja še jagode in fibulo z obeski. Enak okras imata tudi nanožnici s presegačoma zaključkoma iz groba X/75 (sl. 111: 15), kjer pa ju Goldberg ne omenja.

Drobna narebrena zapestnica s pasovi vrezov med rebri, ki ima zakovičena konca (sl. 111: 10 in sl. 112),¹²⁹⁷ predstavlja edini tak primer, najden pa je bil v grobu 2/30 s Prelog skupaj z gladko zapestnico, jantarno ogrlico in certoško fibulo vrste II. Med najdbami brez ohranjenih grobnih celot v ljubljanskem muzeju sta tudi dva primerka zapestnic, ki so okrašene z rebri, razporejenimi v skupinah (sl. 111: 11), eden pa je objavljen v sklopu groba II/18 s Prelog, ki pa ga Goldberg v opisu groba ne omenja.¹²⁹⁸ Po premerih sodeč gre za otroški nakit.

Muzej v Ljubljani hrani tudi zapestnico z bolj trikotnim presekom in vzdolžno nažlebljenim okrasom (sl. 111: 16),¹²⁹⁹ ki se stilno precej razlikuje od vsega ostalega obročastega nakita in predstavlja osamljen primer na Magdalenski gori.

Razširjenost in časovni okvir. Narebreni nakit v obliki sklenjenih obročev različice **IIIa** je bil v dolenski halštatski skupnosti precej razširjen, največ primerkov pa je znanih iz Podzemlja, medtem ko druga najdišča po številu za njim znatno zaostajajo.¹³⁰⁰ Zaznamo ga lahko že v času stopnje Stična 2, vendar je bolj pogost v stopnjah kačastih in certoških fibul, v Novem mestu pa je izpričan še v negovskem času,¹³⁰¹ primerki iz mlajših grobov pa so običajno tanjši.

¹²⁹⁷ Tecco Hvala/Dular/Kocuvan 2004, T. 31C: 7.

¹²⁹⁸ Hencken 1978, Fig. 27d; Tecco Hvala/Dular/Kocuvan 2004, T. 150: 6,7.

¹²⁹⁹ Tecco Hvala/Dular/Kocuvan 2004, T. 150: 14.

¹³⁰⁰ *Boštanj*: Guštin 1974b, T. 17: 1; *Brusnice*: Teržan 1974, T. 2: 2; *Dobrnič*: Parzinger 1988–1989, T. 9: 11; *Kaplja vas*: Dular J. 2003, T. 84: 7,8; *Libna*: Guštin 1976, T. 14: 13, 15: 3, 28: 16; *Metlika*: Grahek 2004, T. 5: 1; *Novo mesto*: Knez 1986, T. 20: 14; 21: 9, 49: 1, 54: 8,9; id. 1993, T. 25: 2,3; 27: 3,4; *Podzemelj*: Barth 1969, T. 24: 6; Dular J. 1978, T. 6: 13–18,20, 7: 4–8,10,11,13,14, 10: 1–3; *Rovišče*: Stare V. 1962–1963, T. 8: 1; Dular J. 2003, T. 70: 6, 76: 3,4, 78: 4,5; *Stična*: Wells 1981, Fig. 83b; Gabrovec et al. 2006, T. 186: 38; *Suhadole*: Dular J. 2003, T. 90: 3,6; *Valična vas*: Teržan 1973, T. 7: 9,11, 8: 5, 10: 7; *Velike Malence*: Stare V. 1960–1961, T. 14: 3; *Veliki Vinji vrh (Šmarjeta)*: Dular A. 1991, T. 55: 15, 64: 13; *Vače*: neobjavljeno, NHMW inv. št. 7597; *Vinkov vrh*: Stare V. 1964–1965, T. 3: 2, 4: 3,4,14,15, 12: 4, 13: 18; *Vrhpeč*: Dular J. 2003, T. 8: 6; *Zagorica pri Čatežu*: ibid., T. 37: 9; *Zagorje*: Gabrovec 1966b, T. 10: 20,21; Draksler 2007, sl. 11: 7,8.

¹³⁰¹ *Znančeve njive, gr. 2/19, Kapiteljska njiva, gr. A/50*: Knez 1986, T. 21, 73, 49: 1–3.

(Voselca, Gr. 2/7). Further examples of this variant were recorded in female Graves VI/18 and X/50 at Preloge, also in pairs. In Grave X/50, they were, according to Goldberg's report, found on the left side of the skeleton's chest together with a small pin and two fibulae, while a hollow bracelet was found on the left arm. Grave VI/18 was a cremation burial with the urn covered by a stone slab, whereby the urn contained cremated bones, two bracelets and a piece of iron.

Variant **IVc**, decorated with a row of dots between the ribs, is rare (fig. 111: 12 and fig. 112).¹²⁹⁶ One example, small in size, was published among the goods of urn Grave VI/2 from Preloge together with a three-knobbed fibula of Type I after Ogrin, amber beads and fourteen plain penannular anklets. The grave was reportedly situated near the centre of the tumulus and only 20cm beneath the surface. Fragments of similar bracelets were also found beside a child's skeleton in Grave IV/20 at Preloge. Apart from the bracelet fragments, Goldberg lists beads and a fibula with pendants. The same decoration can be observed on two anklets with overlapping ends from Grave X/75 (fig. 111: 15), though not mentioned there by Goldberg.

The small ribbed bracelet with stripes of incisions between the ribs and riveted ends (fig. 111: 10 and fig. 112)¹²⁹⁷ is the only example of its kind and was found in Grave 2/30 at Preloge together with a plain bracelet, amber necklace and a Type II Certosa fibula. The finds without preserved grave groups kept in the museum in Ljubljana include two bracelets decorated with groups of ribs (fig. 111: 11). One such example was also published within Grave II/18 from Preloge, though it is not mentioned there by Goldberg.¹²⁹⁸ Judging from their diameters, these items were worn by children.

The museum in Ljubljana keeps a bracelet with a triangular cross-section and longitudinal grooves (fig. 111: 16).¹²⁹⁹ Stylistically, it differs considerably from all other ring jewellery and represents the only example of its kind from Magdalenska gora.

Distribution and time frame. Ribbed annular jewellery of Variant **IIIa** was quite common in the Hallstatt community of Dolenska, with by far the most examples recovered at Podzemelj.¹³⁰⁰ The earliest examples date

¹²⁹⁶ Hencken 1978, Figs. 56, 174k,l.

¹²⁹⁷ Tecco Hvala/Dular/Kocuvan 2004, T. 31C: 7.

¹²⁹⁸ Hencken 1978, Fig. 27d; Tecco Hvala/Dular/Kocuvan 2004, T. 150: 6,7.

¹²⁹⁹ Tecco Hvala/Dular/Kocuvan 2004, T. 150: 14.

¹³⁰⁰ *Boštanj*: Guštin 1974b, T. 17: 1; *Brusnice*: Teržan 1974, T. 2: 2; *Dobrnič*: Parzinger 1988–1989, T. 9: 11; *Kaplja vas*: Dular J. 2003, T. 84: 7,8; *Libna*: Guštin 1976, T. 14: 13, 15: 3, 28: 16; *Metlika*: Grahek 2004, T. 5: 1; *Novo mesto*: Knez 1986, T. 20: 14; 21: 9, 49: 1, 54: 8,9; id. 1993, T. 25: 2,3; 27: 3,4; *Podzemelj*: Barth 1969, T. 24: 6; Dular J. 1978, T. 6: 13–18,20, 7: 4–8,10,11,13,14, 10: 1–3; *Rovišče*: Stare V. 1962–1963, T. 8: 1; Dular J. 2003, T. 70: 6, 76: 3,4, 78: 4,5; *Stična*: Wells 1981, Fig. 83b; Gabrovec et al. 2006, T. 186: 38; *Suhadole*: Dular J.

Tudi različica **IIIb** je znana na številnih najdiščih.¹³⁰² Večinoma predstavlja nanožnice, ki so se nosile praviloma v paru. Največ primerkov je zabeleženih med najdbami iz okolice Velikega Vinjega vrha (Šmarjeta) in z Libne. Ta različica je sočasna različici IIIa.

Najbolj pogosto okrasje ne le v magdalenskogorskih opravah, temveč nasploh v dolenski halštatski noši, predstavlja narebren obročasti nakit s presegačimi konci različice **IIIc**.¹³⁰³ Prve primerke takih zapestnic zasledimo že v stopnji Stična med večdelnimi garniturami zapestnic in nanožnic, pa tudi v skromnejših opravah tistega časa.¹³⁰⁴ V stopnji kačastih fibul so postale standardni kos ženske noše,¹³⁰⁵ sestavljene iz para zapestnic in para nanožnic, v kombinaciji z eno ali več fibulami, debelo jantarno ogrlico, velikokrat pa tudi s parom ozkih trakastih uhanov s presegačimi zaključki. V otroški noši narebrenih nanožnic ni opaziti, otroci so praviloma nosili po eno ali dve taki zapestnici skupaj s fibulo ter ogrlicami iz drobnih jantarnih ali steklenih jagod. Kombinacije z raznovrstnimi certoškimi fibulami pa dokazujejo, da je bil tovrsten nakit v uporabi še v certoški stopnji.¹³⁰⁶

Nanožnici različice **IIIc** s parom luknjic za spejnanje z Magdalenske gore še najbolj spominjata na primerke z Libne in Vač, ki imajo presegačjo zaključka speta z bronasto objemko.¹³⁰⁷ Na Vačah jih srečamo v kombinaciji z železno pasno spono ter nožem s ploščatim nastavkom za ročaj in zakovicami, ki označuje negovsko stopnjo.¹³⁰⁸ Obročje, ki imajo zakovičene konce, pa je že Teržanova izpostavila kot značilnost časa

¹³⁰² Grahek 2004, 148, sl. 39.

¹³⁰³ Ibid., 146, sl. 38.

¹³⁰⁴ Npr. *Brezje*, gr. 1/43, 7/36, 13/15: Kromer 1959a, 66, 70, T. 17: 11-16, 22: 1-8, 48: 1-7; *Brusnice*, gr. 5/2: Teržan 1974, T. 1: 6-12; *Bučni vrh pri Velikih Orlah*, gr. 4: Guštin 1974b, 90, T. 10: 6-18; *Libna-Volavškova gomila*, gr. 6: Guštin 1976, T. 16-21; *Lopanec pri Kaplji vasi*, gr. 2/1: Dular J. 2003, T. 84: 1-6; *Stična*, gr. 48/36, 5/4, 5/13: Gabrovec et al. 2006, 133 ss, T. 27: 1-5, 109-111, 118.

¹³⁰⁵ Npr. *Brezje*, gr. 2/1, 7/10, 7/33, 7/39, 7/41, 7/42, 13/6, 13/40: Kromer 1959a, T. 1: 2-5, 19: 5-11, 25: 11-15, 31: 1-8, 33: 3-8, 34, 35, 52: 8-11; *Brusnice*, gr. 16/1: Teržan 1974, T. 11: 4-14; *Dobrníč*, gr. 13/5, 14/1, 18/17: Parzinger 1988-1989, T. 19: 1-11, 18: 11-19, 34: 7-9; *Javor*, gr. 9: Guštin/Knific 1973, T. 3: 1-4; *Novo mesto-Znančeve njive*, gr. 1/2: Knez 1986, T. 5: 8-12; *Stična*, gr. IV/2, IV/12, IV/53, V/17: Wells 1981, Fig. 56, 67, 107, 127; *Stična*, gr. 48/26, 48/29, 48/37, 48/48, 48/81, 48/136, 48/138, 48/162, 48/163, 48/172: Gabrovec et al. 2006, T. 15, 24, 28: 1-3, 31: 1-4, 47, 78, 79, 93: 1-13, 94: 1-15, 99; *Volčje Njive*, gr. 4: Gabrovec 1956, T. 5, 6; Teržan 1976, 384 s, sl. 54: 10-16.

¹³⁰⁶ *Brezje*, gr. 1/14, 2/4, 7/2: Kromer 1959a, 52, 61 s, T. 3: 4-9, 47: 1-7, 49: 1-3; *Novo mesto-Znančeve njive*, gr. 4/4, 4/20, 4/21: Knez 1986, 90 s, T. 37: 10-14, 38: 17-20, 70; Teržan 2003, 69, T. 4: 1, 4; *Rovišče*, gr. 1-1883/22: Dular J. 2003, T. 70.

¹³⁰⁷ *Libna*: Guštin 1976, T. 78: 4,6,7; *Vače*: Stare F. 1955a, T. 91: 2, 92: 1, 98: 13.

¹³⁰⁸ Gabrovec 1987, 74, sl. 6: 22.

to the Stična 2 phase, while it was most popular in the Serpentine and Certosa Fibulae phases, at Novo mesto it even dates to the Negova phase.¹³⁰¹ Later examples are usually thinner.

Variant **IIIb** was also documented at numerous sites,¹³⁰² most numerous in the vicinity of Veliki Vinji vrh (Šmarjeta) and at Libna. It mostly comes in the shape of anklets and was usually worn in pairs. This variant is contemporary to that of IIIa.

The commonest not only at Magdalenska gora, but across the whole of Dolenska, is Variant **IIIc** with overlapping ends.¹³⁰³ The earliest examples of such bracelets date to the Stična phase and form part of sets composed of bracelets and anklets, but also as part of a poorer costume of the phase.¹³⁰⁴ In the Serpentine Fibulae phase, this jewellery became the standard component of the female costume,¹³⁰⁵ composed of a pair of bracelets and pair of anklets, in combination with one or more fibulae, a thick amber necklace and often with a pair of flat wire earrings with overlapping ends. No ribbed anklets were recorded as part of the children's costume; children usually wore one or two ribbed bracelets together with a fibula and necklaces of small amber or glass beads. Combinations with Certosa fibulae of various types prove that this kind of jewellery remained in use in the Certosa phase.¹³⁰⁶

2003, T. 90: 3,6; *Valična vas*: Teržan 1973, T. 7: 9,11, 8: 5, 10: 7; *Velike Malence*: Stare V. 1960-1961, T. 14: 3; *Veliki Vinji vrh (Šmarjeta)*: Dular A. 1991, T. 55: 15, 64: 13; *Vače*: unpublished, NHMW Inv. No. 7597; *Vinkov vrh*: Stare V. 1964-1965, T. 3: 2, 4: 3,4,14,15, 12: 4, 13: 18; *Vrhpeč*: Dular J. 2003, T. 8: 6; *Zagorica pri Čatežu*: *ibid.*, T. 37: 9; *Zagorje*: Gabrovec 1966b, T. 10: 20,21; Drakšler 2007, Abb. 11: 7,8.

¹³⁰¹ *Znančeve njive*, Gr. 2/19, *Kapiteljska njiva*, Gr. A/50: Knez 1986, T. 21, 73, 49: 1-3.

¹³⁰² Grahek 2004, 148, Fig. 39.

¹³⁰³ *Ibid.*, 146, Fig. 38.

¹³⁰⁴ For example *Brezje*, Gr. 1/43, 7/36, 13/15: Kromer 1959a, 66, 70, T. 17: 11-16, 22: 1-8, 48: 1-7; *Brusnice*, Gr. 5/2: Teržan 1974, T. 1: 6-12; *Bučni vrh near Velike Orle*, Gr. 4: Guštin 1974b, 90, T. 10: 6-18; *Libna-Volavšek Tum./Gr. 6*: Guštin 1976, T. 16-21; *Lopanec near Kaplja vas*, Gr. 2/1: Dular J. 2003, T. 84: 1-6; *Stična*, Gr. 48/36, 5/4, 5/13: Gabrovec et al. 2006, 133 ff, T. 27: 1-5, 109-111, 118.

¹³⁰⁵ For example *Brezje*, Gr. 2/1, 7/10, 7/33, 7/39, 7/41, 7/42, 13/6, 13/40: Kromer 1959a, T. 1: 2-5, 19: 5-11, 25: 11-15, 31: 1-8, 33: 3-8, 34, 35, 52: 8-11; *Brusnice*, Gr. 16/1: Teržan 1974, T. 11: 4-14; *Dobrníč*, Gr. 13/5, 14/1, 18/17: Parzinger 1988-1989, T. 19: 1-11, 18: 11-19, 34: 7-9; *Javor*, Gr. 9: Guštin/Knific 1973, T. 3: 1-4; *Novo mesto-Znančeve njive*, Gr. 1/2: Knez 1986, T. 5: 8-12; *Stična*, Gr. IV/2, IV/12, IV/53, V/17: Wells 1981, Figs. 56, 67, 107, 127; *Stična*, Gr. 48/26, 48/29, 48/37, 48/48, 48/81, 48/136, 48/138, 48/162, 48/163, 48/172: Gabrovec et al. 2006, T. 15, 24, 28: 1-3, 31: 1-4, 47, 78, 79, 93: 1-13, 94: 1-15, 99; *Volčje Njive*, Gr. 4: Gabrovec 1956, T. 5, 6; Teržan 1976, 384 f, Abb. 54: 10-16.

¹³⁰⁶ *Brezje*, Gr. 1/14, 2/4, 7/2: Kromer 1959a, 52, 61 f, T. 3: 4-9, 47: 1-7, 49: 1-3; *Novo mesto-Znančeve njive*, Gr. 4/4, 4/20, 4/21: Knez 1986, 90 f, T. 37: 10-14, 38: 17-20, 70; Teržan 2003, 69, T. 4: 1, 4; *Rovišče*, Gr. 1-1883/22: Dular J. 2003, T. 70.

Ha D3.¹³⁰⁹ Največ primerkov je zabeleženih v Valični vasi, Dolenjskih Toplicah in v Novem mestu.¹³¹⁰ V Novem mestu se ta različica pojavlja v kombinaciji s certoško fibulo vrste XIII, v Veliki Kostrevnici s predrto pasno spono in fibulama zgodnjelatske sheme, v Dolenjskih Toplicah pa z vzhodnoalpsko živalsko fibulo ter s fibulo zgodnjelatske oblike. Nekateri primerki z Vač, iz Stične, Brezja in Podturna kažejo, da so morda na podoben način predmete tudi popravljali.¹³¹¹

Narebrene zapestnice z bolj razgibano kompozicijo menjajočih se širokih in ozkih reber različice **IVa** niso prav pogoste,¹³¹² zasledimo jih pretežno v bogatejših ženskih grobovih iz certoške stopnje. V starejšem kontekstu, ki ga označuje velika čolničasta fibula, značilna za stopnjo Stična, je bila najdena v Lopancu pri Kaplji vasi.

Različica **IVb** s snopi vrezov med rebri je številne zastopana,¹³¹³ največ primerkov je znanih iz okolice Velikega Vinjega vrha, vendar nimajo ohranjenih grobnih celot. Kronološko izpovedni konteksti kažejo, da so vzniknile že v stopnji Stična 2, uporabljale pa so se še v stopnjah kačastih in certoških fibul. Po dimenzijah sodeč so v glavnem pripadale otroškim opravam.

Različico **IVc**, okrašeno z nizi bunčic med rebri, srečamo razen na Magdalenski gori še v Stični, Novem mestu in v okolici Velikega Vinjega vrha (Šmarjete).¹³¹⁴ V Novem mestu je par takih zapestnic spadal k opravi pokojnice z zlatim diademom iz časa certoške stopnje

¹³⁰⁹ Teržan 1973, 683.

¹³¹⁰ *Brezje*: Kromer 1959a, T. 17: 4; *Dolenjske Toplice*: Teržan 1976, T. 81: 4,5,9,11; *Novo mesto*: Gabrovec 1968, T. 7: 1,2,3,5; *Podzemelj*: Dular 1978, T. 8: 29,30; *Vače*: Stare 1955a, T. 90: 6 in neobjavljena primerka, NHMW inv. št. 7959, 8475; *Valična vas*: Teržan 1973, 683, T. 8: 1-4,6,8,13,14; 9, 1-8,11; 10: 2; *Velika Kostrevnica*: Stare F. 1953, 266 ss, T. 7: 3.

¹³¹¹ *Brezje*: Kromer 1959a, T. 39: 6; *Podturn*: Dular J. 2003, T. 25: 4; *Stična*: Wells 1981, Fig. 182n; *Vače*: neobjavljeno, NHMW inv. št. 6736.

¹³¹² *Brusnice*: Teržan 1974, T. 13: 6,7; *Kaplja vas-Lopaneec*: Dular J. 2003, T. 84: 5,6; *Libna*: Guštin 1976, T. 62: 1, 78: 17,18; *Novo mesto*: Knez 1986, T. 20: 14, 24: 17; *Podzemelj*: Dular J. 1978, T. 7: 3,9,12, 9: 15,17,18,20,21, 10: 6,11; *Veliki Vinji vrh (Šmarjeta)*: Stare V. 1973a, T. 26: 1,3,4,6.

¹³¹³ *Brezje*: Kromer 1959a, T. 22: 7; *Brezje pri Raki*: Stare/Škaler 1958–1959, T. 9: 3,5; *Brusnice*: Teržan 1974, T. 16: 15; *Čužnja vas*: Dular J. 2003, T. 22: 5, 28: 1; *Dobrnič*: Stare V. 1973b, T. 8: 8; *Libna*: Guštin 1976, T. 44: 6, 58: 13; *Mala Hubajnica*: Stare/Škaler 1958–1959, T. 9: 13; *Mokronog*: neobjavljeno, NMS inv. št. P 1710, 1711, 1718, 1719; *Novo mesto*: Knez 1986, T. 50: 4; *Podzemelj*: Dular J. 1978, T. 10: 7,8; *Rovišče*: Stare V. 1962–1963, T. 8: 5,17; Dular J. 2003, T. 73: 4,5; *Stična*: Wells 1981, Fig. 66b; Gabrovec et al. 2006, T. 35: 2, 118: 16-18; *Vače*: Stare F. 1955a, T. 70: 9, 71: 11,12,14; *Valična vas*: Teržan 1973, T. 8: 9; *Veliki Vinji vrh (Šmarjeta)*: Stare V. 1973a, T. 27: 2, 13-15,17,19, 29: 6,7, 31: 11, 55: 24, 60: 18,19; Dular A. 1991, T. 4: 10,11, 61: 12,13,17, 71: 7-9; *Vinkov vrh*: Stare V. 1964–1965, T. 1: 7,9.

¹³¹⁴ *Mokronog*: neobjavljeno, NMS inv. št. P 1726, 1727; *Novo mesto*: Knez 1986, T. 18: 3, 36: 7; *Stična*: Wells 1981, Fig. 118b; *Veliki Vinji vrh (Šmarjeta)*: Stare V. 1973a, T. 26: 11,17.

The two anklets of Variant **IIIId** with pairs of attachment holes from Magdalenska gora are closest to the examples found at Libna and Vače, which show overlapping ends bound by a bronze clip.¹³⁰⁷ At Vače, these examples were found in combination with an iron belt clasp and a knife with a flat tang and rivets, the latter marking the Negova phase.¹³⁰⁸ Rings with riveted ends have been marked as a characteristic of Ha D3 already by Teržan.¹³⁰⁹ Most examples of the type were recorded at Valična vas, Dolenjske Toplice and Novo mesto.¹³¹⁰ At Novo mesto, the variant appears in combination with a Type XIII Certosa fibula, at Velika Kostrevnica with an openwork belt clasp and two fibulae of the Early La Tène scheme, while at Dolenjske Toplice it was found together with an East Alpine animal-headed fibula and a fibula of the Early La Tène scheme. Several examples from Vače, Stična, Brezje and Podturn indicate that riveting was also used when repairing broken pieces of jewellery.¹³¹¹

Ribbed bracelets with a more varied composition of alternating wide and narrow ribs of Variant **IVa** are not very frequent,¹³¹² found mostly in rich female graves of the Certosa phase. At Lopaneec near Kaplja vas, one was found in an earlier context, marked by a large boat fibula as dating to the Stična phase.

Variant **IVb**, with stripes of incisions between the ribs, is better represented.¹³¹³ The greatest number of its examples was found in the vicinity of Veliki Vinji vrh,

¹³⁰⁷ *Libna*: Guštin 1976, T. 78: 4,6,7; *Vače*: Stare F. 1955a, T. 91: 2, 92: 1, 98: 13.

¹³⁰⁸ Gabrovec 1987, 74, fig. 6: 22.

¹³⁰⁹ Teržan 1973, 683.

¹³¹⁰ *Brezje*: Kromer 1959a, T. 17: 4; *Dolenjske Toplice*: Teržan 1976, T. 81: 4,5,9,11; *Novo mesto*: Gabrovec 1968, T. 7: 1,2,3,5; *Podzemelj*: Dular 1978, T. 8: 29,30; *Vače*: Stare 1955a, T. 90: 6 and unpublished examples, NHMW Inv. No. 7959, 8475; *Valična vas*: Teržan 1973, 683, T. 8: 1-4,6,8,13,14; 9, 1-8,11; 10: 2; *Velika Kostrevnica*: Stare F. 1953, 266 ff, T. 7: 3.

¹³¹¹ *Brezje*: Kromer 1959a, T. 39: 6; *Podturn*: Dular J. 2003, T. 25: 4; *Stična*: Wells 1981, Fig. 182n; *Vače*: unpublished, NHMW Inv. No. 6736.

¹³¹² *Brusnice*: Teržan 1974, T. 13: 6,7; *Kaplja vas-Lopaneec*: Dular J. 2003, T. 84: 5,6; *Libna*: Guštin 1976, T. 62: 1, 78: 17,18; *Novo mesto*: Knez 1986, T. 20: 14, 24: 17; *Podzemelj*: Dular J. 1978, T. 7: 3,9,12, 9: 15,17,18,20,21, 10: 6,11; *Veliki Vinji vrh (Šmarjeta)*: Stare V. 1973a, T. 26: 1,3,4,6.

¹³¹³ *Brezje*: Kromer 1959a, T. 22: 7; *Brezje pri Raki*: Stare/Škaler 1958–1959, T. 9: 3,5; *Brusnice*: Teržan 1974, T. 16: 15; *Čužnja vas*: Dular J. 2003, T. 22: 5, 28: 1; *Dobrnič*: Stare V. 1973b, T. 8: 8; *Libna*: Guštin 1976, T. 44: 6, 58: 13; *Mala Hubajnica*: Stare/Škaler 1958–1959, T. 9: 13; *Mokronog*: unpublished, NMS Inv. Nos. P 1710, 1711, 1718, 1719; *Novo mesto*: Knez 1986, T. 50: 4; *Podzemelj*: Dular J. 1978, T. 10: 7,8; *Rovišče*: Stare V. 1962–1963, T. 8: 5,17; Dular J. 2003, T. 73: 4,5; *Stična*: Wells 1981, Fig. 66b; Gabrovec et al. 2006, T. 35: 2, 118: 16-18; *Vače*: Stare F. 1955a, T. 70: 9, 71: 11,12,14; *Valična vas*: Teržan 1973, T. 8: 9; *Veliki Vinji vrh (Šmarjeta)*: Stare V. 1973a, T. 27: 2, 13-15,17,19, 29: 6,7, 31: 11, 55: 24, 60: 18,19; Dular A. 1991, T. 4: 10,11, 61: 12,13,17, 71: 7-9; *Vinkov vrh*: Stare V. 1964–1965, T. 1: 7,9.

(Znančeve njive, gr. 2/8); nosila pa jih je tudi ženska, pokopana ob poglavarju z negovsko čelado, v znamenitem grobu 4/3.

Zapestnice z bolj trikotnim presekom in vzdolžno nažlebljene so tujki v dolenski halštatski sredini. Posamični primerki so zastopani na Magdalenski gori, v Stični¹³¹⁵ in na Libni, kjer je bila taka zapestnica najdena v naselbinski plasti II. faze, datirani v Ha C2.¹³¹⁶ Primerjali bi jih lahko z zapestnico iz Tarquinije, v t. i. Tomba del Guerriero, ki je med drugim vseboval še narebreno in gladko zapestnico s presegajočimi konci ter votla bronasta obroča.¹³¹⁷ Sorodne izdelke srečamo še v Verucchiu¹³¹⁸ ter v Padski nižini in na severnem Tirolskem, datirani pa so v drugo polovico 7. in na začetek 6. st. pr. n. št.¹³¹⁹

Narebreni stil se je v dolenski halštatski sredini pojavil že v stopnji Stična, največji razmah je doživel v stopnji kačastih fibul, obdržal pa se je vse do izteka halštatskega obdobja, kar je zgovoren dokaz, da gre za tipično prvino noše te pokrajine in izdelke lokalnih delavnic. V oblikovnih značilnostih se v narebrenem obročastem okrasju ponovi enak vzorec kot pri gladkem nakitu. V obeh primerih prevladujejo obroči s presegajočimi konci, masivnejši izdelki običajno nastopajo v bogatejših opravah, tanjši pa v skromnejših. Ženske so jih nosile tudi na gležnjih, običajno na vsaki nogi po enega, medtem ko v otroških opravah narebrene nanožnice niso zastopane. Za otroško nošo so značilne zapestnice različice IVb, ki so okrašene s snopi vrezov med rebri. V mlajši certoški in v negovski stopnji se pojavljajo tudi primerki z zakovičenimi konci (različica IIIId). Takrat so narebrene zapestnice oz. narokvice nosili tudi nekateri moški. Zapestnice z bolj trikotnim presekom in vzdolžno nažlebljene predstavljajo posebnost v dolenski skupnosti, kamor so prišle nemara iz italjskih delavnic v času stopnje Stična.

Narebren obročasti nakit je v primerjavi z gladkimi polno ulitimi izdelki precej bolj pogost, razmerje med njima je približno 2 : 3 v prid narebrenemu. Po številu kosov prednjači Veliki Vinji vrh (Šmarjeta), ki mu sledita Magdalenska gora in Stična.

¹³¹⁵ Wells 1981, 66, Fig. 99b.

¹³¹⁶ Guštin 1976, 16, 24, T. 81: 11.

¹³¹⁷ Hencken 1968a, 207, Fig. 186n,o,p, 188c,d.

¹³¹⁸ Gentili 2003, T. 26: 27, 59: 21,22, 83:18.

¹³¹⁹ Marzatico 1999, 481, T. I: d. (*Rubiera, Zambana, Fliess*).

though without preserved grave groups. Chronologically revealing contexts show that they first appeared already in the Stična 2 phase and continued to be used in the Serpentine and Certosa Fibulae phases. Their size indicates the children's costume.

Variant IVc, decorated with rows of dots between the ribs, was documented at Magdalenska gora, but also Stična, Novo mesto and in the vicinity of Veliki Vinji vrh (Šmarjeta).¹³¹⁴ At Novo mesto, a pair of such bracelets formed part of the costume of the woman with a gold diadem from the Certosa phase (Znančeve njive, Gr. 2/8); but they were also worn by the woman buried beside the chieftain with a Negova helmet in famous Grave 4/3.

Bracelets with a triangular cross-section and longitudinal grooves represent foreign objects within the Early Iron Age milieu of Dolenska. Individual examples were found at Magdalenska gora, Stična¹³¹⁵ and Libna. At the latter site, one such bracelet was documented in a settlement layer of Phase 2, dated to Ha C2.¹³¹⁶ It could be compared to a bracelet from Tarquinia, from Tomba del Guerriero, which also contained a ribbed and a plain bracelet with overlapping ends as well as two hollow bronze rings.¹³¹⁷ Similar products were found at Verruchio,¹³¹⁸ in the Po Plain and in northern Tyrol, where they date to the second half of the seventh and the beginning of the sixth century BC.¹³¹⁹

The ribbed style appeared in the Dolenska Hallstatt milieu already in the Stična phase, reached the peak of popularity in the Serpentine Fibulae phase and persisted to be used until the end of the Hallstatt period. This is clear evidence of it representing a distinctive element of the local costume, but also an element of local production. In formal varieties, ribbed ring jewellery comes in the same range as the plain one; both show a prevalence of rings with overlapping ends and the thick examples usually form part of rich and thinner ones of poor costume. Women also wore it on their ankles, usually one per leg, while no ribbed anklets were found in children's burials. The children's costume was rather characterised by bracelets of Variant IVb, decorated with stripes of incisions between the ribs. Apart from those, examples with riveted ends of Variant IIIId also appeared in the Late Certosa and Negova phases. At that time, ribbed bracelets and armllets were also worn

¹³¹⁴ *Mokronog*: unpublished, NMS Inv. Nos. P 1726, 1727; *Novo mesto*: Knez 1986, T. 18: 3, 36: 7; *Stična*: Wells 1981, Fig. 118b; *Veliki Vinji vrh (Šmarjeta)*: Stare V. 1973a, T. 26: 11,17.

¹³¹⁵ Wells 1981, 66, Fig. 99b.

¹³¹⁶ Guštin 1976, 16, 24, T. 81: 11.

¹³¹⁷ Hencken 1968a, 207, Figs. 186n,o,p, 188c,d.

¹³¹⁸ Gentili 2003, T. 26: 27, 59: 21,22, 83:18.

¹³¹⁹ Marzatico 1999, 481, T. I: d. (*Rubiera, Zambana, Fliess*).

SPIRALNE ŽIČNATE ALI TRAKASTE ZAPESTNICE IN NAROKVICE

Tipološke značilnosti. Nekatero zapestnice ali narokvice so izdelane iz bronaste spiralno zvite žice ali traku. Po velikosti jih lahko delimo na dve skupini. Majhni spiralni obročki so bodisi neornamentirani, tj. različica **S1** (sl. 114: 1), ali pa imajo vrezan okrasni motiv IIIIXIII, te označujem kot različico **S2** (sl. 114: 2). Spiralne obroče z večjim premerom lahko prav tako delimo na neokrašeno trakasto različico **S3** (sl. 114: 3) ter na primerke, izdelane iz okrogle žice, z nazaj zavrtimi zaključki, ki so razčlenjeni, tj. različica **S4** (sl. 114: 4–6).

Lega in kontekst. Med najdbami brez ohranjenih grobnih celot v zbirki ljubljanskega muzeja sta inventarizirana dva para zapestnic različic **S1** in **S2** (sl. 114: 1, 2), nekaj pa jih zasledimo tudi med pridatki grobov, ki jih hrani Peabodyjev muzej.¹³²⁰ Žičnate zapestnice brez okrasa sta bili najdeni na podlahtnicah okostja v grobu V/4 na Laščiku skupaj s certoško fibulo vrste VIIIf. Dva primerka sta bila odkrita v grobu VIII/3 s Prelog, v katerem je bila domnevno pokopana ženska z otrokom. Goldberg v tem sklopu omenja majhno latensko fibulo, inventarizirana pa je drobna ločna fibula. Majhna trakasta spiralna zapestnica je zabeležena še v sklopu groba VII/31 s Prelog, na katerega so naleteli tik pod rušo, med spremljajočimi najdbami pa nastopajo steklene jagode, drobna fibula srednjelatenske sheme in steklena zapestnica. V sklopu grobne celote IV/38 s Prelog je objavljen primerek, okrašen s snopi vrezov; Goldberg v tem grobu omenja ostanke okostja in delce uhanov.

Narokvice različic **S3** in **S4** (sl. 114: 3, 5 in sl. 115)¹³²¹ so pripadale grobovom, ki so prav tako ležali dokaj plitvo pod površjem. Med inventarjem groba V/29 z Laščika, v katerem sta bila pokopana dva moška s štirimi konji, nastopata dva različna primerka spiralnih narokvic (sl. 114: 3, 5). Pokojnika sta bila opremljena še z negovskima čeladama, pravokotnima pasnima sponama, zgodnjelatenskim mečem, žezlom, priložena jima je bila konjska oprema in bronasto posodje. V grobovih VII/12 in VII/19 s Prelog pa je bila velika spiralna zapestnica najdena v kombinaciji z železno tulasto sekuro in certoško fibulo vrste X. V grobu 13/127 s Prelog je narokvica menda ležala pri nogah slabo ohranjenega okostja, ki mu je bil priložen železen nož s trnastim nastavkom za ročaj. O grobu 2/47 na Prelogah Pečnik poroča, da je bil odkrit 2 ali 3 m globoko v gomili, v njem je ležalo okostje, ki je imelo na desni nadlahtnici štiri obroče, a gre pravzaprav za eno spiralno narokvico s štirimi zavoji (sl. 114: 6 in sl. 115). Od drugih pridatkov iz tega groba so ohranjeni še pravokotna pasna spona, tulasta sekira,

by certain men. Bracelets with a triangular cross-section and longitudinal grooves are not a common item within the Dolenjska community and may have arrived there from Italic workshops in the Stična phase.

Ribbed ring jewellery is better represented in Dolenjska than plain solid jewellery, with their ratio roughly 2 : 3 in favour of the former. The highest number of pieces were found at Veliki Vinji vrh (Šmarjeta), followed by Magdalenska gora and Stična.

SPIRAL WIRE OR BAND BRACELETS AND ARMLETS

Typological characteristics. Bracelets and armlets were also made of a spiral wire or bronze sheet bands. They are divided into two size groups. The small spiral rings are either undecorated, marked as Variant **S1** (fig. 114: 1), or bear an incised IIIIXIII motif, marked as Variant **S2** (fig. 114: 2). Spiral rings of a larger diameter are also divided, into the undecorated band Variant **S3** (fig. 114: 3) and the examples made of wire of a round cross-section with reverted and moulded ends of Variant **S4** (fig. 114: 4–6).

Position and context. The finds without preserved grave groups in the collection of the museum in Ljubljana include two pairs of bracelets of Variants **S1** and **S2** (fig. 114: 1, 2), while some are also to be found among the grave goods in the Peabody Museum.¹³²⁰ As for their findspots, two undecorated wire bracelets were found on the forearms of the skeleton in Grave V/4 at Laščik together with a Type VIIIf Certosa fibula. Further two examples were found in Grave VIII/3 at Preloge, where a woman was supposedly buried with a child. For this grave, Goldberg mentions a small La Tène fibula, though the inventory book reveals a small bow fibula. A small spiral band bracelet was documented in Grave VII/31 at Preloge, found just beneath the turf, along with glass beads, a small fibula of the Middle La Tène scheme and a glass bracelet. An example with groups of incisions is published as part of Grave Group IV/38 from Preloge, for which Goldberg only mentions skeleton remains and parts of earrings.

Armlets of Variants **S3** and **S4** (fig. 114: 3, 5 and fig. 115)¹³²¹ were found in graves of shallow depths beneath the turf. The goods of Grave V/29 at Laščik, in which two men were buried together with four horses, include two different examples of spiral armlets (fig. 114: 3, 5). The deceased were also buried with two Negova helmets, two rectangular belt clasps, an Early La Tène sword, a mace, horse gear and bronze vessels. In Graves VII/12

¹³²⁰ Hencken 1978, Fig. 105b-d, 251d, 278e,g; Tecco Hvala/Dular/Kocuvan 2004, T. 149: 7-10.

¹³²¹ Hencken 1978, Fig. 140c, 143 l, 231a, 238b; Tecco Hvala/Dular/Kocuvan 2004, T. 44B: 6, 112A: 1.

¹³²⁰ Hencken 1978, Figs. 105b-d, 251d, 278e,g; Tecco Hvala/Dular/Kocuvan 2004, T. 149: 7-10.

¹³²¹ Hencken 1978, Figs. 140c, 143 l, 231a, 238b; Tecco Hvala/Dular/Kocuvan 2004, T. 44B: 6, 112A: 1.

sulici, šilo, nož s trnastim nastavkom za ročaj in zložljivi nož s koščeno oblogo oz. britev, medtem ko sta fibuli, speti z verižico, izgubljeni. Opisani konteksti nakazujejo, da so take narokvice nosili moški v času mlajše certoške in negovske stopnje.

and VII/19 at Preloge, a large spiral bracelet was found in combination with an iron socketed axe and a Type X Certosa fibula. The armband in Grave 13/127 from Preloge was reportedly found at the feet of a poorly preserved skeleton together with an iron knife with a narrow tang. For Grave 2/47 at Preloge, Pečnik reported it to have

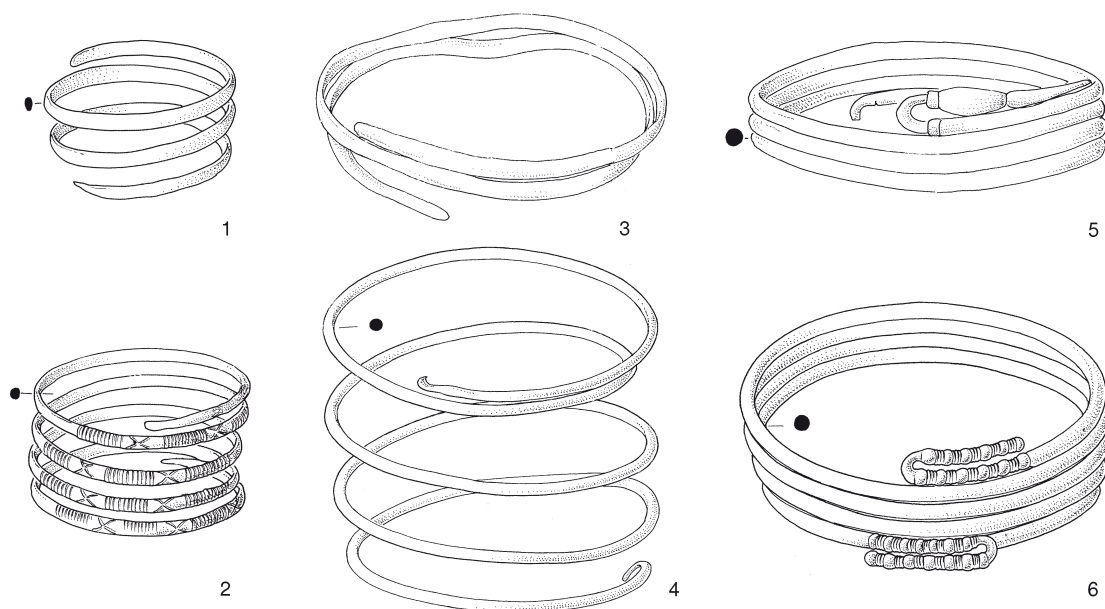

Sl. 114: Tipi bronastih spiralnih zapestnic in narokvic z Magdalenske gore. M. = 1:2.

Fig. 114: Types of spiral bronze bracelets and armlets from Magdalenska gora. Scale = 1:2.

1, 2 – najdbi brez znanih grobnih celot v NMS / finds without preserved grave group in the NMS (S1, S2);
3, 5 – Laščik, gr. V/29 (S3, S4); 4 – Preloge, gr. 13/127 (S3); 6 – Preloge, gr. 2/47 (S4).

Gom. / gr. Tum. / Gr.	Pokop / Burial rite	Spol / starost Sex / Age	Tip narokvic / Types of armrings	Št. narokvic / No. of armrings	Nanožnice / Anklets	Fibule / Fibulae	Uhani / Earrings	Steklene jagode / Glass beads	Pasne sponje / Belts	Čelade / Helmets	Žezlo / Mace	Mеч / Sword	Sekire / Axes	Sulice / Spears	Noži / Knives	Konjska oprema / Horse equipment	Lončenina / Pottery	Bronasto posodje / Bronze vessels
P VIII/3	S	F+I		2	2*	1	2	x										
P VII/31	S	I	S1	1+1*		1		x										
L V/4	S	I		2?		1												
P 13/127	S	M		1											1		1	
P VII/12	S	M		1									1					
P VII/19	S	M	S4	1?		1							1					
P 2/47	S	M		1		2?		1	1				1	2	2		x	
L V/29	S	M+M	S3+S4	1+1		?		1	2	2	1	1		4		x		4

Sl. 115: Struktura pridatkov v grobovih z bronastimi spiralnimi zapestnicami in narokvicami na Magdalenski gori. * = drugačen tip.

Fig. 115: Structure of goods in the graves with spiral bronze bracelets and armlets at Magdalenska gora. * = other type.

Razširjenost in časovni okvir. Otroške spiralne za-
pešnice različice **S1** niso ravno pogost pojav v grobiščih
dolenjske halštatske skupnosti.¹³²² V magdalenskogor-
skem grobu V/4 z Laščika nastopa skupaj s poslednjo
halštatsko izvedbo certoških fibul (vrste VIIIf), ki se je
obdržala še v latenskem obdobju.¹³²³ Latenski čas ne-
dvomno odseva tudi oprava iz groba VII/31 s Prelog, v
kateri jo zasledimo v kombinaciji s stekleno zapestnico
in fibulo srednjelatenske sheme. Latenska fibula naj bi bi-
la najdena tudi v grobu VIII/3 na Prelogah, namesto nje
pa je objavljena drobna ločna fibula. Sorodne primerke
srečamo v Dolenjskih Toplicah v grobovih iz certoške in
negovske stopnje,¹³²⁴ znane so še z nekaterih notranjskih
najdišč,¹³²⁵ z Mosta na Soči¹³²⁶ in iz okolice Čedadu.¹³²⁷

Različica **S2** z vrezanim okrasom IIIXIII je razen na
Magdalenski gori zastopana še na Vačah, v Mokronogu
in Zagorju.¹³²⁸ Na Vačah je bil par takih zapestnic najden
skupaj s kačastima fibulama,¹³²⁹ v podobnem kontekstu
jo zasledimo v Zagorju,¹³³⁰ sočasno se pojavljajo tudi na
Mostu na Soči.¹³³¹ Tak okras lahko opazimo na obroča-
stem nakitu iz estenskih grobov,¹³³² ki so datirani v sto-
pnjo Este IIIB2 po Peroniju (= Este II/III po Freyu).¹³³³

Nekoliko drugačno varianto predstavlja trakasta
spiralna zapestnica, okrašena z gostimi prečnimi vrezi,
ki je objavljena med najdbami brez grobnih celot iz
gomile VIII na Magdalenski gori.¹³³⁴ Analogijo zanjo
najdemo v Este, v grobu Villa Benvenuti 110 iz stopnje
Este IIID2 po Peroniju (= Este III-pozno po Freyu).¹³³⁵

¹³²² *Dolenjske Toplice*: Teržan 1976, T. 19: 6, 21: 14, 35: 8,
47: 6; *Libna*: Guštin 1976, T. 55: 9; *Mokronog*: neobjavljeno,
NMS inv. št. P 1753, 1848–1850, 10603; *Podzemelj*: Dular J.
1978, T. 11: 14,15; *Valična vas*: Teržan 1973, T. 10: 9,11-14;
Veliki Vinji vrh (Šmarjeta): Stare V. 1973a, T. 31: 16, 66: 15-19;
Dular A. 1991, T. 73: 22; *Vinica*: Gabrovec 1966c, T. 18: 13.

¹³²³ Teržan 1976, 371.

¹³²⁴ *Dolenjske Toplice, gr. 3/4, 5/31, 6/15*: Teržan 1976, T.
19: 6-9, 35: 6-8, 47: 1-6, 66: 12.

¹³²⁵ Guštin 1979, T. 5: 5, 23: 1-4, 66: 12, 67: 20.

¹³²⁶ Teržan/Trampuž 1973, 422 ss; Teržan/Lo Schiavo/
Trampuž-Orel 1984, T. 192B: 1, 193A: 6, 212A: 12,13, 219D:
10,11, 257C: 9, 277: 18.

¹³²⁷ Pettarin 2006, 223 s, op. 177, T. 22: 349,353, 23: 365.

¹³²⁸ *Mokronog*: neobjavljeno, NMS inv. št. P 6238, 6241;
Vače: Stare F. 1955a, T. 70: 10,11; Teržan 2003, T. 6: 5,6; *Zago-
rje*: Gabrovec 1966b, T. 5: 4,5.

¹³²⁹ Teržan 2003, 70, T. 6.

¹³³⁰ Gabrovec 1966b, T. 5: 4,5.

¹³³¹ Teržan/Lo Schiavo/Trampuž-Orel 1984, T. 216F: 5,
221D: 6, 256D: 2, 277: 16; za datacijo glej Teržan/Trampuž
1973, 428 ss.

¹³³² Chieco Bianchi/Calzavara Capuis 1985, T. 53: 16, 68:
9-13, 74: 18,19, 220: 30; Calzavara Capuis/Chieco Bianchi
2006, T. 50: 24, 55: 37-38, 61: 3, 115: 32, 185: 69.

¹³³³ Peroni et al. 1975, 127 s, Fig. 42: 7; Chieco Bianchi/
Calzavara Capuis 1985, 455 s; Calzavara Capuis/Chieco Bi-
anchi 2006, 486.

¹³³⁴ Hencken 1978, Fig. 296f.

¹³³⁵ Calzavara Capuis/Chieco Bianchi 2006, 486, T. 113: 14.

been found 2 or 3m deep in the tumulus and to have
contained a skeleton with four rings on the right upper
arm, whereby the latter was actually a single spiral armband
with four coils (*fig. 114: 6* and *fig. 115*). Other preserved
goods in this grave consist of a rectangular belt clasp, a
socketed axe, two spears, an awl, a knife with a narrow
tang and a folding knife or a razor with a bone mount,
while the two fibulae tied with a chain are now lost.
The above-described grave groups show that this type
of armbands was worn by men in the Late Certosa and
Negova phases.

Distribution and time frame. Children's spiral brace-
lets of Variant **S1** are not a common grave good in the
cemeteries of the Dolenjska Hallstatt community.¹³²² At
Magdalenska gora, Grave V/4 from Laščik revealed such
an example together with the last Hallstatt version of the
Certosa fibulae (Type VIIIf), which continued to be used
in the La Tène period.¹³²³ Also of La Tène character is
Grave Group VII/31 from Preloge, where a Variant S1
bracelet was found in combination with a glass bracelet
and a fibula of the Middle La Tène scheme. Another
La Tène fibula was reportedly found in Grave VIII/3 at
Preloge, though the publication lists a small bow fibula.
Similar examples of bracelets were found at Dolenjske
Toplice in graves of the Certosa and Negova phases,¹³²⁴
several sites in Notranjska,¹³²⁵ Most na Soči¹³²⁶ and in
the vicinity of Cividale del Friuli.¹³²⁷

Variant **S2** with an incised IIIXIII motif was
documented at Magdalenska gora, Vače, Mokronog
and Zagorje.¹³²⁸ At Vače, a pair of such bracelets was
found together with two serpentine fibulae.¹³²⁹ It was
documented in a similar context at Zagorje,¹³³⁰ of a
contemporaneous date also at Most na Soči.¹³³¹ The same
motif appears on the ring jewellery from the graves at

¹³²² *Dolenjske Toplice*: Teržan 1976, T. 19: 6, 21: 14, 35: 8,
47: 6; *Libna*: Guštin 1976, T. 55: 9; *Mokronog*: unpublished,
NMS Inv. Nos. P 1753, 1848–1850, 10603; *Podzemelj*: Dular
J. 1978, T. 11: 14,15; *Valična vas*: Teržan 1973, T. 10: 9,11-14;
Veliki Vinji vrh (Šmarjeta): Stare V. 1973a, T. 31: 16, 66: 15-19;
Dular A. 1991, T. 73: 22; *Vinica*: Gabrovec 1966c, T. 18: 13.

¹³²³ Teržan 1976, 371.

¹³²⁴ *Dolenjske Toplice, Gr. 3/4, 5/31, 6/15*: Teržan 1976, T.
19: 6-9, 35: 6-8, 47: 1-6, 66: 12.

¹³²⁵ Guštin 1979, T. 5: 5, 23: 1-4, 66: 12, 67: 20.

¹³²⁶ Teržan/Trampuž 1973, 422 ff; Teržan/Lo Schiavo/
Trampuž-Orel 1984, T. 192B: 1, 193A: 6, 212A: 12,13, 219D:
10,11, 257C: 9, 277: 18.

¹³²⁷ Pettarin 2006, 223 f, n. 177, T. 22: 349,353, 23: 365.

¹³²⁸ *Mokronog*: unpublished, NMS Inv. Nos. P 6238, 6241;
Vače: Stare F. 1955a, T. 70: 10,11; Teržan 2003, T. 6: 5,6; *Zago-
rje*: Gabrovec 1966b, T. 5: 4,5.

¹³²⁹ Teržan 2003, 70, T. 6.

¹³³⁰ Gabrovec 1966b, T. 5: 4,5.

¹³³¹ Teržan/Lo Schiavo/Trampuž-Orel 1984, T. 216F: 5,
221D: 6, 256D: 2, 277: 16; for dating see Teržan/Trampuž
1973, 428 ff.

V Dolenjskih Toplicah nastopata trakasti zapestnici, okrašeni s snopi vrezov in vmesnimi koncentričnimi krožci, skupaj s certoško fibulo vrste XIII.¹³³⁶ Podobni primerki so znani še iz Nezakcija v stopnji Istra V¹³³⁷ ter v okolici Čedadada¹³³⁸ in v Este.¹³³⁹ V tej zvezi velja omeniti še žgani pokop 159 iz grobišča Via Tiepolo v Padovi, ki je datiran na konec 6. ali na začetek 5. st. pr. n. št. Po antropoloških podatkih so bili v njem pokopani dve odrasli osebi in otrok. O prisotnosti moškega govorita železna sekira in sulična ost. Morda so mu pripadali še fragmenti večje trakaste spiralne zapestnice, okrašene s snopi vrezov, križci in punciranimi krožci, ter figuravno okrašen pas iz tanke bronaste pločevine. Na njem je med drugim upodobljena krilata in gologlava moška figura, opasana s pasom in z narokvico na levici.¹³⁴⁰ Capuis in Ruta Serafini domnevata, da so golota, obritoglavost, pas in narokvica prepoznavni znaki rokoborcev,¹³⁴¹ kar je moč opaziti tudi na upodobitvah dvoboja v situlski umetnosti, kjer nekateri gologlavi rokoborci nosijo narokvico.¹³⁴² Na Dolenjskem pa so izpričane med pridatki v moških grobovih, ki jih lahko časovno opredelimo v mlajšo certoško in zgodnjo negovsko stopnjo. Moški so takrat nosili različne tipe narokvic, med njimi tudi spiralne različice **S3** in **S4**.¹³⁴³

VOTLE ZAPESTNICE IN NANOŽNICE

Tipološke značilnosti. Nekatero zapestnico in nanožnico so bile izdelane iz tanke cevasto ukrivljene pločevine in imajo konca običajno staknjena in speta z zakovico. Različica **V1** je gladka, brez okrasa (sl. 116: 1); različica **V2** združuje primerke, ki so okrašeni s snopi vrezov (sl. 116: 3). Tudi različica **V3** (sl. 116: 4) je okrašena s snopi vrezov, vendar se od drugih primerkov razlikuje po osnovni oblikovni shemi, saj nima staknjenih koncev, temveč je večkrat zavita. Različica **V4** predstavlja primerke z iztolčenimi rebri (sl. 116: 2), različica **V5** pa je okrašena z gostimi vrezji in mestoma z mrežastim ali cikcak motivom na zaključkih (sl. 116: 5). Različica **V6** predstavlja bolj razgibano kompozicijo okrasa, sestavljeno iz pasov prečnih vrezov, cikcak linij

¹³³⁶ Teržan 1976, T. 50: 3,4.

¹³³⁷ Gabrovec/Mihovilič 1987, 313, sl. 18: 10; Mihovilič 2001, 37, T. 30: 12-20.

¹³³⁸ Pettarin 2006, T. 24: 377,380,381,384,386-389.

¹³³⁹ *Casa Mulletti Prosdocimi*, gr. 248: Chieco Bianchi/Calzavara Capuis 1985, T. 236: 12.

¹³⁴⁰ Capuis/Ruta Serafini 1996, 37 ss, Fig. 4; Gambacurta 2005, 325 ss, Fig. 7: 7, 9: 9.

¹³⁴¹ Capuis/Ruta Serafini 1996, 39, op. 6, Fig. 1, 2.

¹³⁴² Stare F. 1955a, Pril. 1; Lucke/Frey 1962, T. 33: 19b, 58: 42a, 73, Beil. 1; Turk 2005, 37 s, sl. 52, 55: 1.

¹³⁴³ *Magdalenska gora-Laščik*, gr. V/29, *Preloge*, gr. VII/12, VII/19, 2/47, 13/127; *Novo mesto-Znančeve njive*, gr. 2/2: Knez 1986, T. 74; Dular J. 2003, sl. 90: 3; *Valična vas*: Teržan 1973, T. 10: 10; *Vinkov Vrh*: Stare V. 1964-1965, T. 12: 8.

Este as well,¹³³² dated to Este IIIB2 after Peroni (= Este II/III after Frey).¹³³³

A somewhat different variant can be seen in the spiral band bracelet decorated with densely incised transverse lines published among the finds without grave groups from Tumulus VIII at Magdalenska gora.¹³³⁴ An analogy for it can be found at Este, in Grave Villa Benvenuti 110 of an Este IIID2 date after Peroni (= Este III-Late after Frey).¹³³⁵ At Dolenjske Toplice, two band bracelets, decorated with groups of incisions separated by concentric circles, were found together with a Type XIII Certosa fibula.¹³³⁶ Other similar examples are known from Nesactium from the Istra V phase,¹³³⁷ around Cividale del Friuli¹³³⁸ and at Este.¹³³⁹ Worth mentioning in connection with this variant is cremation Grave 159 from the Via Tiepolo cemetery at Padova, dated to the end of the sixth or the beginning of the fifth century BC. Anthropological analysis revealed a burial of two adults and a child, whereby the presence of a male is indicated by the iron axe and a spearhead. The male might further have been buried with a large, now fragmented spiral band bracelet decorated with stripes of incisions, crosses and ring-and-dots, as well as a belt with figural decoration made of thin sheet bronze. Depicted on the belt is a male figure with shaven heads and wings, wearing a belt and an armlet on his left arm.¹³⁴⁰ Capuis and Ruta Serafini suppose that the nudity, the shaved head, the belt and the armlet represent distinguishing marks of wrestlers.¹³⁴¹ This can also be observed in the duel scenes of the situla art, where some of the wrestlers with shaven heads also wear an armlet.¹³⁴² In the cemeteries of Dolenjska, armlets were found in male graves from the Late Certosa and Early Negova phases. Apart from Variants **S3** and **S4**, men also wore other types of armlets at that time.¹³⁴³

¹³³² Chieco Bianchi/Calzavara Capuis 1985, T. 53: 16, 68: 9-13, 74: 18,19, 220: 30; Calzavara Capuis/Chieco Bianchi 2006, T. 50: 24, 55: 37-38, 61: 3, 115: 32, 185: 69.

¹³³³ Peroni *et al.* 1975, 127 f, Fig. 42: 7; Chieco Bianchi/Calzavara Capuis 1985, 455 f; Calzavara Capuis/Chieco Bianchi 2006, 486.

¹³³⁴ Hencken 1978, Fig. 296f.

¹³³⁵ Calzavara Capuis/Chieco Bianchi 2006, 486, T. 113: 14.

¹³³⁶ Teržan 1976, T. 50: 3,4.

¹³³⁷ Gabrovec/Mihovilič 1987, 313, fig. 18: 10; Mihovilič 2001, 37, T. 30: 12-20.

¹³³⁸ Pettarin 2006, T. 24: 377,380,381,384,386-389.

¹³³⁹ *Casa Mulletti Prosdocimi*, Gr. 248: Chieco Bianchi/Calzavara Capuis 1985, T. 236: 12.

¹³⁴⁰ Capuis/Ruta Serafini 1996, 37 ff, Fig. 4; Gambacurta 2005, 325 ff, Figs. 7: 7, 9: 9.

¹³⁴¹ Capuis/Ruta Serafini 1996, 39, n. 6, Figs. 1, 2.

¹³⁴² Stare F. 1955a, Beil. 1; Lucke/Frey 1962, T. 33: 19b, 58: 42a, 73, Beil. 1; Turk 2005, 37 f, figs. 52, 55: 1.

¹³⁴³ *Magdalenska gora-Laščik*, Gr. V/29, *Preloge*, Gr. VII/12, VII/19, 2/47, 13/127; *Novo mesto-Znančeve njive*, Gr. 2/2: Knez 1986, T. 74; Dular J. 2003, Abb. 90: 3; *Valična vas*: Teržan 1973, T. 10: 10; *Vinkov Vrh*: Stare V. 1964-1965, T. 12: 8.

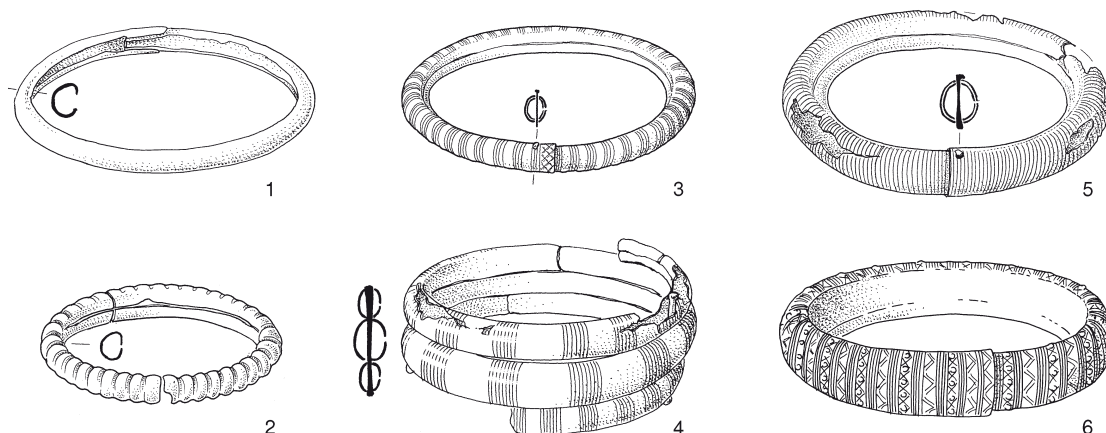

Sl. 116: Tipi bronastih votlih zapestnic in nanožnic z Magdalenske gore. M. = 1:2.

Fig. 116: Types of hollow bronze bracelets and anklets from Magdalenska gora. Scale = 1:2.

- 1 – Preloge, gr. X/37 (V1); 2 – Preloge, gr. 13/163 (V4); 3 – Preloge, gr. 13/36 (V2);
4 – najdba brez znane grobne celote v NMS / find without preserved grave group in the NMS (V3);
5 – Preloge, gr. 13/57 (V5); 6 – Preloge, gr. VIII/a (V6).

ali mrežastim motivom ter z iztolčenimi bunčicami (sl. 116: 6). V okrasu se torej ponovijo vse pglavitne stilne prvine, ki se pojavljajo že na polno ulitih obročih.

Lega in kontekst. Neornamentirana votla zapestnica različice V1 (sl. 116: 1 in sl. 117) je objavljena v sklopu grobne celote X/37 s Prelog in je edini tak primerek z Magdalenske gore. Po Goldbergovih navedbah naj bi bila najdena na zapestju desne roke slabo ohranjenega okostja, ki je imelo še vozlasto ovratnico in jantarne jagode.¹³⁴⁴ Po teh pridatkih sodeč je bila v njem pokopana ženska, kar se ne sklada z ugotovitvami Angela, ki je kostne ostanke iz tega groba opredelil kot moškega zrelih let.¹³⁴⁵

Bolj pogoste so zapestnice različice V2, ki so okrašene s snopi vrezov (sl. 116: 3 in sl. 117).¹³⁴⁶ Pokojnica v grobu VII/25 na Prelogah je imela na vsaki roki po eno zapestnico različice V2, na gležnjih pa par votlih nanožnic različice V5. Ženska, pokopana v grobu X/72, pa jo je nosila na levem zapestju, poleg tega je imela na vsaki roki po en masiven narebren obroč, na prsih kačasto fibulo s krilci in okoli vratu jantarno ogrlico. Na desni strani prsnega koša je ležalo še dvojje votlih narokvic in čolničasta fibula, pri kolenih pa debele jantarne jagode in koščki zlate folije. Še bogatejši nakit je imela pokojnica v grobu 13/117 s Prelog, ki je merila 185 cm; ob njenem desnemu kolenu so menda našli štiri zapestnice, dve nanožnici in deset lepih valjastih uhanov, na vsaki roki je imela po eno votlo zapestnico, na nogah pa po eno votlo nanožnico. Krasile so jo še ogrlice iz raznobarnih

HOLLOW BRACELETS AND ANKLETS

Typological characteristics. Bracelets and anklets made of thin sheet metal bent to form a tube usually have one end that fits inside the other and bound by a rivet. Of those, Variant V1 is plain (fig. 116: 1), Variant V2 decorated with stripes of incisions (fig. 116: 3), Variant V3 (fig. 116: 4) is coiled and decorated with stripes of incisions, Variant V4 bears embossed ribs (fig. 116: 2), Variant V5 has densely incised lines and sometimes also reticular or zigzag motifs on the ends (fig. 116: 5), while Variant V6 shows a more varied decorative composition consisting of transverse incisions stripes, zigzag or reticular motifs as well as embossed dots (fig. 116: 6). The decoration of the hollow ring jewellery thus shows the same stylistic elements as observed on the solid cast examples.

Position and context. Un decorated hollow bracelet of Variant V1 (fig. 116: 1 and fig. 117) is published as part of Grave Group X/37 from Preloge and represents the only such example from Magdalenska gora. According to Goldberg, it was found on the right wrist of a poorly preserved skeleton, which also had a knobbed torque and amber beads.¹³⁴⁴ These grave goods indicate a female, though this is inconsistent with Angel's findings, who ascribed the bone remains to a mature male.¹³⁴⁵

Appearing more frequently are bracelets of Variant V2, decorated with stripes of incisions (fig. 116: 3 and fig. 117).¹³⁴⁶ One such bracelet was found on each of the arms

¹³⁴⁴ Hencken 1978, 72, Fig. 328c.

¹³⁴⁵ Angel 1968, 95, Fig. 9.

¹³⁴⁶ Hencken 1978, Fig. 245b,c, 357c; Tecco Hvala/Dular/Kocuvan 2004, T. 59B: 2, 76: 17-20, 106: 55, 138: 4,5, 151: 7,8,9.

¹³⁴⁴ Hencken 1978, 72, Fig. 328c.

¹³⁴⁵ Angel 1968, 95, Fig. 9.

¹³⁴⁶ Hencken 1978, Figs. 245b,c, 357c; Tecco Hvala/Dular/Kocuvan 2004, T. 59B: 2, 76: 17-20, 106: 55, 138: 4,5, 151: 7,8,9.

Gom. / Gr. Tum. / Gr.	Pokop / Burial rite	Spol / Starost Sex / Age	Tip zapestnic / nanožnic Types of bracelets / anklets	Št. zapestnic / No. of bracelets	Št. nanožnic / No. of anklets	Fibule / Fibulae	Igle / Pins	Uhani / Earrings	Ovratnice / Torques	Steklene jagode / Glass beads	Jantar / Amber	Scepter / Sceptre	Au nakit / Au jewellery	Prstan / Finger-ring	Pasne sponje / Belts	Čelada / Helmet	Sekire / Axes	Sulice / Spears	Puščice / Arrows	Noži / Knives	Raženj / Spit	Brus / Whetstone	Lončenina / Pottery	Vijčki / Spindle whorls	Koščen tul / Bone tube	Bronasto posodje / Bronze vessels
P X/37	S	F	V1	1					1		x															
P 13/163	C	I?	V4	4+8*	23*	3				x	x												x			
P 2/15	S	F	V4	2	2*	1																	1	4		
P X/72	S	F	V2+V4	1+2*	2?	2					x		x													
P VII/25	S	F		2	2			1		1	x												2			
P 13/36	S	F+M?	V2+V5	4	2	2		2		x	x	1			1					1		1				
P 13/117	S	F		4+2*	4	4		10		x	x		x													
P VII/1	C?	F	V3+V5	1+1	1?	1				x																
P VI/33a	?	I		1+2*		1																				
P 2/65	S	I		2*	2	1		x		x													1			
P X/50	S	F		1+2*		2	1																			
P 13/37a	S	I		1						2																
P 13/22	S	F		1							x												1			
P 13/2	S	F		1						x	x															
P VII/18	S	F		1				1		x	x															
P VII/37	S	F		1				1			x															
P IV/48	?	F		2				3			x															
P 13/160	S	F		2				4			x												1			
P 13/57	S	F		2							x												1			
P 2/20	?	F		2																						
P VI/8	S	F		3		1					x															
P 13/87	S	F		2		1		2		x	x															
P 2/63	S	F	V5	2		1		x			x			1												
L V/36	S	F		2		1		2			x															
P VII/27	S	F		2		1				x													1			
P 2/66	S	I		2		1		x		x													1			
P VII/38	S	F		2	2	1					x															
L V/37	S	F		2	2	1				x	x															
P 2/38	S	M		2						1					1	1	1		x	1	1	1	1		1	
P 13/26	S?	M?		1											1					1			1			
P 13/1	S	?		2	2	1		2										1					1			
P 13/159	S	F		2	2			4												1			1			
P IV/31	?	F?		2	2																			2		
P 13/97	S	F		2	2			2		x	x	1											1			
P 2/p	S	F		2	1?						x												1		1	
P VIII/4	S	F?		2		1			1	x		1											1			
P 2/a	S	F		4		8	2	2		x	x		x										1		2	
L V/2	S	F+I	V5+V6	2+2		1	2	4-6		x	x															
P X/34-35	S	F+A?	V6	2		1					x															
VIII/10-11	S	F+A?	V6	1		2																				

Sl. 117: Struktura pridatkov v grobovih z bronastimi votlimi zapestnicami in nanožnicami na Magdalenski gori.

* = drugačen tip.

Fig. 117: Structure of goods in the graves with hollow bronze bracelets and anklets at Magdalenska gora. * = other type.

steklenih in jantarnih jagod, zlata folija in štiri drobne ločne fibule. V grobu 13/36 iz iste gomile je bil najden komplet štirih votlih zapestnic in par enakih nanožnic ter dve certoški fibuli vrste V, razen tega še dva valjasta uhana, steklene jagode vseh vrst, sceptor in železna rombična pasna spona.

Zapestni obroček različice V3 (*sl. 116: 4 in sl. 117*)¹³⁴⁷ je bil menda najden na tanki plasti žganine z ostanki sežganih kosti in brez žare v grobu VII/1 na Prelogah, ki je vseboval še primerke zapestnic in nanožnic različice V5, niz steklenih jagod ter fibulo, ki se ni ohranila.

Z nekaj več primerki je zastopana različica V4 (*sl. 116: 2 in sl. 117*).¹³⁴⁸ V žganem grobu 13/163 na Prelogah jo srečamo skupaj z gladkimi masivnimi bronastimi zapestnicami in nanožnicami ter fibulami z oblogo. Primerek iz groba X/72 na Prelogah pa predstavlja nanožnico, ki nastopa v kombinaciji z masivnima narebrenima zapestnicama ter s čolničasto in kačasto fibulo. V grobnem sestavu 2/15 s Prelog zasledimo votlo zapestnico različice V4 skupaj z narebrenima masivnima nanožnicama in s certoško fibulo vrste V.

Najbolj tipično izvedbo votlega obročastega nakita predstavlja različica V5, ki je okrašena z gostimi prečnimi vrezi (*sl. 116: 5*);¹³⁴⁹ oprave, v katerih se pojavlja, bi lahko razdelili na več skupin (*sl. 117*).

Skromnejšo žensko nošo predstavljajo sestavi z eno ali dvema zapestnicama in brez fibul, včasih so zraven še ogrlice in valjasti uhani.¹³⁵⁰ V grobovih 13/2 in 13/22 iz iste gomile je bila taka zapestnica najdena na desnici okostja, na levisi pa pri pokojnici v grobu X/50 s Prelog, ki je imela na isti roki še dve narebreni polno uliti narokvici. Nekatere predstavnice so nosile na vsaki roki po eno votlo zapestnico. V to skupino bi lahko uvrstili tudi otroški pokop 13/37a s Prelog.

V drugo skupino spadajo ženske in otroške oprave, h katerim je bila dodana ena fibula (*sl. 117*).¹³⁵¹ Gre za fibulo z mrežastim okrasom na loku ali pa mlajše forme certoških fibul, tj. vrst VIIe, g in XIII, ter vzhodnoalpske živalske fibule. Kakšni fibuli sta bili najdeni v grobovih 2/63 in 2/66 s Prelog, ni znano, ker sta izgubljeni.

of the female in Grave VII/25 at Preloge, who also wore a pair of hollow anklets of Variant V5. The female buried in Grave X/72 wore it on her left wrist, together with a solid ribbed ring on each of her arms, a serpentine fibula with wings on her chest and an amber necklace around her neck. Lying on the left side of her chest were two hollow armllets and a boat fibula, while large amber beads and pieces of gold foil were found at her knees. Even richer jewellery was found on the 185cm tall female buried in Grave 13/117 at Preloge; it consisted of four bracelets, two anklets and ten beautiful cylindrical earrings at her right knee, a hollow bracelet on each of her arms and a hollow anklet on each of her legs. She was further adorned by necklaces of multicoloured glass and amber beads, gold foil and four small bow fibulae. Grave 13/36 from the same tumulus yielded a set of four hollow bracelets and a pair of anklets of the same kind, two Type V Certosa fibulae, two cylindrical earrings, various types of glass beads, a sceptor and an iron rhombic belt clasp.

A bracelet of Variant V3 (*fig. 116: 4 and fig. 117*)¹³⁴⁷ was reportedly found on a thin layer of burnt remains mixed with cremated bone in Grave VII/1 at Preloge, which further contained bracelets and anklets of Variant V5, a set of glass beads and a fibula, the latter now lost.

Represented with more examples is Variant V4 (*fig. 116: 2 and fig. 117*).¹³⁴⁸ One was found in cremation Grave 13/163 at Preloge together with plain solid bronze bracelets and anklets as well as fibulae with overlay. The example from Grave X/72 at Preloge is an anklet; it was found in combination with two solid ribbed bracelets as well as a boat and a serpentine fibula. Grave 2/15 at Preloge contained a hollow bracelet of Variant V4, two ribbed solid anklets and a Type V Certosa fibula.

Of all the hollow ring jewellery, the most typical is that of Variant V5, decorated with dense transverse incisions (*fig. 116: 5*),¹³⁴⁹ which formed part of several groups of costume (*fig. 117*).

A simple costume includes one or two bracelets, sometimes necklaces and cylindrical earrings, but no fibulae.¹³⁵⁰ Graves 13/2 and 13/22 at Preloge, for example, revealed one such bracelet on the right arm of the skeleton. On the left arm it was found on a female skeleton in Grave X/50 at Preloge, which also had two ribbed solid cast armllets on the same arm. Several female representatives wore one hollow bracelet on each of the

¹³⁴⁷ Hencken 1978, Fig. 220d.

¹³⁴⁸ Hencken 1978, Fig. 23a, 81, 222, 357g; Tecco Hvala/Dular/Kocuvan 2004, T. 28A: 2, 124: 18-21.

¹³⁴⁹ Hencken 1978, Fig. 23b, 32a,d, 59c,d, 71d,e,f, 83l, 89c, 182c,d, 208a, 220a,b, 237c, 245e, 247c, 256a, 257c, 278e, 294b, 329b, 339g, 366b; Tecco Hvala/Dular/Kocuvan 2004, T. 7: 3,4, 14C: 1,2, 28C: 1, 35: 11,12, 54C: 4,5, 55B: 5, 58A: 9, 59B: 1, 66A: 4-6, 66B: 3, 71B: 2, 72C: 1, 75D: 3, 76: 21,22, 86B: 2,3, 95A: 20,21, 100: 17,18, 106: 58-65, 113A: 1,2, 118: 14,15, 120B: 8,9, 122A: 5,6, 7,8,13,14, 128: 34-37, 151: 3-6,10-15.

¹³⁵⁰ Preloge, gr. IV/48, VII/18, VII/37, 2/20, 13/2, 13/22, 13/57, 13/160.

¹³⁵¹ Laščik, gr. V/36, V/37, Preloge, gr. 2/63, 2/65, 2/66, 13/1, 13/87, VI/8, VI/33a, VII/27, VII/38.

¹³⁴⁷ Hencken 1978, Fig. 220d.

¹³⁴⁸ Hencken 1978, Figs. 23a, 81, 222, 357g; Tecco Hvala/Dular/Kocuvan 2004, T. 28A: 2, 124: 18-21.

¹³⁴⁹ Hencken 1978, Figs. 23b, 32a,d, 59c,d, 71d,e,f, 83l, 89c, 182c,d, 208a, 220a,b, 237c, 245e, 247c, 256a, 257c, 278e, 294b, 329b, 339g, 366b; Tecco Hvala/Dular/Kocuvan 2004, T. 7: 3,4, 14C: 1,2, 28C: 1, 35: 11,12, 54C: 4,5, 55B: 5, 58A: 9, 59B: 1, 66A: 4-6, 66B: 3, 71B: 2, 72C: 1, 75D: 3, 76: 21,22, 86B: 2,3, 95A: 20,21, 100: 17,18, 106: 58-65, 113A: 1,2, 118: 14,15, 120B: 8,9, 122A: 5,6, 7,8,13,14, 128: 34-37, 151: 3-6,10-15.

¹³⁵⁰ Preloge, Gr. IV/48, VII/18, VII/37, 2/20, 13/2, 13/22, 13/57, 13/160.

Tovrstni obročast nakit zasledimo tudi v najboga-tejših ženskih opravah iz certoške stopnje (*sl. 117*).¹³⁵² V grobu 2/a, ki se je nahajal na zahodni strani gomile in 4 m globoko, je bilo odkrito okostje bojda izjemno velike ženske. Od glave do peta je bilo prekrito z bronastimi našitki in s steklenimi jagodicami vseh vrst, k nogam sta bili položeni dve bronasti okrašeni situli ter črna glinasta posoda, v smeri od nog proti glavi je ležalo osem drobnih fibul, na rokah pa je imela dve lepi votli zapestnici. Krasili so jo še debela jantarna ogrlica in dva pozlačena trakasta uhana. Grobna celota žal ni ohranjena, med najdbami je bilo moč prepoznati le nekaj najznačilnejših kosov. V isti gomili je bila pokopana še ena pripadnica z razkošno opravo (2/p), h kateri sta spadali nenavadno debeli in fino izdelani votli zapestnici, ena nanožnica in jantarna ogrlica; pridani ji je bil unikaten bronast ciborij, pokrit s figuralno okrašenim pokrovom. Tudi to grobno celoto smo na podlagi zapiskov lahko samo delno rekonstruirali.

Votle narokvice prav tako zasledimo v nekaterih grobovih z orožjem.¹³⁵³ Pokojnik v grobu 2/38 s Prelog je bil opremljen z dvogrebenasto čelado, tulasto sekiro, nožem in puščičnimi ostmi, imel je še bronasto pravokotno spono in raženj ter dve taki narokvici. Grob 13/1 s Prelog pa je vseboval par votlih zapestnic in nanožnic, razen tega še železno sulično ost in fragment samostrelne fibule s pritrjeno ploščico na loku.

Zapestnice različice **V6**, ki imajo bolj razgiban okras, so redke (*sl. 116: 6 in sl. 117*),¹³⁵⁴ pojavljajo pa se v okviru dvojnih pokopov. V grobu X/34–35 na Prelogah sta bili pokopani domnevno dve odrasli ženski, druga vrh druge (*sl. 34: B*); ob levi rami vrhnjega okostja je ležal par votlih zapestnic, pripadali sta mu še kačasta fibula s sedlastim lokom in jantarna ogrlica, medtem ko je bilo spodnje okostje brez pridatkov. Enaka situacija je opisana tudi v zvezi s pokopom VIII/10–11 na Prelogah, kjer naj bi pri zgornjem okostju našli zdrobljeno votlo zapestnico in dve certoški fibuli, spodnje pa ni imelo ničesar. Ženska, pokopana v grobu V/2 na Laščiku, je imela na vsaki roki po en tak obroč ter en par zapestnic pri desnem komolcu. K njeni opravi so spadali tudi štirje ali šest valjastih uhanov, ogrlica, certoška fibula in igla s kroglasto glavo, medtem ko se je domnevno otroški nakit nahajal pri njenih nogah skupaj z jelenjimi koščicami.

Precej drugačni sta votli zapestnici iz groba 13/131 s Prelog, ki se od vseh drugih primerkov razlikujeta po ornamentu in debelini (*sl. 118: 14*). V kompoziciji okrasa sta podobni polno ulitim zakovičnim zapestnicam iz Dolenjskih Toplic, ki so datirane v negovsko stopnjo.¹³⁵⁵ Tudi stratigrafska lega magdalenskogorskega groba kaže, da gre za mlajši pokop v gomilo, saj se je nahajal le pičlih 40 cm pod rušo.

arms. This costume group also includes a child buried in Grave 13/37a.

The second costume group is constituted by women's and children's grave groups that include one fibula (*fig. 117*).¹³⁵¹ The latter is either a fibula with reticular decoration on the bow, late forms of Certosa fibulae, namely Types VIIe, g and XIII, as well as East Alpine animal-headed fibulae, while the fibulae found in Grave Groups 2/63 and 2/66 from Preloge are now lost and their type unknown.

Ring jewellery of Variant V4 was also documented in the richest female graves from the Certosa phase (*fig. 117*).¹³⁵² Grave 2/a, found on the western side of the tumulus at a depth of 4m, revealed a skeleton of a reportedly extremely tall woman. The skeleton was covered from feet to toe with bronze trimmings and small glass beads once sewn onto her dress. Furthermore, two decorated bronze situlae and a black clay vessel were found at her feet, eight small fibulae were laid along the length of the skeleton, two beautiful hollow bracelets adorned her arms, while also found with her were an amber necklace and two gilded band earrings or foil. This grave group has not been preserved as a whole, only some of the finds could be identified. Buried in the same tumulus was another richly accoutred female (Grave 2/p), her costume consisting of two unusually thick and finely made hollow bracelets, an anklet and an amber necklace. She was also buried with a unique footed bowl made of bronze, covered with a lid bearing figural decoration. This grave group could, on the basis of notes, also be reconstructed only in part.

Hollow bracelets were found in several graves with weapons as well.¹³⁵³ The deceased in Grave 2/38 at Preloge was buried with a double-crested helmet, a socketed axe, a knife and arrowheads, a bronze rectangular belt clasp, a spit and two hollow armlets. Grave 13/1 from Preloge, on the other hand, revealed a pair of hollow bracelets and anklets, an iron spearhead and a fragment of a crossbow fibula with a plate attached to the bow.

Bracelets of Variant **V6**, with a more varied decoration, are rare finds (*fig. 116: 6 and fig. 117*)¹³⁵⁴ and appear in double burials. Grave X/34–35 at Preloge supposedly contained two adult females, one on top of the other (*fig. 34: B*). The upper skeleton had a pair of hollow bracelets at the left shoulder, as well as a serpentine fibula with a saddle-shaped bow and an amber necklace, while the lower skeleton was without grave goods. The same situation was described in Grave VIII/10–11 at Preloge, where a crushed hollow bracelet and two Certosa fibulae were found with the upper skeleton, while the skeleton below had no grave goods. The woman buried in Grave V/2 at Laščik had one Variant 6 ring on each of her arms

¹³⁵² Preloge, gr. 2/a, 2/p, 13/117, VIII/4.

¹³⁵³ Tecco Hvala/Dular/Kocuvan 2004, T. 35: 11,12, 66A: 6.

¹³⁵⁴ Hencken 1978, Fig. 103m, 284d, 294a, 326d.

¹³⁵⁵ Teržan 1976, 388, T. 81: 9,11.

¹³⁵¹ Laščik, Gr. V/36, V/37, Preloge, Gr. 2/63, 2/65, 2/66, 13/1, 13/87, VI/8, VI/33a, VII/27, VII/38.

¹³⁵² Preloge, Gr. 2/a, 2/p, 13/117, VIII/4.

¹³⁵³ Tecco Hvala/Dular/Kocuvan 2004, T. 35: 11,12, 66A: 6.

¹³⁵⁴ Hencken 1978, Figs. 103m, 284d, 294a, 326d.

Razširjenost in časovni okvir. Zapestnice, izdelane iz cevasto ukrivljene pločevine, srečamo že v žarnogrobiščnih kontekstih, v glavnem pa gre za neokrašene primerke.¹³⁵⁶ Neornamentirana različica **VI** se na teritoriju dolenske skupnosti pojavlja tudi na nekaterih železnodobnih najdiščih,¹³⁵⁷ vendar konteksti večinoma niso ohranjeni. Na Magdalenski gori nastopa v grobu X/37 s Prelog skupaj z vozlasto ovratnico različice D2, kar bi govorilo za čas stopnje Stična 2. Nekoliko drugačni gladki votli nanožnici, ki imata pare luknjic za obeske, sta bili najdeni na Brezju v grobu 1/72 skupaj s trortasto fibulo vrste VI po Ogrinovi, ki je prav tako značilna za stopnjo Stična 2.

Votle zapestnice različice V2 in V3 je obravnavala že Teržanova in ugotavljala lokalne posebnosti v izdelavi takšnega nakita.¹³⁵⁸ Različico **V2** z dotikajočimi oz. staknjenimi konci je Parzinger označil za varianto Dolenjske Toplice,¹³⁵⁹ kjer je poleg Velikega Vinjega vrha (Šmarjete) najštevilneje zastopana.¹³⁶⁰ Njihov vznik v stopnji Stična nakazuje grob z Libne z veliko čolničasto fibulo.¹³⁶¹ Med zgodnejše kontekste sodita tudi grob X/72 z Magdalenske gore, kjer nastopa skupaj s čolničasto in kačasto fibulo, ter grob 3 iz Volčjih Njiv, ki pripada prvi generaciji pokopov v gomilo v času stopnje kačastih fibul.¹³⁶² Sicer jih pogosteje srečujemo v kombinacijah s certoškimi fibulami.¹³⁶³

V mlajšem halštatskem obdobju so se na Dolenjskem nosile tudi spiralne votle zapestnice različice **V3**.¹³⁶⁴ Sorodni primerki z notranjskih najdišč so dati-

¹³⁵⁶ Glej npr. Gabrovec 1973, T. 4: 1,3, 11: 3,4; Knez 1967, T. 1: 8.

¹³⁵⁷ *Brezje*: Kromer 1959a, T. 8: 10; *Podzemelj*: Dular J. 1978, T. 11: 24; *Velike Malence*: Stare V. 1960–1961, T. 15: 10; *Veliki Vinji vrh (Šmarjeta)*: Stare V. 1973a, T. 61: 15.

¹³⁵⁸ Teržan 1974, 39 s, sl. 4.

¹³⁵⁹ Parzinger/Nekvasil/Barth 1995, 34, 264, Abb. 13.2.

¹³⁶⁰ *Brezje*: Kromer 1959a, T. 42: 9, 52: 3; *Brusnice*: Teržan 1974, T. 10: 12,13; *Dolenjske Toplice*: Teržan 1976, T. 1: 10, 7: 4, 9: 4,5, 10: 4, 17: 2-4, 50: 13, 65: 5; *Libna*: Guštin 1976, T. 13: 3, 18: 13,16, 31: 3; *Novo mesto*: Knez 1986, T. 20: 15, 21: 7, 28: 3; id. 1993, T. 23: 1,2; *Podzemelj*: Dular J. 1978, T. 11: 23; *Stična*: Wells 1981, Fig. 37b, 58a, 94e, 176c; Dular J. 2003, T. 1: 7; Gabrovec et al. 2006, T. 186: 43; *Vače*: Stare F. 1955a, T. 69: 10,11 in neobjavljeni primerki, NHMW inv. št. 7910, 7913, 7974; *Velike Malence*: Stare V. 1960–1961, T. 16: 8; *Veliki Vinji vrh (Šmarjeta)*: Stare V. 1973a, T. 28: 1-3,5-7,9,10,13,16, 61: 2,14; Dular A. 1991, T. 13: 21,22, 28: 20,21; *Vinkov vrh*: Stare V. 1964–1965, T. 13: 7; *Volčje Njive*: Gabrovec 1956, T. 3: 1; Teržan 1976, 384, sl. 54: 1-4.

¹³⁶¹ Müller-Karpe 1953, Abb. 1.

¹³⁶² Teržan 1976, 384, sl. 53, 54: 1-4.

¹³⁶³ *Magdalenska gora-Preloge, gr. 13/36, 13/117; Brezje, gr. 13/7*: Kromer 1959a, 68, T. 52: 3-5; *Dolenjske Toplice, gr. 2/19*: Teržan 1976, T. 9: 4-11; *Libna, Glogovškova gomila 2/7*: Guštin 1976, 41, T. 31: 2,3; *Novo mesto-Znančeve njive, gr. 2/19*: Knez 1986, T. 21, 22: 1,2, 70.

¹³⁶⁴ *Libna*: Guštin 1976, T. 62: 2, 70: 18; *Stična*: Wells

and a pair of bracelets beside the right elbow. Her costume further included four or six cylindrical earrings, a necklace, a Certosa fibula and a spherical-headed pin, while the supposedly children's jewellery was found at her feet together with red deer bones.

The hollow bracelets from Grave 13/131 at Preloge differ from all other known examples in both decoration and thickness (*fig. 118: 14*). The composition of the decoration is similar to that observed on the solid cast and riveted bracelets from Dolenjske Toplice, dated to the Negova phase.¹³⁵⁵ Also telling in connection with Grave 13/131 at Magdalenska gora is its stratigraphic position, since it was found in the tumulus only 40cm beneath the turf.

Distribution and time frame. Bracelets of tubular bronze sheet already formed part of Urnfield culture contexts, but these were mainly undecorated.¹³⁵⁶ The undecorated Variant **VI** also appeared at some Iron Age sites on the territory of the Dolenjska community,¹³⁵⁷ but their contexts have, for the most part, not been preserved. At Magdalenska gora, one example was found in Grave X/37 at Preloge together with a knobbed torque of Variant D2, which indicates a Stična 2 date. Somewhat different are the plain hollow anklets with pairs of holes for pendants, found at Brezje, in Grave 1/72, together with a three-knobbed fibula of Type VI after Ogrin, which is also characteristic of the Stična 2 phase.

Hollow bracelets of Variants V2 and V3 were studied already by Teržan, who observed local features in the production of such jewellery.¹³⁵⁸ Variant **V2** with either touching ends or one end fitting inside the other was marked by Parzinger as the Dolenjske Toplice variant,¹³⁵⁹ after a site that revealed the most numerous examples; another site with a great number of such finds being Veliki Vinji vrh (Šmarjeta).¹³⁶⁰ The form was conceived in the Stična phase, which is indicated

¹³⁵⁵ Teržan 1976, 388, T. 81: 9,11.

¹³⁵⁶ See, for example, Gabrovec 1973, T. 4: 1,3, 11: 3,4; Knez 1967, T. 1: 8.

¹³⁵⁷ *Brezje*: Kromer 1959a, T. 8: 10; *Podzemelj*: Dular J. 1978, T. 11: 24; *Velike Malence*: Stare V. 1960–1961, T. 15: 10; *Veliki Vinji vrh (Šmarjeta)*: Stare V. 1973a, T. 61: 15.

¹³⁵⁸ Teržan 1974, 39 f, Abb. 4.

¹³⁵⁹ Parzinger/Nekvasil/Barth 1995, 34, 264, Abb. 13.2.

¹³⁶⁰ *Brezje*: Kromer 1959a, T. 42: 9, 52: 3; *Brusnice*: Teržan 1974, T. 10: 12,13; *Dolenjske Toplice*: Teržan 1976, T. 1: 10, 7: 4, 9: 4,5, 10: 4, 17: 2-4, 50: 13, 65: 5; *Libna*: Guštin 1976, T. 13: 3, 18: 13,16, 31: 3; *Novo mesto*: Knez 1986, T. 20: 15, 21: 7, 28: 3; id. 1993, T. 23: 1,2; *Podzemelj*: Dular J. 1978, T. 11: 23; *Stična*: Wells 1981, Figs. 37b, 58a, 94e, 176c; Dular J. 2003, T. 1: 7; Gabrovec et al. 2006, T. 186: 43; *Vače*: Stare F. 1955a, T. 69: 10,11 and unpublished examples, NHMW Inv. Nos. 7910, 7913, 7974; *Velike Malence*: Stare V. 1960–1961, T. 16: 8; *Veliki Vinji vrh (Šmarjeta)*: Stare V. 1973a, T. 28: 1-3,5-7,9,10,13,16, 61: 2,14; Dular A. 1991, T. 13: 21,22, 28: 20,21; *Vinkov vrh*: Stare V. 1964–1965, T. 13: 7; *Volčje Njive*: Gabrovec 1956, T. 3: 1; Teržan 1976, 384, Abb. 54: 1-4.

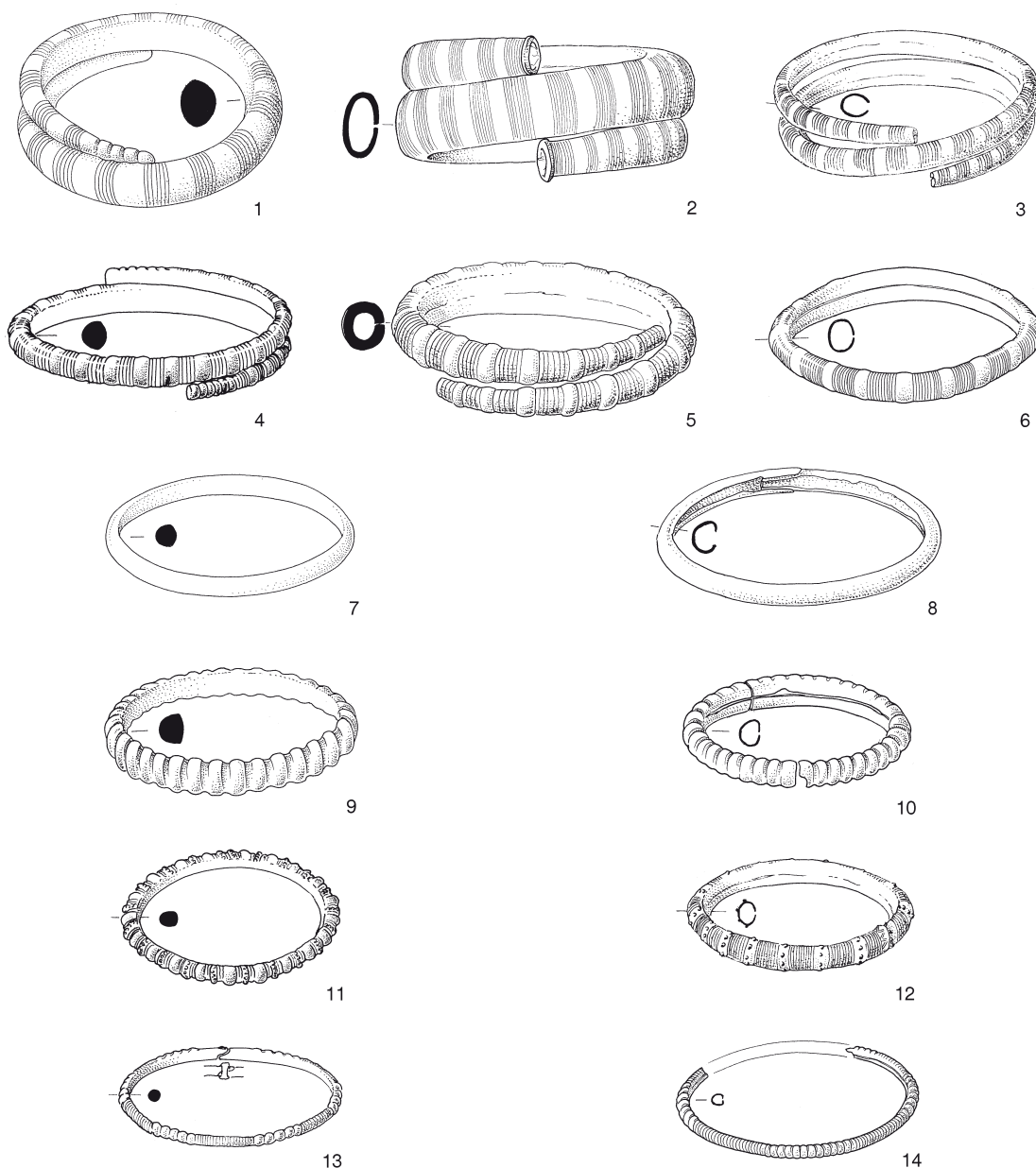

Sl. 118: Primerjava polno ulitih in votlih primerkov bronastega obročastega nakita.

Fig. 118: Comparison of solid and hollow examples of bronze ring jewellery.

1, 3, 4, 6–11, 14 – *Magdalenska gora* (Hencken 1978, Fig. 220d, 328c;

Tecco Hvala/Dular/Kocuvan 2004, T. 59B: 2, 78D: 4, 99B: 1, 115B: 6, 124: 19, 113A: 1, 150: 4);

2 – *Stična* (Wells 1981, Fig. 182g); 5 – *Vače* (Stare F. 1955a, T. 68: 4); 12, 13 – *Dolenjske Toplice* (Teržan 1976, 58: 7, 81: 9).

rani v stopnjo Notranjska V (= stopnja certoških fibul na Dolenjskem).¹³⁶⁵

1981, Fig. 42a; Gabrovec et al. 2006, T. 186: 45, 193: 5,6; *Vače*: Stare F. 1955a, T. 69: 9 in neobjavljeni primerki, NHMW inv. št. 3594, 14189; *Valična vas*: Teržan 1973, 682, T. 6: 1-3; *Veliki Vinji vrh (Šmarjeta)*: Stare V. 1973a, T. 28: 14, 33: 2; *Vinkov vrh*: Stare V. 1964–1965, T. 13: 3,6.

¹³⁶⁵ Guštin 1973, 476, sl. 2: 45; id. 1979, T. 23: 25-31, 27: 8, 67: 10,11.

by the grave from Libna with a large boat fibula.¹³⁶¹

Among the early contexts is also Grave X/72 from *Magdalenska gora*, where the variant appears together with a boat and a serpentine fibula, and Grave 3 from *Volčje Njive*, which belongs to the first generation of tumulus burials in the Serpentine Fibulae phase.¹³⁶²

¹³⁶¹ Müller-Karpe 1953, Abb. 1.

¹³⁶² Teržan 1976, 384, Abb. 53, 54: 1-4.

Tipično sestavino ženske noše dolenske halštatske skupnosti predstavljajo votle zapestnice in nanožnice različic V4¹³⁶⁶ in V5.¹³⁶⁷ Parzinger je narebreno različico V4 poimenoval za varianto Brezje,¹³⁶⁸ primerke z gostimi vrezi pa za varianto Magdalenska gora.¹³⁶⁹ Tak nakit se pojavi že v stopnji Stična 2, v kontekstih iz stopnje kačastih fibul le poredko naletimo nanj, najbolj se je razmahnil v certoški stopnji, potem pa se je v negovski stopnji postopno umaknil iz uporabe.

Različico V6 srečamo na raznih dolenskih najdiščih v kombinacijah s certoškimi in vzhodnoalpskimi živalskimi fibulami ter celo z železnimi samostrelnimi fibulami.¹³⁷⁰ Da so jih uporabljali tudi moški, priča skeletni grob, odkrit v planem grobišču na Pancah pri Šmarju. Pokojnik jo je imel na desnici, ob levi roki pa železno tulasto sekuro in sulično ost pri nogah.¹³⁷¹ Skupaj z orožjem nastopa še v grobu 5/14 iz Dolenskih Toplic, in sicer z železno sekuro z enostranskimi plavutmi ter nožem s ploščatim nastavkom in zakovicami.¹³⁷²

Zapestnice iz tanke ukrivljene pločevine so izdelovali že v času kulture žarnih grobišč, vendar se je tak nakit na Dolenskem vnovič razmahnil v mlajšem halštatskem obdobju. Glede na to, da skorajda vsem

¹³⁶⁶ *Boštanj*: Guštin 1974b, T. 2: 6, 19: 1,2; *Brezje*: Kromer 1959a, T. 25: 2, 49: 5, 50: 2,4; *Čužnja vas*: Dular J. 2003, T. 17: 2; *Dobrnič*: Parzinger 1988–1989, T. 24: 12–22; *Dolenske Toplice*: Teržan 1976, T. 63: 2; *Krajna Brda*: Dular J. 2003, T. 55: 2,3; *Libna*: Guštin 1976, T. 32: 8, 70: 16,17; *Ljubljana*: Puš 1982, T. 50: 1; *Novo mesto*: Knez 1986, T. 13: 7, 18: 4, 21: 8; id. 1993, T. 25: 2; *Roje pri Trebelnem*: Dular J. 2003, T. 29: 8,9; *Rovišče*: Stare V. 1962–1963, T. 1: 3; *Stična*: Wells 1981, Fig. 94g, 98e; Gabrovec et al. 2006, T. 4: 9,10; *Vače*: Stare F. 1955a, T. 69: 6,7, 70: 1,2,4,6,7, 95: 12; *Veliki Vinji vrh (Šmarjeta)*: Stare V. 1973a, T. 33: 1; Dular A. 1991, T. 40: 9,10, 71: 4–6; *Vinkov vrh*: Stare V. 1964–1965, T. 13: 4.

¹³⁶⁷ *Boštanj*: Guštin 1974b, T. 13: 10; *Brezje*: Kromer 1959a, T. 3: 2, 5: 2; *Dobrnič*: Stare V. 1973b, T. 5: 9,10,13, 8: 5; Parzinger 1988–1989, T. 23: 8,9–12, 25: 7–9; *Dole pri Litiji*: Dular J. 2003, T. 92: 4–6; *Dolenske Toplice*: Teržan 1976, T. 2: 3, 4: 10, 6: 8, 30: 2,3, 32:4,6,7; 45: 2, 57: 9, 63: 1; *Ljubljana*: Puš 1982, T. 42: 13; *Novo mesto*: Knez 1986, T. 25: 13, 28: 11,13; id. 1993, T. 25: 3, 27: 3,4; Križ 1997, T. 31: 8–11, 43: 6,7, 47: 10; *Podzemelj*: Dular J. 1978, T. 11: 25; *Stična*: Wells 1981, Fig. 189b; Gabrovec et al. 2006, T. 68: 1–5, 97: 1,2, 186: 42,44, 187: 49; *Vače*: Stare F. 1955a, T. 68: 9, 69: 1–5,8, 70: 5,8; *Valična vas*: Teržan 1973, T. 6: 4–9,11,12; *Veliki Vinji vrh (Šmarjeta)*: Stare V. 1973a, T. 28: 11,15; Dular A. 1991, T. 27: 12, 61: 16, 64: 30, 73: 2,3; *Vintarjevec*: Stare F. 1953, T. 2: 1,2, 3: 3.

¹³⁶⁸ Parzinger/Nekvasil/Barth 1995, 32, 263, Abb. 12.2.

¹³⁶⁹ *Ibid.*, 34, 264, Abb. 13.3.

¹³⁷⁰ *Brezje*: Kromer 1959a, T. 45: 4, 48: 10; *Dole pri Litiji*: Dular J. 2003, T. 92: 7,8; *Dolenske Toplice*: Teržan 1976, T. 9: 11, 27: 4, 28: 7, 32: 6, 58: 6,7; *Novo mesto*: Knez 1986, T. 24: 8, T. 36: 8,9; *Pance*: Dular J. 2003, T. 2: 1; *Stična*: Wells 1981, Fig. 38j; *Vače*: Stare F. 1955a, T. 68: 7,8, 69: 12, 70: 3, 91: 7; *Veliki Vinji vrh (Šmarjeta)*: Dular A. 1991, T. 73: 3; *Vinkov vrh*: Stare V. 1964–1965, T. 13: 2; *Vintarjevec*: Stare F. 1953, T. 3: 1,2.

¹³⁷¹ Dular J. 2003, 154, T. 2: 1–3.

¹³⁷² Teržan 1976, T. 27: 1–7.

The variant is, however, found more frequently with *Certosa fibulae*.¹³⁶³

Also worn in the Late Hallstatt period in Dolenska were the spiral hollow bracelets of Variant V3.¹³⁶⁴ Similar examples from the sites in Notranjska date to the Notranjska V phase (= *Certosa* phase in Dolenska).¹³⁶⁵

An element typical of the female costume of the Dolenska Hallstatt community is hollow bracelets and anklets of Variants V4¹³⁶⁶ and V5.¹³⁶⁷ Parzinger named the ribbed Variant V4 as Variant Brezje¹³⁶⁸ and the densely incised examples as Variant Magdalenska gora.¹³⁶⁹ Such jewellery first appeared in the Stična 2 phase. It remained rare in the contexts of the Serpentine Fibulae phase, became widely used in the *Certosa* and gradually went out of use in the *Negova* phase.

Variant V6 was found at numerous sites in Dolenska, in combination with *Certosa* and East Alpine animal-headed, even with iron crossbow fibulae.¹³⁷⁰ They were

¹³⁶³ *Magdalenska gora-Preloge*, Gr. 13/36, 13/117; *Brezje*, Gr. 13/7: Kromer 1959a, 68, T. 52: 3–5; *Dolenske Toplice*, Gr. 2/19: Teržan 1976, T. 9: 4–11; *Libna*, *Glogovšek Tum. 2/Gr. 7*: Guštin 1976, 41, T. 31: 2,3; *Novo mesto-Znančeve njive*, Gr. 2/19: Knez 1986, T. 21, 22: 1,2, 70.

¹³⁶⁴ *Libna*: Guštin 1976, T. 62: 2, 70: 18; *Stična*: Wells 1981, Fig. 42a; Gabrovec et al. 2006, T. 186: 45, 193: 5,6; *Vače*: Stare F. 1955a, T. 69: 9 and unpublished examples, NHMW Inv. Nos. 3594, 14189; *Valična vas*: Teržan 1973, 682, T. 6: 1–3; *Veliki Vinji vrh (Šmarjeta)*: Stare V. 1973a, T. 28: 14, 33: 2; *Vinkov vrh*: Stare V. 1964–1965, T. 13: 3,6.

¹³⁶⁵ Guštin 1973, 476, Fig. 2: 45; id. 1979, T. 23: 25–31, 27: 8, 67: 10,11.

¹³⁶⁶ *Boštanj*: Guštin 1974b, T. 2: 6, 19: 1,2; *Brezje*: Kromer 1959a, T. 25: 2, 49: 5, 50: 2,4; *Čužnja vas*: Dular J. 2003, T. 17: 2; *Dobrnič*: Parzinger 1988–1989, T. 24: 12–22; *Dolenske Toplice*: Teržan 1976, T. 63: 2; *Krajna Brda*: Dular J. 2003, T. 55: 2,3; *Libna*: Guštin 1976, T. 32: 8, 70: 16,17; *Ljubljana*: Puš 1982, T. 50: 1; *Novo mesto*: Knez 1986, T. 13: 7, 18: 4, 21: 8; id. 1993, T. 25: 2; *Roje pri Trebelnem*: Dular J. 2003, T. 29: 8,9; *Rovišče*: Stare V. 1962–1963, T. 1: 3; *Stična*: Wells 1981, Figs. 94g, 98e; Gabrovec et al. 2006, T. 4: 9,10; *Vače*: Stare F. 1955a, T. 69: 6,7, 70: 1,2,4,6,7, 95: 12; *Veliki Vinji vrh (Šmarjeta)*: Stare V. 1973a, T. 33: 1; Dular A. 1991, T. 40: 9,10, 71: 4–6; *Vinkov vrh*: Stare V. 1964–1965, T. 13: 4.

¹³⁶⁷ *Boštanj*: Guštin 1974b, T. 13: 10; *Brezje*: Kromer 1959a, T. 3: 2, 5: 2; *Dobrnič*: Stare V. 1973b, T. 5: 9,10,13, 8: 5; Parzinger 1988–1989, T. 23: 8,9–12, 25: 7–9; *Dole pri Litiji*: Dular J. 2003, T. 92: 4–6; *Dolenske Toplice*: Teržan 1976, T. 2: 3, 4: 10, 6: 8, 30: 2,3, 32:4,6,7; 45: 2, 57: 9, 63: 1; *Ljubljana*: Puš 1982, T. 42: 13; *Novo mesto*: Knez 1986, T. 25: 13, 28: 11,13; id. 1993, T. 25: 3, 27: 3,4; Križ 1997, T. 31: 8–11, 43: 6,7, 47: 10; *Podzemelj*: Dular J. 1978, T. 11: 25; *Stična*: Wells 1981, Fig. 189b; Gabrovec et al. 2006, T. 68: 1–5, 97: 1,2, 186: 42,44, 187: 49; *Vače*: Stare F. 1955a, T. 68: 9, 69: 1–5,8, 70: 5,8; *Valična vas*: Teržan 1973, T. 6: 4–9,11,12; *Veliki Vinji vrh (Šmarjeta)*: Stare V. 1973a, T. 28: 11,15; Dular A. 1991, T. 27: 12, 61: 16, 64: 30, 73: 2,3; *Vintarjevec*: Stare F. 1953, T. 2: 1,2, 3: 3.

¹³⁶⁸ Parzinger/Nekvasil/Barth 1995, 32, 263, Abb. 12.2.

¹³⁶⁹ *Ibid.*, 34, 264, Abb. 13.3.

¹³⁷⁰ *Brezje*: Kromer 1959a, T. 45: 4, 48: 10; *Dole pri Litiji*: Dular J. 2003, T. 92: 7,8; *Dolenske Toplice*: Teržan 1976, T. 9:

različicam votlih zapestnic in nanožnic najdemo dvojnice v polno ulitih izdelkih, je moč sklepati, da izvirajo iz istega delavniškega kroga (sl. 118).

Magdalenska gora je prispevala največji delež k skupnemu seštevku z vseh dolenskih najdišč in tudi najširši spekter različic votlega obročastega okrasja, zato bi lahko domnevali, da je ena od torevtičnih delavnic delovala prav v tem kraju, kjer so med drugim nemara izdelovali tudi druge predmete iz tanke bronaste pločevine, kot npr. votle ovratnice, valjaste uhane, sceptre itd. Tako imenovano magdalenskogorsko varianto votlih zapestnic po Parzingerju srečamo še na madžarskih najdiščih in v Donji Dolini.¹³⁷³

Tovrsten nakit so nosile predvsem ženske, vendar se pojavlja tudi v moški noši. Ob tem je morda zanimivo omeniti primerek velike votle zapestnice iz Mecklenburške zbirke, ki je objavljena pod najdiščem Hallstatt; okrašena je s snopi vrezov in koncentričnimi krožci, na zunanjem obodu pa ima pare luknjic, v katere so vdeti členi s trikotnimi obeski.¹³⁷⁴ Na oko enako narokvico lahko opazimo na znameniti kamniti skulpturi vojščaka iz Capestrana v Picenumu, ki je datirana v drugo četrtino 6. st. pr. n. št.¹³⁷⁵ Na figuralno okrašeni pasni sponi z Brezij pa imata ženski na nogah nanožnice, ki spominjajo na votle obroče med prdatki dolenskih grobov.¹³⁷⁶

4.9.3 SVINČENE NAROKVICE

Tipološke značilnosti. Obroče, ki so uliti iz svinčevo-cinkove zlitine, je med predmeti iz Mecklenburške zbirke izpostavil že Hencken.¹³⁷⁷ Njihova velikost in debelina sta tako rekoč standardni, skoraj vsi merijo v premeru okoli 10 cm, v preseku pa približno 1,2 cm. Nekateri so gladki s prisekanimi robovi (sl. 119: 1), drugi so okrašeni z dvema, tremi ali petimi vzdolžnimi rebri (sl. 119: 2–4).

Lega in kontekst. Na Magdalenski gori je zabeleženih vsega skupaj trinajst svinčenih narokvic, največ pa jih izvira iz gomil 2 in X na Prelogah.¹³⁷⁸ Najdene so bile v grobovih, ki so po podatkih izkopavalcev ležali dokaj plitvo pod površjem (od 10 do 155 cm) in mnogokrat na robu gomile, edinole grob X/25 je imel menda bolj osrednjo lego. Okostja v teh grobovih so bila očitno precej dobro ohranjena, nekatera med njimi je analiziral Angel in ugotovil, da sta bila v grobovih X/64 in X/25 pokopana mlada odrasla moška, medtem ko je lobanjo

worn by men, as indicated by the inhumation grave from a flat cemetery at Pance near Šmarje. The deceased in this grave had one example on his right arm, an iron socketed axe beside his left arm and a spearhead at his feet.¹³⁷¹ This variant was also found together with weapons, namely an iron one-sided winged axe and a knife with a flat tang and rivets, in Grave 5/14 at Dolenske Toplice.¹³⁷²

Bracelets made of thin curved sheet bronze were being made already during the Urnfield culture period. After that, jewellery of this kind again became popular in Dolenska during the Late Hallstatt period. Considering the fact that almost all variants of hollow bracelets and anklets have their pairs in the solid cast products, we might say that all originate from the same workshop circle (fig. 118).

Of all the sites in Dolenska, Magdalenska gora made the greatest contribution to the region's hollow ring jewellery in both quantity and formal variety. It would thus be possible to suppose one of the toreutic workshops operating at this site, which might also have produced other items made of thin sheet bronze, such as hollow torques, cylindrical earrings, sceptres and others. It is noteworthy that Parzinger's Magdalenska gora variant of hollow bracelets was also found at sites in Hungary and at Donja Dolina.¹³⁷³

Hollow ring jewellery was worn primarily by women, occasionally also by men. It even found their way into art depictions. One correlation between object and art depiction can be observed in a large hollow bracelet from the Mecklenburg Collection published under the site of Hallstatt; it is decorated with groups of incisions and concentric circles and has pairs of holes through which triangular pendants are suspended.¹³⁷⁴ Seemingly the same armlet can be observed on the famous stone sculpture of the Capestrano Warrior from Picenum, dated to the second quarter of the sixth century BC.¹³⁷⁵ Another correlation can be established between the belt clasp with figural decoration from Brezje, which shows a woman with a hollow anklet on each of her legs,¹³⁷⁶ similar to the Variant V5 rings, which appear in the graves of the Dolenska community.

¹³⁷³ Parzinger/Nekvasil/Barth 1995, 34 ss; 264 (Listen), Abb. 13: 3; Marič 1964, T. 14: 14.

¹³⁷⁴ Wells 1981, Fig. 27b.

¹³⁷⁵ von Hase 2003, T. IIIc, idr.

¹³⁷⁶ Barth 1999, Abb. 1; Turk 2005, 55, sl. 43, 83.

¹³⁷⁷ Hencken 1974.

¹³⁷⁸ Hencken 1978, Fig. 216a, 218c; 307b; 312g; 317f; 350f; Tecco Hvala/Dular/Kocuvan 2004, T. 13: 1,2; 17A: 3; 17B: 2, 19A: 5, 77B: 2,3.

11, 27: 4, 28: 7, 32: 6, 58: 6,7; *Novo mesto*: Knez 1986, T. 24: 8, T. 36: 8,9; *Pance*: Dular J. 2003, T. 2: 1; *Stična*: Wells 1981, Fig. 38j; *Vače*: Stare F. 1955a, T. 68: 7,8, 69: 12, 70: 3, 91: 7; *Veliki Vinji vrh (Šmarjeta)*: Dular A. 1991, T. 73: 3; *Vinkov vrh*: Stare V. 1964–1965, T. 13: 2; *Vintarjevec*: Stare F. 1953, T. 3: 1,2.

¹³⁷¹ Dular J. 2003, 154, T. 2: 1-3.

¹³⁷² Teržan 1976, T. 27: 1-7.

¹³⁷³ Parzinger/Nekvasil/Barth 1995, 34 ff, 264 (Listen), Abb. 13: 3; Marič 1964, T. 14: 14.

¹³⁷⁴ Wells 1981, Fig. 27b.

¹³⁷⁵ von Hase 2003, T. IIIc, etc.

¹³⁷⁶ Barth 1999, Abb. 1; Turk 2005, 55, figs. 43, 83.

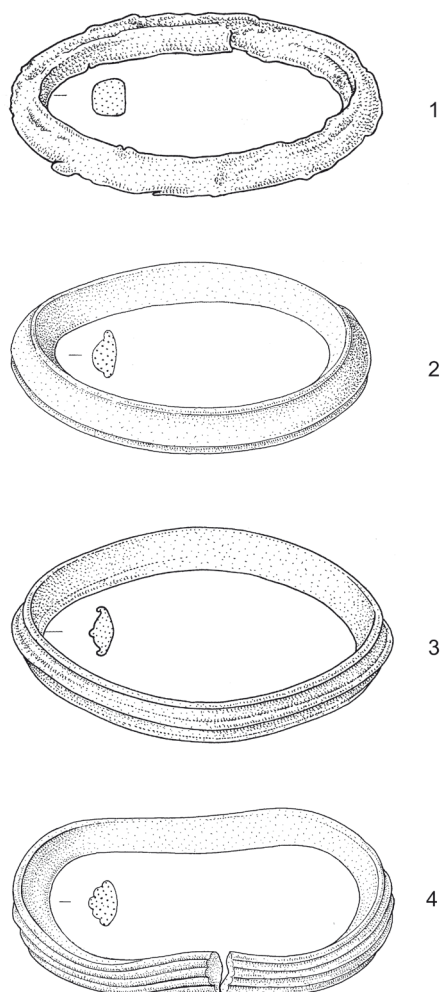

Sl. 119: Tipi svinčenih narokvic z Magdalenske gore. M. = 1:2.
Fig. 119: Types of lead armlets from Magdalenska gora.
Scale = 1:2.

1 – Preloge, gr. 2/3 (Pb1); 2, 3 – Preloge, gr. 13/37 (Pb2, Pb3);
4 – Preloge, gr. 2/8 (Pb4).

iz groba X/18 opredelil za žensko, kar je presenetljivo, saj pridano orožje govori za pokop moškega.¹³⁷⁹ Položaj teh predmetov na okostjih je razviden iz opisov in risb grobov (sl. 37). Pokojnik v grobu X/21a je imel svinčeno narokvico na levi nadlahtnici, medtem ko jo je moški, pokopan v grobu X/25, nosil na desnici. V opisu groba X/18 Goldberg omenja svinčen obroč na zgornjem delu roke, pri okostju v grobu X/64 pa na desni podlahtnici.

Svinčene narokvice se na Magdalenski gori pojavljajo v kombinacijah s tulasto¹³⁸⁰ ali z uhato sekiro (sl. 120).¹³⁸¹ Moški v grobu X/64 je imel poleg vitke tulaste sekire še eno z enostranskimi plavutmi, nož s ploščatim nastavkom za koščen držaj, dve vitki sulični osti in eno

¹³⁷⁹ Angel 1968, 75 ss.

¹³⁸⁰ Preloge, gr. 2/3, X/18, X/21a, X/25, X/64.

¹³⁸¹ Preloge, gr. 2/j, 13/37.

4.9.3 LEAD ARMLETS

Typological characteristics. Cast rings of a lead-zinc alloy from the Mecklenburg Collection were discussed already by Hencken.¹³⁷⁷ They show an almost standard diameter and thickness; roughly 10 and 1.2cm, respectively. Some are plain with slanting sides (fig. 119: 1) and others decorated with two, three or five longitudinal ribs (fig. 119: 2–4).

Position and context. Altogether thirteen lead armlets have been documented at Magdalenska gora, most in Tumuli 2 and X at Preloge.¹³⁷⁸ The graves in question were found at relatively shallow depths beneath the surface (10 to 155cm) and often on the edge of the tumulus, with the only exception being Grave X/25 with a more central position. These graves revealed rather poorly preserved skeletons. Some were analysed by Angel, who established that a young male adult was buried in each of Graves X/64 and X/25, while he found the skull from Grave X/18 to have belonged to a woman. The latter is surprising, since the weapons found beside the skeleton rather indicate a male burial.¹³⁷⁹ The position of lead rings on the skeletons can be discerned from notes and drawings (fig. 37). The deceased in Grave X/21a, for example, had a lead armlet on his left upper arm, while the man buried in Grave X/25 wore it on his right arm. When describing Grave X/18, Goldberg mentions a lead ring on the upper part of the arm, while for the skeleton in Grave X/64 he noted a lead ring on the right forearm.

Lead armlets appear at Magdalenska gora in combination with a socketed¹³⁸⁰ or a shaft-hole axe (fig. 120).¹³⁸¹ The man buried in Grave X/64 had, besides the armlet, a slender socketed and a one-sided winged axe, a knife with a flat tang for a bone handle, two slender spearheads and a javelin. Included into the grave group are also two spearheads from the museum in Ljubljana, which are not mentioned by Goldberg.

An item common to all the grave groups that include a lead armlet is large Certosa fibulae, which can appear either singly or in pairs. Grave Group 2/j is only partially reconstructed and is composed of armlets, horse gear, ring strap decoration, two fibulae, a pair of spears, a knife and a crushed bronze cauldron, whereby the latter could not be identified among the finds from the museum in Ljubljana. Similar bronze decoration, which formed part of either a belt set or horse gear, was found in Graves X/25 and 2/5. Inventoried as part of the latter are also pieces of lead armlets, which are not listed by Pečnik, but could

¹³⁷⁷ Hencken 1974.

¹³⁷⁸ Hencken 1978, Figs. 216a, 218c; 307b; 312g; 317f; 350f; Tecco Hvala/Dular/Kocuvan 2004, T. 13: 1,2; 17A: 3; 17B: 2, 19A: 5, 77B: 2,3.

¹³⁷⁹ Angel 1968, 75 ff.

¹³⁸⁰ Preloge, Gr. 2/3, X/18, X/21a, X/25, X/64.

¹³⁸¹ Preloge, Gr. 2/j, 13/37.

Gom. / gr. Tum. / Gr.	Pokop / Burial rite	Spol / starost Sex / Age	Tip narokvic / Types of armrings	Št. narokvic / No. of armrings	Fibule / Fibulae	Sekire / Axes	Sulice / Spears	Noži / Knives	Pasni okovi / Belt attachments	Fe obročki / Fe rings	Obeski / Pendants	Šilo / Awl	Konjska oprema / Horse equipment	Lončenina / Pottery	Bronasto posodje / Bronze vessels
P VI/42	C?	?	Pb 1	1	3									1	
P 2/3	?	M		1	2	1									
P 2/j	S	M		2	2	1	2	1	x				x		1
P X/21a	S	M	Pb 2	1	2	1	2	1							
P X/25	S	M		1		1	2?	1	x		x		x		
P X/18	S	M		1		1	1			1		1			
P 2/8	?	?		1	1										
P X/64	S	M	Pb 3	1	1	2	3	1		x					
P 13/37	S	M	Pb2 + Pb4	1+1	1	1		1		1					

Sl. 120: Struktura pridatkov v grobovih s svinčnimi narokvicami na Magdalenski gori.

Fig. 120: Structure of goods in the graves with lead armlets at Magdalenska gora.

kopje. V to grobno celoto sta vključeni še dve sulici iz ljubljanskega muzeja, ki ju Goldberg ne omenja.

Skupna značilnost oprav s svinčnimi narokvicami so velike certoške fibule, ki nastopajo posamično ali v paru. Grobna celota 2/j je le delno rekonstruirana, poleg narokvic in konjske opreme ter obročastega jermenskega okrasja naj bi ji pripadali še dve fibuli, par sulic in nož ter zdrobljen bronast kotliček, ki jih med najdbami v ljubljanskem muzeju nismo mogli identificirati. Podobno bronasto okrasje, ki je sestavljalo pasno garnituro ali konjsko opremo, je bilo prav tako najdeno v grobovih X/25 in 2/5. V slednjem so inventarizirani koščki svinčenih zapestnic, ki jih Pečnik v popisu najdb sicer ne navaja, vendar bi bil tak sestav pridatkov možen, seveda brez železnega kresila in ostankov umba.

Razširjenost in časovni okvir. Na drugih dolenjskih najdiščih so svinčene narokvice precej slabše zastopane.¹³⁸² V Dobrniču je bila najdena v kombinaciji s certoškima fibulama vrste X v grobu 4/11, ki je ležal 30 cm pod površjem gomile. V Dolenjskih Toplicah nastopa med pridatki groba 11/20 skupaj s certoško fibulo vrste VIII in podobnimi okroglimi okovi, kot so zastopani v magdalenskogorskih grobovih.¹³⁸³ Svinčena zapestnica

have formed part of the grave group, of course without the iron fire-striker and remains of an umbo.

Distribution and time frame. Other sites of Dolenjska revealed considerably less lead armlets.¹³⁸² At Dobrnič, for example, one was unearthed together with two Type X Certosa fibulae in Grave 4/11, found just 30cm beneath the surface of the tumulus. At Dolenjske Toplice, a lead armlet was found in Grave 11/20 together with a Type VIII Certosa fibula and similar round fittings to those from Magdalenska gora.¹³⁸³ A lead bracelet is also mentioned in the most prestigious grave group at Dolenjske Toplice, namely 5/17, which contained the burial of a chieftain, with a Negova helmet, and of a female.¹³⁸⁴

The lead armlets are mainly limited to central Dolenjska and could thus be seen as local products.¹³⁸⁵ Outside this area, only two examples were found in Notranjska.¹³⁸⁶ The appearance of lead armlets is limited also chronologically, since they were only found with the latest types of Certosa fibulae, namely VIII, X and XI,

¹³⁸² Dobrnič: Parzinger 1988–1989, T. 22: 6; Dolenjske Toplice: Teržan 1976, T. 66: 14, 90: 11; Mokronog: neobjavljeno, NMS inv. št. P 1755, 1756; Stična: Gabrovec et al. 2006, T. 128: 1, 175: 79,80, 186: 46; Valična vas: Teržan 1973, T. 5: 10, 11; Velike Malence: Dular J. 2003, T. 60: 7.

¹³⁸³ Teržan 1976, 368, 391, 408, sl. 38.

¹³⁸² Dobrnič: Parzinger 1988–1989, T. 22: 6; Dolenjske Toplice: Teržan 1976, T. 66: 14, 90: 11; Mokronog: unpublished, NMS Inv. Nos. P 1755, 1756; Stična: Gabrovec et al. 2006, T. 128: 1, 175: 79,80, 186: 46; Valična vas: Teržan 1973, T. 5: 10, 11; Velike Malence: Dular J. 2003, T. 60: 7.

¹³⁸³ Teržan 1976, 368, 391, 408, Abb. 38.

¹³⁸⁴ Ibid., 401, T. 9: 4-11, 90A: 11.

¹³⁸⁵ Hencken 1974; Parzinger 1988, T. 149: 2 (distribution map).

¹³⁸⁶ Tržišče near Cerknica and Šmihel: Guštin 1979, T. 23: 24, 67: 12.

se omenja tudi v sklopu najprestižnejšega topliškega groba 5/17, v katerem je bila poleg poglavarja z negovsko celado pokopana ženska.¹³⁸⁴

Glede na to, da je pojav svinčenih narokvic omejen v glavnem na osrednji dolenski prostor, jih lahko označimo za lokalno posebnost.¹³⁸⁵ Izven tega teritorija sta znana le še dva primerka z Notranjske.¹³⁸⁶ Omejene pa niso le prostorsko, temveč tudi kronološko, saj se povezujejo le z najmlajšimi variantami certoških fibul, tj. vrst VIII, X in XI, ki so jih nosili moški v času negovske stopnje.¹³⁸⁷ Ta čas prav tako odražajo uhate sekire, dolge vitke sulične osti in nož s ploščatim nastavkom za ročaj.¹³⁸⁸ Stratigrafska lega teh grobov tik pod površjem in na obodu gomil pa pritrjuje domnevi, da je šlo za najmlajše pokope.

Svinčene narokvice bi morda lahko primerjali z obroči iz drugih materialov, kot npr. iz pozidonijskega skrilavca, sapropelita ali lignita, ki se pojavljajo v moški noši poznohalštatskega in zgodnjelatenskega obdobja na srednjeevropskem prostoru.¹³⁸⁹ Da je bila dolenska halštatska skupnost dovzetna za nove ideje, ki so vzniknile v osrčju zgodnjelatenske kulture, in jih je po svoje interpretirala, potrjujejo še drugi izdelki, kot so npr. železne fibule in predrte pasne spone.

4.9.4 ZAKLJUČEK

Najstarejši primerek obročastega nakita v arheološki zapuščini Magdalenske gore predstavlja zapestnica iz bronaste trakaste pločevine z zaobljenima koncema,¹³⁹⁰ kakršne srečamo v nekropolah iz časa kulture žarnih grobišč (Ljubljana, Mokronog, Tolmin).¹³⁹¹

V železni dobi je obročast nakit spadal med tipične sestavine dolenske noše (*sl.* 121). V času stopnje Podzemelj (= Ljubljana IIb in IIIa) so se nosile železne in bronaste sklenjene zapestnice (različica **Ic** = tip Poštela po Teržanovi), v stopnji Stična je železen nakit izginil, pojavile pa so razne variante bronastih zapestnic in nanožnic, diapazon oblik, tehnik izdelave in kombinacij pa je bil takrat najširši. Uveljavile so se oblike s presegajočimi konci (različice **IIa–c**), pojavili so se tudi prvi narebreni in votli primerki (različice **III, IV** in **V4**). Ob tem zasledimo nekatere redke kose, kot so zapestnice z rombičnim pre-

¹³⁸⁴ Ibid., 401, T. 9: 4-11, 90A: 11.

¹³⁸⁵ Hencken 1974; Parzinger 1988, T. 149: 2 (karta razprostranjenosti).

¹³⁸⁶ *Tržišče pri Cerknici in Šmihel*: Guštin 1979, T. 23: 24, 67: 12.

¹³⁸⁷ Teržan 1976, 368, 392, sl. 36, 37.

¹³⁸⁸ Teržan/Trampuž 1973, 434; Teržan 1973, 685, 689; ead. 1976, 393; ead. 1977, 13 s.

¹³⁸⁹ Lorenz 1978, 136 ss; Pauli 1984, 89 s, Abb. 3: 5; Sievers 1984, 12, T. 19, 21: 316, 23: 327,328, 26: 340; Parzinger/Nekvasil/Barth 1995, 43, T. 13: 122, 123.

¹³⁹⁰ Tecco Hvala/Dular/Kocuvan 2004, T. 149: 12.

¹³⁹¹ Puš 1971, T. 1: 12; Gabrovec 1973, T. 10: 18; Svöljšak/Pogačnik 2001, T. 45: 7, 54: 4, 69: 14; id. 2002, 53 (varianta 1a).

worn by men during the Negova phase.¹³⁸⁷ This time frame is confirmed by the shaft-hole axes, long and slender spearheads and a knife with a flat tang.¹³⁸⁸ The late date is further confirmed by the stratigraphic position of the burials with this type of rings just beneath the tumulus surface and along tumulus edges.

Lead armllets could be compared to rings of other materials, for example of posidonia shale, sapropelite or lignite, which appear in the male costume of the Late Hallstatt and Early La Tène periods in central Europe.¹³⁸⁹ The susceptibility of the Dolenska Hallstatt community to novel ideas generated in the heart of the Early La Tène culture, which it reinterpreted, is underlined by other products, such as iron fibulae and openwork belt clasps.

4.9.4 CONCLUSION

The earliest example of ring jewellery from Magdalenska gora is the bracelet made of a band of sheet bronze with rounded ends,¹³⁹⁰ such as were found in the cemeteries of the Urnfield culture period (Ljubljana, Mokronog, Tolmin).¹³⁹¹

In the Iron Age, ring jewellery formed a typical element of the Dolenska costume (*fig.* 121). Iron and bronze annular bracelets (Variant **Ic** = Type Poštela after Teržan) were worn during the Podzemelj phase (= Ljubljana IIb and IIIa). In the Stična phase, iron jewellery disappeared and made place for various bronze bracelets and anklets, whereby the variety of forms, production techniques and combinations was at its greatest. The most popular were rings with overlapping ends (Variants **IIa–c**). The Stična phase saw the first ribbed and hollow examples (Variants **III, IV** and **V4**). Also worn were several rare pieces, such as bracelets of rhombic cross-section or with longitudinal grooves (*fig.* 109:10 and *fig.* 111:16); whereby the former may be relicts from the Urnfield culture period and the latter imports from northern Italy. Also popular during the Stična phase was wearing anklets in sets, which can later no longer be observed.

The ring jewellery of the Serpentine Fibulae phase shows a uniformity of style, that is less differentiation in costume. The “ribbed style” (Variants **IIIa** and **IIIb**) became popular, as well as wearing one or two bracelets, less commonly in combination with a pair of anklets. Children’s bracelets, on the other hand, retained the decoration

¹³⁸⁷ Teržan 1976, 368, 392, Abb. 36, 37.

¹³⁸⁸ Teržan/Trampuž 1973, 434; Teržan 1973, 685, 689; ead. 1976, 393; ead. 1977, 13 f.

¹³⁸⁹ Lorenz 1978, 136 ff; Pauli 1984, 89 f, Abb. 3: 5; Sievers 1984, 12, T. 19, 21: 316, 23: 327,328, 26: 340; Parzinger/Nekvasil/Barth 1995, 43, T. 13: 122, 123.

¹³⁹⁰ Tecco Hvala/Dular/Kocuvan 2004, T. 149: 12.

¹³⁹¹ Puš 1971, T. 1: 12; Gabrovec 1973, T. 10: 18; Svöljšak/Pogačnik 2001, T. 45: 7, 54: 4, 69: 14; id. 2002, 53 (Variant 1a).

sekom ali vzdolžno nažlebljene (sl. 109:10 in sl. 111:16); prve so morda prežitek iz časa kulture žarnih grobišč, druge import iz severnoitalskega prostora. Prav tako se je v stopnji Stična razmahnila noša nanožnic v garniturah, sestavljenih iz več kosov, česar pozneje ne zasledimo več.

V stopnji kačastih fibul je v obročastem nakitu opazno poenotenje stila, noša pa je zdaj manj diferencirana. Uveljavila sta se "narebreni stil" (različici IIIa in IIIb) in nošnja ene ali dveh zapestnic, bolj redko v kombinaciji s parom nanožnic, medtem ko se je na otroških zapestnicah ohranil okras s snopi vrezov (različici IIb in IVb),

of stripes of incisions (Variants IIb and IVb), which also appeared on small spiral bracelets (Variants S2).

The fashion in the Certosa phase was, besides for the solid ribbed variants, for jewellery made of tubular sheet bronze (Variants V1–V5), which largely copies the solid cast examples in form and decoration (fig. 118). Women mostly wore hollow bracelets and anklets, in pairs, while men and children wore various types of bracelets or armllets, namely solid cast, hollow and spiral (Variants Ia, IIa, IIIc, V5, V6, S3, S4). Also observable is that the male costume mostly contained a single armllet.

A

Zapestnice in nanožnice / Bracelets and anklets (n = 2298)

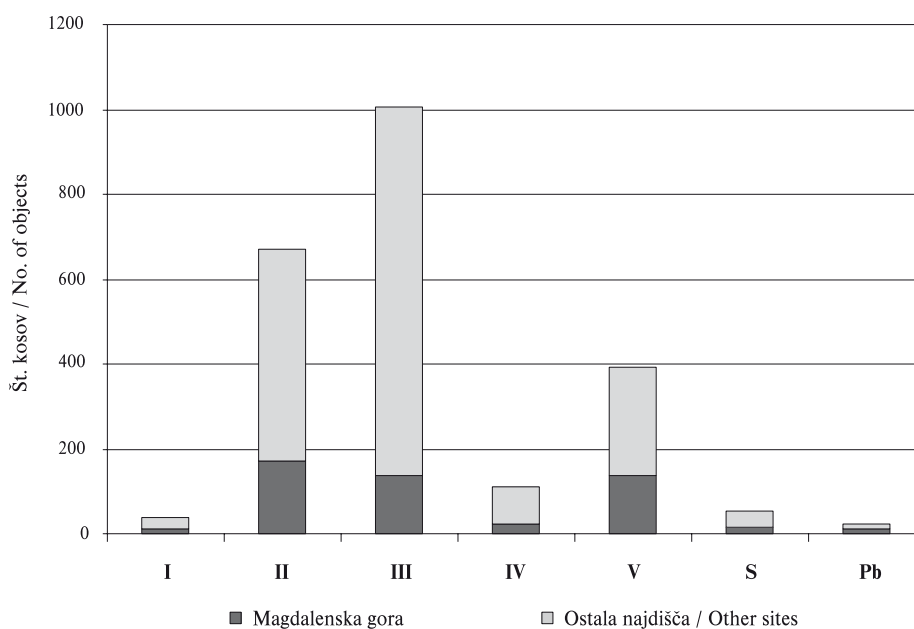

B

Stopnje / Phases	Vrste zapestnic in nanožnic / Types of bracelets and anklets
Podzemelj	I
Stična	II
Kačaste fibule Serpentine fibulae	III, S2
Certoške fibule Certosa fibulae	IV/V, S3/S4
Negovske čelade Negova helmets	Pb

Sl. 121: Številčna zastopnost (A) in časovni razpon (B) raznih tipov obročastega nakita v dolenski skupnosti.
Fig. 121: Quantitative ratio (A) and chronological span (B) of ring jewellery types in the Dolenjska community.

ki se pojavlja tudi na majhnih spiralnih zapestnicah (različica **S2**).

V stopnji certoških fibul je ob masivnih narebrenih različicah prišel v modo nakit, izdelan iz cevasto ukrivljene bronaste pločevine (različice **V1–V5**), ki v oblikah in okrasnih prvinah v dobršni meri posnema polno ulite primerke (*sl. 118*). Votle zapestnice in nanožnice so v glavnem nosile ženske, in sicer v parih, medtem ko so moški in otroci nosili različne tipe zapestnic oz. narokvic, tako polno ulite kot votle in spiralne (različice **Ia, IIa, IIIc, V5, V6, S3, S4**). Razen tega v moških opravah povečini nastopa le ena narokvica.

V negovski stopnji so moški pričeli uporabljati svinčene narokvice (**Pb**), ženske in deklice pa tanke ulite bronaste zapestnice z zakovičenimi konci (različica **IIIId**) ali izdelane iz spiralno zvite žice oz. traku (različica **S1**), ki jih zasledimo tudi v grobovih iz latenskega obdobja. Iz poznolatskih grobov, ki so bili vkopani v gomile na Magdalenski gori, pa je znanih nekaj steklenih in bronastih zapestnic.¹³⁹²

Magdalenska gora je v starejšem halštatskem obdobju izstopala z največjim številom oprav, v katerih nastopajo garniture nanožnic. Prav tako se ponaša z redkima vrstama zapestnic, kot sta različici z rombičnim presekom ali vzdolžno nažlebljenim okrasom. V mlajšem halštatskem obdobju je s tretjinskim deležem votlih in spiralnih primerkov ter z več kot polovičnim deležem svinčenih izdelkov v samem vrhu med dolenjskimi najdišči (*sl. 121*), kar je še en namig na obstoj delavnice v tem kraju. Večina predstavljenih različic iz tega časa je omejena v glavnem le na prostor dolenjske halštatske skupnosti, zato lahko tak obročasti nakit interpretiramo kot "emblematično" prvino noše te pokrajine.

Men in the Negova phase began wearing lead armllets (**Pb**), while women and girls began wearing thin cast bronze bracelets with riveted ends (Variant **IIIId**) or bracelets made of spiral wire or bronze sheet band (Variant **S1**), which are also found in the graves from the La Tène period. The Late La Tène graves dug into tumuli at Magdalenska gora revealed several glass and bronze bracelets.¹³⁹²

Among the sites in Dolenjska, Magdalenska gora revealed the highest number of grave groups with sets of anklets dated to the Early Hallstatt period. It also boasts two rare variants of bracelets, namely with rhombic cross-section and with longitudinal grooves. In the Late Hallstatt period, it contributed one third of all hollow and spiral examples as well as over a half of all lead examples (*fig. 121*), which is further indication of a production activity at the site. Most of the above-discussed variants of ring jewellery is limited mainly to the area of the Dolenjska community and is therefore considered as an emblematic element of its costume.

¹³⁹² Hencken 1978, Fig. 35b, 251c,d; Tecco Hvala/Dular/Kocuvan 2004, 34, T. 20A: 3, 149: 11.

¹³⁹² Hencken 1978, Figs. 35b, 251c,d; Tecco Hvala/Dular/Kocuvan 2004, 34, T. 20A: 3, 149: 11.

4.10 UHANI IN LASNI OBROČKI

Uhane, obsenčnike ali lasne obročke lahko pripišemo k naglavnemu okrasju magdalenskogorskih žena. Med njimi zasledimo izdelke iz bronaste žice okroglega (sl. 122: 1, 18) ali pravokotnega preseka s sredinsko kaneluro (sl. 122: 2–4), največ pa jih je izdelanih iz tanke bronaste pločevine (sl. 122: 5–17). Značilne tipe tovrstnega nakita za posamezne kronološke stopnje je predstavil že Gabrovec v svojih študijah jugovzhodnoalpske halštatske kulture. Teržanova je posvetila posebno pozornost primerkom, ki so izdelani iz zlata žice, z valjastimi uhanj iz bronaste pločevine se je ukvarjal Gleirscher, svetolucijski tip ulitih trakastih uhanov pa je obdelal Kos.¹³⁹³

Uhane in lasne obročke z Magdalenske gore sem obravnavala že na drugem mestu,¹³⁹⁴ zato bom tukaj izpostavila predvsem kombinacije in kontekste, v katerih nastopajo.

¹³⁹³ Gabrovec 1964–1965a, 21 ss, T. 10; id. 1966a, T. 10: 14-19; id. 1973, 357, 371, sl. 2, T. 5: 25, 26, 10: 8-19; id. 1987, 49 ss, sl. 3, 4, 6; Teržan 1976, 384, 388, Fig. 54: 7,13,21,25; ead. 2002; Gleirscher 1997, T. 1: 8-12, 2: 13-17; Kos 1973, 860, karta 1.

¹³⁹⁴ Tecco Hvala 2007.

4.10 EAR- AND HAIR-RINGS

The women from Magdalenska gora adorned their heads with earrings as well as temple- or hair-rings. These were made either of bronze wire of a round (fig. 122: 1, 18) or rectangular cross-section with a central groove (fig. 122: 2–4), or of thin sheet bronze (fig. 122: 5–17), the latter being predominant. The types of this jewellery characteristic of individual phases were already presented by Gabrovec in his studies of the South-Eastern Alpine Hallstatt culture. Teržan paid special attention to the examples made of gold wire, Gleirscher to the cylindrical earrings made of sheet bronze, while the Sveta Lucija type of cast band earrings was analysed by Kos.¹³⁹³

Ear- and hair-rings from Magdalenska gora were already discussed in a previous publication,¹³⁹⁴ wherefore the presentation below focuses on the combinations and contexts in which they appear.

¹³⁹³ Gabrovec 1964–1965a, 21 ff, T. 10; id. 1966a, T. 10: 14-19; id. 1973, 357, 371, Abb. 2, T. 5: 25, 26, 10: 8-19; id. 1987, 49 ff, figs. 3, 4, 6; Teržan 1976, 384, 388, Fig. 54: 7,13,21,25; ead. 2002; Gleirscher 1997, T. 1: 8-12, 2: 13-17; Kos 1973, 860, Karte 1.

¹³⁹⁴ Tecco Hvala 2007.

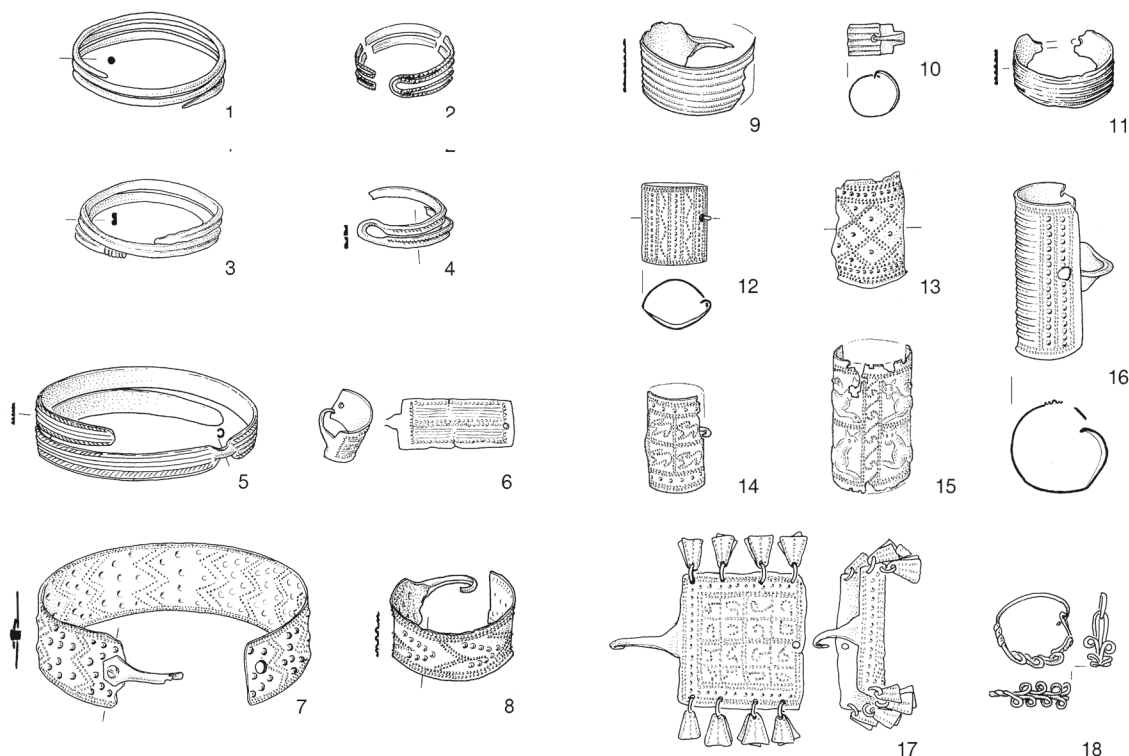

Sl. 122: Tipi bronastih uhanov in lasnih obročkov z Magdalenske gore. M. = 1:2.

Fig. 122: Types of bronze ear- and hair-rings from Magdalenska gora. Scale = 1:2.

1 – Preloge, gr. 2/48 (1); 2 – Preloge, gr. X/61 (4); 3 (3), 5 (5a), 7 (5b) – posamezne najdbe v NMS / stray finds in the NMS; 4 – Preloge, gr. 13/112 (4); 6 – Preloge, gr. X/56 (6a); 8 – Preloge, gr. 2/54 (6b); 9 – Voseleca, gr. 2/12 (6c); 10 – Preloge, gr. 4/2 (6c); 11 – Preloge, gr. 13/24 (svetolucijski tip / Sv. Lucija type); 12 – Voseleca, gr. 2/8 (7a); 13 – Voseleca, gr. 1/1 (7a); 14–16 – Preloge, gr. 13/117 (7b); 17 – Preloge, gr. IV/19 (7c); 18 – Preloge, gr. IV/41 (8).

4.10.1 ŽIČNATI UHANI ALI LASNI OBROČKI

Obročki iz spiralno zvite bronaste žice, ki jih označujem kot tip 1 (*sl. 122: 1*), nastopajo običajno v parih (*sl. 123*).¹³⁹⁵ Primerka v žganem grobu 13/158 s Prelog sta bila obešena na kačasto fibulo severnoitalskega tipa z dvema zankama (*fibula ad arco serpeggiante a gomito*), medtem ko sta bila v skeletnem grobu 2/48 na Prelogah najdena ob glavi pokojnice, ki je imela še trortasto fibulo s čolničastim lokom (= I. vrsta po Ogrinovi), na kateri sta visela dva trakasta obročka različice 5a.

Bolj pogosti so uhani tipa 3 (*sl. 122: 3*), ki so izdelani iz žice pravokotnega preseka z vzdolžno kaneluro in imajo presegajoče konce.¹³⁹⁶ Zasledimo jih izključno v skeletnih grobovih, kjer nastopajo v paru. V poročilih izkopavalcev je večkrat omenjeno, da so se nahajali pri glavah pokojnic. Največ primerkov je znanih iz gomile 13 na Prelogah (*sl. 123*), kjer jih zasledimo v kombinacijah z jantarno ogrlico in s kačastimi fibulami s pestiči ali s sedlastim lokom. Med njimi izstopa oprava deklice ali mladenke z Voselce (2/6), ki je imela štiri fibule (dve čolničasti vrst 1a in 2b po Jerinovi, italsko dvortasto in sanguisuga) ter diadem, sceptor, gladek in narebren obročasti nakit, kar priča, da se je tak tip uhanov pojavil že v stopnji Stična.

Obročki tipa 4 so prav tako izdelani iz žice pravokotnega preseka, vendar s pregibom (*sl. 122: 2, 4*).¹³⁹⁷ Tudi ti se pojavljajo le v skeletnih grobovih in običajno ob glavi (*sl. 123*). V teh opravah srečamo kačasto fibulo s krilci (Preloge, gr. X/61) ali certoški vrste II ter narebreno masivno zapestnico (Preloge, gr. 2/83).

Iz bronaste žice so izdelani še uhani tipa 8 (*sl. 122: 18 in sl. 123*) s pentljami.¹³⁹⁸ Dva sta bila najdena v grobu 13/43 s Prelog skupaj z drobno polno ulito narebreno zapestnico, drobnimi jantarnimi in steklenimi jagodami z izrastki ter železnim nožičkom.¹³⁹⁹ Pripadnost takih uhanov grobnim celotam 2/5 in 2/29 s Prelog je vprašljiva, saj jih Pečnik v popisu inventarja ne omenja. Nezanosljiv je tudi sestav IV/41 s Prelog, kjer sta med drugim objavljena kačasta fibula s sedlastim lokom in dvojnopavkasta fibula, ki časovno zagotovo ne sodita skupaj.

¹³⁹⁵ Tecco Hvala/Dular/Kocuvan 2004, T. 47A: 6,7, 121A: 1.

¹³⁹⁶ Hencken 1978, Fig. 20a, 38c, 49a, 158d,e, 341e; Tecco Hvala/Dular/Kocuvan 2004, T. 70A: 1,2, 73A: 1,2, 90E: 1, 96F: 3, 98B: 2, 102D: 1, 121B: 1, 133: 10,11; 147: 1-4.

¹³⁹⁷ Hencken 1978, Fig. 104a, 348c,d; Tecco Hvala/Dular/Kocuvan 2004, T. 62C: 1,2, 102B: 1,2.

¹³⁹⁸ Hencken 1978, Fig. 82k; Tecco Hvala/Dular/Kocuvan 2004, T. 19A: 1, 31B: 4, 78C: 1,2.

¹³⁹⁹ Primerka iz tega groba B. Glunz-Hüsken (2008, 46) uvršča med fibule z zankastim lokom, t. i. *Schleifenbogenfibeln*, datirane v čas Ha D1.

4.10.1 WIRE EAR- OR HAIR-RINGS

Small rings made of spiral bronze wire, marked as Type 1 (*fig. 122: 1*), usually appear in pairs (*fig. 123*).¹³⁹⁵ The two examples from cremation Grave 13/158 at Preloge were threaded onto a serpentine fibula of the North Italian type with two loops (*fibula ad arco serpeggiante a gomito*), while two others were found in inhumation Grave 2/48 at Preloge beside the head of the female, who also had a three-knobbed fibula of Type I after Ogrin with two band rings of Variant 5a threaded onto it.

More numerous are earrings of Type 3 (*fig. 122: 3*), made of wire of rectangular cross-section with a longitudinal groove and overlapping ends.¹³⁹⁶ These were found exclusively in inhumation graves and only in pairs. Excavators' notes often mention finding them near the heads of the females. The greatest number of them was found in Tumulus 13 at Preloge (*fig. 123*), in combination with an amber necklace and with serpentine fibulae either with antennae or with a saddle-shaped bow. Standing out among the grave groups is that of a girl or a young woman buried at Voselca (2/6), which consisted of four fibulae (two boat of Types 1a and 2b after Jerin, one Italic two-knobbed and one leech), a diadem, a sceptre, as well as plain and ribbed ring jewellery. This grave group shows that the type of earrings already appeared in the Stična phase.

Rings of Type 4 are also made of wire of rectangular cross-section, but the wire is doubled (*fig. 122: 2, 4*).¹³⁹⁷ They also appear only in inhumation graves and usually beside the head (*fig. 123*). They were found in combination with a serpentine fibula with wings (Preloge, Gr. X/61), as well as two Type II Certosa fibulae and a solid ribbed bracelet (Preloge, Gr. 2/83).

Bronze wire was also used to make earrings of Type 8 (*fig. 122: 18 and fig. 123*) with loops.¹³⁹⁸ Two were found in Grave 13/43 at Preloge together with a small solid cast and ribbed bracelet, small amber and glass beads with protuberances as well as a small iron knife.¹³⁹⁹ For Graves 2/5 and 2/29 from Preloge, such earrings are inventoried among the grave goods, but were not listed by Pečnik. Also unreliable is Grave Group IV/41 from Preloge, the publication of which includes a serpentine fibula with a saddle-shaped bow and a double-kettledrum fibula, which are chronologically incompatible.

¹³⁹⁵ Tecco Hvala/Dular/Kocuvan 2004, T. 47A: 6,7, 121A: 1.

¹³⁹⁶ Hencken 1978, Figs. 20a, 38c, 49a, 158d,e, 341e; Tecco Hvala/Dular/Kocuvan 2004, T. 70A: 1,2, 73A: 1,2, 90E: 1, 96F: 3, 98B: 2, 102D: 1, 121B: 1, 133: 10,11; 147: 1-4.

¹³⁹⁷ Hencken 1978, Figs. 104a, 348c,d; Tecco Hvala/Dular/Kocuvan 2004, T. 62C: 1,2, 102B: 1,2.

¹³⁹⁸ Hencken 1978, Fig. 82k; Tecco Hvala/Dular/Kocuvan 2004, T. 19A: 1, 31B: 4, 78C: 1,2.

¹³⁹⁹ Glunz-Hüsken (2008, 46) ranked the examples from this grave among fibulae with a looped bow, the so-called *Schleifenbogenfibeln*, and dated them to Ha D1.

4.10.2 TRAKASTI UHANI ALI LASNI OBROČKI

Drugo skupino predstavljajo izdelki iz tanke bronaste pločevine, ki jih po obliki, dimenzijah, zaključkih in okrasu lahko delimo v več tipov in različic. Tip 5 združuje velike trakaste obroče, ki po premeru ustrezajo zapestnicam. Različica 5a (sl. 122: 5 in sl. 123) predstavlja primerke, ki so na enem delu zoženi oz. stisnjeni in imajo presegajoče konce, okrašeni pa

4.10.2 BAND EAR- OR HAIR-RINGS

These objects are made of thin sheet bronze and can be divided into several types and variants according to their form, size, decoration and manner of fastening. Type 5 comprises large band rings that have the same diameter as bracelets. Of those, examples of Variant 5a (fig. 122: 5 and fig. 123) have a constriction in the middle

Gom. / gr. Tum. / Gr.	Pokop / Burial rite	Spol / starost Sex / Age	Tip uhanov / Types of earrings	Št. uhanov / No. of earrings	Fibule / Fibulae	Ovratnice / Neckring	Steklene jagode / Glass beads	Jantar / Amber	Zapestnice / Bracelets	Nanožnice / Anklets	Diadem / Diadem	Scepter / Sceptre	Nož / Knife	Lončenina / Pottery	Bronasto posodje / Bronze vessels	Koščen tul / Bone tube	Vijčki / Spindle whorls	Šivanka / Needle
P 13/158	C	F	1	2	1									1				
P 13/110	S	?	1?+3	1+1														
P 13/98	S	F	3	1				x	1									
P 13/73	S	F		1		1												
P 13/93	S	?		2			2							1				
P 13/27	S	?		2										1				
P 13/15	S	F		2					x					1				
P 13/161	S	F		2		1			x									
V 2/6	S	I		2		4		br		6		x	x	3				1
P IV/2	?	F	4		1				2									
P II/9	?	?	5					x										
L V/3	S	F	4	1									1					
P 13/112	S	?		2														
P 2/83	S	F		2		2				1								
P X/61	S	F		3		1			x									
P 2/48	S	I		5a+1	2+2	1				3	16			2				
P VII/46	C	F	5a	x		x?			x	x			2					
P VII/40	S	F	5b	4	8	6	x	x	5	28							5	
P 13/101	C	F	5?	3	1								3	1				
P 2/54	S	F	6a	2	1		1	x										
P 2/84	S	F		2		1								1				
P IV/49	?	F		2		1												
P X/56	S	F		4				x										
P X/43	C	F		6		2								2				1
P 2/53	S	F		6a+7b	4	1			x									
P 13/24	C	?	6b	1									1					
V 2/12	S	I	6c	2	2		1	x								1	1	
P 4(IV)/2	S	F	6c	6	2			x	1									
P 13/88	S	F	6	4	1		2	3	2				1					
P 13/43	S	F	8	2			x		1			1						
P IV/41	?	F	8	2+4?	2			x					1					

Sl. 123: Struktura pridatkov v grobovih z bronastimi uhanimi in lasnimi obročki na Magdalenski gori.

Fig. 123: Structure of goods in the graves with bronze ear- and hair-rings at Magdalenska gora.

so z vrezanimi linijami.¹⁴⁰⁰ V grobu 2/48 s Prelog je bil par takih obročkov obešen na trortasto fibulo, medtem ko je imela pokojnica pri glavi žičnata uhana tipa 1. En primerek različice 5a je bil najden v žarnem grobu VII/46 na Prelogah skupaj z razlomljenimi gladkimi zapestnicami in nanožnicami. V žganem grobu 13/101 na Prelogah pa so bili v žari najdeni podobni, vendar masivnejši in vzdolžno nažlebljeni obročki, ki so bili izpostavljeni ognju.

Široke trakaste obroče, ki nimajo presegajočih zaključkov, temveč so se spenjali s kvačico, označujem kot različico **5b** (sl. 122: 7 in sl. 123).¹⁴⁰¹ Štiri take obroče je nosila vodilna predstavnica stopnje Stična, pokopana v grobu VII/40 s Prelog. En primerek je inventariziran v sklopu sočasnega žganega groba 13/163 s Prelog s podobno bogato opravo, vendar v prvotnem popisu najdb ni naveden. Tovrsten nakit je okrašen z vrezanim okrasom ali z iztolčenimi bunčicami in pikami.

Tip 6 predstavlja manjše trakaste obročke, ki so se spenjali s kvačico.¹⁴⁰² Eni imajo vrezan okras, tj. različica **6a** (sl. 122: 6),¹⁴⁰³ drugi so okrašeni z iztolčenimi bunčicami in pikami, tj. različica **6b** (sl. 122: 8),¹⁴⁰⁴ ali pa so narebreni, tj. različica **6c** (sl. 122: 9, 10).¹⁴⁰⁵ V opravah zasledimo po dva, štiri ali šest primerkov (sl. 123). V grobu X/43 s Prelog se omenja kačasta fibula, na kateri je viselo šest takih obročkov. V kombinaciji s kačastimi fibulami s sedlastim lokom ali s krilci ter z masivnimi narebreni zapestnicami nastopajo v grobovih 13/88 s Prelog in 2/12 z Voselce, medtem ko so bili v grobu 2/84 na Prelogah najdeni s certoško fibulo vrste V. Ob Pečnikovem kopanju na gomili 4 na Prelogah, ki jo je za njim dokončno raziskala vojvodinja Mecklenburška (gom. IV), je bilo v grobu 4/2 odkritih šest zelo majhnih trakastih obročkov (sl. 122: 10), po trije na vsaki strani lobanje; pokojnica je imela še jantarno ogrlico, drobno ločno fibulo z dvignjenim pestičastim gumbkom in eno certoško vrste II, na desni roki pa masivno narebreno zapestnico. Podoben tip uhana zasledimo še v žganem grobu 13/24 s Prelog, le da je bil ulit (sl. 122: 11) in spominja na svetolucijske primerke; najden je bil skupaj z rdečo kelihasto posodo, okrašeno s črnimi pasovi. K temu tipu uhanov bi morda lahko pripisali tudi en primerek iz groba 13/88.¹⁴⁰⁶

¹⁴⁰⁰ Hencken 1978, Fig. 267e; Tecco Hvala/Dular/Kocuvan 2004, T. 47A: 8,9, 101: 1-3.

¹⁴⁰¹ Hencken 1978, Fig. 260, 262t; Tecco Hvala/Dular/Kocuvan 2004, T. 123: 5, 147: 5,6.

¹⁴⁰² Hencken 1978, Fig. 334a-f, 346b; Tecco Hvala/Dular/Kocuvan 2004, T. 48B: 1-6, 48C: 2,3, 62E: 1,2, 65B: 2-7, 72B: 1, 95B: 3-10, 115B: 1-3, 134D: 1,2.

¹⁴⁰³ Preloge, gr. IV/49, X/43, X/56, 2/84, 13/144.

¹⁴⁰⁴ Preloge, gr. X/43, 2/54, 2/84, 13/88.

¹⁴⁰⁵ Voselca, gr. 2/12.

¹⁴⁰⁶ Tecco Hvala/Dular/Kocuvan 2004, T. 72B: 1, 95B: 3.

and overlapping ends, while their decoration consists of incised lines.¹⁴⁰⁰ A pair of such rings was found in Grave 2/48 at Preloge, threaded onto a three-knobbed fibula, while the deceased female had two wire earrings of Type 1 beside her head. One example of Variant 5a was found in urn Grave VII/46 at Preloge together with broken plain bracelets and anklets. The urn in cremation Grave 13/101 at Preloge revealed similar, though larger and longitudinally grooved rings that had been exposed to fire.

Wide band rings, the ends of which were not overlapping, but had a hook-and-eye closure, are marked as Variant **5b** (fig. 122: 7 and fig. 123).¹⁴⁰¹ Four such rings were worn by the leading female representative of the Stična phase buried in Grave VII/40 at Preloge. A further example is inventoried within contemporary cremation Grave 13/163 from Preloge, with similarly rich grave goods, though it is not mentioned in the original list of finds. This jewellery variant is decorated with incisions or embossed dots.

Type 6 represents small band rings with a hook-and-eye closure.¹⁴⁰² Their decoration consists of incisions, marked as Variant **6a** (fig. 122: 6),¹⁴⁰³ of embossed dots, marked as Variant **6b** (fig. 122: 8),¹⁴⁰⁴ or of ribbing, marked as Variant **6c** (fig. 122: 9, 10).¹⁴⁰⁵ They were found in sets of two, four or six (fig. 123). In Grave X/43 at Preloge, for example, a serpentine fibula was found with six examples threaded onto it. Type 6 rings were found in combination with serpentine fibulae with a saddle-shaped bow or with wings, as well as with solid ribbed bracelets in Graves 13/88 at Preloge and 2/12 at Voselca, while Grave 2/84 at Preloge revealed them with a Type V Certosa fibula. Six very small band rings (fig. 122: 10), three on each side of the skull, were found in Grave 4/2 by Pečnik, who excavated Tumulus 4 at Preloge that was later finished by the Duchess of Mecklenburg (she marked it as Tumulus IV). The female buried in this grave also had an amber necklace, a small bow fibula with a raised pistil-shaped knob and a Type II Certosa fibula, as well as a solid ribbed bracelet on her right arm. A similar, but cast type of earring was found in cremation Grave 13/24 at Preloge (fig. 122: 11); it is reminiscent of the Sveta Lucija examples. It was found together with a red goblet-shaped vessel decorated with black painted bands. A further example of this earring type might have been the one found in Grave 13/88.¹⁴⁰⁶

¹⁴⁰⁰ Hencken 1978, Fig. 267e; Tecco Hvala/Dular/Kocuvan 2004, T. 47A: 8,9, 101: 1-3.

¹⁴⁰¹ Hencken 1978, Figs. 260, 262t; Tecco Hvala/Dular/Kocuvan 2004, T. 123: 5, 147: 5,6.

¹⁴⁰² Hencken 1978, Figs. 334a-f, 346b; Tecco Hvala/Dular/Kocuvan 2004, T. 48B: 1-6, 48C: 2,3, 62E: 1,2, 65B: 2-7, 72B: 1, 95B: 3-10, 115B: 1-3, 134D: 1,2.

¹⁴⁰³ Preloge, Gr. IV/49, X/43, X/56, 2/84, 13/144.

¹⁴⁰⁴ Preloge, Gr. X/43, 2/54, 2/84, 13/88.

¹⁴⁰⁵ Voselca, Gr. 2/12.

¹⁴⁰⁶ Tecco Hvala/Dular/Kocuvan 2004, T. 72B: 1, 95B: 3.

4.10.3 VALJASTI UHANI
ALI LASNI OBROČKI

Najbolj pogosti so valjasti uhani oz. lasni obročki, ki se med seboj razlikujejo glede na razmerje med premerom in širino traku, pa tudi po okrasu. Primerke

4.10.3 CYLINDRICAL
EAR- OR HAIR-RINGS

The most frequent of all ear- or hair-rings are the cylindrical ones. They show different ratios between the diameter and the width of the band, but also differ in decoration. Examples in the shape of a short cylinder, which are mostly decorated with a simple geometric

Gom. / gr. Tum. / Gr.	Pokop / Burial rite	Spol / starost Sex / Age	Tip uhanov / Types of earrings	Št. uhanov / No. of earrings	Fibule / Fibulae	Igle / Pins	Steklene jagode / Glass beads	Jantar / Amber	Zapestnice / Bracelets	Nanožnice / Anklets	Prstan / Finger-ring	Scepter / Sceptre	Au nakit / Au jewellery	Obeski / Pendants	Pasne spone / Belts	Noži / Knives	Obročki / Rings	Brus / Whetstone	Lončenina / Pottery	Koščen tul / Bone tube	Vijčki / Spindle whorls		
P 2/16	S	?	7a	2																2			
P X/4	S	F		1	1		x	x												4		1	
P 2/27	?	F		2	1			x	1														
P 2/24	S	F		2	1		x	x															
P X/26	S	F		4	1		x																
V 2/8	S	F		6		1						x		x									
P VII/18	S	F	7b	1			x	x	1														
P VII/37	S	F		1				x	1														
VIII/17-18	S	F+A		1			x												1				
P 2/63	S	F		1	2			x	2		1												
P 13/87	S	F		1	1		x	x	2					x			Fe						
P 13/36	S	F+M?		2	2	1?	x	x	4	2		x			Fe	1		1	2				
P 13/152	S	F		2	1		x	x	2			x								6			
P 13/49	S	F		2	1			x	2											1			
P II/7	S	F		2	1						1												
P 2/66	S	I		2	1		x													1			
P 13/33	S	?		2				x												1			
P X/10	S	F		2				x	2											1			
V 2/16	?	I		x				x	2														
P IV/48	?	F		3				x	2														
P 13/159	S	F		4					2	2						1	Fe		1				
P 13/160	S	F		4				x	2											1			
P 2/65	S	I		4	1		x		2	2										1			
P 2/53	S	F		4	1			x															
P 2/52	S	F		4	3			x						x									
V 2/21	?	F		x	2		x	x	2														
V 2/9	?	F		6	2				2											1			
P 2/39	S	F		6	1+1?	1	x		2					x						1		4	
L V/2	S	F		4-6	3	2	x	x	2+2														
P 13/117	S	F		10	4		x	x	2+4	2+2				x									
P 13/97	S	F		7c	2			x	x	2	2		x							1			
P 13/96	S	F			2				x												1		5
P II/4	?	I?			2	1				1													
P IV/19	?	F	7		1																		

Sl. 124: Struktura pridatkov v grobovih z bronastimi uhani in lasnimi obročki na Magdalenski gori.
Fig. 124: Structure of goods in the graves with bronze ear- and hair-rings at Magdalenska gora.

v obliki nižjega valja, ki so povečini okrašeni s preprostim geometrijskim ornamentom iz vtisnjenih pik, sem označila za različico **7a** (sl. 122: 12, 13).¹⁴⁰⁷ Pojavljajo se v kompletih po dva, štiri ali šest primerkov (sl. 124), podobno kot trakasti obročki tipa 6. Zasledimo jih v kombinacijah z ogrlicami iz steklenih in jantarnih jagod ter s kačasto fibulo s sedlastim lokom ali s trakasto zanko, pa tudi s trakasto fibulo ali certoško vrste V. Različica **7b** združuje primerke v obliki izrazito visokega valja (sl. 122: 14–16),¹⁴⁰⁸ okras pa je sestavljen iz iztolčenih reber in pik, lahko je geometrijski ali figuralni. Magdalensko-gorske ženske so jih nosile običajno v parnem številu tja do deset primerkov (sl. 124). Pojavljajo se v kombinacijah z ogrlico, z dolgonožno ali s trakastimi fibulami, pa tudi s certoškimi vrst II, V in XIII ter s trortasto vrste VII oz. tipom Vinkov Vrh in z vzhodnoalpsko živalsko fibulo. Preostali obročasti nakit sestavljajo bodisi masivne zapestnice s presegajočimi konci ali votle zapestnice in nanožnice.

Različica **7c** je po obliki in okrasu enaka različici **7b**, le da ima na robovih pritrjene trikotne obeske iz bronaste pločevine (sl. 122: 17 in sl. 124).¹⁴⁰⁹ Par takih uhanov je imela pokojnica v grobu 13/97 s Prelog, ki je bila odeta v dragoceno ogrinjalo, pridani so ji bili sceptor in dvo-ploščični okrogli obeski ter jantarna ogrlica z več nizi in steklenimi ovnovimi glavicami, na rokah in nogah pa je imela votle obroče. V sklopu grobne celote II/4 s Prelog sta objavljena dva taka uhana skupaj z najmlajšo izpeljanko certoške fibule vrste VII ter z žičnatim spiralnim obročem, ki se je morebiti uporabljal kot zapestnica. Najlepše so izdelani primerki iz groba IV/19 na Prelogah, ki so bili speti skupaj z vzhodnoalpsko živalsko fibulo.

Uhani, obsenčniki ali lasni obročki so indikativni za žensko nošo, v dekliskih opravah jih zelo redko srečamo (sl. 123, 124). V starejšem halštatskem obdobju so nosile žičnate in velike trakaste uhane, dozdevno v vsakem ušesu po enega. Pozneje se uveljavijo manjši trakasti in valjasti obročki, ki so se spenjali s kvačico. Ti se pojavljajo v večjem številu po 4, 6 ali 10 primerkov, zato bi si jih še najlažje predstavljali kot okras na kitah oz. za spenjanje las, torej kot lasne obročke. Pojav valjastih uhanov oz. lasnih obročkov je pretežno omejen le na teritorij dolenjske halštatske skupnosti, najštevilneje pa so zastopani

¹⁴⁰⁷ Hencken 1978, Fig. 300c, 318a; Tecco Hvala/Dular/Kocuvan 2004, T. 20D: 1,2, 30A: 1,2, 30D: 1-4, 134A: 1-6.

¹⁴⁰⁸ Hencken 1978, Fig. 19a-e, 89a, 103a-d, 237a, 256b, 291a, 301a,c, 359a,b,e-h; Tecco Hvala/Dular/Kocuvan 2004, T. 37A: 1-7, 40B: 1-4, 48C: 4-7, 54C: 1,2, 55B: 1,2, 58A: 1-4, 75A: 1, 76: 1,2, 80B: 1, 95A: 1,2, 105: 1-24, 118: 1,2, 120B: 1-6; 122A: 1-4, 134B: 1-6, 137B: 1,2, 139B: 1-4, 148: 5,6.

¹⁴⁰⁹ Hencken 1978, Fig. 16a,b, 55b-e; Tecco Hvala/Dular/Kocuvan 2004, T. 99A: 2,3, 100: 14,15, 148: 1-4.

design made up of impressed dots, are marked as Variant **7a** (fig. 122: 12, 13).¹⁴⁰⁷ They appear in sets of two, four or six (fig. 124), similarly as the band rings of Type 6. They were found in combinations with necklaces of glass and amber beads, a serpentine fibula with a saddle-shaped bow and a band bow coiled into a loop, but also with a band bow fibula or a Type V Certosa fibula. Variant **7b** takes the form of a pronouncedly long cylinder (fig. 122: 14–16),¹⁴⁰⁸ whereby its decoration consists of embossed ribs and dots, but can also include figural and geometric motifs. The women from Magdalenska gora usually wore them in even numbers, up to ten examples (fig. 124). They were found in combinations with a necklace, a long-footed fibula, band bow fibulae, Types II, V and XIII Certosa fibulae, a three-knobbed fibula of Type VII (= Type Vinkov Vrh), an East Alpine animal-headed fibula, but also with solid bracelets with overlapping ends or hollow bracelets and anklets.

The difference between Variants **7b** and **7c** is only in that the latter has triangular pendants of sheet bronze attached along the edges (fig. 122: 17 and fig. 124).¹⁴⁰⁹ A pair of such earrings was found on the female buried in Grave 13/97 at Preloge, who wore a precious clothing and was buried with a sceptre, double-disc pendants, an amber necklace composed of several strings with glass ram's heads, as well as with hollow rings on her arms and legs. Two such earrings are published within Grave Group II/4 from Preloge together with the latest version of a Type VII Certosa fibula and with a spiral wire ring, the latter possibly used as a bracelet. The most beautifully made earrings of this variant are those found in Grave IV/19 at Preloge, which were bound together by an East Alpine animal-headed fibula.

Ear-, temple- or hair-rings are indicative of the female costume and were very rarely found in association with girls (fig. 123, 124). In the Early Hallstatt period, women wore wire as well as large band earrings, presumably one in each ear. Later, smaller band and cylindrical earrings, with a hook-and-eye closure, came into vogue. These were worn in sets of four, six or ten and could therefore easily be imagined as adornments in plaits or otherwise styled hair, therefore as hair-rings. The cylindrical ear- or hair-rings are mainly geographically limited to the territory of the Dolenjska Hallstatt community, most

¹⁴⁰⁷ Hencken 1978, Figs. 300c, 318a; Tecco Hvala/Dular/Kocuvan 2004, T. 20D: 1,2, 30A: 1,2, 30D: 1-4, 134A: 1-6.

¹⁴⁰⁸ Hencken 1978, Figs. 19a-e, 89a, 103a-d, 237a, 256b, 291a, 301a,c, 359a,b,e-h; Tecco Hvala/Dular/Kocuvan 2004, T. 37A: 1-7, 40B: 1-4, 48C: 4-7, 54C: 1,2, 55B: 1,2, 58A: 1-4, 75A: 1, 76: 1,2, 80B: 1, 95A: 1,2, 105: 1-24, 118: 1,2, 120B: 1-6; 122A: 1-4, 134B: 1-6, 137B: 1,2, 139B: 1-4, 148: 5,6.

¹⁴⁰⁹ Hencken 1978, Figs. 16a,b, 55b-e; Tecco Hvala/Dular/Kocuvan 2004, T. 99A: 2,3, 100: 14,15, 148: 1-4.

prav na Magdalenski gori, ki razgrinja tudi najpestrejšo ornamentiko med vsemi dolenskim primerki.¹⁴¹⁰

V obročkih iz spiralno zvite žice (tip 1 in 2) in v trakastih primerkih, ki so v sredini zoženi in imajo presegajoče konce (različica 5a), se zrcali žarnogrobiščna tradicija, ki se je ohranila vse tja do konca starejšega halštatskega obdobja (Ha C). V stopnji Stična je moč zaznati največ različnih tipov, nekateri tipi uhanov oz. lasnih obročkov, ki so takrat vzniknili (tipi 3, 6, 7a), so doživeli poln razcvet v stopnji kačastih fibul. V prvi fazi kačaste stopnje je dominiral tip 3, ki je predstavljal tipično prvino dolenske noše. Proti koncu te stopnje pa so se uveljavile garniture štirih ali šestih trakastih obročkov tipa 6, iz katerega se je razvil tip 7. Ta razvoj je stremel k čedalje višjim valjem. Za vse dolenske različice tipov 6 in 7 je značilno, da so se spenjali s kvačico z zunanje strani, zato je ta vselej ukrivljena navznoter. Prav po tem detajlu se razlikujejo od t. i. svetolucijskih uhanov, pri katerih je kvačica vtaknjena v luknjico od znotraj navzven, razen tega so svetolucijski uhani masivnejši, ker so bili uliti.¹⁴¹¹ Morda bi mednje lahko uvrstili magdalenskogorski fragmentirani primerek iz žarnega groba 13/24 s Prelog. Različica 7b, ki predstavlja obliko visokega valja, je značilna za dolensko žensko modo v času certoške stopnje. Ob koncu te stopnje in v zgodnji negovski fazi so uhanom dodali še trikotne obeske, v okrasu pa se pogosto pojavljajo upodobitve zajčkov (različica 7c).¹⁴¹² Trikotne obeske imajo tudi nekateri primerki uhanov iz bronaste žice, zvite v več pentelj (tip 8), ki v mlajši negovski fazi kažejo na odmik od halštatske toreutične tradicije.

numerously represented at Magdalenska gora. This site also shows the greatest variety in decoration.¹⁴¹⁰

The rings of spiral wire (Types 1 and 2) and band rings with a central constriction and overlapping ends (Variant 5a) reflect the Urnfield culture tradition, which was perpetuated until the end of the Early Hallstatt period (Ha C). The greatest range of ear- or hair-ring types is discernible in the Stična phase, whereby some of the types that first appeared during this phase (Types 3, 6, 7a) only became popular in the following, Serpentine Fibulae phase. The dominant rings of the first part of the Serpentine Fibulae phase were those of Type 3, which represented a typical element of the Dolenska costume. Towards the end of the phase the vogue was for sets of four or six band rings of Type 6, from which Type 7 later developed. The observable tendency was towards ever longer cylinders. It is also observable that rings of Types 6 and 7 in Dolenska were put on by inserting the hook from the outer side of the cylinder, as can be discerned from the hook that is always turned inwards. It is this detail that distinguishes them from the so-called Sveta Lucija earrings, where the hook was inserted from the inner side of the cylinder. A further difference is that the latter earrings were cast and thus thicker.¹⁴¹¹ A Sveta Lucija example might be seen in a fragmented earring from urn Grave 13/24 at Preloge. In the Certosa phase, the female costume of Dolenska was characterized by Variant 7b, in the shape of a long cylinder. At the end of the Certosa and the Early Negova phase earrings were added triangular pendants as well as decoration in the shape of animal figures, most often rabbits (Variant 7c).¹⁴¹² Triangular pendants can also be seen on some of the earrings of bronze wire twisted so as to form several loops (Type 8). These indicate a shift away from the Hallstatt toreutic tradition that took place in the Late Negova phase.

¹⁴¹⁰ Tecco Hvala 2007, 486, Fig. 5, 7–10.

¹⁴¹¹ *Ibid.*, 482, Fig. 4.

¹⁴¹² Teržan 1976, T. 4:12, 8: 4-7, 14: 6-9, 66: 4; Hencken 1978, Fig. 55b,c,e; Turk 2005, 73 ss, sl. 114–117; Frey 2007, 782 ss, Abb. 3.

¹⁴¹⁰ Tecco Hvala 2007, 486, Figs. 5, 7–10.

¹⁴¹¹ *Ibid.*, 482, Fig. 4.

¹⁴¹² Teržan 1976, T. 4:12, 8: 4-7, 14: 6-9, 66: 4; Hencken 1978, Fig. 55b,c,e; Turk 2005, 73 ff, figs. 114–117; Frey 2007, 782 ff, Abb. 3.

4.11 SCEPTRI, DIADEM IN ZLAT NAKIT

Med ženske oz. dekliške insignije spadajo okrašene paličice z obeski, t. i. sceptri, ter diadem in zlat nakit (sl. 125). O njih so že napisane podrobne študije,¹⁴¹³ zato se bom omejila na prikaz oprav z Magdalenske gore (sl. 127) ter na komentarje k dosedanjim ugotovitvam.

4.11.1 SCEPTRI

Največ sceptrov z Magdalenske gore je izdelanih iz cevasto ukrivljene bronaste pločevine (sl. 125: 6–12). Narejeni so na podoben način, kot so izdelovali votle zapestnice in ovratnice ali valjaste lasne obročke. Na vrhu so zaključeni z okroglo ploščico, ki ima ob robu luknjice, v katere so vdete verižice s trikotnimi obeski.¹⁴¹⁴ Ornamentirani so z vrezanim okrasom, en primerek je bil stožčasto oblikovan in ima pritrjene pločevinaste bobenčke, dokumentiran pa je le v risbi (sl. 126: B).¹⁴¹⁵ Razen izdelkov iz bronaste pločevine, ki so bili verjetno nataktnjeni na leseno palico, je znan tudi polno ulit trirogeljni obesek z visečimi okraski na verižicah (sl. 125: 5).¹⁴¹⁶

Lega in kontekst. Scepter, ki nastopa med pridatki groba X/75 s Prelog (sl. 125: 11), je po Goldbergovih navedbah ležal skupaj z obročkom v obliki sončnega kolesa na levi strani prsnega koša pokojnice, ki je imela na prsih kačasto fibulo in iglo, na nadlahtnicah narokvici, okoli vratu ogrlico iz modrih in jantarnih jagod, ob sencih pa dva uhana. Objavljena grobna celota vsebuje še vrsto drugih predmetov, ki jih Goldberg ne omenja. O grobu I/1 s Prelog, ki so mu domnevno pripadali trije kosi cevasto ukrivljene pločevine z okrasom (sl. 125: 6, 7), ni nikakršnih podatkov.

Druge kultne paličice so bile najdene v okviru Pečnikovih izkopavanj za ljubljanski in dunajski muzej. Trirogeljni obesek s trikotnimi in raznimi drugimi okraski (sl. 125: 5) je pripadal deklici z Vosele (2/6), ki je imela še diadem z bronastim trikrakim okraskom (sl. 125: 4), niz bronastih jagod, štiri fibule (dve čolničasti, eno sanguisuga in eno dvortasto), dva uhana tipa 3 ter tri gladke in tri narebrenne zapestnice. Pridane so ji bile tri glinaste posode (trodelna posoda v obliki rač, estenska situla in menda še ena rdeča skodelica) ter vijček. Grobna celota 2/c s Prelog je samo delno rekonstruirana; v grobu naj bi bila po Pečnikovi oceni pokopana od osem do deset let

¹⁴¹³ Za kultne palice glej Stare V. 1973c; za zlato okrasje in diademe glej Guštin/Preložnik, 2005 s citirano starejšo literaturo ter Teržan/Hellmuth 2008; Hellmuth 2008.

¹⁴¹⁴ Hencken 1978, 79, Fig. 3, 359m,q; Tecco Hvala/Dular/Kocuvan 2004, T. 76: 25,26, 148: 14-16.

¹⁴¹⁵ Tecco Hvala/Dular/Kocuvan 2004, sl. 38.

¹⁴¹⁶ *Ibid.*, T. 133: 8.

4.11 SCEPTRES, DIADEMS AND GOLD JEWELLERY

Women's or girl's insignia include sceptres, as well as diadems and gold jewellery (fig. 125). These kinds of objects have already been discussed in numerous studies,¹⁴¹³ wherefore their presentation here will be limited to their contexts at Magdalenska gora (fig. 127).

4.11.1 SCEPTRES

Most sceptres from Magdalenska gora are made of tubular bronze sheets (fig. 125: 6–12), in a similar manner as the hollow bracelets and torques or the cylindrical hair-rings. The tube is topped by a round plate with holes along the edge, through which chains with triangular pendants are attached.¹⁴¹⁴ They are decorated with incised decoration. One example was also shaped as a cone with cylindrical pendants hanging from it; it is documented in drawing only (fig. 126: B).¹⁴¹⁵ Apart from the objects made of sheet bronze, which were probably stuck onto a wooden rod, one was also cast solid. It is a pendant with three prongs and further pendants on chains hanging from it (fig. 125: 5).¹⁴¹⁶

Position and context. Most of the sceptres were unearthed during Pečnik's excavations for the museums in Ljubljana and Vienna. A three-pronged pendant with triangular and other ornaments (fig. 125: 5) belonged to a girl buried at Vosele (2/6), who also had a diadem with a bronze three-pointed ornament (fig. 125: 4), a string of bronze beads, four fibulae (two boat, one leech and one two-knobbed), two earrings of Type 3, three plain and three ribbed bracelets, three clay vessels (tripartite vessel in the shape of ducks, an Este type situla, reportedly a red cup) and a spindle whorl. Another sceptre was reportedly found in Grave 2/c at Prelog, whereby its grave group could only be partially reconstructed. According to Pečnik, the grave contained the remains of a richly accoutred 8- to 10-year-old girl, buried with a fibula in the shape of a three-horse chariot, a fibula with a spiky glass overlay and another fibula that Pečnik termed of a rare kind with round ornaments. The latter could not be identified among museum finds and neither could the earrings, bracelets, anklets, sceptre and three red vessels, one of them reportedly decorated with black painted bands (possibly an Este type situla). The sceptre,

¹⁴¹³ For scepters see Stare V. 1973c; for gold jewellery and diadems see Guštin/Preložnik, 2005 with references and also Teržan/Hellmuth 2008; Hellmuth 2008.

¹⁴¹⁴ Hencken 1978, 79, Figs. 3, 359m,q; Tecco Hvala/Dular/Kocuvan 2004, T. 76: 25,26, 148: 14-16.

¹⁴¹⁵ Tecco Hvala/Dular/Kocuvan 2004, Abb. 38.

¹⁴¹⁶ *Ibid.*, T. 133: 8.

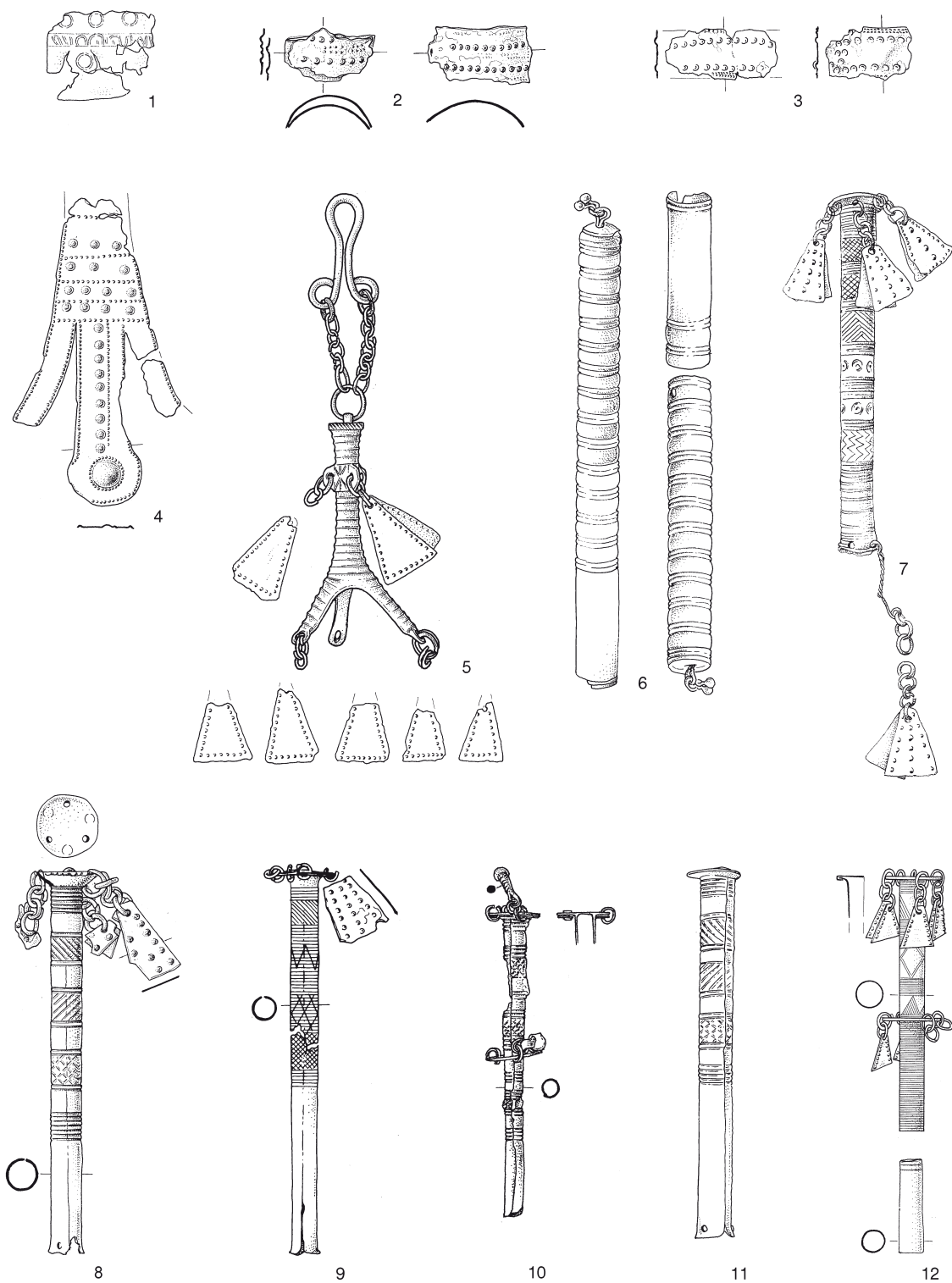

Sl. 125: Diadem, zlat oz. pozlačen nakit ter sceptri z Magdalenske gore. 1 = zlato; 2, 3 = bron s pozlato; 4-12 = bron. M. = 1:2.
 Fig. 125: Diadem, gold or gilded jewellery and sceptres from Magdalenska gora. 1 = gold; 2, 3 = gilded bronze; 4-12 = bronze.

Scale = 1:2.

1 - Preloge, gr. 13/117; 2 - Preloge, gr. 2/a; 4, 5 - Voselca, gr. 2/6; 6, 7 - Preloge, gr. I/1;
 3, 8-10 - najdbe brez znanih grobnih celot v NMS / finds without preserved grave group in the NMS;
 11 - Preloge, gr. X/75; 12 - Preloge, gr. 13/36.

A

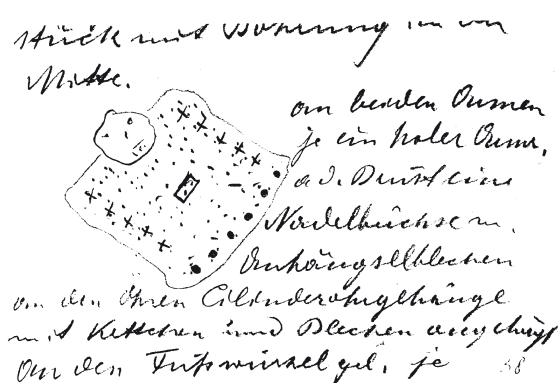

B

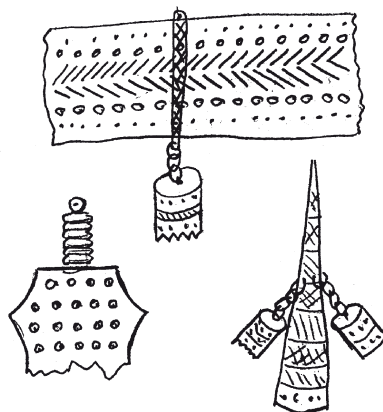

Sl. 126: Brattinovi skici groba 13/97 (A) in scepra iz groba 13/152 (B).
Fig. 126: Brattina's sketch of Grave 13/97 (A) and of the sceptor from Grave 13/152 (B).

stara deklica v bogati opravi s fibulo v obliki trovprege ter eno jezevko; menda je imela še eno fibulo "redke vrste z okroglimi okraski", ki nam je ni uspelo identificirati, prav tako ne uhanov, zapestnic, nanožnic, scepra in treh rdečih posod, od katerih naj bi bila ena okrašena s črnimi pasovi (morda je šlo za estensko situlo). Zelo verjetno ji je pripadal eden izmed treh sceptrov, ki so inventarizirani v zbirki muzeja v Ljubljani (sl. 125: 8–10).

V zbirki dunajskega muzeja je ohranjen scepter iz groba 13/36 na Prelogah (sl. 125: 12), kjer je bil najden skupaj z dvema certoškima fibulama vrste V, ogrlicami iz steklenih in jantarnih jagod, votlim obročastim okrasjem ter nekaterimi moškimi pridatki, kot so železna rombična pasna spona, brus in nož. Cevaste paličice oz. *Nadelbüchse* se omenjajo še v opisih grobov 13/97, 13/152 s Prelog in 2/8 z Voselce, vendar se niso ohranile. Med pridatke groba 2/8 z Voselce je poleg scepra, šestih valjastih uhanov in igle z zankasto uvito glavico spadal bronast obesek v obliki amforice. Opravo pokojnice v grobu 13/97 s Prelog pa je Brattina skiciral in opisal v svojem terenskem dnevniku (sl. 126: A). Imela je: "[...] auf schwarzem Gewebe viele 100 derte von kl Glasperlen, verschiedener Form und Farbe in der Skizze sind die kl Punkte kl Glasringelchen die großen Punkte Widerköpfe die Kreutze sind Br Anhängsel und ein Bernsteinstück mit Bohrung in der Mitte. An beiden Armen je ein holer Armr. a. d. Brust eine Nadelbüchse m Anhängselblechen an den Ohren Cylinderohrgehänge mit Kettchen und Blechen aufgehängt. An den Fußwurzeln gel. je ein Füßring, hol. zu Füßen ein schwarzes Gefäß mit Buckeln."¹⁴¹⁷ Ob tem velja izpostaviti, da sta zapestnici po velikosti sodeč otroški.

Iz njegove skice in opisa je znana tudi kulna palica stožčaste oblike iz groba 13/152 na Prelogah (sl. 126: B). Ležala je menda ob desnem kolku 170 cm dolgega skeleta, v tulcu so bili še ostanki lesa; pri kolkih je bila najdena bronasta pločevina s cilindričnimi obeski, ob

however, is very probably one of the three inventoried at the museum in Ljubljana (fig. 125: 8–10).

The museum in Vienna holds the sceptor found in Grave 13/36 at Preloge (fig. 125: 12) together with two Type V Certosa fibulae, necklaces of glass and amber beads, hollow ring jewellery and male attributes, namely an iron rhombic belt clasp, a whetstone and a knife. The tubular rods or *Nadelbüchse* in German, are also mentioned in Graves 13/97, 13/152 from Preloge and 2/8 from Voselca, though they have not been preserved. The latter grave from Voselca reportedly revealed, besides the sceptor, six cylindrical earrings, a roll-headed pin and a bronze amphora-shaped pendant. For the female buried in Grave 13/97 at Preloge, Brattina drew a sketch and wrote in his field diary (fig. 126: A) that she had, "[...] auf schwarzem Gewebe viele 100 derte von kl Glasperlen, verschiedener Form und Farbe in der Skizze sind die kl Punkte kl Glasringelchen die großen Punkte Widerköpfe die Kreutze sind Br Anhängsel und ein Bernsteinstück mit Bohrung in der Mitte. An beiden Armen je ein holer Armr. a. d. Brust eine Nadelbüchse m Anhängselblechen an den Ohren Cylinderohrgehänge mit Kettchen und Blechen aufgehängt. An den Fußwurzeln gel. je ein Füßring, hol. zu Füßen ein schwarzes Gefäß mit Buckeln."¹⁴¹⁷ It should be added that, judging by their size, the bracelets probably belonged to a child.

Known only from Pečnik's sketch and description is also the conical sceptor from Grave 13/152 at Preloge (fig. 126: B). It was reportedly found beside the right hip of a 170cm tall skeleton and revealed remains of wood inside the rod's tube. Also beside the hips were the remains of a bronze sheet objects with cylindrical pendants, an ornamental pendant was found beside the right arm and six vessels were placed at her feet (two on a high and two on a low foot, one of them reportedly containing a wooden vessel with a coat of sheet bronze),

¹⁴¹⁷ Ibid., 67 s, sl. 33.

¹⁴¹⁷ Ibid., 67 f, Abb. 33.

Gom. / gr. Tum. / Gr.	Pokop / Burial rite	Spol / starost Sex / Age	Diadem / Diadem	Scepter / Sceptre	Au nakit / Au jewellery	Fibule / Fibulae	Igle / Pins	Uhani / Earrings	Steklene jagode / Glass beads	Jantar / Amber	Zapestnice / Bracelets	Nanožnice / Anklets	Pasne spona / Belts	Nož / Knife	Brus / Whetstone	Lončnina / Pottery	Bronasto posodje / Bronze vessels	Lesena posoda / Wooden ware	Vijčki / Spindle whorls
V 2/6	S	I	br	x		4		2	br		6					3			1
P 13/97	S	I?		x		1?		2	x	x	2	2				1			
P 2/c	S	I		x		3		2	x	x	4	2				3			
P 13/36	S	F+M?		x		2		2	x	x	4	2	Fe	1	1	1			
P 13/152	S	F		x		1		2	x	x	2		Fe + br			6		1	
P X/75	S	F		x		1	1	4	x	x	2								
V 2/8	S	F		x			1	6											
P 13/117	S	F			x	4		10	x	x	6	4							
P 2/a	S	F			x	8			x	x	4					1	2		
P X/72	S	F			x	2				x	5								
P 2/n	S	F			x					x	2								
L V/32	S	F			x					x									2

Sl. 127: Struktura pridatkov v grobovih s sceptri, diademom in zlatim okrasjem na Magdalenski gori.
Fig. 127: Structure of goods in the graves with sceptres, a diadem and gold jewellery at Magdalenska gora.

desni roki pa okrasni obesek. K nogam je bilo položenih šest posod (dve na visoki in dve na nižji nogi, v eni je bila baje lesena skodelica, okovana z bronasto pločevino), medtem ko sta bili železna pravokotna pasna spona in kačasta fibula zataknjeni med dve posodi.

Razširjenost in časovni okvir. Polno ulit rogljičast obesek z okraski iz groba 2/6 na Voselci lahko po spremljajočih najdbah postavimo na konec stopnje Stična 2. Sorodne predmete bi lahko prepoznali v masivnih okrašenih paličastih obeskih s pritrjenimi okraski med najdbami iz Stične,¹⁴¹⁸ Velikega Vinjega vrha (Šmarjete)¹⁴¹⁹ in Rovišča,¹⁴²⁰ pa tudi iz bolj oddaljenih krajev zahodne Panonije (Kisravazd in Beremend).¹⁴²¹ Primerek z Voselce ima najboljšo analogijo v najdbi iz depoja Kisravazd, ki je vseboval 31 čolničastih fibul in 10 zapestnic, 15 bronastih pravokotnih lamel, okrašenih z iztolčenimi pikami in bunčicami ali s stiliziranimi petelinčki oz. pticami, ter obesek v obliki sončnega koleščka; ti predmeti so bili deponirani v glinasti posodi.¹⁴²²

while an iron rectangular belt clasp and a serpentine fibula were wedged between two of the vessels.

The sceptre from female Grave X/75 at Preloge (fig. 125: 11) was, according to Goldberg, found on the left side of the chest of the deceased together with a sun-wheel pendant. Also lying on her chest was a serpentine fibula and a pin, while an armlet was found on each of her upper arms, a necklace of blue and amber beads around her neck and two earrings at her temples. The publication of this grave group further lists a number of goods not mentioned by Goldberg. Further three decorated pieces of tubular sheet metal are reported in connection with Grave I/1 from Preloge (fig. 125: 6, 7), though no other information is available.

Distribution and time frame. The solid cast three-pronged pendant with ornaments from Grave 2/6 at Voselca can be dated to the end of the Stična 2 phase on the basis of associated grave goods. Remains of similar objects could be observed among the finds from Stična,¹⁴¹⁸ Veliki Vinji vrh (Šmarjeta)¹⁴¹⁹ and Rovišče,¹⁴²⁰ but also from more distant sites in western Pannonia (Kisravazd and Beremend).¹⁴²¹ The closest analogy for the example

¹⁴¹⁸ Stična, gr. 48/1: Gabrovec et al 2006, T. 1: 1-2.

¹⁴¹⁹ Stare V. 1973a, T. 34: 1.

¹⁴²⁰ Gr. 1-1883/9: Dular J. 2003, T. 66: 1.

¹⁴²¹ Fekete 1973, Abb. 3: 29, 2-7, T. 43-50; Jerem 1973, Abb. 8: 16, 17.

¹⁴²² Fekete 1973, 341 ss.

¹⁴¹⁸ Stična, gr. 48/1: Gabrovec et al. 2006, T. 1: 1-2.

¹⁴¹⁹ Stare V. 1973a, T. 34: 1.

¹⁴²⁰ Gr. 1-1883/9: Dular J. 2003, T. 66: 1.

¹⁴²¹ Fekete 1973, Abb. 3: 29, 2-7, T. 43-50; Jerem 1973, Abb. 8: 16, 17.

Na teritoriju dolenske halštatske skupnosti so bolj pogoste cevaste paličice, ki se zaključujejo z okroglo ploščico in so okrašene z vrezi.¹⁴²³ Največ primerkov je znanih z Velikega Vinjega vrha (Šmarjete) in Magdalenske gore, v glavnem pa pripadajo grobovom iz časa certoških fibul, v katerih srečamo še jagode v podobi ovnovih glav (Brezje, gr. 7/1), obeske v obliki sončnega kolesa (Libna) ali pa fibulo z lokom v obliki račke (Rovišče, gr. 1/2) ter druge okraske simbolnega značaja, predvsem pa jantar. Analogije za stožčasto oblikovan predmet najdemo na Vačah¹⁴²⁴ in v Novem mestu, kjer predstavlja spodnji zaključek sceptra, medtem ko je zgornji del narejen iz cevaste pločevine.¹⁴²⁵

Tovrstnim dolenskimi sceptrom je zelo podoben primerek iz Beremenda, kjer je bil najden v ženskem grobu skupaj s certoškima fibulama vrste V, srebrnimi enozankastimi ločnimi fibulami s kvadratno sedlasto nogo, srebrnimi tordiranimi obročki, steklenimi jagodami in pasnimi okovi.¹⁴²⁶ Znan je še iz Szentlőrinc, iz žganega groba z ostanki štiri- ali petletne deklice.¹⁴²⁷ Na drugi strani so dolenske kultne palice po obliki in načinu izdelave sorodne primerkom iz grobišč v Este¹⁴²⁸ in Padovi,¹⁴²⁹ ki pa so večinoma ornamentirani z drugačnimi iztolčenimi motivi, vendar med njimi zasledimo tudi take, ki bi jih lahko primerjali z nekaterimi magdalenskogorskimi najdbami (*sl.* 125: 6).¹⁴³⁰ V estenski kulturi so se kultne palice iz cevasto ukrivljene pločevine pojavile že v času Este IIIB1/B2 po Peroniju (= konec stopnje II-pozno po Freyu), največ primerkov je znanih iz stopnje Este IIIB2 (= stopnja II/III), obdržijo pa se še v stopnji IIID1 (= III-srednje),¹⁴³¹ tj. v času certoških fibul na Dolenskem.

¹⁴²³ *Brezje*, gr. 7/1: Kromer 1959a, T. 20: 5; *Dobrnič*: Stare V. 1973b, T. 8: 9; *Kosmatec pri Preski*, gr. 10: Guštin 1974b, T. 13: 6,7; *Libna*: id. 1976, T. 65; *Mokronog*: neobjavljeno, NMS inv. št. P 6237; *Novo mesto-Znančeve njive*, gr. 2/19, *Kapiteljska njiva*, gr. 29/2: Knez 1986, T. 21: 1; Križ et al. 2009, 122, 123; *Rovišče*, gr. 1/2: Stare V. 1962–1963, T. 1: 1, 6: 16; *Stična*: Gabrovec et al. 2006, T. 187: 59; *Vače*: neobjavljeno, NHMW inv. št. 34847; *Veliki Vinji vrh (Šmarjeta)*: Stare V. 1973a, T. 33: 4-12; *Vinkov vrh*: Stare V. 1964–1965, T. 5: 9.

¹⁴²⁴ Neobjavljeno, NHMW inv. št. 8247.

¹⁴²⁵ *Kapiteljska njiva*, gr. 29/2: Križ et al. 2009, 122.

¹⁴²⁶ Jerem 1973, Abb. 7: 1.

¹⁴²⁷ Jerem 1968, 187, Fig. 14, 24: 34/2, Pl. 39: 5.

¹⁴²⁸ *Casa di Ricovero*, gr. 3, 159, 171, 204, 212 ter *sporadična najdba*; *Casa Mulletti Prosdocimi*, gr. 259; *Casa Alfonsi*, gr. 13, 24; *Villa Benvenuti*, gr. 78, 79, 83, 99, 122, 126: Chieco Bianchi/Calzavara Capuis 1985, T. 69: 29, 85: 6, 119: 17, 137: 51, 214: 23, 249: 13, 262: 5,6, 263: 7, 274: 11, 295: 205; Calzavara Capuis/Chieco Bianchi 2006, T. 51: 47, 54: 29,30, 65: 38,39, 97: 22, 148: 21, 180: 26,27.

¹⁴²⁹ Gambacurta 2005, 354, Fig. 13: 54.

¹⁴³⁰ Glej npr. Chieco Bianchi/Calzavara Capuis 1985, T. 156: 51, 274: 11, 295: 205; Chieco Bianchi 1987, 214, Fig. 33: 101, ter primerke z najdišča *Montebello Vicentino*: Bondini 2005, 222, Fig. 5: 1-3.

¹⁴³¹ Frey 1969, T. 10: 11, 13: 50,51, 17: 16; Calzavara Capuis/Chieco Bianchi 2006, 485 ss.

from Voselca can be found in the Kisravazd hoard. The latter consisted of 31 boat fibulae, 10 bracelets, 15 rectangular plates of sheet bronze decorated with embossed dots, cocks or birds, and a sun-wheel pendant; all these objects were placed inside a clay vessel.¹⁴²²

More common in Dolenska were the tubular rods terminating in a round plate and decorated with incisions.¹⁴²³ The highest number of such objects was unearthed at Veliki Vinji vrh (Šmarjeta) and Magdalenska gora. Most of them belonged to graves from the Certosa phase. Besides sceptres, they contained beads in the shape of ram's heads (Brezje), sun-wheel pendants (Libna), a fibula with a duck-shaped bow (Rovišče) and other ornaments of a symbolic significance and, most often, amber. The analogies for the conical object, on the other hand, can be found at Vače¹⁴²⁴ and Novo mesto, the latter representing the bottom terminal of a sceptre, while the upper part is made of tubular sheet metal.¹⁴²⁵

Very similar to the sceptres from Dolenska is an example from Beremend, found in a female grave together with two Type V Certosa fibulae, silver single-looped bow fibulae with a square-concave foot, small and twisted silver rings, glass beads and belt fittings.¹⁴²⁶ Another analogy comes from Szentlőrinc, from a cremation burial of a 4- or 5-year-old girl.¹⁴²⁷ On the other hand, the sceptres from Dolenska are also similar to the examples from the cemeteries at Este¹⁴²⁸ and Padova.¹⁴²⁹ The latter are mostly decorated with embossed motifs different from those in Dolenska, but do include some examples that could be compared to the finds from Magdalenska gora (*fig.* 125: 6).¹⁴³⁰ Sceptres made of tubular sheet metal appeared within the Este culture as early as Este IIIB1/

¹⁴²² Fekete 1973, 341 ff.

¹⁴²³ *Brezje*, Gr. 7/1: Kromer 1959a, T. 20: 5; *Dobrnič*: Stare V. 1973b, T. 8: 9; *Kosmatec near Preska*, Gr. 10: Guštin 1974b, T. 13: 6,7; *Libna*: id. 1976, T. 65; *Mokronog*: unpublished, NMS Inv. No. P 6237; *Novo mesto-Znančeve njive*, Gr. 2/19, *Kapiteljska njiva*, Gr. 29/2: Knez 1986, T. 21: 1; Križ et al. 2009, 122, 123; *Rovišče*, Gr. 1/2: Stare V. 1962–1963, T. 1: 1, 6: 16; *Stična*: Gabrovec et al. 2006, T. 187: 59; *Vače*: unpublished, NHMW Inv. No. 34847; *Veliki Vinji vrh (Šmarjeta)*: Stare V. 1973a, T. 33: 4-12; *Vinkov vrh*: Stare V. 1964–1965, T. 5: 9.

¹⁴²⁴ Unpublished, NHMW Inv. No. 8247.

¹⁴²⁵ *Kapiteljska njiva*, Gr. 29/2: Križ et al. 2009, 122.

¹⁴²⁶ Jerem 1973, Abb. 7: 1.

¹⁴²⁷ Jerem 1968, 187, Figs. 14, 24: 34/2, Pl. 39: 5.

¹⁴²⁸ *Casa di Ricovero*, Gr. 3, 159, 171, 204, 212 and a stray find; *Casa Mulletti Prosdocimi*, Gr. 259; *Casa Alfonsi*, Gr. 13, 24; *Villa Benvenuti*, Gr. 78, 79, 83, 99, 122, 126: Chieco Bianchi/Calzavara Capuis 1985, T. 69: 29, 85: 6, 119: 17, 137: 51, 214: 23, 249: 13, 262: 5,6, 263: 7, 274: 11, 295: 205; Calzavara Capuis/Chieco Bianchi 2006, T. 51: 47, 54: 29,30, 65: 38,39, 97: 22, 148: 21, 180: 26,27.

¹⁴²⁹ Gambacurta 2005, 354, Fig. 13: 54.

¹⁴³⁰ See, for example Chieco Bianchi/Calzavara Capuis 1985, T. 156: 51, 274: 11, 295: 205; Chieco Bianchi 1987, 214, Fig. 33: 101, and examples from *Montebello Vicentino*: Bondini 2005, 222, Fig. 5: 1-3.

4.11.2 DIADEM IN ZLAT NAKIT

Bronast trikraki okrask v obliki puščice ali drevesa (sl. 125: 4) je spadal, kot rečeno, k opravi deklice z Voselca (2/6),¹⁴³² medtem ko je zlata lamela z iztolčenim okrasom (sl. 125: 1) pripadala menda 185 cm visoki ženski, pokopani v grobu 13/117. V Brattinovem terenskem dnevniku lahko preberemo, da je imela “[...] *um Hals u Brust ein mit zahlreichen Glas u Bernsteinperlen besetztes Gewebe welches überdies mit dünnen Goldplättchen welche feine Verzierung zeigen benäht war, und von 4 kl Fibeln am Kleide gehalten wurde.*”¹⁴³³ Še razkošneje je bila po Rutarjevih besedah opravljena nenavadno velika ženska v grobu, ki ga je odkril Pečnik na zahodnem robu gomile 2 na Prelogah. Črnologar in Pečnik sta o njej med drugim zapisala, da je imela perlic za poldrugi liter oz. “[...] *nad 4000 steklenih korald ter bronastih okraskov, našitih po obleki, na vratu pa obešenih okoli 80 jantarjevih jagod, dalje 4 fibule, 4 bronaste zapestnice, med njimi 2 prav lepi votli, pozlačene bronaste uhane in veliko črno posodo. Na koncu nog sta ji ležali 2 bronasti situli (kotla), ki bi imeli zelo veliko ceno, ako bi bili bolje ohranjeni.*”¹⁴³⁴ Žal grobna celota ni ohranjena, prav tako ne drobno okrasje, uvezeno v oblačilo. Na osnovi teh pričevanj smo lahko prepoznali le bronasti situli (eno krasi žarnogrobiščni motiv račk in koncentričnih krožcev, drugo pa figuralni prizori v štirih frizih) ter okrasje s pozlato in jantarno ogrlico (sl. 125: 2, 3); grob nosi našo oznako 2/a. Zlato omenja Pečnik tudi v grobu 2/n, ki se je menda nahajal v sredini gomile in je bil obdan s kamenjem, v njem je bila lesena krsta z okostjem ženske, ki naj bi po njegovih besedah imela dve bronasti zapestnici ter “[...] *ein schönes Kopftuch verziert mit Gold und Korallen [...] und haben den schönen Tuch am ende der füße geworfen.*”¹⁴³⁵ Oblačilo, pošito z raznobarnimi perlicami, je nosila tudi predstavnica iz gomile 13, pokopana v grobu 13/97.¹⁴³⁶ Čeprav se te oprave niso ohranile, lahko vseeno rečemo, da je šlo za ene najlepših ženskih kostumov na Dolenjskem iz časa certoske stopnje. Zlati lističi se omenjajo še v grobovih V/32 na Laščiku in X/72 na Prelogah. V grobu X/72 naj bi bili najdeni skupaj z veliki jantarnimi jagodami pri kolenih pokojnice, ki je med drugim imela čolničasto in kačasto fibulo.¹⁴³⁷

Kot sta pokazala Guštin in Preložnik, se je zlato okrasje pojavilo v Beli krajini in ob spodnjem toku Krke že v stopnji Podzemelj 2, pozneje pa se je razširilo v visokih družbenih krogih domala v vsej dolenjski skupnosti. Nakazala sta dve možni vplivni območji, od koder je dolenjska družba morebiti sprejela te navade –

B2 after Peroni (= end of Phase II-Late after Frey). The highest number of them date to Este IIIB2 (= Phase II/III) and some also to IIID1 (= III-Middle),¹⁴³¹ that is the Certosa phase in Dolenjska.

4.11.2 DIADEM AND GOLD JEWELLERY

The bronze three-pointed pendant in the shape of either an arrow or a tree (fig. 125: 4) was buried, as said above, with a girl at Voselca (2/6).¹⁴³² Also found was a gold sheet plate with embossed decoration (fig. 125: 1) that belonged to a reportedly 185cm tall woman buried in Grave 13/117. In his field diary, Brattina wrote that the latter had, “[...] *um Hals u Brust ein mit zahlreichen Glas u Bernsteinperlen besetztes Gewebe welches überdies mit dünnen Goldplättchen welche feine Verzierung zeigen benäht war, und von 4 kl Fibeln am Kleide gehalten wurde.*”¹⁴³³ Even richer accoutrements were described by Rutar for the unusually tall woman buried in a grave that Pečnik found at the western edge of Tumulus 2 at Preloge. Črnologar and Pečnik wrote that she was covered by a litre and a half of beads, but also over 4000 glass beads and bronze ornaments sewn onto her dress, roughly 80 amber beads strung around the neck, four fibulae, four bronze bracelets, among them two beautiful hollow ones, gilded bronze earrings and a large black vessel. At her feet, they reported finding two bronze situlae, adding that they would fetch a high price if better preserved.¹⁴³⁴ Unfortunately, neither the grave group as a whole nor the small ornaments sewn onto the dress have been preserved; we were only able to identify the two bronze situlae (one decorated with the Urnfield culture motif of ducks and concentric circles, and the other with a figural scene in four friezes), the gilded ornaments and the amber necklace (fig. 125: 2, 3). The grave is marked 2/a. Pečnik also mentions gold in Grave 2/n, which was reportedly found in the centre of the tumulus. The grave was surrounded by stones and contained a wooden coffin with a skeleton of a woman, which had two bronze bracelets and, “[...] *ein schönes Kopftuch verziert mit Gold und Korallen [...] und haben den schönen Tuch am ende der füße geworfen.*”¹⁴³⁵ A dress with small glass beads of various colours sewn onto it was also worn by a female representative of Tumulus 13, buried in Grave 13/97.¹⁴³⁶ These objects have not been preserved, but we can nevertheless say that the women that wore them were among the most beautifully dressed in all Dolenjska in the Certosa phase. Gold leaves are also

¹⁴³² Tecco Hvala/Dular/Kocuvan 2004, T. 133: 7.

¹⁴³³ Ibid., 71, T. 105: 26.

¹⁴³⁴ Ibid., 28, T. 7: 1, 2, 148: 1,2.

¹⁴³⁵ Ibid., 32.

¹⁴³⁶ Ibid., 67 s, sl. 33.

¹⁴³⁷ Hencken 1978, 38,79.

¹⁴³¹ Frey 1969, T. 10: 11, 13: 50,51, 17: 16; Calzavara Capuis/Chieco Bianchi 2006, 485 ff.

¹⁴³² Tecco Hvala/Dular/Kocuvan 2004, T. 133: 7.

¹⁴³³ Ibid., 71, T. 105: 26.

¹⁴³⁴ Ibid., 28, T. 7: 1, 2, 148: 1,2.

¹⁴³⁵ Ibid., 32.

¹⁴³⁶ Ibid., 67 f, Abb. 33.

italski polotok z razcvetom zlatarstva v Etruriji na eni strani in na drugi stepske kulture vzhodne Evrope.¹⁴³⁸

Zlatemu okrasju sta posebno pozornost namenili tudi Teržanova in Hellmuthova v razpravah o stiških gomilah in podrobneje predstavili tipologijo okraskov.¹⁴³⁹ Trikraki okrasek v obliki puščice ali drevesa je za zdaj poznan le iz dolenskih središč; primerka iz Stične in Velikega Vinjega vrha (Šmarjete) sta zlata, medtem ko je magdalenskogorski okrasek bronast, vsi trije pa pripadajo diademom iz časa stopnje Stična 2. Hellmuthova je predložila rekonstrukcijo oblačila pokojnice iz groba 48/27 v Stični, ki se zdi precej verjetna.¹⁴⁴⁰ Kot je zapisala, se je pri rekonstrukciji oprla predvsem na originalne skice tega groba in na ohranjene ostanke sprijetega okrasja. Ob tem si je pomagala še z raznorodnimi analogijami, med drugim tudi z upodobitvami žensk na izdelkih situlske umetnosti. Žene so na teh prizorih vedno pokrite z naglavnim ogrinjalom, ki je segalo čez ramena do pasu ali do meč in je okrašeno bodisi s črtkastim ali s karirastim vzorcem bodisi z gostim pikčastim okrasom in obrobo.¹⁴⁴¹ Tako nekako si lahko predstavljamo tudi svečana ženska oblačila z Magdalenske gore, ki so tem situlskim upodobitvam sočasna.

Sceptri in diademi nastopajo v ženskih in dekliških opravah, ki so vsebovale še razne druge predmete simbolnega značaja, kot so fibula s trovprego, obroček v obliki sonca, obeski, ki upodablajo ovnove glavice, posoda v obliki račk ipd. V račkah in simbolu sonca se zrcalita žarnogrobiščna ikonografija in starodavno čaščenje sonca.¹⁴⁴² S kultom sonca bi bilo prav tako možno povezati fibulo s trovprego, ki morebiti ponazarja Helijev voz,¹⁴⁴³ pa tudi jantar, v katerem je po starem ljudskem verovanju zbrana sončna energija.¹⁴⁴⁴ Vse to kaže na posebno vlogo teh izbrank, povezano s kultno sfero. Če se ozremo še na mesto pokopa teh izbrank, lahko ugotovimo, da so bile na Magdalenski gori pokopane v gomilah, v katerih so bili zabeleženi tudi grobovi pomembnih mož (Preloge, gomili 2 in 13), vendar se zdi, da to ni pravilo. V gomilah IV na Prelogah in V na Laščiku so bili odkriti prestižni moški grobovi s čeladami in konji, toda noben zares bogat

¹⁴³⁸ Guštin/Preložnik 2005, 145 ss, sl. 28.

¹⁴³⁹ Teržan/Hellmuth 2008.

¹⁴⁴⁰ Hellmuth 2008.

¹⁴⁴¹ Stare F. 1955a, pril. 1; Lucke/Frey 1962, T. 21, 64, 68, 73, Beil. 1 itd.; Bonfante 1981, Fig. 5–8,10, 11, 13, 16, 22, 25, 26, 46, 56, 59–63, 100, 104, 105; Turk 2005, sl. 2, 32–35, 37, 41, 42, 52, 53, 59, 75, s citirano literaturo. Podobna oblačila so znana tudi z daunijskih stel: D'Ercole 2000b, 329 ss, Fig. 1–3; Negroni Catacchio 2007, 535 ss.

¹⁴⁴² Kossack 1954a; id. 1996; id. 1999; Teržan 2003.

¹⁴⁴³ Glej tu poglavje 4.7.9 o figuralnih fibulah (*Kriegswagenfibel*).

¹⁴⁴⁴ Glej tu poglavje 4.8.2 o jantaru.

mentioned in Graves V/32 at Laščik and X/72 at Preloge. In the latter, gold leaves were reportedly found together with large amber beads at the knees of the deceased female, which also wore a boat and a serpentine fibula.¹⁴³⁷

Gold ornaments, as shown by Guštin and Preložnik, appeared in Bela krajina and the lower reaches of the Krka already in the Podzemelj 2 phase and later spread among the high society practically across the whole Dolenjska. Guštin and Preložnik indicated two possible areas of influence for the habit of wearing gold ornaments – the Italian Peninsula with the flourishing goldsmiths' craft in Etruria, on the one hand, and the steppe cultures of eastern Europe, on the other.¹⁴³⁸

Gold ornaments were also given special attention by Teržan and Hellmuth in their discussions on the tumuli from Stična, who also provided a typology.¹⁴³⁹ The three-pointed ornaments in the shape of either an arrow or a tree are thus far only known from the sites in Dolenjska. The two examples from Stična and Veliki Vinji vrh (Šmarjeta) are made of gold and the one from Magdalenska gora of bronze; all of them formed part of diadems from the Stična 2 phase. Hellmuth proposed a credible reconstruction of the costume of the female buried in Grave 48/27 at Stična.¹⁴⁴⁰ Her reconstruction is based primarily on the original sketches of the grave and the remains of the preserved, though clumped ornaments, further aided by various analogies, also with the situla art depictions of women. In the latter, women always wear a veil that covers the shoulders and reaches either to the waist or to the calves; it is decorated with a chevron, chequered or polka-dotted designs, and with borders.¹⁴⁴¹ We can imagine that the formal wear of the women from Magdalenska gora, contemporary to the situla art depictions, had the same appearance.

Sceptres and diadems were unearthed in the graves of women and girls in the company of other objects of symbolic significance, such as a fibula with a three-horse chariot, sun-shaped ring, pendants that depict a ram's head, a duck-shaped vessel and others. Of those, ducks and the sun symbol reflect the Urnfield culture iconography and ancient worship of the sun.¹⁴⁴² Possibly also tied to the sun cult is the fibula with a three-horse chariot that

¹⁴³⁷ Hencken 1978, 38,79.

¹⁴³⁸ Guštin/Preložnik 2005, 145 ff, Fig. 28.

¹⁴³⁹ Teržan/Hellmuth 2008.

¹⁴⁴⁰ Hellmuth 2008.

¹⁴⁴¹ Stare F. 1955a, App. 1; Lucke/Frey 1962, T. 21, 64, 68, 73, Beil. 1 etc.; Bonfante 1981, Figs. 5–8,10, 11, 13, 16, 22, 25, 26, 46, 56, 59–63, 100, 104, 105; Turk 2005, Figs. 2, 32–35, 37, 41, 42, 52, 53, 59, 75, with references. Similar clothing is known from Daunian stelae: D'Ercole 2000b, 329 ff, Figs. 1–3; Negroni Catacchio 2007, 535 ff.

¹⁴⁴² Kossack 1954a; id. 1996; id. 1999; Teržan 2003.

ženski grob. Na drugi strani pa zasledimo izstopajoče ženske oprave v gomilah, v katerih ni bilo enakovrednih moških pokopov (Preloge, gomila X in Voselca, gomila 2). Razen tega pokojnice v grobovih 13/36, 13/97, 13/117, 13/152 s scepri in zlatim nakitom, glede na rekonstruirani tlorisni načrt gomile 13, niso ležale v bližini mož, ki sta bila približno v istem času pokopana z najvišjimi častmi (13/55 in 13/119),¹⁴⁴⁵ zatorej bi v njih težko videli žene poglavarjev oz. "kneginje" ali njihove spremljevalke v onostranstvo, prej bi v njih lahko prepoznali svečenice.

4.12 DRUGI PRIDATKI

Med preostale grobne pridatke z Magdalenske gore, ki jih tukaj posebej ne obravnavam, spadajo še razna orodja ali pripomočki ter posodje. Pridano orodje v grobovih naj bi pričalo o statusu rokodelca v halštatski družbi, o čemer je razpravljala Teržanova.¹⁴⁴⁶ Moškim so pogosto pridali **brusne kamne**,¹⁴⁴⁷ ki se pojavljajo že v sklopu žarnih pokopov starejšega halštatskega obdobja (Laščik, gr. 8/2; Preloge, gr. VI/3, 13/10), sledimo pa jim lahko skozi vso starejšo železno dobo tja do njenega izteka (Laščik, gr. V/29). Pokojnikom so dajali v grob tudi **železna šila**.¹⁴⁴⁸ Največ takih primerov je izpričanih v mlajšem halštatskem obdobju v gomili 13. Kakšno obrtno dejavnost naj bi simbolizirala, pa ni povsem jasno.¹⁴⁴⁹

V marsikaterem ženskem ali dekliškem grobu naletimo na **vijčke**,¹⁴⁵⁰ ki so povezani s predilstvom.¹⁴⁵¹ Na tekstilno dejavnost se navezujejo tudi **šivanke**,¹⁴⁵² ki jih zasledimo med najdbami iz gomil na Prelogah, in so bodisi iz bron (X/43), železa (2/69) ali kosti (13/163).¹⁴⁵³ Status predilk oz. tkalk in simbolni pomen tovrstnih predmetov pa sta bila izpostavljena že v raznih

¹⁴⁴⁵ Tecco Hvala/Dular/Kocuvan 2004, sl. 28, 48.

¹⁴⁴⁶ Teržan 1994.

¹⁴⁴⁷ Hencken 1978, Fig. 4e, 144i, 176b, 218a, 320d,e; Tecco Hvala/Dular/Kocuvan 2004, T. 22: 15, 25: 21, 31A: 1,2, 68: 7, 77: 29, 126: 23, 169: 9,10.

¹⁴⁴⁸ Hencken 1978, Fig. 24d, 83k, 263f, 293b, 299i, 331f; Tecco Hvala/Dular/Kocuvan 2004, T. 36: 23, 45: 19,20, 62D: 10,11, 64: 20, 79A: 7, 79B: 3, 84: 12, 93C: 6, 103A: 4, 113B: 8, 114B: 6, 114F: 4, 122A: 10, 136A: 5, 161: 28-31.

¹⁴⁴⁹ Šila naj bi imela večnamensko funkcijo, znana pa so v že v bronastodobnih kulturah, kjer prav tako nastopajo med grobnimi pridatki: Willroth 1997, 481ss.

¹⁴⁵⁰ Hencken 1978, Fig. 5g, 10b,c; 37b-e, 75c, 77b,c, 107, 152a,b, 159c, 180a, 189b, 214a, 224b, 226l-n, 239a, 247a, 262a-e, 300b, 303a, 330f; Tecco Hvala/Dular/Kocuvan 2004, 28A: 5-10, 37A: 18-21, 57A: 4, 65C: 1-3, 77: 30, 79A: 9, 99A: 7-12, 104B: 4,5, 114E: 6, 115B: 5, 118: 11, 121C: 6-10, 123: 17, 126: 31, 129: 48, 130A: 15, 133: 22, 134D: 5, 173: 10-18.

¹⁴⁵¹ Grömer 2005.

¹⁴⁵² Mautendorfer 2005.

¹⁴⁵³ Hencken 1978, Fig. 334g,i; Tecco Hvala/Dular/Kocuvan 2004, T. 58B: 7, 123: 9.

may represent Helios' chariot,¹⁴⁴³ as well as amber, which stores the energy of the sun, according to old popular beliefs.¹⁴⁴⁴ These objects point to a special role, tied to the cult sphere, that these females enjoyed within the community. At Magdalenska gora, these females were buried in tumuli that also held graves of important men (Preloge, Tumuli 2 and 13), though this does not appear to be the rule. Tumuli IV at Preloge and V at Laščik, for example, revealed burials of men of distinction, with helmets and horses, but no exceptionally rich female grave. On the other hand, exceptional female grave groups were found in tumuli that yielded no equally exceptional male burials (Preloge, Tumulus X and Voselca, Tumulus 2). Moreover, the reconstructed ground-plan of Tumulus 13 shows that women in Graves 13/36, 13/97, 13/117, 13/152, with sceptres and gold jewellery, were not buried close to the men laid to rest at roughly the same time with the highest honours (13/55 and 13/119),¹⁴⁴⁵ and could thus not be seen as chieftains' wives or princesses, not even as their companions into the afterlife. These females could much sooner be interpreted as priestesses.

4.12 OTHER GRAVE GOODS

Apart from the grave goods from Magdalenska gora discussed thus far, there are several other categories of finds not specially treated, namely various implements and vessels. The implements placed in the grave together with the deceased are presumed to indicate his or her status of a craftsman within the Hallstatt society, which was discussed already by Teržan.¹⁴⁴⁶ Men were often given **whetstones**,¹⁴⁴⁷ which first appeared already in urn burials from the Early Hallstatt period (Laščik, Gr. 8/2; Preloge, Gr. VI/3, 13/10) and can be traced throughout the Early Iron Age (Laščik, gr. V/29). Some of the deceased were also buried with **iron awls**.¹⁴⁴⁸ Most graves with iron awls date to the Late Hallstatt period and were found in Tumulus 13. The craft that they represented, however, is not quite evident.¹⁴⁴⁹

¹⁴⁴³ See Chapter 4.7.9 on figural fibulae (*Kriegerwagen-fibel*).

¹⁴⁴⁴ See Chapter 4.8.2 on amber.

¹⁴⁴⁵ Tecco Hvala/Dular/Kocuvan 2004, Abb. 28, 48.

¹⁴⁴⁶ Teržan 1994.

¹⁴⁴⁷ Hencken 1978, Figs. 4e, 144i, 176b, 218a, 320d,e; Tecco Hvala/Dular/Kocuvan 2004, T. 22: 15, 25: 21, 31A: 1,2, 68: 7, 77: 29, 126: 23, 169: 9,10.

¹⁴⁴⁸ Hencken 1978, Figs. 24d, 83k, 263f, 293b, 299i, 331f; Tecco Hvala/Dular/Kocuvan 2004, T. 36: 23, 45: 19,20, 62D: 10,11, 64: 20, 79A: 7, 79B: 3, 84: 12, 93C: 6, 103A: 4, 113B: 8, 114B: 6, 114F: 4, 122A: 10, 136A: 5, 161: 28-31.

¹⁴⁴⁹ Awls may have served as multi-purpose implements. They were known already to the Bronze Age cultures, which also placed them in graves together with the deceased: Willroth 1997, 481ff.

razpravah.¹⁴⁵⁴ Med pridatki magdalenskogorskih grobov nastopajo tudi predmeti, ki so se morebiti uporabljali kot **toaletni pribor**.¹⁴⁵⁵

Razen tega so imeli navado, da so preminulim za popotnico priložili posodje, ki so ga običajno postavili k nogam, v žganih grobovih pa ob žaro ali v njo. Keramični repertoar je obdelal Dular,¹⁴⁵⁶ pivske servise za banket v grobovih halštatskih veljakov je predstavila Teržan.¹⁴⁵⁷ Posebne pozornosti je bilo deležno kovinsko posodje,¹⁴⁵⁸ zlasti figuralno okrašene situle, ki s svojo pripovedjo predstavljajo neusahljiv vir navdiha za razne interpretacije.¹⁴⁵⁹

Many graves of women or girls revealed **spindle whorls**,¹⁴⁵⁰ which are connected to spinning.¹⁴⁵¹ Also tied to handling textiles are the finds of **needles**,¹⁴⁵² found in the tumuli at Preloge. They were made either of bronze (X/43), iron (2/69) or bone (13/163).¹⁴⁵³ The status of spinners or weavers as well as the symbolic significance of the objects tied to the activities has formed the subject of many discussions.¹⁴⁵⁴ Apart from those, the grave goods from Magdalenska gora also include items that may have been used as **toilet instruments**.¹⁴⁵⁵

The graves from Magdalenska gora reveal the habit of burying the deceased with vessels, which were usually placed at their feet in inhumation graves and either beside or inside the urn in cremations. The range of ceramic vessels was already treated by Dular,¹⁴⁵⁶ while the banquet drinking sets found in graves of Hallstatt dignitaries were presented by Teržan.¹⁴⁵⁷ Of all the vessels, special attention was paid to those made of bronze,¹⁴⁵⁸ particularly the situlae with figural decoration that represent an infinite source of inspiration for various interpretations.¹⁴⁵⁹

¹⁴⁵⁴ Eibner 1984, 39 ss; Teržan 1996b; ead. 2004b, 221 ss; D'Ercole 2000b, 329 ss; ead. 2002a, 15 ss; Primas 2007.

¹⁴⁵⁵ Hencken 1978, Fig. 162b; Tecco Hvala/Dular/Kocuvan 2004, T. 67A: 5, 148: 13.

¹⁴⁵⁶ Dular J. 1982.

¹⁴⁵⁷ Teržan 1980; Gleirscher 2008b.

¹⁴⁵⁸ Kovinske posode v žganih grobovih sem obravnavala v poglavju 3.2.1. Za bronaste kotličke s križnimi atašami glej: Egg 1996, 100 ss, Abb. 58 s citirano starejšo literaturo; za bronaste narebrene ciste: Stjernquist 1967; Kimmig 1983, 40 s, Abb. 34; Stjernquist 1988, 161 ss, Abb. 88.

¹⁴⁵⁹ Stare F. 1955c; *Umetnost alpskih Ilirov in Venetov* 1962; Lucke/Frey 1962, Frey 1969; Huth 2003; Turk 2005; Teržan 2007b z izčrpano literaturo.

¹⁴⁵⁰ Hencken 1978, Figs. 5g, 10b,c; 37b-e, 75c, 77b,c, 107, 152a,b, 159c, 180a, 189b, 214a, 224b, 226l-n, 239a, 247a, 262a-e, 300b, 303a, 330f; Tecco Hvala/Dular/Kocuvan 2004, 28A: 5-10, 37A: 18-21, 57A: 4, 65C: 1-3, 77: 30, 79A: 9, 99A: 7-12, 104B: 4,5, 114E: 6, 115B: 5, 118: 11, 121C: 6-10, 123: 17, 126: 31, 129: 48, 130A: 15, 133: 22, 134D: 5, 173: 10-18.

¹⁴⁵¹ Grömer 2005.

¹⁴⁵² Mautendorfer 2005.

¹⁴⁵³ Hencken 1978, Fig. 334g,i; Tecco Hvala/Dular/Kocuvan 2004, T. 58B: 7, 123: 9.

¹⁴⁵⁴ Eibner 1984, 39 ff; Teržan 1996b; ead. 2004b, 221 ff; D'Ercole 2000b, 329 ff; ead. 2002a, 15 ff; Primas 2007.

¹⁴⁵⁵ Hencken 1978, Figs. 162b; Tecco Hvala/Dular/Kocuvan 2004, T. 67A: 5, 148: 13.

¹⁴⁵⁶ Dular J. 1982.

¹⁴⁵⁷ Teržan 1980; Gleirscher 2008b.

¹⁴⁵⁸ For bronze vessels from cremation graves see Chapter 3.2.1; for bronze cauldrons with cruciform handles see Egg 1996, 100 ff, Abb. 58 with references; for bronze ribbed cists see Stjernquist 1967; Kimmig 1983, 40 f, Abb. 34; Stjernquist 1988, 161 ff, Abb. 88.

¹⁴⁵⁹ Stare F. 1955c; *Umetnost alpskih Ilirov in Venetov* 1962; Lucke/Frey 1962; Frey 1969; Huth 2003; Turk 2005; Teržan 2007b with references.

5 NASTANEK IN RAZVOJ MAGDALENSKOGORSKE SKUPNOSTI

5 BEGINNING AND DEVELOPMENT OF THE MAGDALENSKA GORA COMMUNITY

Vzpetina s podolgovatim ploskim hrbtom in izstopajočim vrhom, od koder se širi razgled na rodovitno kotlino na jugozahodu, na alpske vrhove na severu ter na slemena rudonosnega Posavskega hribovja na vzhodu, je ponujala ugodne naravne pogoje za naselitev.¹⁴⁶⁰

Sledi človekove dejavnosti v pozni bronasti dobi razkrivata bodalo tipa Peschiera in tulasto kladivo iz brona, ki sta bila najdena v okolici Magdalenske gore.¹⁴⁶¹ Zametke skupnosti, ki se je naselila na tej vzpetini, pa bi lahko iskali v času stopnje Ljubljana II, o čemer pričajo igle z drobno bikonično, vazasto ali zankasto uvito glavico (*sl. 74: 2, 3, 6, 8, 9*), bronasta tordirana ovratnica (*sl. 101: 4*) in trakasta zapestnica iz bronaste pločevine.¹⁴⁶² Ti predmeti morebiti izvirajo iz planega žarnega grobišča, kajti v zabeležkah izkopavalcev najdemo namige o žarnih grobovih, ki naj ne bi bili pod gomilami.¹⁴⁶³

Nadaljnji razvoj te skupnosti pa lahko na podlagi analiz iz predhodnih poglavij razdelimo v pet faz, ki sovpadajo s kronološko shemo dolenske halštatske skupine.

FAZA I

V formativni fazi je bil grobni ritual še v veliki meri navezan na žarnogrobiščno tradicijo ljubljanske skupine (*sl. 129*). Žgane grobove so odkrili na severnem koncu nekropole (na Laščiku), pa tudi v gomilah bližje naselju (na Prelogah) in ob njegovem jugovzhodnem vznožju (na Voselci).

Na skici, ki je nastala leta 1892 ob kopanju na Laščiku, so označene štiri gomile (*sl. 128: IX–XII*) ter nekaj

Magdalenska gora is an elongated hill with a long flat summit and a protruding peak. It commands a view over the fertile basin to the south-west, Alpine peaks to the north and the Posavje Hills, rich in ore deposits, to the east. As such, it provided favourable natural conditions for settlement.¹⁴⁶⁰

The earliest traces of human activity in the Magdalenska gora area date to the Late Bronze Age, as evidenced by the Peschiera type dagger and a socketed hammer made of bronze.¹⁴⁶¹ The beginning of settlement proper, on the hill itself, however, can be traced to the Ljubljana II phase, as shown by biconical-, vase- or roll-headed pins (*fig. 74: 2, 3, 6, 8, 9*), a bronze twisted torque (*fig. 101: 4*) and a band bracelet made of sheet bronze.¹⁴⁶² These objects may originate from graves of a flat urn cemetery, the existence of which is inferred from excavators' notes on urn graves not covered by tumuli.¹⁴⁶³

The analyses performed in the previous chapters allow us to divide the development of the Magdalenska gora community into five phases.

PHASE I

In the formative phase, the funerary ritual was still largely tied to the Urnfield culture tradition of the Ljubljana group (*fig. 129*). Cremation graves from this time came to light along the northern edge of the cemetery (at Laščik), in tumuli closer to the settlement (at Preloge) and at the south-eastern foot of the hill (at Voselca).

The sketch made in 1892 during excavation at Laščik shows four tumuli (*fig. 128: IX–XII*), but also

¹⁴⁶⁰ Tecco Hvala/Dular/Kocuvan 2004, 9 ss; Dular/Tecco Hvala 2007, 162 ss, 204 ss.

¹⁴⁶¹ Hencken 1978, Fig. 296; Tecco Hvala/Dular/Kocuvan 2004, T. 165: 1. Obravnavam ju v poglavjih 4.1.1 o seki-rah in 4.1.3 o bodalih.

¹⁴⁶² Hencken 1978, Fig. 49b, 78b, 364r-s; Tecco Hvala/Dular/Kocuvan 2004, T. 148: 7,12, 149: 12; glej poglavja 4.6 o iglah ter 4.8.1 o ovratnicah in 4.9 o zapestnicah.

¹⁴⁶³ Glej poglavje 3.2.1 o žganih pokopih.

¹⁴⁶⁰ Tecco Hvala/Dular/Kocuvan 2004, 115 ff; Dular/Tecco Hvala 2007, 162 ff, 204 ff.

¹⁴⁶¹ Hencken 1978, Fig. 296; Tecco Hvala/Dular/Kocuvan 2004, T. 165: 1. See Chapter 4.1.1 on axes and 4.1.3 on daggers.

¹⁴⁶² Hencken 1978, Figs. 49b, 78b, 364r-s; Tecco Hvala/Dular/Kocuvan 2004, T. 148: 7,12, 149: 12; see Chapter 4.6 on pins, 4.8.1 on torques and 4.9 on bracelets.

¹⁴⁶³ See Chapter 3.2.1 on cremation burials.

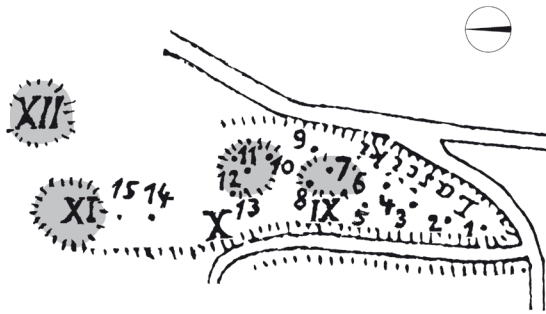

Sl. 128: Izsek iz Rutarjevega načrta severnega grobišča na Laščiku iz leta 1893; z rimskimi številkami so označene gomile, z arabskimi številkami pa grobovi.

Fig. 128: Section of the ground-plan of the northern cemetery at Laščik that Rutar made in 1893; tumuli are marked with Roman and graves with Arabic numerals.

grobov v vrsti izven njih (sl. 128: 1–5, 14, 15).¹⁴⁶⁴ Čeprav najdbe iz teh grobov niso ohranjene po grobnih celotah, pa je na podlagi opisov moč domnevati, da je šlo za žgane pokope iz najstarejše stopnje železne dobe, tj. stopnje Podzemelj. Bolj ali manj sočasno so verjetno nastale tudi prve gomile, kot sta gomili 11 in 12 s po enim žganim pokopom na severnem robu grobišča ter južneje ležeča gomila 8 (sl. 1), ki je vsebovala štiri grobove. Od teh so bili trije žarni, medtem ko za četrtega grobni ritual in pridatki niso zabeleženi. Od njega so ostale le tri lepe kamnite plošče, kar govori za to, da je bil bodisi izropan ali pa je predstavljal prazen centralni grob v smislu kenotafa.¹⁴⁶⁵

Podobna situacija kot na Laščiku se nakazuje tudi na Prelogah. Žarni grobovi, ki so bili v gomili VI razporejeni v vrsti (sl. 13), so sprva nemara pripadali planemu grobišču. V tej gomili so bile odkrite nekakšne grobne parcele, zamejene s kamni (omenjajo se namreč v krogu postavljeni kamni).¹⁴⁶⁶ V njihovi neposredni bližini pa so našli na tri žgane pokope v kamnitih skrinjah, ki so stale v različnih globinah v nasutju gomile (sl. 17: B in sl. 28).¹⁴⁶⁷ Možno bi bilo, da je gomila, ki se je z nadaljnjim pokopavanjem postopno večala, prekrila starejše plane grobove.

Na podoben način bi si lahko razlagali nastanek gomile 13 na Prelogah, v kateri so, sodeč po rekonstruiranem tlorisu, najstarejši žgani pokopi prav tako razporejeni v vrsti na njenem jugovzhodnem robu (sl. 16).¹⁴⁶⁸ Z njimi bi po lončenini lahko primerjali še žarni pokop 13/52 in skeletni grob 13/51 v severozahodnem

several graves positioned in a row outside the tumuli (fig. 128: 1–5, 14, 15).¹⁴⁶⁴ The grave groups are not preserved. Based on their descriptions, however, we may suppose that the graves were cremations from the earliest phase of the Iron Age, namely the Podzemelj phase. At roughly the same time, the first tumuli appeared, such as Tumuli 11 and 12 on the northern edge of the cemetery, containing a single cremation, and Tumulus 8, situated more to the south (fig. 1). The latter tumulus contained four graves, three of which were urn graves, while the rite and goods of the fourth are not documented. All that remained of it were three nice stone slabs, which indicates that either the grave had been robbed or it represented a cenotaph, occupying a central position.¹⁴⁶⁵

A similar situation to that at Laščik can be supposed at Preloge. The urn graves set in a row in Tumulus VI (fig. 13) might initially have formed part of a flat cemetery. The documentation for this tumulus also reveals a sort of grave plots, delimited by stones (stones positioned in a circle are mentioned).¹⁴⁶⁶ In their immediate vicinity, three cremation burials in stone cists were found, which lay at different depths within the earthen mound (fig. 17: B and fig. 28).¹⁴⁶⁷ The above leads to the supposition that the tumulus came to cover the earlier flat graves, as it gradually grew with continuous burying.

A similar explanation is plausible for Tumulus 13 at Preloge. The reconstructed ground-plan of the tumulus shows that the earliest cremation graves were positioned in a row, along the south-eastern edge (fig. 16).¹⁴⁶⁸ Comparable to these in pottery are urn Grave 13/52 and inhumation Grave 13/51 in the north-western part of the tumulus.¹⁴⁶⁹ The latter contained a small clay amphora such as were found in the urn cemeteries of the Ljubljana type.¹⁴⁷⁰ The second inhumation (13/134), supposed from the same phase (fig. 77), was found in the vicinity of the above-mentioned row of cremations in the south-eastern part of the tumulus.¹⁴⁷¹ Apart from flat graves, it is also possible that two or more tumuli stood here initially and later joined into one as burying continued; this would be indicated by an irregular shape of the tumulus that is drawn out in a NW-SE direction.

A similar drawn-out shape can be observed for Tumulus 6 at Voselca, which also revealed an urn grave (6/3) from the same phase, situated on the south-eastern edge.¹⁴⁷² Further urn graves were stumbled upon when

¹⁴⁶⁴ Tecco Hvala/Dular/Kocuvan 2004, 121 ff, Abb. 18.

¹⁴⁶⁵ Gr. 8/1, 8/2, 8/3, 8/4.

¹⁴⁶⁶ I.e. Graves VI/20, VI/24, VI/27, VI/36 and six unnumbered graves covered by stone slabs and without grave goods: Hencken 1978, 43 ff.

¹⁴⁶⁷ Gr. VI/3, VI/9, VI/10.

¹⁴⁶⁸ Gr. 13/147, 13/148, 13/157, 13/171, 13/173: Tecco Hvala/Dular/Kocuvan 2004, 76 f, 80, Abb. 40, 46.

¹⁴⁶⁹ *Ibid.*, 60 f.

¹⁴⁷⁰ Dular J. 1982, 35 f.

¹⁴⁷¹ Tecco Hvala/Dular/Kocuvan 2004, 73 f.

¹⁴⁷² *Ibid.*, 89.

¹⁴⁶⁴ Tecco Hvala/Dular/Kocuvan 2004, 21 ss, sl. 18.

¹⁴⁶⁵ Gr. 8/1, 8/2, 8/3, 8/4.

¹⁴⁶⁶ Gre za grobove VI/20, VI/24, VI/27, VI/36 in še šest neoštevilčenih žarnih grobov, pokritih s kamnito ploščo, ki niso imeli drugih pridatkov: Hencken 1978, 43 ss.

¹⁴⁶⁷ Gr. VI/3, VI/9, VI/10.

¹⁴⁶⁸ Gr. 13/147, 13/148, 13/157, 13/171, 13/173: Tecco Hvala/Dular/Kocuvan 2004, 76 s, 80, sl. 40, 46.

delu gomile;¹⁴⁶⁹ slednjemu je pripadala glinasta amforica, kakršne zasledimo v žarnih nekropolah ljubljanskega tipa.¹⁴⁷⁰ Drugi skeletni grob (13/134), ki ga lahko datiramo v to fazo (*sl.* 77), pa je ležal v bližini vrstnih žganih pokopov na jugovzhodnem delu gomile.¹⁴⁷¹ Morda sta bili na tem prostoru sprva postavljeni dve ali celo več gomil, ki so se z nadaljnjim pokopavanjem in nasipavanji spojile v eno, za kar bi govorila nepravilna razpotegnjena oblika v smeri SZ–JV.

Razpotegnjeno obliko ima tudi gomila 6 na Voselci, ki ji je pripadal žarni grob 6/3 iz te faze, ležal pa je na jugovzhodnem delu gomile.¹⁴⁷² Na pokope v žarah so prav tako naleteli pri kopanju višje ležečih gomil 2 in 5 na Voselci, vendar njihova natančnejša lega v gomili ni zabeležena.¹⁴⁷³

V prvi fazi imamo torej opraviti z žganimi pokopi v vrstah ali znotraj družinskih parcel pa tudi v kamnite skrinje, prekrite z gomilo, prav tako se pojavijo prvi skeletni grobovi. V keramičnem repertoarju so poleg žarnogrobišnih oblik opazne nekatere novosti, denimo posode na nogi z žebličastim in grafitnim okrasom v obliki meandra (*sl.* 21: *g, n*).¹⁴⁷⁴ Med redkimi kovinskimi pridatki prevladuje nakit, sestavljen iz bronastih ali železnih zapestnic (*sl.* 108, 109: 8), ki se v stopnji Ljubljana IIb in IIIa (= Podzemelj) pojavljajo v planih žarnih grobiščih od vzhodnih obronkov Pohorja do Posočja, v Gorjancih in Beli krajini pa tudi v skeletnih grobovih v gomilah.¹⁴⁷⁵ Ženske so takrat nosile dvozankaste vozlaste fibule tipa 5a po Gabrovcu (*sl.* 78: 7), ki so bile razširjene na istem območju, kot ga je poprej zavzemala t. i. ljubljanska žarnogrobišna skupina, medtem ko ima nakit pokojnice v skeletnem grobu 13/134 (*sl.* 77) najboljše paralele na Križni gori v stopnji Notranjska IIb (= Ljubljana IIb).¹⁴⁷⁶ Tipično moški atributi so redki;¹⁴⁷⁷ večglava igla s trombastim zaključkom (*sl.* 74: 1) iz kamnite skrinje VI/3 predstavlja zvest posnetek svetolucijskih primerkov iz stopenj Ib/Ic1 (= Ljubljana IIb/IIIa).¹⁴⁷⁸ Oprema najvidnejšega predstavnika te generacije (železna sekira z enostranskimi plavutmi, dereze), ki je bil pokopan v kamnito skrinjo v gomili 12 na Laščiku, pa spominja na vzhodnoalpsko nošo, npr. koroške halštatske skupnosti; morda mu je pripadala še stožčasta čelada picenske provenience (*54: levo zgoraj*).¹⁴⁷⁹

¹⁴⁶⁹ Ibid., 60 s.

¹⁴⁷⁰ Dular J. 1982, 35 s.

¹⁴⁷¹ Tecco Hvala/Dular/Kocuvan 2004, 73 s.

¹⁴⁷² Ibid., 89.

¹⁴⁷³ *Gr.* 2/1, 2/2, 2/3, 2/5, 2/15: Ibid., 83, 86.

¹⁴⁷⁴ Glej poglavje 3.2.1 o žarnih grobovih.

¹⁴⁷⁵ Glej poglavje 4.9 o železnih in bronastih zapestnicah.

¹⁴⁷⁶ Glej poglavje 4.7.1 o enozankastih in 4.7.2 o dvozankastih fibulah.

¹⁴⁷⁷ *Laščik, gr.* 8/2, 12/1; *Preloge, gr.* VI/3, 13/52; *Voselca, gr.* 2/24.

¹⁴⁷⁸ Glej poglavje 4.6 o iglah.

¹⁴⁷⁹ Glej poglavja 4.1 o orožju in 4.2 o čeladah ter 4.3.3 o derezah.

digging Tumuli 2 and 5 at Voselca, though their exact location within the tumulus was not documented.¹⁴⁷³

Thus the burial rite in the first phase is that of cremation, with burials positioned either in rows or within family plots, but also in stone cists, covered over by an earthen mound. Inhumations also made their first appearance. The array of ceramic vessels shows several novelties, such as footed vessels decorated with bronze studs or graphite meanders (*fig.* 21: *g, n*).¹⁴⁷⁴ Metal goods are rare and predominantly represented by jewellery items such as bronze or iron bracelets (*fig.* 108, 109: 8). In the Ljubljana IIb and IIIa (= Podzemelj) phases, these jewellery items appear in flat urn cemeteries from the eastern fringes of the Pohorje Hills to the Soča Valley, while in the Gorjanci Hills and in Bela krajina they were also documented in inhumation graves within tumuli.¹⁴⁷⁵ In Phase I, women wore two-looped fibulae with a knobbed bow of Type 5a after Gabrovce (*fig.* 78: 7), which were spread across the same area as previously occupied by the so-called Ljubljana Urnfield culture group. An exception is the jewellery of the female buried in inhumation Grave 13/134 (*fig.* 77), which shows closest analogies in Križna gora from the Notranjska IIb (=Ljubljana IIb) phase.¹⁴⁷⁶ Typically male attributes are rare.¹⁴⁷⁷ One of those is the multi-knobbed pin with a trumpet guard (*fig.* 74: 1) found in stone cist Grave VI/3, which represents a faithful copy of the Sveta Lucija examples from the Ib/Ic1 (= Ljubljana IIb/IIIa) phases.¹⁴⁷⁸ The outfit of the most prominent male representative of this generation (consisting of an iron winged axe and crampons), who was buried in a stone cist within Tumulus 12 at Laščik, is reminiscent of the East Alpine costume, for example that worn in the Carinthia / Koroška community. This individual may also have been buried with a conical helmet of Picene provenience (*54: top left*).¹⁴⁷⁹

To summarize, the Magdalenska gora community appears to have been formed from various groups of inhabitants, who buried their dead at separate locations (*fig.* 135). The majority of the inhabitants, however, most likely originated from an Urnfield culture milieu that had contacts with communities near and far already in this early time.

¹⁴⁷³ *Gr.* 2/1, 2/2, 2/3, 2/5, 2/15: Ibid., 83, 86.

¹⁴⁷⁴ See Chapter 3.2.1 on cremation burials.

¹⁴⁷⁵ See Chapter 4.9 on iron and bronze bracelets.

¹⁴⁷⁶ See Chapter 4.7.1 on single-looped and 4.7.2 on two-looped fibulae.

¹⁴⁷⁷ *Laščik, Gr.* 8/2, 12/1; *Preloge, Gr.* VI/3, 13/52; *Voselca, Gr.* 2/24.

¹⁴⁷⁸ See Chapter 4.6 on pins.

¹⁴⁷⁹ See Chapter 4.1 on weapons, 4.2 on helmets and 4.3.3 on crampons.

Stopnje Phases		Laščik Gom. / Tum.		Preloge Gom. / Tum.								Voselca		Faze Phases						
Dolenjska		1-13	V	II	2	IV	VI	VII	VIII	X	13	1-6	MG							
Podzemelj	1	1892/2 1892/5 1892/14 1893/2 8/2 8/4 12/1					20 24 26 27 35 36 10					141 147 148 157 171 173 134 51	2/1 2/2 2/3 2/5 2/15 2/24 6/3	I						
	2						3					52								
Stična	1	4/1 1892/6 1892/8 1892/10 1892/13 1882/1 1892/11 1893/1					2 15 16 31	7 32 46 40 49			48 101 105 158 163 42 125 161	2/6 6/1	II							
	2		32?	1a	h 48	3			9	70										
Kačaste fibule / Serpentine fibulae	1		34	27	2a	19 43 54	27 2 12 13 24 49	43	1	29	39	2	43 38 37 34/35 26 22	24 27 73 93 110	2/4 2/25	III a				
	2		28		3 6 9	27 39 64 57 73 81	33	37					24 55 61 72	69	41 88 92 136	2/12	III b			
Certoške fibule / Certosa fibulae	1		2		10 15	15 24 30 37 52 53 62 65 67 68 83 84	22 28 48	17		18 25 37	41	3 10 6	4 50 67 75	23 51	6 36 46 49 77 152	54 69 153	2/7 2/9 2/18	IV a		
	2		23 37 43	30 31 47	2	a c n P 4 11 14 17 55 56	b k? 13 38 46 47	23 26 30a	16 21 25 30	30		5 24 50	16	48 77	14 45	18 45 53 57 87 97 116 117 150	5 55 119	2/11 2/20 2/21	IV b	
Negovske čelade / Negova helmets	1		36 40	5 15 19/20 21 26a 29 39	2b 5 19a 21	5 8 25 40 80	j l-2 3 42 60 71 72 77	19 41	32 52	8 33a 34 42	12 29 32 39	9 10 22 48	13 19 36 44	4 15	36	12 18 21a 25 46 64 76 32/33	43 65 79 96	1 63 64 84 114 132	2/17 2/23	V a
	2		4	8 9 10 11 12 41	4	6 69	54 55 58								20		37 40 56 60	6/	V b	

Na osnovi teh indicev lahko sklepamo, da se je magdalenskogorska skupnost formirala iz različnih skupin naseljencev, ki so svoje umrle pokopavali na ločenih mestih (*sl. 135*). Večji del njenih prebivalcev je verjetno izviral iz žarnogrobiščne sredine, ki so imeli že v tej najzgodnejši fazi očitno stike z bližnjimi in daljnimi skupnostmi.

FAZA II

Dvojni grobni ritual se je v tej fazi nadaljeval, vendar se je pokopavanje brez sežiganja že bolj prijel (*sl. 129*); razen tega so začele nastajati nove gomile. Na severnem delu Laščika sta takrat bržkone nastali gomili 9 in 10 (*sl. 128: IX, X*), ki sta vsebovali tako žgane¹⁴⁸⁰ kot skeletne pokope.¹⁴⁸¹ Na južnem koncu tega grobišča je bila tedaj postavljena gomila 4 na Terišču, nove gomile so zrasle tudi na Prelogah (2, II, IV, VIII, X), seveda pa je rekonstrukcija takega poteka le nekakšen približek.

V grobnih pridatkih druge faze je čutiti vplive srednjeitalskega in severnojadranskega prostora. Med lončenino zasledimo reoksidacijsko žgane izdelke (situle in pitose), poslikane v rdeče-črni tehniki (*sl. 22: a-e*).¹⁴⁸² Pojavile so se prve bronaste posode (*sl. 23, 24: e*), ki so bile največkrat sežgane skupaj s preminulimi in položene v žaro, le-ta pa prekrita s tkanino, kar je bila svetolucijska, estenska ali vilanovska navada.¹⁴⁸³ Bronasto vedro tipa Kurd iz groba 4/1 na Laščiku ima najboljše primerjave v svetolucijskem krogu, medtem ko za bronasti krožnik iz groba 6/1 na Voselci najdemo paralele v Istri in srednji Italiji.¹⁴⁸⁴

V opravah tistega časa nastopa pester oblikovni repertoar, v katerem se zrcalita spletnje stikov med severnoitalskim, zahodnohalštatskim, vzhodnoalpskim in zahodnopanonskim svetom na eni strani in na drugi prežitki iz časa kulture žarnih grobišč. Slednje

¹⁴⁸⁰ *Gr. 1892/6, 1892/8, 1892/10, 1892/13.*

¹⁴⁸¹ *Gr. 1882/1, 1892/11, 1893/1.*

¹⁴⁸² *Laščik, gr. 1892/6, 1892/10, 1892/13, Preloge, gr. 13/105, 13/125, 13/163, Voselca, gr. 2/6, 6/1; glej poglavje 3.2.1 o tujih keramičnih formah.*

¹⁴⁸³ *Preloge, gr. VII/7, 13/95, 13/101.*

¹⁴⁸⁴ Glej poglavje 3.2.1 o bronastem posodju.

Sl. 129: Shematičen prikaz pokopov po posameznih gomilah in razvojnih fazah magdalenskogorske skupnosti.

Poudarjeno = žgani pokopi; *ležeče* = grobovi z orožjem; navadno = grobovi brez orožja.

Fig. 129: Schematic representation of burials according to tumuli and to phases of development of the Magdalenska gora community.

Bold = cremation burials; *italic* = graves with weapons; normal = graves without weapons.

PHASE II

The double burial rite continued in this phase, though inhumation was gradually gaining ground (*fig. 129*). New tumuli appeared. In the northern part of Laščik, Tumuli 9 and 10 rose (*fig. 128: IX, X*). They contained both cremations¹⁴⁸⁰ and inhumations.¹⁴⁸¹ Tumulus 4 rose in the southern part of the cemetery at Laščik and new tumuli (2, II, IV, VIII, X) also grew at Preloge. Having said that, such a sequence of events is only an approximation.

The grave goods of Phase II reveal influences from central Italy and the northern Adriatic. Pottery includes reoxidation-fired vessels (situlae and pithoi) with red and black painted decoration (*fig. 22: a-e*).¹⁴⁸² The first bronze vessels appear (*fig. 23, 24: e*), which were most often burnt together with the deceased and laid inside an urn, the latter covered by a piece of cloth, which is a Sveta Lucija, Este or Villanova custom.¹⁴⁸³ One such bronze vessel is the Kurd type bucket found in Grave 4/1 at Laščik, which has closest parallels in the Sveta Lucija circle. Another bronze vessel is a plate from Grave 6/1 from Voselca, which has best analogies in Istria and central Italy.¹⁴⁸⁴

The costume of this phase consists of a varied range of forms that reveal north Italian, west Hallstatt, east Alpine and west Pannonian influences intermingling with the relicts of the Urnfield culture period. The latter relicts could be seen in the bracelets with a rhombic cross-section and incised decoration (*fig. 109: 10*), earrings made of spiral wire or band rings with overlapping ends (*fig. 122: 1, 2, 5*), as well as the unique single-looped fibula with a leaf bow (*fig. 76: c*).¹⁴⁸⁵ The Urnfield culture tradition is further discernible in plain and twisted torques (*fig. 24: d*),¹⁴⁸⁶ while the knobbed torques (*fig. 101: 7-10*) are rather reminiscent of the Sveta Lucija costume.¹⁴⁸⁷ The newly appeared items are earrings made of flat wire with a longitudinal groove and overlapping ends (*fig. 122: 3*) as well as solid ribbed bracelets and anklets (*fig. 111: 4, 7*), which are geographically limited to Dolenjska.¹⁴⁸⁸ The longitudinally ribbed bracelet on *fig. 111: 16* is an import and reveals a connection with central and northern Italy.¹⁴⁸⁹ Female adornments also include numerous

¹⁴⁸⁰ *Gr. 1892/6, 1892/8, 1892/10, 1892/13.*

¹⁴⁸¹ *Gr. 1882/1, 1892/11, 1893/1.*

¹⁴⁸² *Laščik, Gr. 1892/6, 1892/10, 1892/13, Preloge, Gr. 13/105, 13/125, 13/163, Voselca, Gr. 2/6, 6/1; see Chapter 3.2.1 on foreign ceramic forms.*

¹⁴⁸³ *Preloge, Gr. VII/7, 13/95, 13/101.*

¹⁴⁸⁴ See Chapter 3.2.1 on bronze vessels.

¹⁴⁸⁵ *Preloge, Gr. VII/40, VII/46, VII/49, 2/48, 13/101.*

¹⁴⁸⁶ *Preloge, Gr. VI/15, VI/16, Voselca, Gr. 6/1.*

¹⁴⁸⁷ *Laščik, Gr. 1893/1, Preloge, Gr. VII/40, VII/49, X/37.*

¹⁴⁸⁸ *Preloge, Gr. 2/h, 2/48, 13/163, VI/2, VII/40, Voselca, Gr. 2/6.*

¹⁴⁸⁹ See Chapter 4.8.1 on torques, 4.9 on bracelets and 4.10 on earrings.

bi lahko videli v zaplestnicah z rombičnim presekom in vrezanim okrasom (sl. 109: 10), v uhanih iz spiralno zvite žice ali trakastih obročk s presegajočimi konci (sl. 122: 1, 2, 5) in v edinstveni enozankasti fibuli z listastim lokom (sl. 76: c).¹⁴⁸⁵ Žarnogrobiščna tradicija se odraža še v gladkih in tordiranih ovratnicah (sl. 24: d),¹⁴⁸⁶ medtem ko vozlaste ovratnice (sl. 101: 7–10) bolj spominjajo na svetolucijsko nošo.¹⁴⁸⁷ Novost predstavljajo uhani iz žice pravokotnega preseka z vzdolžno kaneluro in presegajočimi konci (sl. 122: 3) ter polne narebrenе zaplestnice in nanožnice (sl. 111: 4, 7), katerih pojav je geografsko omejen na dolenski prostor.¹⁴⁸⁸ Med importe pa bi lahko šteli vzdolžno narebreno zaplestnico (sl. 111: 16), ki govori o povezavah Dolenske s srednjo in severno Italijo.¹⁴⁸⁹ V ženskem nakitu je zdaj tudi precej jantarja in raznovrstnih fibul.¹⁴⁹⁰ Od dvozankastih fibul sta zastopana tipa 6a ali 6d po Gabrovcu (sl. 78: 5, 8),¹⁴⁹¹ ki sta značilna za vzhodnoalpski prostor in zahodno Panonijo, medtem ko primerki z votlim gladkim lokom predstavljajo lokalno različico (sl. 78: 2, 3).¹⁴⁹² Razširila se je tudi italska moda čolničastih fibul; iz Posočja ali severne Italije so morda izšle različice 3. skupine po Jerinovi (sl. 81: 2–4),¹⁴⁹³ ki so na Dolenskem dokaj redke. V lokalnih delavnicah so po italskih vzorih izdelovali velike čolničaste fibule s cikcak okrasom 1. skupine po Jerinovi, ki imajo železne igle (sl. 81: 1, 6, 7),¹⁴⁹⁴ kar je posebnost dolensko-belokranjskih primerkov. Sledile so jim čolničaste fibule t. i. šmarješkega tipa oz. različica 2b po Jerinovi (sl. 81: 9, 10),¹⁴⁹⁵ ki se je iz jugovzhodnoalpskega prostora razširila v zahodno Panonijo in še dlje proti severu. Italske korenine imajo še nekatere druge oblike fibul tega časa, kot so kačaste, trortaste in fibule z oblogo. Med starejše primerke kačastih fibul z Magdalenske gore sodijo kolenčasta z dvema zankama na loku (sl. 88: 8), ki je edini znani kos z Dolenske, ter tipi z valovitim lokom (sl. 88: 9), s pestiči in rozetami (sl. 88: 2–4) in njihov derivat, t. i. tip Este-Vače-Uffing (sl. 88: 1).¹⁴⁹⁶ V magdalenskogorskem repertoarju zasledimo še trortaste fibule svetolucijske in picenske provenience (sl. 84: 1–5),¹⁴⁹⁷ med najlepše

objects of amber as well as variously shaped fibulae.¹⁴⁹⁰ Of the two-looped, Types 6a or 6d after Gabrovec (fig. 78: 5, 8)¹⁴⁹¹ are characteristic of the eastern Alps and western Pannonia, whereby the examples with a plain and hollow bow represent a local, Dolenska variant (fig. 78: 2, 3).¹⁴⁹² Women also wore boat fibulae, which was a fashion that had come from Italy. The variants of Group 3 after Jerin, rather rare in Dolenska, originate either from the Soča Valley or from northern Italy (fig. 81: 2–4).¹⁴⁹³ Italian models were also used by the local workshops for the large boat fibulae with zigzag decoration and an iron pin of Group 1 after Jerin (fig. 81: 1, 6, 7),¹⁴⁹⁴ whereby the iron pin is characteristic of the Dolenska and Bela krajina examples. These were followed by the boat fibulae of so-called Type Šmarjeta or Variant 2b after Jerin (fig. 81: 9, 10),¹⁴⁹⁵ which spread from the eastern Alps into western Pannonia and further north. Serpentine and three-knobbed fibulae as well as those with an overlay have Italian roots. The earliest serpentine fibulae from Magdalenska gora is that with two loops on the bow (fig. 88: 8), which is the only example of its kind in Dolenska, but also types with a wavy bow (fig. 88: 9), with antennae and rosettes (fig. 88: 2–4) as well as their derivative, so-called Type Este-Vače-Uffing (fig. 88: 1).¹⁴⁹⁶ The fibulae from Magdalenska gora further include three-knobbed fibulae of either Sveta Lucija or Picene provenance (fig. 84: 1–5),¹⁴⁹⁷ while the most beautiful examples are those with an overlay that reveal the influence of the Orientalising style (fig. 86, 87).¹⁴⁹⁸

New trends can also be perceived in the male outfit. One such novelty is the composite helmet (fig. 56: 2, 3). The fragment of such a helmet from Grave 4/1 at Laščik depicts hoplites and palmettes, while the helmet from Grave IV/3 at Preloge is adorned by a winged sphinx. All these motifs form part of the Orientalising style on the Italian Peninsula, whence these helmets, or at least the idea behind them, originate.¹⁴⁹⁹ The same place of origin might be sought for the decorative technique using bronze appliqué on iron objects, such as can be observed on the axe from Grave VI/22 at Preloge (fig. 46: 13). Another novelty is that men now began fastening their clothes with serpentine fibulae rather than pins,¹⁵⁰⁰ thereby supposedly following the Italian fashion. There

¹⁴⁸⁵ Preloge, gr. VII/40, VII/46, VII/49, 2/48, 13/101.

¹⁴⁸⁶ Preloge, gr. VI/15, VI/16, Voseleca, gr. 6/1.

¹⁴⁸⁷ Laščik, gr. 1893/1, Preloge, gr. VII/40, VII/49, X/37.

¹⁴⁸⁸ Preloge, gr. 2/h, 2/48, 13/163, VI/2, VII/40, Voseleca, gr. 2/6.

¹⁴⁸⁹ Glej poglavja 4.8.1 o ovratnicah in 4.9 o zaplestnicah ter 4.10 o uhanih.

¹⁴⁹⁰ Glej poglavji 4.8.2 o jantarju in 4.7 o fibulah.

¹⁴⁹¹ Laščik, gr. 4/1, Preloge, gr. VI/15.

¹⁴⁹² Preloge, gr. VI/31.

¹⁴⁹³ Laščik, gr. 1892/13.

¹⁴⁹⁴ Laščik, gr. 1882/1, Preloge, gr. 13/101, Voseleca, gr. 2/6.

¹⁴⁹⁵ Preloge, gr. VIII/9, 13/42, Voseleca, gr. 2/6.

¹⁴⁹⁶ Preloge, gr. II/1a, VII/32, X/70, 13/95, 13/158, 13/161, Voseleca, gr. 2/6.

¹⁴⁹⁷ Preloge, gr. 2/48, VI/2, VII/40.

¹⁴⁹⁰ See Chapter 4.8.2 on amber and 4.7 on fibulae.

¹⁴⁹¹ Laščik, Gr. 4/1, Preloge, Gr. VI/15.

¹⁴⁹² Preloge, Gr. VI/31.

¹⁴⁹³ Laščik, Gr. 1892/13.

¹⁴⁹⁴ Laščik, Gr. 1882/1, Preloge, Gr. 13/101, Voseleca, Gr. 2/6.

¹⁴⁹⁵ Preloge, Gr. VIII/9, 13/42, Voseleca, Gr. 2/6.

¹⁴⁹⁶ Preloge, Gr. II/1a, VII/32, X/70, 13/95, 13/158, 13/161, Voseleca, Gr. 2/6.

¹⁴⁹⁷ Preloge, Gr. 2/48, VI/2, VII/40.

¹⁴⁹⁸ Preloge, Gr. VII/40, 2/h, 13/163.

¹⁴⁹⁹ See Chapter 4.2 on helmets.

¹⁵⁰⁰ "Schlangenfibeln mit Rädchen verziert" are mentioned, for example, in male Grave 13/95 at Preloge: Tecco Hvala/Dular/Kocuvan 2004, 67.

izdelke pa sodijo fibule z oblogo, v katerih se odraža vpliv orientalizirajočega sloga (sl. 86, 87).¹⁴⁹⁸

O novih trendih govorijo tudi moški pridatki, denimo sestavljene čelade (sl. 56: 2, 3). Fragment čelade iz groba 4/1 na Laščiku je okrašen z upodobitvijo hoplitov in palmetastim okrasom, čelado iz groba IV/3 s Prelog pa krasi krilata sfinga; ta motivika sodi v zakladnico t. i. orientalizirajoče umetnosti na italskem polotoku, od koder tovrstne čelade tudi izvirajo ali vsaj ideja zanje.¹⁴⁹⁹ Od tam je nemara prišla še tehnika krašenja železnih predmetov z bronastimi aplikami, ki je bila uporabljena pri sekiri iz groba VI/22 na Prelogah (sl. 46: 13). Moški so za spenjanje oblačil namesto igel pričeli uporabljati kačaste fibule,¹⁵⁰⁰ domnevno po vzgledih z italskega prostora, medtem ko povezave z zahodnohalštatskim svetom nakazuje konjska oprema, h kateri bi lahko pripisali bronasti zatič iz žganega groba 13/95 na Prelogah (sl. 61: 2).¹⁵⁰¹ Pravokotne pasne sponje z zakovicami ob krajših stranicah za pritrditev na pas in železne tulaste sekire¹⁵⁰² pa so plod domače ustvarjalnosti in so v poznejših fazah postale prepoznavni znak dolenskih bojevnikov (sl. 54).

V tej fazi je čutiti vzpon magdalenskogorske skupnosti in naraščanje prebivalstva, kar je moč sklepati po materialnem bogastvu na eni strani in na drugi po širjenju grobišč, kajti takrat je dozdevno nastalo največ gomil (sl. 129 in sl. 135). V grobnih pridatkih zasledimo najraznovrstnejše kombinacije. Nekatere pripadnice te skupnosti so nosile obročasti nakit v garniturah, sestavljenih iz več kosov, v njihovem številu se morebiti skriva simbolni pomen, vezan na položaj in starost pokojnice.¹⁵⁰³ Izbranke so se ponašale z jantarnim in zlatim okrasjem ter diademom in sceptorom (sl. 125: 4, 5).¹⁵⁰⁴ V okrasju je opazno veliko mešanje stilov: ob žarnogrobiščnih komponentah in lokalnih prvih so zaznavne nekatere novosti in oblike, ki izvirajo iz drugih kulturnih okolij. Mešanje prebivalstva je prav tako diagnosticiral Angel na osnovi analize človeških okostij, ko je v morfologiji lobanj z Magdalenske gore prepoznal tako alpske kot mediteranske poteze.¹⁵⁰⁵

Te spremembe si lahko razlagamo kot posledico intenzivnejšega vključevanja Magdalenske gore v orbito blagovne menjave, kar je prispevalo tudi k večji

¹⁴⁹⁸ Preloge, gr. VII/40, 2/h, 13/163.

¹⁴⁹⁹ Glej poglavje 4.2 o čeladah.

¹⁵⁰⁰ V moškem grobu 13/95 s Prelog se omenjata dve "Schlangenfibel mit Rädchen verziert": Tecco Hvala/Dular/Kocuvan 2004, 67.

¹⁵⁰¹ Glej poglavje 4.3 o konjski opremi.

¹⁵⁰² Preloge, gr. IV/3, IV/11; glej poglavji 4.1 o orožju in 4.4 o pasnih sponah.

¹⁵⁰³ Laščik, gr. 1882/1, 1892/11, Preloge, gr. 2/48, 13/163, VI/2, VII/7, VII/40, VII/46.

¹⁵⁰⁴ Laščik, gr. V/32; Voselca, gr. 2/6; glej poglavje 4.11 o diademu in sceptorih.

¹⁵⁰⁵ Glej poglavje 1.1.3 o analizi človeških kostnih ostankih.

were also connections with the west Hallstatt world, as evidenced by horse gear, a part of which can also be seen in the bronze toggle from cremation Grave 13/95 at Preloge (fig. 61: 2).¹⁵⁰¹ On the other hand, the rectangular belt clasps with rivets along the shorter sides as well as iron socketed axes¹⁵⁰² are products of local creativity and came to represent a distinguishing mark of the male outfit of Dolenjska in subsequent phases (fig. 54).

The Magdalenska gora community in Phase II gained in importance as well as in number of inhabitants. This is observable in the material wealth, but also in the spread of cemeteries with the highest number of tumuli supposedly created in this phase (fig. 129 and fig. 135). Grave goods appear in various combinations. Some female members of the community wore ring jewellery in sets, whereby the number of pieces within a set may symbolize the standing and age of the deceased.¹⁵⁰³ Select women boasted amber and gold ornaments, as well as diadems and sceptres (fig. 125: 4, 5).¹⁵⁰⁴ These ornaments reveal a mélange of styles; Urnfield culture and local elements exist side by side with novelties and forms originating from foreign cultural milieus. Besides objects, the analysis performed by Angel on the human skeletal remains also revealed a mixing of the population, since the skulls from Magdalenska gora revealed both Alpine and Mediterranean traits.¹⁵⁰⁵

These changes may be interpreted as the consequence of a more important role that Magdalenska gora played in the wider exchange of goods, which contributed to an increased social differentiation.¹⁵⁰⁶ The prestigious grave goods indicate that the local elite embraced mainly the Mediterranean ideals of aristocratic life and imitated the cultural patterns of the Orientalising period.

PHASE III

The period of economic prosperity in the seventh century appears to have been followed by a recession in the sixth century, which can be discerned from a decreased influx of prestigious objects from more distant places as well as poorer and less varied grave goods. Changes are also observable in the texture of the cemeteries (fig. 129 and fig. 135). On the northern

¹⁵⁰¹ See Chapter 4.3 on horse gear.

¹⁵⁰² Preloge, Gr. IV/3, IV/11; see Chapter 4.1 on weapons and 4.4 on belt clasps.

¹⁵⁰³ Laščik, Gr. 1882/1, 1892/11, Preloge, Gr. 2/48, 13/163, VI/2, VII/7, VII/40, VII/46.

¹⁵⁰⁴ Laščik, Gr. V/32; Voselca, Gr. 2/6; see Chapter 4.11 on diadem and sceptres.

¹⁵⁰⁵ See Chapter 1.1.3 on anthropological remains.

¹⁵⁰⁶ Gabrovec 1987, 97 ff; *id.* 1992b; Teržan 1995b; *ead.* 2007a; *ead.* 2008, 294 ff; Palavestra 1993, 281 ff; D'Ercole 2002a; *ead.* 2002b; and various articles in: Aigner-Foresti (ed.) 1992; Hänsel (ed.) 1995; Lang/Salač (eds.) 2002; Guštin/Ettel/Buora (eds.) 2007.

družbeni diferenciaciji.¹⁵⁰⁶ Videti je, da se je lokalna elita spogledovala predvsem z mediteranskimi ideali aristokratskega življenja in posnemala kulturne vzorce t. i. orientalizirajočega obdobja.

FAZA III

Ugodni gospodarski konjunkturi v 7. st. je nato v 6. st. pr. n. št. dozdevno sledila recesija, ki se je odrazila v šibkejšem dotoku prestižnih predmetov iz bolj oddaljenih krajev in upadu bogastva ter manjši pestrosti grobnih pridatkov. Spremembe so prav tako vidne v teksturi grobišč (*sl. 129 in sl. 135*): v severnem delu grobišča na Laščiku so tedaj prenehali pokopavati, dozdevno so opustili tudi pokopavanje v gomilo VI na Prelogah, saj v to fazo ne moremo prepričljivo postaviti nobenega groba iz te gomile, razen sestava VI/1 z vozlasto ovratnico in kačasto fibulo s sedlastim lokom. Prav tako so se zredčili pokopi v sosednji gomili VII,¹⁵⁰⁷ po drugi strani pa se je pomnožilo število pokopov v gomilah 2, IV in X na Prelogah.

V pogrebnem ritualu je prevladala inhumacija. V redkih žganih grobovih iz tega časa¹⁵⁰⁸ bi lahko prepoznali prišleke iz drugih okolij, kot npr. v grobovih 2/25 z Voselca z grobim estenskim loncem (*sl. 22: g*) ali pa 13/24 s svetolucijskim tipom uhana (*sl. 122: 11*). Mednje bi lahko uvrstili še grob 13/10 s periferno lego v gomili na Prelogah, ki je med drugim vseboval širokolistno sulično ost, podobno picenskimi, in apulska kraterja z dobro paralelo v istrskem Nezakciju (*sl. 29, 54: desno zgoraj*).¹⁵⁰⁹ Apulska kraterja sta poslednja iz serije tovrstnih najdb v dolensko-belokranjski regiji, ki markirajo čezjadransko povezavo s srednjo Italijo; dvogrebenasta čelada iz groba VII/39 na Prelogah (*sl. 58*) pa je prva v nizu čelad tega tipa, ki so jih pozneje izdelovali v lokalnih delavnicah.¹⁵¹⁰ Oprava tega vodilnega predstavnika hkrati napoveduje uniformnost v moški noši, h kateri so spadali tulasta sekira, dve sulici, nož, fibula in pravokotna pasna spona.¹⁵¹¹ Podobno je bil opremljen pripadnik sosednje gomile (2/57),¹⁵¹² z obema pa je bil pokopan tudi konj. Konj v grobu VII/39 je imel dvodelne železne brzde z gibljivimi obročki (*sl. 61: 1*), ki

part of the cemetery at Laščik, burial into Tumulus VI at Preloge ceased, since a single grave group can be set into this phase, namely VI/1 with a knobbed torque and a serpentine fibula with a saddle-shaped bow. Burial also decreased in adjacent Tumulus VII,¹⁵⁰⁷ while it increased in Tumuli 2, IV and X at Preloge.

The dominant funerary rite became that of inhumation. The rare cremations from this phase¹⁵⁰⁸ might represent foreigners, for example the individual buried in Grave 2/25 at Voselca, containing a coarse Este jar (*fig. 22: g*), Grave 13/24 with a Sveta Lucija type earring (*fig. 122: 11*) and possibly also Grave 13/10, which contained, among other goods, a broad-bladed spearhead similar to those from Picenum as well as two Apulian *kratere* with the closest parallel at Nesactium in Istria (*fig. 29, 54: top right*).¹⁵⁰⁹ The Apulian *kratere* are the last in the series of finds in Dolenska and Bela krajina that mark a transadriatic connection with central Italy. On the other hand, the double-crested helmet from Grave VII/39 at Preloge (*fig. 58*) is the first in the series of helmets of this type that were later produced in local workshops.¹⁵¹⁰ The grave goods of the leading representative in the latter grave also announce uniformity in the male outfit, which consisted of a socketed axe, two spears, a knife, a fibula and a rectangular belt clasp.¹⁵¹¹ A similar outfit can be observed in the member of the adjacent tumulus (Grave 2/57).¹⁵¹² Both were buried with a horse. The horse in Grave VII/39 also had a two-piece bridle-bit with movable side rings (*fig. 61: 1*), known from the northern fringes of the Alps to western Pannonia, on the one side, and the Po Plain, on the other. The horse in Grave 2/57 was adorned with phalerae of the so-called Thracio-Cimmerian type and three-knobbed strap buttons (*fig. 61: 7, 8*), which were spread from Bavaria to Etruria.¹⁵¹³ The two-knobbed fibula worn by the man buried in Grave 13/126 at Preloge (*fig. 85: 2*) represents an import from the Alps, since the fibula type is very rare in Dolenska. In comparison to the previous phase, the formal range of fibulae reduced considerably. Serpentine fibulae of simple forms were prevalent – with a saddle-shaped bow,¹⁵¹⁴ with wings¹⁵¹⁵

¹⁵⁰⁶ Gabrovec 1987, 97 s; id. 1992b; Teržan 1995b; ead. 2007a; ead. 2008, 294 ss; Palavestra 1993, 281 ss; D'Ercole 2002a; ead. 2002b; ter razni prispevki v: Aigner-Foresti (ur.) 1992; Hänsel (ur.) 1995; Lang/Salač (ur.) 2002; Guštin/Ettel/Buora (ur.) 2007.

¹⁵⁰⁷ Podoben primer srečamo na *Molniku*: Puš 1991, 38.

¹⁵⁰⁸ *Preloge, gr. IV/27, X/43, 13/10, 13/24; Voselca, gr. 2/4, 2/25.*

¹⁵⁰⁹ Glej poglavje 3.2.1 o žganih pokopih in tujih keramičnih formah ter 4.10 o uhanih; za primerjave pa Teržan 1995b, 88, Abb. 15; Mihovilič 1995, 294 s, T. 4: 5.

¹⁵¹⁰ Glej poglavje 4.2 o dvogrebenastih čeladah.

¹⁵¹¹ Hencken 1978, Fig. 258, 259, Weiss 1999, Abb. 63, Taf. 19.

¹⁵¹² Tecco Hvala/Dular/Kocuvan 2004, 44.

¹⁵⁰⁷ Similar situation was evidenced at *Molnik*: Puš 1991, 38.

¹⁵⁰⁸ *Preloge, Gr. IV/27, X/43, 13/10, 13/24; Voselca, Gr. 2/4, 2/25.*

¹⁵⁰⁹ See Chapter 3.2.1 on cremation burials and foreign ceramic forms, as well as 4.10 on earrings; cf. Teržan 1995b, 88, Abb. 15; Mihovilič 1995, 294 f, T. 4: 5.

¹⁵¹⁰ See Chapter 4.2 on double-crested helmets.

¹⁵¹¹ Hencken 1978, Figs. 258, 259, Weiss 1999, Abb. 63, Taf. 19.

¹⁵¹² Tecco Hvala/Dular/Kocuvan 2004, 44.

¹⁵¹³ See Chapter 4.3 on horse gear.

¹⁵¹⁴ *Laščik, Gr. V/27, V/35; Preloge, Gr. II/2a, IV/2, IV/12, IV/13, IV/24, IV/27, IV/43, IV/49, VII/39, X/22, X/26, X/34–35, X/38, X/43, X/55, 2/19, 2/54, 2/81, 13/73; Voselca, Gr. 2/4, 2/12.*

¹⁵¹⁵ *Preloge, Gr. II/3, X/55, X/61, X/69, X/72, 2/57, 13/88, 2/12.*

so bile razširjene od severnega obroba Alp in zahodne Panonije do Padske nižine. Konj iz groba 2/57 pa je bil ozaljšan z razdelilnimi gumbi t. i. trakokimerijskega tipa in jermenskimi troglavimi gumbki (sl. 61: 7, 8), ki se pojavljajo od Bavarske do Etrurije.¹⁵¹³ K importom z alpskega prostora lahko pripišemo dvortasto fibulo, ki jo je nosil možak, pokopan v grobu 13/126 na Prelogah (sl. 85: 2), saj je na Dolenjskem zelo redka. Oblikovni diapazon fibul se je glede na prejšnjo fazo precej skrčil; prevladale so kačaste fibule enostavnih oblik – s sedlastim lokom,¹⁵¹⁴ s krilci¹⁵¹⁵ ali s ploščico (sl. 88: 5, 6, 11–14),¹⁵¹⁶ ob njih zasledimo še trakaste fibule (sl. 91)¹⁵¹⁷ ter dolgonožno fibulo z mrežastim okrasom na loku (sl. 92: 1).¹⁵¹⁸ Vse te različice se pojavljajo na območju med rekama Adige in Savo,¹⁵¹⁹ kar govori o zoženi mreži stikov.

V ženski noši je v primerjavi s predhodno fazo zaznavna večja homogenost. V obročastem nakitu sta se uveljavila "narebreni stil" okraševanja in oblika s prese-gajočimi stanjšanimi konci (sl. 111: 3),¹⁵²⁰ ki sta značilni prvini dolenjskih izdelkov. Ženske in deklince so v tej fazi nosile v glavnem po eno ali dve zapestnici, včasih še par nanožnic, medtem ko so garniture obročastega okrasja domala povsem izginile. V paru so nosile tudi uhane s prese-gajočimi konci, izdelane iz žice pravokotnega preseka z vzdolžno kaneluro (sl. 122: 3).¹⁵²¹ Poleg teh se zdaj pojavijo še kompleti štirih ali šestih trakastih uhanov oz. lasnih obročkov iz tanke bronaste pločevine, ki se spenjajo s kvačico in imajo punciran, vrezan ali narebren okras (sl. 122: 6, 8–10).¹⁵²² V nekaterih ženskih opravah zasledimo lasne igle¹⁵²³ in vozlaste ali narebren ovratnice (sl. 101: 5, 7, 8),¹⁵²⁴ vendar so bile bolj priljubljene ogrlice iz debelih temnomodrih steklenih jagod in/ali jantarnih jagod.¹⁵²⁵ Jantar je v tej fazi dosegel svoj višek ne le na Dolenjskem (sl. 106), temveč tudi v skupnostih

or with a plate (fig. 88: 5, 6, 11–14),¹⁵¹⁶ while band bow fibulae (fig. 91)¹⁵¹⁷ and a long-footed fibula with reticular decoration on the bow were also used (fig. 92: 1).¹⁵¹⁸ All these variants were only present in the area between the rivers Adige and Sava,¹⁵¹⁹ which points to a reduced network of contacts.

The female costume became more homogeneous in comparison to the previous phase. Ring jewellery showed a taste for the "ribbed style" as well as rings with overlapping and tapering ends (fig. 111: 3),¹⁵²⁰ both typical elements of the Dolenjska jewellery. Women and girls mainly wore one or two bracelets, sometimes in combination with a pair of anklets, while the set of ring jewellery disappeared. They wore, in pairs, earrings with a longitudinal groove and overlapping ends, made of flat wire (fig. 122: 3).¹⁵²¹ Apart from those, there are also sets of four or six band ear- or hair-rings made of thin sheet bronze, with a hook-and-eye closure (fig. 122: 6, 8–10).¹⁵²² The costume sometimes included hair pins¹⁵²³ as well as knobbed or ribbed torques (fig. 101: 5, 7, 8),¹⁵²⁴ though the latter were less popular than necklaces of thick dark blue glass and/or amber beads.¹⁵²⁵ The use of amber reached its peak in this phase not only in Dolenjska (fig. 106), but across the north-western Balkans (at Donja Dolina as well as in the Iapodic and Glinac areas), which points to an interrelation of the amber phenomenon on a wider geographical scale.¹⁵²⁶ Already from the end of the previous phase onwards, the Dolenjska community had good partners among the inhabitants of Donja Dolina in the lower reaches of the Sava. This is evidenced by fibulae of Type Šmarjeta, with an overlay, serpentine with a saddle-shaped bow or with wings as well as band bow, Alpine two-knobbed and other fibulae found in the graves at Donja Dolina.¹⁵²⁷ On the other hand, Dolenjska formed its own costume in this phase, which is a symbolic expression of the cohesion and of the Dolenjska cultural identity.

¹⁵¹³ Glej poglavje 4.3 o konjski opremi.

¹⁵¹⁴ Laščik, gr. V/27, V/35; Preloge, gr. II/2a, IV/2, IV/12, IV/13, IV/24, IV/27, IV/43, IV/49, VIII/39, X/22, X/26, X/34–35, X/38, X/43, X/55, 2/19, 2/54, 2/81, 13/73; Voseleca, gr. 2/4, 2/12.

¹⁵¹⁵ Preloge, gr. II/3, X/55, X/61, X/69, X/72, 2/57, 13/88, 2/12.

¹⁵¹⁶ Preloge, gr. IV/33, IV/37, 13/41.

¹⁵¹⁷ Laščik, gr. V/28; Preloge, gr. 2/27, 2/39, 2/73, 13/92, 13/136.

¹⁵¹⁸ Laščik, gr. V/28.

¹⁵¹⁹ Glej poglavje 4.7 o fibulah.

¹⁵²⁰ Laščik, gr. V/34; Preloge, gr. II/3, IV/2, IV/9, IV/24, X/22, X/24, X/38, X/72, 2/19, 2/27, 2/64, 13/88; Voseleca, gr. 2/12.

¹⁵²¹ Preloge, gr. II/9, IV/2, IV/9, IV/13, X/61, 13/27, 13/73, 13/93, 13/110.

¹⁵²² Preloge, gr. IV/12, IV/49, X/26, X/43, 2/27, 2/39, 2/54, 13/88; Voseleca, gr. 2/12. Glej poglavje 4.10 o uhanih.

¹⁵²³ Preloge, gr. X/38, 2/39, 2/81; glej poglavje 4.6 o iglah.

¹⁵²⁴ Preloge, gr. 2/73, X/24, VI/1, X/37.

¹⁵²⁵ Laščik, gr. V/34, Preloge, gr. II/9, IV/9, IV/27, X/22, X/24, X/26, X/34–35, X/61, X/72, 2/19, 2/27, 2/54, 13/41, 13/88; Voseleca, gr. 2/12; glej poglavje 4.8 o ovraticah in ogrlicah.

¹⁵¹⁶ Preloge, Gr. IV/33, IV/37, 13/41.

¹⁵¹⁷ Laščik, Gr. V/28; Preloge, Gr. 2/27, 2/39, 2/73, 13/92, 13/136.

¹⁵¹⁸ Laščik, Gr. V/28.

¹⁵¹⁹ See Chapter 4.7 on fibulae.

¹⁵²⁰ Laščik, Gr. V/34; Preloge, Gr. II/3, IV/2, IV/9, IV/24, X/22, X/24, X/38, X/72, 2/19, 2/27, 2/64, 13/88; Voseleca, Gr. 2/12.

¹⁵²¹ Preloge, Gr. II/9, IV/2, IV/9, IV/13, X/61, 13/27, 13/73, 13/93, 13/110.

¹⁵²² Preloge, Gr. IV/12, IV/49, X/26, X/43, 2/27, 2/39, 2/54, 13/88; Voseleca, Gr. 2/12. See Chapter 4.10 on earrings.

¹⁵²³ Preloge, Gr. X/38, 2/39, 2/81; see Chapter 4.6 on pins.

¹⁵²⁴ Preloge, Gr. 2/73, X/24, VI/1, X/37.

¹⁵²⁵ Laščik, Gr. V/34, Preloge, Gr. II/9, IV/9, IV/27, X/22, X/24, X/26, X/34–35, X/61, X/72, 2/19, 2/27, 2/54, 13/41, 13/88; Voseleca, Gr. 2/12; see Chapter 4.8 on torques and necklaces.

¹⁵²⁶ See Chapter 4.8.2 on amber.

¹⁵²⁷ Truhelka 1904, T. 41: 8, 42: 16, 45: 19, 46: 15, 47: 10, 13, 15, 48: 10, 13, 15, 46: 30, 56: 9, 17–20, 22, 58: 6, 65: 8, 16, 75: 9, 76: 11.

severozahodnega Balkana (v Donji Dolini ter v japonskem in glasinaškem prostoru), kar kaže na medsebojno odvisnost tega pojava v širšem geografskem okviru.¹⁵²⁶ Že ob koncu predhodne faze je imela dolenska skupnost dobrega sogovornika predvsem v prebivalcih Donje Doline, ki leži ob spodnjem toku Save. V tamkajšnjih grobovih srečamo t. i. šmarješke čolničaste fibule, fibulo z oblogo, kačaste fibule s sedlastim lokom ali s krilci ter trakaste in alpske dvortaste fibule ipd.¹⁵²⁷ Na drugi strani pa smo v tem času priča izoblikovanju lokalne noše, ki na simbolni ravni izraža kohezijo in identiteto dolenske teritorialne skupnosti.

FAZA IV

Za prebivalce Magdalenske gore je naposled napočil čas največje blaginje in razcveta, ko se je povzpela med najpomembnejša središča jugovzhodnoalpskega sveta, za kar govori vrsta kazalnikov, ki so poglavitni znanilci novih časov (certoške fibule, izdelki situlske umetnosti idr.).¹⁵²⁸

V tej fazi se je znatno povečalo število pokopov, zlasti v gomilah 2 in 13 na Prelogah,¹⁵²⁹ hkrati pa je opazno naraslo število oboroženih pripadnikov (sl. 129). V oborožitvi so zastopane tulaste sekire (sl. 46: 4–6, 8, 10), sulice (sl. 48: 3, 6; 49: 2; 50: 2, 4) in noži s trnastim nastavkom za lesen držaj (sl. 53: 1), ki sestavljajo tipično opremo dolenskih bojevnikov. Nekateri so imeli še zbirko različnih puščic za lok, med katerimi so v največjem številu zastopane t. i. skitske trirobe puščične osti (sl. 51).¹⁵³⁰ Lokalna vojaška elita se je ponašala s čeladami dvogrebenastega tipa, ki so bile domnevno izdelane v dolenskem delavniškem krogu (sl. 56: 4, 7–9),¹⁵³¹ o čemer govori tudi čelada z narebreno kaloto, ki je brez primere (sl. 56: 10). V ta čas bi spadala še etruščanska čelada negovskega tipa, t. i. različica Volterra po Eggu (sl. 59), katere pripadnost zapuščini magdalenskogorske skupnosti temelji le na domnevi.¹⁵³² Med simbole oblasti in visokega družbenega ranga se uvrščajo še žezla (sl. 71: 6, 8),¹⁵³³

¹⁵²⁶ Glej poglavje 4.8.2 o jantarju.

¹⁵²⁷ Truhelka 1904, T. 41: 8, 42: 16, 45: 19, 46: 15, 47: 10, 13, 15, 48: 10, 13, 15, 46: 30, 56: 9, 17–20, 22, 58: 6, 65: 8, 16, 75: 9, 76: 11.

¹⁵²⁸ Izdelki situlske umetnosti z Magdalenske gore so predstavljeni v številnih študijah in razpravah; v sklopu grobnih celot pa so objavljeni v: Tecco Hvala/Dular/ Kocuvan 2004, T. 8: 8, 9: 3, 14: 3, 24: 3, 41: 1, 53: 1, 85: 17, 105: 1–6, pril. 2–6, 9–12A, 13. O čeladah in certoških fibulah glej poglavji 4.2 in 4.7.8.

¹⁵²⁹ Tecco Hvala/Dular/ Kocuvan 2004, sl. 50.

¹⁵³⁰ Preloge, gr. 2/13, 2/38, 13/5; glej poglavje 4.1.2 o puščicah.

¹⁵³¹ Preloge, gr. 2/g, 2/13, 2/38, 13/119.

¹⁵³² Glej poglavje 4.2 o čeladah.

¹⁵³³ Preloge, gr. 2/13, 13/55.

PHASE IV

In this phase, the Magdalenska gora community witnessed a period of greatest wealth and prosperity, when it became one of the most prominent centres of the south-eastern Alps. This is shown by a number of indicators, such as Certosa fibulae, situla art masterpieces and others, which are also the principal heralds of new times.¹⁵²⁸

This phase saw a substantial increase in the number of burials, particularly in Tumuli 2 and 13 at Preloge.¹⁵²⁹ Simultaneously, there was a significant rise in the number of armed members of the community (fig. 129). Their armament included socketed axes (fig. 46: 4–6, 8, 10), spears (fig. 48: 3, 6; 49: 2; 50: 2, 4) and knives with a narrow tang for a wooden mount (fig. 53: 1), which constituted the typical outfit of a Dolenjska warrior. Some warriors were additionally equipped with a varied collection of arrows, which predominantly included the so-called Scythian trilobate arrowheads (fig. 51).¹⁵³⁰ The local military elite boasted double-crested helmets, which were supposedly made in the workshops of Dolenjska (fig. 56: 4, 7–9).¹⁵³¹ Local production is evidenced by the unparalleled helmet with a ribbed skull (fig. 56: 10). Also from this phase is the Etruscan helmet of the Negova type, of Variant Volterra after Egg (fig. 59), though its Magdalenska gora provenance is only supposed.¹⁵³² Other symbols of power as well as a high social rank include maces (fig. 71: 6, 8),¹⁵³³ spits (fig. 73)¹⁵³⁴ and sets of bronze vessels consisting of situlae, cups, ladles and cists (fig. 130: a–c, e) offered to noteworthy men in their graves.¹⁵³⁵ The examples of bronze cists from Magdalenska gora are of roughly equal sizes, with a volume of about 29 litres. They belong, with their handles attached at mid-height, to the first group after Stjernquist, the production centre of which should be sought in the Bologna area.¹⁵³⁶ The grave groups also include pottery of very high quality made in Dolenjska

¹⁵²⁸ The products of the situla art from Magdalenska gora feature in numerous studies on the topic. In grave contexts are published in: Tecco Hvala/Dular/ Kocuvan 2004, T. 8: 8, 9: 3, 14: 3, 24: 3, 41: 1, 53: 1, 85: 17, 105: 1–6, Beil. 2–6, 9–12A, 13. On helmets and Certosa fibulae see Chapters 4.2 and 4.7.8.

¹⁵²⁹ Tecco Hvala/Dular/ Kocuvan 2004, Abb. 50.

¹⁵³⁰ Preloge, Gr. 2/13, 2/38, 13/5; see Chapter 4.1.2 on arrows.

¹⁵³¹ Preloge, Gr. 2/g, 2/13, 2/38, 13/119.

¹⁵³² See Chapter 4.2 on helmets.

¹⁵³³ Preloge, Gr. 2/13, 13/55.

¹⁵³⁴ Laščik, Gr. V/6–7–7a, Preloge, Gr. 2/b, 2/38; see Chapter 4.5 on maces and spits.

¹⁵³⁵ Laščik, Gr. V/6–7–7a, V/29; Preloge, Gr. 2/a, 2/b, 2/d, 2/k, 2/13, 2/38, 13/55, 13/119; Hencken 1978, Figs. 110f, 111, 139; Tecco Hvala/Dular/Kocuvan 2004, T. 7: 5, 8: 8, 9: 3, 12B: 1, 25: 12, 36: 27, 85: 16, 17, 108: 7. Apart from those, a bronze cist and an exceptional situla with rich figural decoration from Magdalenska gora are kept in the Logatec War Museum without data on the circumstances of recovery: Švajncer 2012, 5 ff.

¹⁵³⁶ Stjernquist 1988, 165, Abb. 88.

ražnji ali *oboloi* (sl. 73)¹⁵³⁴ in bronasti pivski servisi, tj. bronaste situle, kupa, zajemalka in ciste (sl. 130: a–c, e), ki so bili pridani častivrednim možem.¹⁵³⁵ Magdalen-

¹⁵³⁴ Laščik, gr. V/6–7–7a, Preloge, gr. 2/b, 2/38; glej poglavje 4.5 o žezlih in raznjih.

¹⁵³⁵ Laščik, gr. V/6–7–7a, V/29; Preloge, gr. 2/a, 2/b, 2/d, 2/k, 2/13, 2/38, 13/55, 13/119; Hencken 1978, Fig. 110f, 111, 139; Tecco Hvala/Dular/Kocuvan 2004, T. 7: 5, 8: 8, 9: 3, 12B: 1, 25: 12, 36: 27, 85: 16,17, 108: 7. K tem je treba prišteti še bronasto cisto in bogato figuravno okrašeno situlo, ki ju hrani Vojni muzej v Logatcu brez podatkov o odkritju: Švajncr 2012, 5 ss.

(clay footed bowls and bowls with indented walls), coated either with a fine glaze or with graphite.¹⁵³⁷ Some examples even had beautiful bronze lids (fig. 130: f–i).¹⁵³⁸

¹⁵³⁷ Tecco Hvala/Dular/Kocuvan 2004, T. 41: 6,7, 43: 13,14, 54A: 13, 112A: 3, 129: 46,47, 135: 21; see also Dular J. 1982, 46 f, 52 ff, 85, 151 ff, Abb. 4: C, T. 13: 124–126, 18: 154–159.

¹⁵³⁸ Tecco Hvala/Dular/Kocuvan 2004, T. 25: 13, 42: 10, 43: 12, 44A: 15. The bronze lids from Grave 2/46 at Preloge are decorated with embossed ribs and dots in the shape of rosettes. Parallels for such decoration can be found in Istriian *Nesactium*, Gr. 12/zone I (Mihovilič 1995, 289 ff, T. 9: 3,

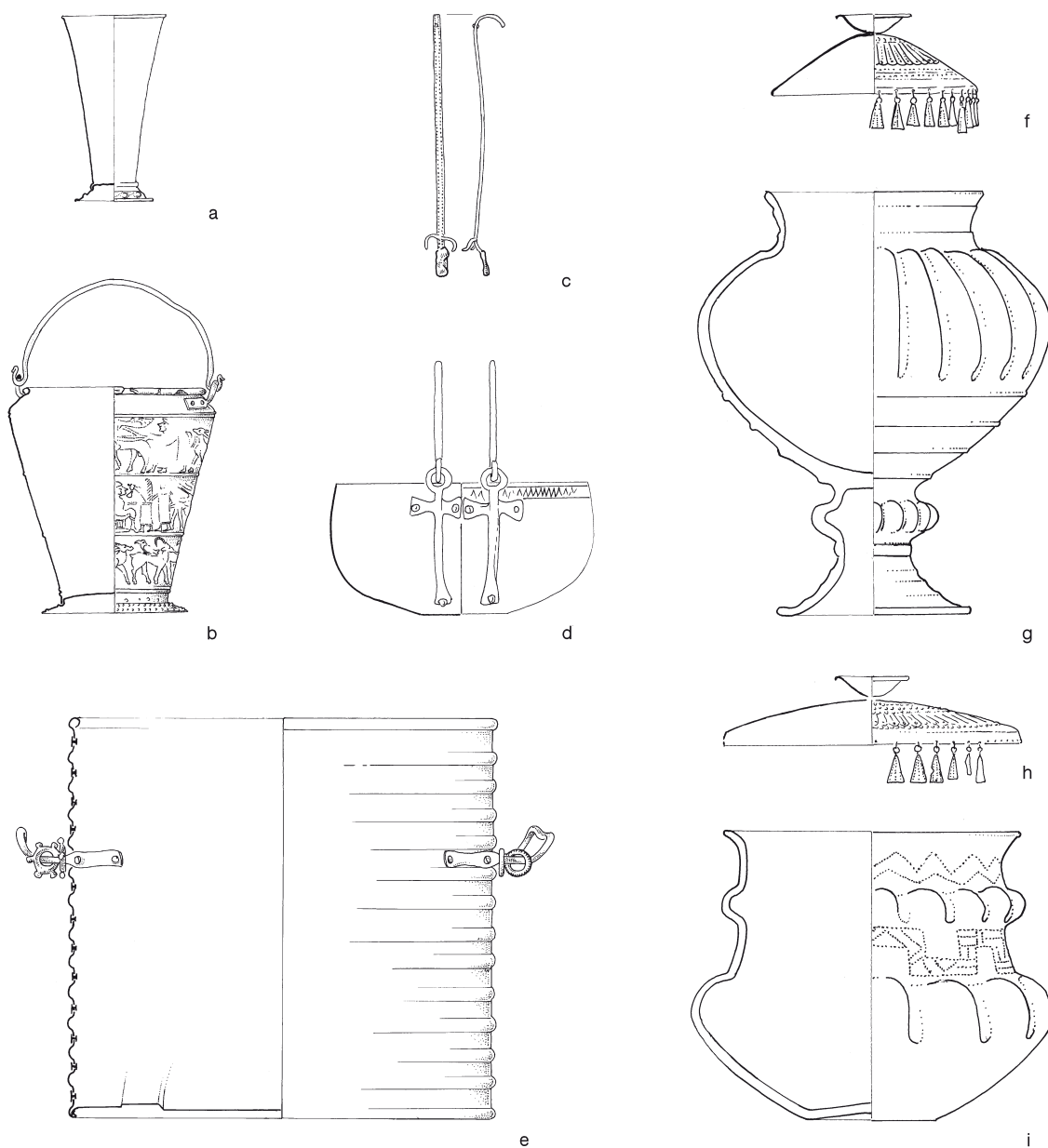

Sl. 130: Izbrano posodje iz moških grobov na Magdalenski gori. g, i = keramika, ostalo = bron. M. = 1:6.
Fig. 130: Select vessels from the male graves at Magdalenska gora. g, i = ceramic, rest = bronze. Scale = 1:6.
a – Preloge, gr. 2/38; b, e – Preloge, gr. 13/55; c, d – Preloge, gr. 2/13; f–i – Preloge, gr. 2/46.

skogorski primerki bronastih cist so približno enako veliki in so držali okoli 29 litrov, po fiksno pritrjenih ročajih na sredini oboda se uvrščajo v prvo skupino po Stjernquistovi, z izdelovalnim središčem na območju Bologne.¹⁵³⁶ Na drugi strani v teh grobnih sestavi nastopa zelo kvalitetna dolenska keramika (glineni ciboriji in sklede z nagubanim ostenjem), prevlečena s finim loščem ali grafitom;¹⁵³⁷ nekateri primerki so bili pokriti z lepimi bronastimi pokrovi (sl. 130: f-i).¹⁵³⁸ Prestiž so pomenili tudi konji, ki so bili pokopani skupaj z lastniki. Po morfoloških karakteristikah se uvrščajo v vzhodno skupino jezdnih konj;¹⁵³⁹ morda so jih dobavljali s panonsko-karpatskega območja, za kar bi govorile brzde tipa Szentes-Vekerzug po Parduczu (sl. 61: 3, 9). Konj iz groba 2/13 je imel okrasje za jermenje, ki spominja na skitsko-tračanski živalski stil spodnjega Podonavja (sl. 61: 10), pa tudi okrogle dvodelne diske (sl. 61: 11) s paralelami v južni Nemčiji;¹⁵⁴⁰ razen tega mu je bil pridan še bronast kotliček (sl. 130: d),¹⁵⁴¹ kar samo še podkrepljuje stremljenje njegovega lastnika k prestižu. Toda večine oboroženih pripadnikov ne moremo prištevati k vojaški eliti, prej bi jih lahko razvrstili v nekakšno vojaško formacijo, sestavljeno iz pehotnih enot s konjenico na čelu (sl. 55).¹⁵⁴² K standardni moški noši so spadale še pravokotne pasne spone (sl. 65 in 66: 2, 13),¹⁵⁴³ proti koncu te faze pa so začeli nositi tudi narokvice (sl. 114: 4, 6).¹⁵⁴⁴

Spekter fibul se je vnovič razširil; moški so jih običajno nosili v paru, ženske in otroci pa največkrat po eno.¹⁵⁴⁵ Navezava na starejše prototipe se odraža v dolenskem derivatu trortastih fibul, tj. tip Vinkov vrh oz. vrsta VII po Ogrinovi (sl. 84: 6, 7),¹⁵⁴⁶ ter v kačastih

Another item of prestige was a horse buried alongside its owner. The morphological traits of these horses rank them into the eastern group of riding horses.¹⁵³⁹ They may have been supplied from the Pannonian-Carpathian region, as indicated by the bridle-bits of Type Szentes-Vekerzug after Parducz (fig. 61: 3, 9). The horse in Grave 2/13 had strap decoration reminiscent of the Scythian-Thracian animal style products from the lower reaches of the Danube (fig. 61: 10), but also round double discs (fig. 61: 11) with parallels in southern Germany.¹⁵⁴⁰ Buried with the horse was also a small bronze cauldron (fig. 130: d),¹⁵⁴¹ which further confirms the aspirations for prestige on the part of its owner. The majority of the armed members of the Magdalenska gora community, however, did not form part of the military elite. Their varied equipment points towards a sort of a military formation composed of infantry units with cavalry at the forefront (fig. 55).¹⁵⁴² A standard piece of the male costume in Phase III is the rectangular belt clasp (fig. 65 and 66: 2, 13),¹⁵⁴³ while towards the end of the phase men also began wearing armlets (fig. 114: 4, 6).¹⁵⁴⁴

The range of fibulae again broadened. Usually, men wore them in pairs, while women and children wore them singly.¹⁵⁴⁵ A connection with earlier prototypes can be seen in the Dolenska derivative of the three-knobbed fibulae of Type Vinkov vrh or Type VII after Ogrin (fig. 84: 6, 7),¹⁵⁴⁶ but also in serpentine fibulae with a band bow curving into a loop (fig. 88: 7, 15).¹⁵⁴⁷ Newly appeared are the Certosa fibulae that spread from northern Italy. The first to come into fashion were those of Types II, V and I (fig. 94: 1-6, 8-10),¹⁵⁴⁸ while later the fibulae with a crossbow spring became popular, such as the Certosa fibulae of Type XIII (fig. 94: 7, 11, 15, 18,

¹⁵³⁶ Stjernquist 1988, 165, Abb. 88.

¹⁵³⁷ Tecco Hvala/Dular/Kocuvan 2004, T. 41: 6,7, 43: 13,14, 54A: 13, 112A: 3, 129: 46,47, 135: 21; glej še Dular J. 1982, 46 s, 52 ss, 85, 151 ss, sl. 4: C, T. 13: 124-126, 18: 154-159.

¹⁵³⁸ Tecco Hvala/Dular/Kocuvan 2004, T. 25: 13, 42: 10, 43: 12, 44A: 15. Pokrovi iz groba 2/46 s Prelog so okrašeni z iztolčenimi rebri v obliki rozete in obrobjeni z bunčicami. Paralele za ta okras najdemo v istrskem *Nezakciju*, gr. 12/*cona I* (Mihovilić 1995, 289 ss, T. 9: 3, 12: 3) ali na situli z *Mosta na Soči*, gr. 2837 (Marchesetti 1993, 221, T. II: 11).

¹⁵³⁹ Preloge, gr. IV/30, 2/13, 13/119; glej poglavje 1.1.3 o zooloških ostankih.

¹⁵⁴⁰ Glej poglavje 4.3 o konjski opremi.

¹⁵⁴¹ Tecco Hvala/Dular/Kocuvan 2004, T. 24: 11; Dular J. 2007, 744 s; Teržan 2011b.

¹⁵⁴² Glej poglavje 4.1 o orožju.

¹⁵⁴³ Laščik, gr. V/6-7-7a, Preloge, gr. II/2, VIII/6, X/51, X/77, 2/13, 2/38, 2/46, 2/47, 2/58, 2/62, 13/53, 13/55, 13/69,13/119, 13/153, *Voselca*, gr. 2/11; glej poglavje 4.4.2 o bronastih pravokotnih pasnih sponah.

¹⁵⁴⁴ Preloge, gr. 2/38, 2/47, 13/26, 13/53, 13/127; glej poglavje 4.9 o zapestnicah, narokvicah in nanožnicah.

¹⁵⁴⁵ Glej poglavji 4.7.8 o certoških ter 4.7.9 o figuralnih in samostrelnih fibulah.

¹⁵⁴⁶ Preloge, gr. I/2, IV/26, 13/46, *Voselca*, gr. 2/21; glej poglavje 4.7.4 o trortastih fibulah.

12: 3), on a situla from *Most na Soči*, Gr. 2837 (Marchesetti 1993, 221, T. II: 11).

¹⁵³⁹ Preloge, Gr. IV/30, 2/13, 13/119; see Chapter 1.1.3 on zoological remains.

¹⁵⁴⁰ See Chapter 4.3 on horse gear.

¹⁵⁴¹ Tecco Hvala/Dular/Kocuvan 2004, T. 24: 11; Dular J. 2007, 744 f; Teržan 2011b.

¹⁵⁴² See Chapter 4.1 on weapons.

¹⁵⁴³ Laščik, Gr. V/6-7-7a, Preloge, Gr. II/2, VIII/6, X/51, X/77, 2/13, 2/38, 2/46, 2/47, 2/58, 2/62, 13/53, 13/55, 13/69,13/119, 13/153, *Voselca*, Gr. 2/11; see Chapter 4.4.2 on bronze rectangular belt clasps.

¹⁵⁴⁴ Preloge, Gr. 2/38, 2/47, 13/26, 13/53, 13/127; see Chapter 4.9 on bracelets, anklets and armlets.

¹⁵⁴⁵ See Chapter 4.7.8 on Certosa fibulae and 4.7.9 on figural and crossbow fibulae.

¹⁵⁴⁶ Preloge, Gr. I/2, IV/26, 13/46, *Voselca*, Gr. 2/21; see Chapter 4.7.4 on three-knobbed fibulae.

¹⁵⁴⁷ Preloge, Gr. I/3a, X/4, 2/46, 2/62, 13/152, *Voselca*, Gr. 2/7; see Chapter 4.7.6 on serpentine fibulae.

¹⁵⁴⁸ Laščik, Gr. V/2, Preloge, Gr. II/10, IV/17, IV/22, IV/28, VII/24, IV/25, VII/41, VIII/6, VIII/10, X/14, X/23, X/50, X/51, X/67, X/75, 2/14, 2/15, 2/24, 2/30, 2/52, 2/53, 2/68, 2/83, 2/84, 13/6, 13/18, 13/36, 13/49, 13/54, 13/69, 13/153, *Voselca*, Gr. 2/9, 2/18, 2/20, 2/11.

fibulah s široko trakasto zanko (sl. 88: 7, 15).¹⁵⁴⁷ Nove so certoške fibule, ki so se razširile s severnoitalskega območja. Najprej so prišle v modo certoške fibule vrst II, V in I (sl. 94: 1–6, 8–10),¹⁵⁴⁸ pozneje pa so se uveljavile fibule s samostrelno peresovino, kot so certoške vrste XIII (sl. 94: 7, 11, 15, 18, 96: 10–14)¹⁵⁴⁹ ter figuralne z zaključkom noge v obliki naprej gledajoče pasje, konjske ali ovnove glavice (sl. 99: 4–6).¹⁵⁵⁰ V otroških oz. dekliških opravah tega časa zasledimo še figuralne fibule s ptico oz. račko na koncu noge in z lokom v obliki muce ali konjička in trovprege (sl. 99: 1–3).¹⁵⁵¹ Pojavijo se tudi fibule s pečatno nogo ali z jabolčastim zaključkom, domnevno okrašene s koralnimi vložki (sl. 99: 7, 8, 11),¹⁵⁵² ki predstavljajo severnoitalsko interpretacijo zahodnohalštatskih modelov.

Sestav ženske noše se tja od sredine prejšnje faze ni bistveno menjal, spremenila se je le paleta oblik. Obročasti nakit še naprej ostaja tista emblematična prvina, po kateri je prepoznavna magdalenskogorska in nasploh dolenjska noša. V tej fazi so pogostejše votle zapestnice (sl. 116: 3, 5, 6), ki so jih pripadnice te skupnosti nosile običajno na vsaki roki po eno in včasih v kompletu s parom votlih nanožnic ter skupaj z garniturami dveh, štirih ali šestih valjastih uhanov oz. lasnih obročkov (sl. 122: 12–16).¹⁵⁵³ Med otroškim okrasjem se pojavljajo masivni bronasti ali svinčeni torkvezi (sl. 101: 1, 6; 102: 6), medtem ko so votle ovratnice razen otrok nosile tudi odrasle osebe (102: 1, 4).¹⁵⁵⁴ Še vedno so bile zelo priljubljene jantarne ogrlice, toda povečini iz bolj drobnih jagod, kombinirane s steklenimi jagodami raznih oblik in barv (sl. 105: 6–9 in 107: 1, 6, 9). V polihromnem stilu se zrcalijo barvitost in svojski okus dolenjske kulturne sredine ter večine njenih steklarskih mojstrov. Izbranke so imele svečana ogrinjala z vtkanimi modrimi, belimi in rumenimi steklenimi perlicami (sl. 107: 10–13),¹⁵⁵⁵ njihov videz pa si lahko predstavljamo po upodobitvah situlske umetnosti. Ob

¹⁵⁴⁷ Preloge, gr. I/3a, X/4, 2/46, 2/62, 13/152, Voselca, gr. 2/7; glej poglavje 4.7.6 o kačastih fibulah.

¹⁵⁴⁸ Laščik, gr. V/2, Preloge, gr. II/10, IV/17, IV/22, IV/28, VII/24, IV/25, VII/41, VIII/6, VIII/10, X/14, X/23, X/50, X/51, X/67, X/75, 2/14, 2/15, 2/24, 2/30, 2/52, 2/53, 2/68, 2/83, 2/84, 13/6, 13/18, 13/36, 13/49, 13/54, 13/69, 13/153, Voselca, gr. 2/9, 2/18, 2/20, 2/11.

¹⁵⁴⁹ Laščik, gr. V/6–7–7a, V/23, Preloge, gr. II/2, IV/23, VI/30, VII/5, VII/24, VII/50, VIII/16, X/45, X/48, X/77, 2/4, 2/56, 13/45, 13/53, 13/55, 13/87, 13/117.

¹⁵⁵⁰ Laščik, gr. V/43, Preloge, gr. IV/30a, VI/30, X/48, X/50, 2/b, 13/53, 13/150, Voselca, gr. 2/11.

¹⁵⁵¹ Preloge, gr. II/15, 2/c, 2/o, 2/11.

¹⁵⁵² Laščik, gr. V/37, Preloge, gr. 2/55, 13/116, 13/153; glej poglavje 4.7.9 o figuralnih in samostrelnih fibulah.

¹⁵⁵³ Glej poglavji 4.9.2 o votlih zapestnicah in 4.10 uhanih.

¹⁵⁵⁴ Preloge, gr. 2/4, 2/14, 2/67, 13/54, 13/77, Voselca, gr. 2/7; glej poglavje 4.8.1 o ovratnicah.

¹⁵⁵⁵ Preloge, gr. 2/a, 2/n, 13/36, 13/97, 13/117. Podobna dragocena oblačila so znana tudi z daunijskih stel: D'Ercole 2000b, 329 ss, Fig.1–3; Negroni Catacchio 2007.

96: 10–14),¹⁵⁴⁹ but also fibulae with a forward-facing dog's, horse's or ram's head at the end of the foot (fig. 99: 4–6).¹⁵⁵⁰ The costume of children or girls further included zoomorphic fibulae or a fibula in the shape of a three-horse chariot (fig. 99: 1–3).¹⁵⁵¹ There were also fibulae with a stamped foot or with an apple-shaped foot terminal, supposedly decorated with coral inlays (fig. 99: 7, 8, 11),¹⁵⁵² which represent a north Italian interpretation of west Hallstatt models.

The composition of the female costume remained unaltered ever since the middle of the previous phase; what did change was the range of forms. Ring jewellery continued to be the emblematic element of both the Magdalenska gora and the Dolenjska costume. This phase revealed more hollow bracelets (fig. 116: 3, 5, 6), which women wore one on each hand and sometimes together with a matching pair of anklets as well as a set of two, four or six cylindrical ear- or hair-rings (fig. 122: 12–16).¹⁵⁵³ Children's jewellery included solid bronze or lead torques (fig. 101: 1, 6; 102: 6), but also hollow torques that were worn by adults as well (102: 1, 4).¹⁵⁵⁴ Amber necklaces continued to be popular, now mostly made of smaller beads combined with glass beads of various shapes and colours (fig. 105: 6–9 and 107: 1, 6, 9). This polychrome style is an expression of the colourful taste of the Dolenjska communities as well as the skill of their master glassmakers. Select women wore ceremonial clothes with blue, white and yellow glass beads sewn onto them (fig. 107: 10–13),¹⁵⁵⁵ the appearance of which can be imagined on the basis of the situla art depictions. Girls' jewellery further included items imported from the workshops in Italy or elsewhere in the Mediterranean, an example of which is the lost glass pendant in the shape of a human head (Gr. 2/11), supposedly similar to examples from Carthage and the eastern Mediterranean.¹⁵⁵⁶ A similar distribution is revealed by the glass ram's heads, which figure in the necklaces of the women of Magdalenska gora and Dolenjska in general (fig. 107: 9).¹⁵⁵⁷ Furthermore, the *oinochoe* and *kylix* from child's

¹⁵⁴⁹ Laščik, Gr. V/6–7–7a, V/23, Preloge, Gr. II/2, IV/23, VI/30, VII/5, VII/24, VII/50, VIII/16, X/45, X/48, X/77, 2/4, 2/56, 13/45, 13/53, 13/55, 13/87, 13/117.

¹⁵⁵⁰ Laščik, Gr. V/43, Preloge, Gr. IV/30a, VI/30, X/48, X/50, 2/b, 13/53, 13/150, Voselca, Gr. 2/11.

¹⁵⁵¹ Preloge, Gr. II/15, 2/c, 2/o, 2/11.

¹⁵⁵² Laščik, Gr. V/37, Preloge, Gr. 2/55, 13/116, 13/153; see Chapter 4.7.9 on figural and crossbow fibulae.

¹⁵⁵³ See Chapter 4.9.2 on hollow bracelets and 4.10 on earrings.

¹⁵⁵⁴ Preloge, Gr. 2/4, 2/14, 2/67, 13/54, 13/77, Voselca, Gr. 2/7; see Chapter 4.8.1 on torques.

¹⁵⁵⁵ Preloge, Gr. 2/a, 2/n, 13/36, 13/97, 13/117. Similar precious garments are known from Daunian stelae: D'Ercole 2000b, 329 ff, Figs.1–3; Negroni Catacchio 2007.

¹⁵⁵⁶ Tecco Hvala/Dular/Kocuvan 2004, 34; see Chapter 4.8.2 on glass necklaces.

¹⁵⁵⁷ Egg 2010, 525 ff, Abb. 6.

tem zasledimo v dekliškem nakitu posamične importe iz italjskih oz. sredozemskih delavnic, kot npr. izgubljeni stekleni obesek v podobi človeške glavice (gr. 2/11), ki naj bi bil soroden primerkom iz Kartagine in vzhodnega Sredozemlja.¹⁵⁵⁶ Podobno razprostranjenost kažejo tudi steklene ovnove glavice, ki nastopajo v ogrlicah magdalenskogorskih in drugih dolenskih predstavnic (sl. 107: 9).¹⁵⁵⁷ Iz južnoitaljskih delavnic domnevno izvira *oinochoe* in *kylix* iz otroškega groba 2/37 na Prelogah (sl. 131: c, d),¹⁵⁵⁸ ki sta v italjskem svetu spadala med ženske in dekliške atribute.¹⁵⁵⁹ Potrditev za to najdemo v likovnem pripovedništvu, in sicer na pasni sponi iz Este (Carceri 48), na kateri je upodobljena ženska z naglavnim ogrinjalom, ki v rokah drži vrč in dvoročajno posodico in ju podaja ležeči moški figuri.¹⁵⁶⁰ Nekaterim pripadnicam magdalenskogorske skupnosti je bilo pridano tudi bronasto posodje: pokojnica v grobu 2/a je imela dve bronasti situli – eno ornamentirano s figuralnimi prizori in drugo z žarnogrobiščno motiviko rac in koncentričnih krožcev (sl. 131: a), medtem ko je bil ženski v grobu 2/p pridani unikatni bronasti ciborij s figuralno okrašenim pokrovom (sl. 131: b).¹⁵⁶¹ Med ženskimi pridatki zasledimo mestoma še koščene oz. roževinaste tule z izrezljanim oz. vrezanim okrasom (sl. 131: g),¹⁵⁶² ki so se morda uporabljali kot nekakšne posodice (za dišave?), kar nakazuje primerka z ohranjenim držajem.¹⁵⁶³ Ti predmeti spominjajo na slonokoščene *pyxides* z italjskega prostora, kjer se prav tako pojavljajo v ženskih grobovih.¹⁵⁶⁴ Na severnoitaljskem območju najdemo primerjave še za sceptre (sl. 125: 7–12, 126), ki pričajo o vlogi žensk in deklic v kulturni sferi.¹⁵⁶⁵

¹⁵⁵⁶ Tecco Hvala/Dular/Kocuvan 2004, 34; glej poglavje 4.8.2 o steklenih ogrlicah.

¹⁵⁵⁷ Egg 2010, 525 ss, Abb. 6.

¹⁵⁵⁸ Frey 1969, 84; Kimmig 1974, 68; Kromer 1986, 6, Abb. 2: 1,2; Gabrovec 1992a, Abb. 13: 2,5; Teržan 1995b, 88, Abb. 13; Mihovilić 1995, 295.

¹⁵⁵⁹ D'Ercole 2000a; Amann 2000, 108 ss.

¹⁵⁶⁰ Lucke/Frey 1962, Abb. 5: 1, T. 21: 5; Frey 1969, 83 s; Tombolani 1987, 149 s, Fig. 280; Mastrocinque 1987, 142 s, Fig. 93.

¹⁵⁶¹ Tecco Hvala/Dular/Kocuvan 2004, T. 14C: 3, pril. 5, 10, 11. Podoben pokrov je znan iz koroškega *Waisenbergtumulus* 2: Gleirscher 2008b, 52 s, Abb. 15.

¹⁵⁶² *Preloge*, gr. 2/16, 4/3, 13/55, X/73, *Voselca*, gr. 1/2, 2/12: Hencken 1978, Fig. 358a,b; Tecco Hvala/Dular/Kocuvan 2004, T. 20D: 3,4, 65C: 4, 84: 14,15, 130A: 16,17, 134D: 11. Dva koščena valja sta inventarizirana med pridatki moškega groba 13/55, vendar sta verjetno pripadala zraven pokopani ženski, glede na to, da jih običajno zasledimo v ženskih grobovih (Ibid., 61 s, sl. 31).

¹⁵⁶³ *Magdalenska gora-Preloge*, gr. 4/3: Tecco Hvala/Dular/Kocuvan 2004, T. 65C: 4; *Vače*: Stare F. 1955a, T. 77: 1.

¹⁵⁶⁴ Glej npr. *Eroi e regine: Piceni Popolo d'Europa* 2001, 98 ss, Fig. 74, 230, kat. št. 344; Torelli (ur.) 2000, 216, 596, kat. št. 170.

¹⁵⁶⁵ *Preloge*, gr. 2/c, 13/36, 13/97; glej poglavje 4.11.1 o sceptrih.

Grave 2/37 at Preloge (fig. 131: c, d)¹⁵⁵⁸ were supposedly made in the south Italian workshops and represented, in Italy, women's or girls' attributes.¹⁵⁵⁹ A confirmation of the latter can be found in figural depictions, for example on a belt clasp from Este (Carceri 48), which shows a woman wearing a veil and holding a jug and a two-handled vessel in her hands extended towards a recumbent male figure.¹⁵⁶⁰ Some female members of the Magdalenska gora community were also offered bronze vessels in their graves. The woman buried in Grave 2/a, for example, had two bronze situlae, one decorated with figural scenes and the other with Urnfield culture motifs of ducks and concentric circles (fig. 131: a), while the woman buried in Grave 2/p had a unique bronze footed bowl with a lid that bore figural decoration (fig. 131: b).¹⁵⁶¹ The female grave goods further include bone or horn tubes with carved or incised decoration (fig. 131: g),¹⁵⁶² which may have been used as containers (possibly for spices), as indicated by two examples with a preserved handle.¹⁵⁶³ These objects are reminiscent of the ivory *pyxides* known from Italy, where they were also found in female graves.¹⁵⁶⁴ Another type of finds that reveals connections with north Italy is the sceptre (fig. 125: 7–12, 126), which indicates women's and girls' involvement in the cult sphere.¹⁵⁶⁵

In comparison to the previous phase, social differences now become more apparent. A considerable wealth was accumulated in this time by the members buried in Tumulus 2 at Preloge. This tumulus yielded the highest number of rich male grave groups and most of the situla art objects, as well as spits or *oboloi* and the most beautiful horse gear.¹⁵⁶⁶ The women buried in this tumulus wore precious clothes and various other luxury

¹⁵⁵⁸ Frey 1969, 84; Kimmig 1974, 68; Kromer 1986, 6, Abb. 2: 1,2; Gabrovec 1992a, Abb. 13: 2,5; Teržan 1995b, 88, Abb. 13; Mihovilić 1995, 295.

¹⁵⁵⁹ D'Ercole 2000a; Amann 2000, 108 ff.

¹⁵⁶⁰ Lucke/Frey 1962, Abb. 5: 1, T. 21: 5; Frey 1969, 83 f; Tombolani 1987, 149 f, Fig. 280; Mastrocinque 1987, 142 f, Fig. 93.

¹⁵⁶¹ Tecco Hvala/Dular/Kocuvan 2004, T. 14C: 3, Beil. 5, 10, 11. A similar lid is known from Carinthian *Waisenbergtumulus* 2: Gleirscher 2008b, 52 f, Abb. 15.

¹⁵⁶² *Preloge*, Gr. 2/16, 4/3, 13/55, X/73, *Voselca*, Gr. 1/2, 2/12: Hencken 1978, Fig. 358a,b; Tecco Hvala/Dular/Kocuvan 2004, T. 20D: 3,4, 65C: 4, 84: 14,15, 130A: 16,17, 134D: 11. Two such tubes are inventoried among the goods of male Grave 13/55, but probably belonged to the woman buried beside him. Such tubes usually appear in female graves (Ibid., 61 f, Abb. 31).

¹⁵⁶³ *Magdalenska gora-Preloge*, Gr. 4/3: Tecco Hvala/Dular/Kocuvan 2004, T. 65C: 4; *Vače*: Stare F. 1955a, T. 77: 1.

¹⁵⁶⁴ See, for example, *Eroi e regine: Piceni Popolo d'Europa* 2001, 98 ff, Figs. 74, 230, Cat. No. 344; Torelli (ed.) 2000, 216, 596, Cat. No. 170.

¹⁵⁶⁵ *Preloge*, Gr. 2/c, 13/36, 13/97; see Chapter 4.11.1 on sceptres.

¹⁵⁶⁶ Gr. 2/b, 2/g, 2/k, 2/13, 2/38, 2/46, 2/57, 2/58.

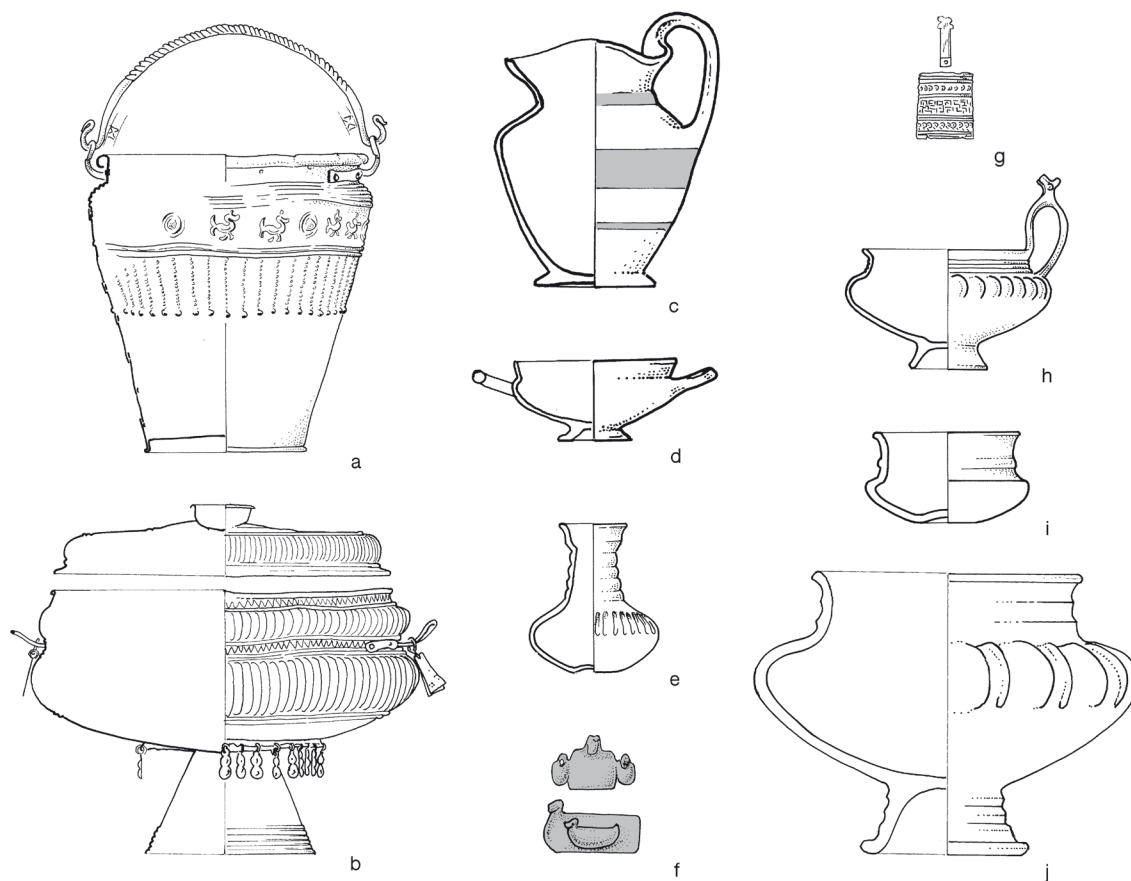

Sl. 131: Izbrano posodje iz ženskih grobov na Magdalenski gori. *a, b* = bron; *g* = kost; *ostalo* = keramika. M. = 1:6.
 Fig. 131: Select vessels from the female graves at Magdalenska gora. *a, b* = bronze; *g* = bone; *rest* = ceramic. Scale = 1:6.
a – Preloge, gr. 2/a; *b* – Preloge, gr. 2/p; *c, d* – Preloge, gr. 2/37; *e* – Preloge, gr. 2/32;
f – Voseca, gr. 2/6; *g, h* – Preloge, gr. 4/3; *i, j* – Preloge, gr. 13/50.

V primerjavi s prejšnjo fazo so družbene razlike zdaj bolj očitne. Precejšnje premoženje so si v tem času nakopičili pripadniki gomile 2 na Prelogah. Iz te gomile izvira največ bogatih moških oprav in večina izdelkov situlske umetnosti, prav tako različni oz. *oboloi* in najlepša konjska oprema.¹⁵⁶⁶ V njej so bile pokopane tudi izbranke v razkošnih oblačilih in z različnimi drugimi luksuznimi predmeti.¹⁵⁶⁷ Vse to priča o vodilni vlogi tega družinskega klana v gospodarskem, vojaškem in religioznem življenju, ne le na Magdalenski gori, temveč v vsej dolenski skupnosti. Po znanih podatkih se je le malokdo iz te regije lahko kosal z njimi. Na Magdalenski gori so se z njimi enačili člani starega rodu, ki so svoje umrle že dobri dve stoletji pokopavali v gomilo 13.¹⁵⁶⁸

items.¹⁵⁶⁷ All this reveals a leading role of the clan in the economic, military and religious life not only at Magdalenska gora, but in all of Dolenjska. Considering the data known thus far, hardly anyone from the region could match their wealth. At Magdalenska gora, only the members of the ancient family burying their dead in Tumulus 13 for over two centuries could match them in affluence.¹⁵⁶⁸

Prosperity and supremacy of the Magdalenska gora community was supposedly based on local crafts. This is suggested by the multitude of products made of sheet bronze (hollow bracelets, anklets, torques, cylindrical hair-rings, sceptres, rectangular belt clasps, possibly helmets), but also the Certosa fibulae of Type XIII and others. These elements, indicative of the Dolenjska costume, are represented with the highest number at Magdalenska gora. On the other hand, imports and

¹⁵⁶⁶ Gr. 2/b, 2/g, 2/k, 2/13, 2/38, 2/46, 2/57, 2/58.

¹⁵⁶⁷ Gr. 2/a, 2/c, 2/n, 2/p, 2/11, 2/37.

¹⁵⁶⁸ Gre za moška 13/55, 13/119 in ženska grobova 13/97, 13/117.

¹⁵⁶⁷ Gr. 2/a, 2/c, 2/n, 2/p, 2/11, 2/37.

¹⁵⁶⁸ I. e. men 13/55, 13/119 and women 13/97, 13/117.

Blaginja in premoč magdalenskogorske skupnosti sta domnevno temeljili na domači obrtni dejavnosti, čemur bi pritrjevala množica izdelkov iz bronaste pločevine (votle zapestnice, nanožnice, ovratnice, valjasti lasni obročki, verjetno tudi scepri, pravokotne pasne sponne, morda čelade) ter certoške fibule vrste XIII ipd. Te prvine, ki so indikativne za dolenjsko nošo, so najštevilčnejše zastopane prav na tem najdišču. Na drugi strani se v omenjenih uvoženih izdelkih in tujih vzorih zrcali vključenost Magdalenske gore v blagovno menjavo med skupnostmi v jadranskem in alpskem prostoru, ki se je vnovič razmahnila. Okrepili so se tudi stiki s Panonijo, kar bi lahko sklepali po konjih in konjski opremi, t. i. skitskih trirobih pušičnih osteh, kavljastih pasnih sponah (sl. 69: 1–3),¹⁵⁶⁹ skledah z apliciranimi rogatimi živalskimi glavicami na ročajih (sl. 131: h) in še čem.¹⁵⁷⁰ Za ilustracijo lahko zopet navedemo primer Donje Doline, kjer srečamo npr. votlo zapestnico variante Magdalenska gora, dolenjski tip tulaste sekire, zaščitne tulce za sulične osti, dolenjsko različico trortastih fibul (= tip Vinkov Vrh po Lo Schiavovi), samostrelno fibulo z naprej gledajočo konjsko glavico, certoške fibule vrst II, V in XIII ipd.,¹⁵⁷¹ kar govori v prid domnevi o trgovski poti, ki je tekla vzdolž reke Save ali po njej.¹⁵⁷²

FAZA V

Razcvetu je sledilo obdobje postopnih strukturnih sprememb in zatona, ko je Magdalenska gora začela dobivati čedalje bolj vojaški značaj. V tej fazi lahko opazimo izrazito prevlado grobov z orožjem (sl. 129), več je tudi skupinskih pokopov¹⁵⁷³ in takih brez pridakov.¹⁵⁷⁴

Ženska noša je v primerjavi s predhodno fazo skromnejša. Poleg votlih zapestnic¹⁵⁷⁵ in valjastih uhanov oz. lasnih obročkov, ki so zdaj obogateni z visečimi trikotnimi obeski (sl. 122: 17),¹⁵⁷⁶ so nosile še tanke polno ulite narebrene zapestne obroče¹⁵⁷⁷ in vzhodnoalpske živalske fibule (sl. 99: 19–21),¹⁵⁷⁸ ki so bile tedaj v modi v severovzhodnih pokrajinah. Proti koncu te faze

foreign models show that Magdalenska gora formed part of the flourishing trading network that involved communities in the Adriatic area and the Alps. Contacts with Pannonia were reinforced in this phase, as indicated by horses and their gear, but also the so-called Scythian trilobate arrowheads, hook belt clasps (fig. 69: 1–3),¹⁵⁶⁹ bowls with horned animal heads applied to the handles (fig. 131: h) and other finds.¹⁵⁷⁰ The site of Donja Dolina can again be used to illustrate the above connections, since it revealed a hollow bracelet of the Magdalenska gora variant, the Dolenjska type of a socketed axe, sheaths for spearheads, the Dolenjska variant of the three-knobbed fibulae (= Type Vinkov Vrh after Lo Schiavo), a crossbow fibula with a forward-facing horse's head, Certosa fibulae of Types II, V and XIII and others.¹⁵⁷¹ All this points to a trade route that ran either along or on the river Sava.¹⁵⁷²

PHASE V

The period of prosperity was followed by a time of gradual structural changes and of downfall, when Magdalenska gora became more and more militarized. Phase IV reveals a conspicuous predominance of graves with weapons (fig. 129). There are also more multiple burials¹⁵⁷³ as well as burials without grave goods.¹⁵⁷⁴

The female costume in this phase is poorer in comparison to that of Phase IV. Apart from the previously known hollow bracelets¹⁵⁷⁵ and cylindrical ear- or hair-rings, now additionally adorned by triangular pendants (fig. 122: 17),¹⁵⁷⁶ women also wore thin solid ribbed bracelets¹⁵⁷⁷ and East Alpine animal-headed fibulae (fig. 99: 19–21),¹⁵⁷⁸ which were fashionable in the region to the north-east. Towards the end of Phase V, the female costume came to include Certosa fibulae of Types VIIc, f, g (fig. 94: 19, 20),¹⁵⁷⁹ wire or thin ribbed bracelets with

¹⁵⁶⁹ See Chapter 4.4.3 on hook belt clasps with a central bar.

¹⁵⁷⁰ Dular J. 1982, 86, 143 f, Abb. 27; Tankó 2005, 154 s (Typ B = Type Novo mesto), Figs. 1, 2, 5.

¹⁵⁷¹ Marić 1964, T. 11: 5,12, 13: 18,21,25,27,29, 14: 14, 15: 1,26,28, 17: 27.

¹⁵⁷² Dular J. 2009b; Šašel Kos 2009.

¹⁵⁷³ Laščik, Gr. V/13–14, V/19–20, V/29, Preloge, Gr. X/21–21a, X/32–33; see Chapter 3.2.3 on multiple burials.

¹⁵⁷⁴ Preloge, gr. X/1, X/3, X/5, X/6, X/7, X/8, X/9, X/11, X/15a, X/17, X/19, 13/167; see Chapter 3.3.1 on graves without grave goods.

¹⁵⁷⁵ Preloge, Gr. VI/8, VI/33a, VIII/4.

¹⁵⁷⁶ Preloge, Gr. II/4, IV/19, 13/96.

¹⁵⁷⁷ Preloge, Gr. 2/40, VI/33a, X/36, Voselca, Gr. 2/17.

¹⁵⁷⁸ Laščik, Gr. V/36, Preloge, Gr. 2/40, 2/80, IV/19, VI/8, VI/33a, VI/34, VIII/4, X/36, 13/65, Voselca, Gr. 2/17; see Chapter 4.7.9 on crossbow fibulae.

¹⁵⁷⁹ Preloge, Gr. II/4, V/4, VII/27, VIII/38, 2/72, 13/79; see Chapter 4.7.8 on Certosa fibulae.

¹⁵⁶⁹ Glej poglavje 4.4.3 o kavljastih pasnih sponah.

¹⁵⁷⁰ Dular J. 1982, 86, 143 s, sl. 27; Tankó 2005, 154 s (Typ B = Novo mesto type), Fig. 1, 2, 5.

¹⁵⁷¹ Marić 1964, T. 11: 5,12, 13: 18,21,25,27,29, 14: 14, 15: 1,26,28, 17: 27.

¹⁵⁷² Dular J. 2009b; Šašel Kos 2009.

¹⁵⁷³ Laščik, gr. V/13–14, V/19–20, V/29, Preloge, gr. X/21–21a, X/32–33; glej poglavje 3.2.3 o skupnih pokopih.

¹⁵⁷⁴ Preloge, gr. X/1, X/3, X/5, X/6, X/7, X/8, X/9, X/11, X/15a, X/17, X/19, 13/167; glej poglavje 3.3.1 o grobovih brez pridakov.

¹⁵⁷⁵ Preloge, gr. VI/8, VI/33a, VIII/4.

¹⁵⁷⁶ Preloge, gr. II/4, IV/19, 13/96.

¹⁵⁷⁷ Preloge, gr. 2/40, VI/33a, X/36, Voselca, gr. 2/17.

¹⁵⁷⁸ Laščik, gr. V/36, Preloge, gr. 2/40, 2/80, IV/19, VI/8, VI/33a, VI/34, VIII/4, X/36, 13/65, Voselca, gr. 2/17; glej poglavje 4.7.9 o samostrelnih fibulah.

se v njihovi noši pojavijo certoške fibule vrste VIIc, f, g (sl. 94: 19, 20),¹⁵⁷⁹ žičnate ali tanke narebrenne zapestnice z zakovičenimi konci (sl. 111: 9)¹⁵⁸⁰ ter žičnati uhani s pentljami (sl. 122: 18).¹⁵⁸¹

Novosti, ki so zaznamovale moške oprave tega časa, govorijo predvsem o vplivih iz novih centrov moči, ki so se formirali v severozahodnem alpskem svetu in z njimi latenska kultura. V oborožitvi magdalenskogorskih bojevnikov se pojavijo dvorezni meči (sl. 52: 5, 6),¹⁵⁸² bojni noži s koščnim ročajem (sl. 53: 4, 5)¹⁵⁸³ in kratka kopja (sl. 50),¹⁵⁸⁴ s čimer se je deloma spremenil tudi način bojevanja. V zgodnjelatenski kulturi lahko iščemo poreklo še za posamezne oblike in izvedbe pasnih spon in fibul, denimo za majhne sponne trikotne sheme, izdelane iz železa ali bronu v predrti tehniki (sl. 69: 6–15),¹⁵⁸⁵ za pavkaste oz. dvoploščičaste fibule (sl. 99: 13–18)¹⁵⁸⁶ ter fibule t. i. zgodnjelatenske sheme.¹⁵⁸⁷ Sicer pa so moški v tem času uporabljali predvsem certoške fibule vrst IX, X in XI ter železne izvedbe (sl. 94: 13, 14 in sl. 96: 1–9, 15, 16).¹⁵⁸⁸ Nekateri so nosili celo amulete, kot bi lahko interpretirali konjske ali pasje zobe, del kozjega roga in medvedji kremplj, ki so bili najdeni na prsnem predelu okostij in so največkrat preluknjani.¹⁵⁸⁹ V moški noši se pojavljajo tudi spiralne (sl. 114: 3, 5)¹⁵⁹⁰ in svinčene narokvice (sl. 119),¹⁵⁹¹ za slednje bi lahko iskali pobudo v primerkih iz sapropelita v zgodnjelatenskih moških opravah na srednjeevropskem prostoru.¹⁵⁹² Dolenjsko so ti vplivi dosegli domnevno iz dveh smeri – z zahoda, prek Padske nižine oz. južnega obrobja Alp, in s severa,

riveted ends (fig. 111: 9)¹⁵⁸⁰ and wire earrings with loops (fig. 122: 18).¹⁵⁸¹

The novelties that marked the male outfit of this phase speak primarily of influences coming from the new centres of power formed in the north-western Alps and with them from the La Tène culture. The armament of the warriors of Magdalenska gora came to include double-edged swords (fig. 52: 5, 6),¹⁵⁸² battle knives with a bone mount (fig. 53: 4, 5)¹⁵⁸³ and javelins (fig. 50),¹⁵⁸⁴ which indicates a change in the manner of combat. The Early La Tène culture may also be the origin of certain forms of belt clasps and fibulae, for instance of the small openwork clasps of a triangular scheme made either of iron or bronze (fig. 69: 6–15),¹⁵⁸⁵ of kettledrum or disc-shaped fibulae – *Doppelpauken-*, *Alpine Blechpaukenfibeln* (fig. 99: 13–18)¹⁵⁸⁶ as well as of the fibulae of the Early La Tène scheme.¹⁵⁸⁷ The male costume of this phase mainly included Certosa fibulae of Types IX, X and XI, as well as iron examples (fig. 94: 13, 14 and fig. 96: 1–9, 15, 16).¹⁵⁸⁸ Some men apparently used horse or dog teeth, part of a goat's horn and bear claws as amulets.¹⁵⁸⁹ Men also wore spiral (fig. 114: 3, 5)¹⁵⁹⁰ or lead armlets (fig. 119).¹⁵⁹¹ The latter could be seen as echoes of the armlets of sapropelite that formed part of the Early La Tène male outfit in the central European area.¹⁵⁹² La Tène influences are supposed to have reached Dolenjska from two directions – from the west, across the Po Plain or the southern fringes of the Alps, and from the north, along the Alpine valleys.¹⁵⁹³ However, with

¹⁵⁷⁹ *Preloge*, gr. II/4, V/4, VII/27, VII/38, 2/72, 13/79; glej poglavje 4.7.8 o certoških fibulah.

¹⁵⁸⁰ *Preloge*, gr. II/4, V/4, 13/79; glej poglavje 4.9.2 o brosnatih zapestnicah.

¹⁵⁸¹ *Preloge*, gr. IV/41, 13/43; glej poglavje 4.10 o uhanih.

¹⁵⁸² Glej poglavje 4.1.3 o mečih.

¹⁵⁸³ *Laščik*, gr. V/12, V/15, V/21, V/41, *Preloge*, gr. IV/32, IV/52, VI/32, VII/23, X/21a, X/25, X/64, 2/69, 13/60.

¹⁵⁸⁴ *Laščik*, gr. V/12, V/19–20, V/26a, V/39, V/41, *Preloge*, gr. IV/32, IV/55, IV/93, VI/17, VI/29, VI/32, VII/11, VII/23, VIII/15, X/46, X/64, 2/1–2, 2/41, 2/47, 2/71, 13/40, 13/56; glej poglavje 4.1 o orožju.

¹⁵⁸⁵ *Laščik*, gr. V/5, *Preloge*, gr. 2/71, 13/63, VI/39, X/32–33; glej poglavje 4.4.3 o predrtih pasnih sponah.

¹⁵⁸⁶ *Preloge*, gr. 2/42, IV/41, VII/10, 13/1; glej poglavje 4.7.9 o samostrelnih fibulah.

¹⁵⁸⁷ Hencken 1978, Fig. 114e, 274d, 355a; Tecco Hvala/Dular/Kocuvan 2004, T. 138: 20.

¹⁵⁸⁸ *Preloge*, gr. 2/3, VI/12, VII/13, VII/14, VII/19, VII/44, X/20, X/21a, X/32–33, X/64, 13/37, 13/60, 13/64, 13/114, 13/132; *Voselca*, gr. 2/23.

¹⁵⁸⁹ *Laščik*, gr. V/5, V/11, *Preloge*, gr. 2/69, VII/51, X/18, X/28, 13/132; glej poglavje 3.2.4 o živalskih ostankih v grobnem kultu.

¹⁵⁹⁰ *Laščik* gr. V/29, *Preloge*, gr. 2/6, IV/38, VII/15, VII/19, 13/114.

¹⁵⁹¹ *Preloge*, gr. 2/j, 2/3, 2/5, 2/8, VI/42, X/18, X/21a, X/25, X/64.

¹⁵⁹² Glej poglavje 4.9 o zapestnicah in narokvicah.

¹⁵⁸⁰ *Preloge*, Gr. II/4, V/4, 13/79; see Chapter 4.9.2 on bronze bracelets.

¹⁵⁸¹ *Preloge*, Gr. IV/41, 13/43; see Chapter 4.10 on earrings.

¹⁵⁸² See Chapter 4.1.3 on swords.

¹⁵⁸³ *Laščik*, Gr. V/12, V/15, V/21, V/41, *Preloge*, Gr. IV/32, IV/52, VI/32, VII/23, X/21a, X/25, X/64, 2/69, 13/60.

¹⁵⁸⁴ *Laščik*, Gr. V/12, V/19–20, V/26a, V/39, V/41, *Preloge*, Gr. IV/32, IV/55, IV/93, VI/17, VI/29, VI/32, VII/11, VII/23, VIII/15, X/46, X/64, 2/1–2, 2/41, 2/47, 2/71, 13/40, 13/56; see Chapter 4.1 on weapons.

¹⁵⁸⁵ *Laščik*, Gr. V/5, *Preloge*, Gr. 2/71, 13/63, VI/39, X/32–33; see Chapter 4.4.3 on open-work belt hooks.

¹⁵⁸⁶ *Preloge*, Gr. 2/42, IV/41, VII/10, 13/1; see Chapter 4.7.9 on crossbow fibulae.

¹⁵⁸⁷ Hencken 1978, Figs. 114e, 274d, 355a; Tecco Hvala/Dular/Kocuvan 2004, T. 138: 20.

¹⁵⁸⁸ *Preloge*, Gr. 2/3, VI/12, VII/13, VII/14, VII/19, VII/44, X/20, X/21a, X/32–33, X/64, 13/37, 13/60, 13/64, 13/114, 13/132; *Voselca*, Gr. 2/23.

¹⁵⁸⁹ *Laščik*, Gr. V/5, V/11, *Preloge*, Gr. 2/69, VII/51, X/18, X/28, 13/132; see Chapter 3.2.4 on animal remains in the funerary cult.

¹⁵⁹⁰ *Laščik* Gr. V/29, *Preloge*, Gr. 2/6, IV/38, VII/15, VII/19, 13/114.

¹⁵⁹¹ *Preloge*, Gr. 2/j, 2/3, 2/5, 2/8, VI/42, X/18, X/21a, X/25, X/64.

¹⁵⁹² See Chapter 4.9 on bracelets and armlets.

¹⁵⁹³ Frey 1987; Pauli 1991, 215 ff (Karte); Guštin 2001, 11 ff; *id.* 2005, 50 ff.

prek alpskih dolin.¹⁵⁹³ Vendar razen posameznih fibul in redkih primerkov dvoreznih mečev, ki za zdaj predstavljajo edine tovrstne najdbe v jugovzhodnih Alpah, bi v njih težko videli importe, marveč prej lokalne posnetke tujih modelov. Na drugi strani o lokalni ustvarjalnosti in tradiciji pričajo pravokotne pasne spono iz tanke bronaste pločevine (sl. 66: 5, 20)¹⁵⁹⁴ in tulaste sekire (sl. 46: 9, 12),¹⁵⁹⁵ ki so ostale v uporabi. Poleg teh so izdelovali še sekire z enostranskimi plavutmi (sl. 46: 21–26)¹⁵⁹⁶ in uhate sekire (sl. 46: 15–20),¹⁵⁹⁷ ki so prav tako produkt jugovzhodnoalpskega sveta.

V tej fazi so vodilno vlogo prevzeli pripadniki gomile V na Laščiku, kar kažejo najprestižnejši moški pokopi s konji, čeladami in servisi bronastega posodja. Najbogatejši pokop predstavlja grob V/29 z negovskima čeladama in dvoreznim mečem (sl. 54: *desno spodaj*).¹⁵⁹⁸ Veljakoma, pokopanima z najvišjimi častmi v osrednjem delu gomile, so bili žrtvovani štirje konji, kar ni ravno pogost primer v dolenski kulturni sredini.¹⁵⁹⁹ Običajno je bil s konjenikom pokopan le en konj, ki mu je služil za ježo, medtem ko pokop štirih konjev asociira na vprego, čeprav o (bojnem) vozu ni ohranjenih sledi; so pa vozovi – tako dvokolesni kot štirikolesni – znani s situlskih prizorov.¹⁶⁰⁰ H konjem iz groba V/29 so spadale brzde in jermensko okrasje (sl. 61: 13–17),¹⁶⁰¹ izdelano v dolenskem delavniškem krogu; enako velja za bronasta kotlička s križnimi atašami, ki sta jima bila pridana.¹⁶⁰² Povezava konj s kotlički je pogosta,¹⁶⁰³ izpričana je tudi v likovnem pripovedništvu situlske umetnosti.¹⁶⁰⁴

¹⁵⁹³ Frey 1987; Pauli 1991, 215 ss (karta); Guštin 2001, 11 ss; id. 2005, 50 ss.

¹⁵⁹⁴ Laščik, gr. V/29, V/26a, *Preloge*, gr. IV/52, VII/44, X/25, X/46, 2/j, 2/42, 2/47, 13/84; glej poglavje 4.4.2 o bronastih pasnih sponah.

¹⁵⁹⁵ *Preloge*, gr. VI/12, VI/32, VII/13, VII/19, VII/44, X/18, X/21a, X/25, X/32–33, X/46, 2/3, 2/42, 2/47, 2/60, 2/77, 13/63, 13/64, 13/84, 13/114, 13/132.

¹⁵⁹⁶ Laščik, gr. V/8, V/19–20, *Preloge*, gr. IV/58, VI/29, VI/39, VII/11, VII/23, X/64, 2/41, 2/49, 2/69.

¹⁵⁹⁷ Laščik, V/9, V/11, *Preloge*, gr. 2/1–2, 2/6, 2/45, 2/71, 13/37, 13/40, 13/60, VII/15.

¹⁵⁹⁸ Hencken 1978, 36–38, Fig. 135–149.

¹⁵⁹⁹ Dular J. 2007b, sl. 1. Le v *Stični* sta bila ob grobu 48/33 s kamnito kamro pokopana dva konja, eden na vzhodni (gr. 48/31), drugi pa na južni strani (gr. 48/32); glej Gabrovec et al. 2006, 39, sl. 14. Morda je šlo za podoben primer še v *Brezju* v gomili 6, kjer so zabeleženi trije pokopi konjev v *grobvih* 6/1, 6/2, 6/3; glej Dular/Križ 1990, 537.

¹⁶⁰⁰ Npr. na situlah z *Vač*, *Dolenskih Toplic* in *Novega mesta*: Stare F. 1955a, pril. 1; Teržan 1976, pril. 3; Križ 1997, pril. 3; Turk 2005, sl. 44, 50, 52; Teržan 2011b.

¹⁶⁰¹ Glej poglavje 4.3 o konjski opremi.

¹⁶⁰² Hencken 1978, Fig. 135.

¹⁶⁰³ Dular J. 2007b, 744 s.

¹⁶⁰⁴ Lucke/Frey 1962, T. 66 (v zgornjem frizu na cisti iz *Moritzinga*), T. 75 (na situli iz *Kuffarna*) in morda tudi T. 63 (na situli *Arnoaldi* v zgornjem frizu levo med nogami konjev). Glej Teržan 2011b.

the exception of individual fibulae and rare examples of double-edged swords that for now represent the only finds of this kind in the south-eastern Alps, these objects could not be seen as imports, but rather as local imitation of foreign models. The local creativity and tradition, on the other hand, is evidenced by the rectangular belt clasps made of thin sheet bronze (fig. 66: 5, 20)¹⁵⁹⁴ and by the socketed axes (fig. 46: 9, 12),¹⁵⁹⁵ which remained in use. The local workshops also produced one-sided winged (fig. 46: 21–26)¹⁵⁹⁶ and shaft-hole axes (fig. 46: 15–20),¹⁵⁹⁷ the origin of which is also to be sought on south-eastern Alpine soil.

The leading role in this phase was played by the members of Tumulus V at Laščik, as can be discerned from the burials of prestige, of men with horses, helmets and sets of bronze vessels. The richest among them is Grave V/29 with two Negova helmets and a double-edged sword (fig. 54: *bottom right*).¹⁵⁹⁸ Two dignitaries were buried with the highest honours in this central grave, together with four sacrificed horses, which is not a common practice within the Dolenska community.¹⁵⁹⁹ Usually, a warrior was buried with a single horse, the one he had used for riding. The burial of four horses can be associated with a chariot drawn by four horses; no (battle) chariot remains have been preserved, though chariots, both two- and four-wheeled, are known from situla art depictions.¹⁶⁰⁰ The horses in Grave V/29 were equipped with bridle-bits and strap decorations (fig. 61: 13–17)¹⁶⁰¹ produced in the workshops of Dolenska. The same goes for the two cauldrons with double handles and cross-shaped attachments placed alongside the horses.¹⁶⁰² The combination of cauldrons and horses is

¹⁵⁹⁴ Laščik, Gr. V/29, V/26a, *Preloge*, gr. IV/52, VII/44, X/25, X/46, 2/j, 2/42, 2/47, 13/84; see Chapter 4.4.2 on bronze belt clasps.

¹⁵⁹⁵ *Preloge*, Gr. VI/12, VI/32, VII/13, VII/19, VII/44, X/18, X/21a, X/25, X/32–33, X/46, 2/3, 2/42, 2/47, 2/60, 2/77, 13/63, 13/64, 13/84, 13/114, 13/132.

¹⁵⁹⁶ Laščik, Gr. V/8, V/19–20, *Preloge*, Gr. IV/58, VI/29, VI/39, VII/11, VII/23, X/64, 2/41, 2/49, 2/69.

¹⁵⁹⁷ Laščik, V/9, V/11, *Preloge*, Gr. 2/1–2, 2/6, 2/45, 2/71, 13/37, 13/40, 13/60, VII/15.

¹⁵⁹⁸ Hencken 1978, 36–38, Figs. 135–149.

¹⁵⁹⁹ Dular J. 2007b, Abb. 1. Two horse burials are known from *Stična* (Gr. 48/31, 48/32). One of the horses was buried in the eastern part of male Grave 48/33 with a stone chamber, while the other one was found in the southern part: see Gabrovec et al. 2006, 39, Abb. 14. A similar situation can be observed at *Brezje*, in Tumulus 6 that contained three horse burials (Gr. 6/1, 6/2, 6/3): see Dular/Križ 1990, 537.

¹⁶⁰⁰ See, for example, situlae from *Vače*, *Dolenske Toplice* and *Novo mesto*: Stare F. 1955a, App. 1; Teržan 1976, Beil. 3; Križ 1997, App. 3; Turk 2005, figs. 44, 50, 52; Teržan 2011b.

¹⁶⁰¹ See Chapter 4.3 on horse gear.

¹⁶⁰² Hencken 1978, Fig. 135.

V tej gomili je bil odkrit še drug grob dveh vojščakov (V/19–20), morda bojnih tovarišev ali pobratimov, s katerima je bil najden zgodnjelatenski meč (*sl.* 52: 6, 8). Zaključek nožnice s tremi vdolbinicami (za korale?) po obliki spominja na zgodnjelatenske primerke iz srednjega Porenja (Hochscheid, Bescheide). Tam lahko najdemo še najboljše primerjave za okrogel okrask z zlato prevleko čez bronasto in železno podlogo, ki je spadal zraven. Podoben okrask (*sl.* 52: 7) je vseboval tudi tretji magdalenskogorski grob z mečem (V/26a). Ob tem se zastavlja vprašanje, kako so se ti meči znašli na Magdalenski gori, ali po trgovski poti ali morda z najemniki v tuji vojski?

Med najbogatejše magdalenskogorske pokope se uvršča še grob konjenika V/6–7a–7, katerega datacija ni najbolj jasna. Goldberg je o njem zapisal, da je vseboval dvogrebenasto čelado v slabem stanju, objavljen pa je del krajca negovske čelade; razen tega govori o zdrobljeni bronasti situli in nič o tem, da bi bila okrašena, medtem ko v objavi nastopa dokaj dobro ohranjen primerek s figuralnim okrasom v poznem situlskem stilu.¹⁶⁰⁵ Po preostalih pridatkih bi ta grob lahko spadal na konec prejšnje faze oz. že v certoško stopnjo.

Negovske čelade "slovenskega" oz. jugovzhodno-alpskega tipa (*sl.* 56: 11, 12)¹⁶⁰⁶ so bile znak dolenskih suverenov tega časa, ki pa niso imeli več enakovrednih naslednikov. Sledili so skromni pokopi, pogosto z enim ali dvema kosoma orožja (sekiro in kopjem ali bojnim nožem).¹⁶⁰⁷ Krizne razmere prav tako naznanjajo skeleti brez pridatkov, ki so ležali na obrobju gomil, mestoma vseprek in brez pravega reda (*sl.* 40).¹⁶⁰⁸

FAZA VI

V začetku 3. st. pr. n. št. se je s prihodom keltskih plemen z vzhoda in severovzhoda kulturna podoba Dolenjske korenito spremenila. Na tem prostoru se je izoblikovala nova kulturna entiteta, ki je arheološko označena kot mokronoška skupina. Z njo je docela prevladal žgani pokop v plana grobišča, v pridatkih pa keltski značaj.¹⁶⁰⁹

Kaj se je takrat dogajalo na Magdalenski gori, ni znano. V tamkajšnjih gomilah zasledimo posamične pokope šele iz poznolatske stopnje Mokronog IIIa, ki so mestoma poškodovali grobove iz mlajšega halštatskega obdobja.¹⁶¹⁰ Ali je bila obljudena v srednje-

frequent,¹⁶⁰³ and also appears on objects of the situla art.¹⁶⁰⁴

Tumulus V revealed another grave of two warriors (V/19–20), possibly brothers-in-arms, buried with an Early La Tène sword (*fig.* 52: 6, 8). Its scabbard chape with three hollows (for coral inlays?) is reminiscent in its form of the Early La Tène examples from the middle Rhineland (Hochscheid, Bescheide). The latter region also provided the best analogies for the gilded decorative element in the shape of a disc and with iron core, which belonged to the above-mentioned sword. A similar decorative element (*fig.* 52: 7) was found in the third grave with a sword (V/26a). It is not known whether these objects came to Magdalenska gora as a trade item or as part of the equipment of mercenaries.

Ranking among the Magdalenska gora elite was a horseman buried in Grave V/6–7a–7. Goldberg wrote that the grave contained a double-crested helmet in a poor state of preservation, while the publication lists a brim fragment of a Negova helmet. Moreover, Goldberg documented a crushed bronze situla without mentioning its decoration, while the publication presents a fairly well preserved situla with figural decoration in a late situla art style.¹⁶⁰⁵ The remaining grave goods date the grave to the end of the previous i.e. Certosa phase.

Negova helmets of the "Slovenian" or south-eastern Alpine type (*fig.* 56: 11, 12)¹⁶⁰⁶ were the distinguishing mark of the Dolenjska sovereigns of this phase. These, however, had no worthy successors. What followed were poor burials, often with one or two pieces of armament (axe, lance or battle knife).¹⁶⁰⁷ Also speaking for a time of crisis are inhumations without grave goods, lying along the edges of tumuli, sometimes in a haphazard manner (*fig.* 40).¹⁶⁰⁸

PHASE VI

The arrival of the Celtic tribes from the east and the north-east in the beginning of the third century BC significantly altered the cultural identity of Dolenjska. A new entity formed, archaeologically identified as the Mokronog group. It brought with it cremation burial in flat cemeteries, which came to dominate over the

¹⁶⁰³ Dular J. 2007b, 744 f.

¹⁶⁰⁴ Lucke/Frey 1962, T. 66 (in the upper frieze of the bronze cist from *Moritzing*), T. 75 (on the situla from *Kuffarn*) and possibly also T. 63 (on the *Arnoaldi* situla, in the upper frieze, between the horses' legs on the left). See Teržan 2011b.

¹⁶⁰⁵ Hencken 1978, 30 f, Figs. 108–112.

¹⁶⁰⁶ See Chapter 4.2 on Negova helmets.

¹⁶⁰⁷ *Laščik, Gr. V/8, V/9, V/10, V/12, V/41, Preloge, Gr. IV/54, IV/55, IV/58, VII/8, VII/11, VII/13, VII/14, VII/15, VII/23, 2/6, 13/37, 13/40, 13/56.*

¹⁶⁰⁸ See Chapter 3.3.1 on graves without grave goods.

¹⁶⁰⁵ Hencken 1978, 30 s, Fig. 108–112.

¹⁶⁰⁶ Glej poglavje 4.2 o negovskih čeladah.

¹⁶⁰⁷ *Laščik, gr. V/8, V/9, V/10, V/12, V/41, Preloge, gr. IV/54, IV/55, IV/58, VII/8, VII/11, VII/13, VII/14, VII/15, VII/23, 2/6, 13/37, 13/40, 13/56.*

¹⁶⁰⁸ Glej poglavje 3.3.1 o grobovih brez pridatkov.

¹⁶⁰⁹ Gabrovec 1966c; Guštin 1977; id. 1984; Božič 1987; id. 1999.

¹⁶¹⁰ *Laščik, Tum. 4 in gr. V/5, V/10, V/42; Preloge, Tum. I, II ali III in gr. VII/7, VII/31, VIII/13, X/55, X/78, 2/e+f, 2/9, 2/10, 2/12, 2/29, 2/41, 2/45, 2/49, 2/71; Hencken 1978, Fig.*

latenskem obdobju, ali so takrat nemara pokopavali na planih grobiščih kje v bližini, kakšna je bila njena vloga v poznolatskem obdobju, kako se je upirala rimskim osvajalcem, vse to so vprašanja, na katera lahko dajo odgovor le nadaljnja terenska raziskovanja ter izkopavanja na naselju in v bližnji okolici. Doslej je bilo med krajema Paradišče in Sap ob jugozahodnem vznožju Magdalenske gore odkrito le grobišče iz rimskih časov.¹⁶¹¹

Če strnemo poglobitve razvojne poteze magdalenskogorske skupnosti, bi lahko dejali, da je v prvi fazi predstavljala še maloštevilno srenjo, ki je bila v veliki meri navezana na tradicijo kulture žarnih grobišč. Vendar je že od samega začetka imela stike tudi z bolj oddaljenimi skupnostmi, kot kažeta stožčasta čelada picenske provenience in jantar domnevno baltiškega izvora. V drugi fazi je nemara postala trgovska postojanka, v kateri je čutiti večjo prisotnost priseljencev iz drugih kulturnih sredin; ti stiki pa so bili verjetno motivirani z razpredanjem trgovske mreže med Sredozemljem, Alpami, Panonijo in severozahodnim Balkanom. V tretji fazi se je magdalenskogorska skupnost opazno povečala in okrepila svojo kulturno identiteto. V četrti fazi se je razvila v proizvodno in distribucijsko središče z dobro vojaško zaščito. V peti fazi pa je dobila vse bolj značaj vojaško-obrambne postojanke na severozahodni meji dolenjskega teritorija.

Hallstatt tradition, but also grave goods of a Celtic character.¹⁶⁰⁹

The events that took place in this phase at Magdalenska gora are not known. The tumuli only reveal individual burials from the Late La Tène Mokronog IIIa phase, which at places damaged earlier graves from the Late Hallstatt period.¹⁶¹⁰ As for the Middle La Tène period, it is not known whether the site was at all populated or if its inhabitants buried their dead in a flat cemetery somewhere in the vicinity. Neither do we know the role the settlement played in the Late La Tène period, nor how it fared against the Roman conquerors. All these questions can only be answered by further field investigation as well as excavation both of the settlement and its surroundings. Thus far, only a Roman-period cemetery was found between Paradišče and Sap at the south-western foot of the hill of Magdalenska gora.¹⁶¹¹

After the phase overview, the main points of the development of the Magdalenska gora community are summarily presented below. In Phase I, the community was small and largely tied to the Urnfield culture tradition, though it also enjoyed contacts with more distant communities from the very beginning, as indicated by the conical helmet of Picene provenance and amber of supposedly Baltic origin. In Phase II, it became a trading post with an increased presence of foreigners from other cultural milieus, whereby these contacts were most likely motivated by the creation of a trading network that covered the Mediterranean, the Alps, Pannonia and the north-western Balkans. The third phase brought about a substantial increase in the number of inhabitants, but also an affirmation of the particular Dolenjska cultural identity. In Phase IV it developed into a production and distribution centre with a good military support, while in the fifth phase it acted more as a military-defence post at the north-western border of the Dolenjska territory.

35, 106b, 116b, 163–164, 170, 226, 251, 285, 345, 362d; Tecco Hvala/Dular/Kocuvan 2004, T. 2A, 10B, T. 19A: 9, 10, 19B, 20A, 21: 12–14, 31B, 38A, 38B, 40A, 59C: 1, 2, T. 149: 11155: 14, 158: 8, 165: 2, 169: 1 in sl. 51.

¹⁶¹¹ Štibernik 2007, 95 ss.

¹⁶⁰⁹ Gabrovec 1966c; Guštin 1977; *id.* 1984; Božič 1987; *id.* 1999.

¹⁶¹⁰ Laščik, *Tum.* 4 and *Gr.* V/5, V/10, V/42; *Preloge, Tum.* I, II or III and *Gr.* VII/7, VII/31, VIII/13, X/55, X/78, 2/e+f, 2/9, 2/10, 2/12, 2/29, 2/41, 2/45, 2/49, 2/71; Hencken 1978, Figs. 35, 106b, 116b, 163–164, 170, 226, 251, 285, 345, 362d; Tecco Hvala/Dular/Kocuvan 2004, T. 2A, 10B, T. 19A: 9, 10, 19B, 20A, 21: 12–14, 31B, 38A, 38B, 40A, 59C: 1, 2, T. 149: 11155: 14, 158: 8, 165: 2, 169: 1 and Abb. 51.

¹⁶¹¹ Štibernik 2007, 95 ff.

6 DRUŽBENI IN KULTURNI PROCESI V STAREJŠI ŽELEZNI DOBI

6 SOCIAL AND CULTURAL PROCESSES IN THE EARLY IRON AGE

Razvoj in družbeno strukturo magdalenskogorske skupnosti si je moč razlagati v povezavi s procesi v širšem geografskem okviru. Kulturna podoba jugovzhodnoalpskega sveta odraža v starejši železni dobi razdrobljenost na več teritorialnih skupnosti, ki so jih razdvajali različni grobni običaji in noša, kar je pravzaprav splošen pojav tistega časa. Na formiranje kulturnih regij in družbenih identitet je domnevno vplivalo več dejavnikov, kot so različne naravne danosti in možnosti za razvoj gospodarstva, kulturni substrat, bližina vplivnih središč, vpetost v menjalno-trgovske tokove, priseljevanje novega prebivalstva, nasilni vpadi idr. V procesu oblikovanja dolenjske halštatske skupnosti, ki ji pripada Magdalenska gora, izstopata dva vidika: eden je nova teritorialna organiziranost, drugi pa družbena diferenciacija z nastankom elite.

TERITORIALNA ORGANIZACIJA

Podrobnejša analiza poselitvene dinamike v dolenjsko-belokranjski regiji je predstavljena v knjigi z naslovom *Jugovzhodna Slovenija v starejši železni dobi: Poselitev – gospodarstvo – družba* in pojasnjuje kontekst, v katerem je nastala in se razvijala magdalenskogorska skupnost.¹⁶¹²

Na prehodu iz bronaste v železno dobo je z opuščanjem starih poselitvenih jeder na tem območju prišlo do spremembe poselitvenega vzorca, zrasla so nova naselja, ki so bila sicer manj številna od prejšnjih, toda po površini v povprečju dvakrat večja, kar priča o procesu *sinoikizma*.¹⁶¹³ Nove aglomeracije so verjetno nastale iz staroselskega prebivalstva in prišlekov iz raznih krajev. V tem smislu si je moč razlagati izbiro različnih lokacij za pokopavanje umrlih, ki se kaže v rastru grobišč okoli novih naselbin; razen tega so iz njihove okolice znana poselitvena jedra iz pozne bronaste dobe, pri nekaterih več, pri drugih manj, kar je morda vplivalo tudi na razlike v njihovi velikosti.¹⁶¹⁴

¹⁶¹² Dular/Tecco Hvala 2007.

¹⁶¹³ *Ibid.*, 136 ss, sl. 77–81.

¹⁶¹⁴ *Ibid.*, 157 ss, sl. 89–93, 96, 100–107.

The development and social structure of the Magdalenska gora community can best be understood in connection with the processes in a wider geographical framework. The community's wider setting is the south-eastern Alps, a region that in the Early Iron Age was culturally divided among several territorial communities with particular costume and funerary rites. The formation of cultural regions and social identities appears to have been influenced by multiple factors, such as various natural conditions and possibilities for economic development, cultural substratum, vicinity of influential centres, place within the trading networks, influx of new inhabitants, violent incursions and others. The formative process of the Dolenjska Hallstatt community is marked by two particularly important aspects, namely a new territorial organisation and a social differentiation with the formation of the elite.

TERRITORIAL ORGANISATION

A detailed analysis of the settlement dynamics in the Dolenjska-Bela krajina region was presented in the book entitled *South-Eastern Slovenia in the Early Iron Age: Settlement – Economy – Society*, which sheds light on the context in which the Magdalenska gora community was formed and later developed.¹⁶¹²

At the transition from the Bronze to the Iron Age, Dolenjska and Bela krajina witnessed a change in the settlement pattern, which is visible in the abandonment of old settlements and springing up of new ones. The latter were fewer in number, but were, on average, twice as large, which indicates a process of *synecism*.¹⁶¹³ The new agglomerations were probably populated by indigenous inhabitants as well as newcomers from other milieus. This is reflected, on the one hand, in the different locations for burying their dead, which is discernible in the layout of the cemeteries around the new agglomerations. On the other hand, new agglomerations were frequently placed somewhere in the vicinity of the abandoned Late Bronze Age settlements.¹⁶¹⁴

¹⁶¹² Dular/Tecco Hvala 2007.

¹⁶¹³ *Ibid.*, 136 ff, Figs. 77–81.

¹⁶¹⁴ *Ibid.*, 157 ff, Figs. 89–93, 96, 100–107.

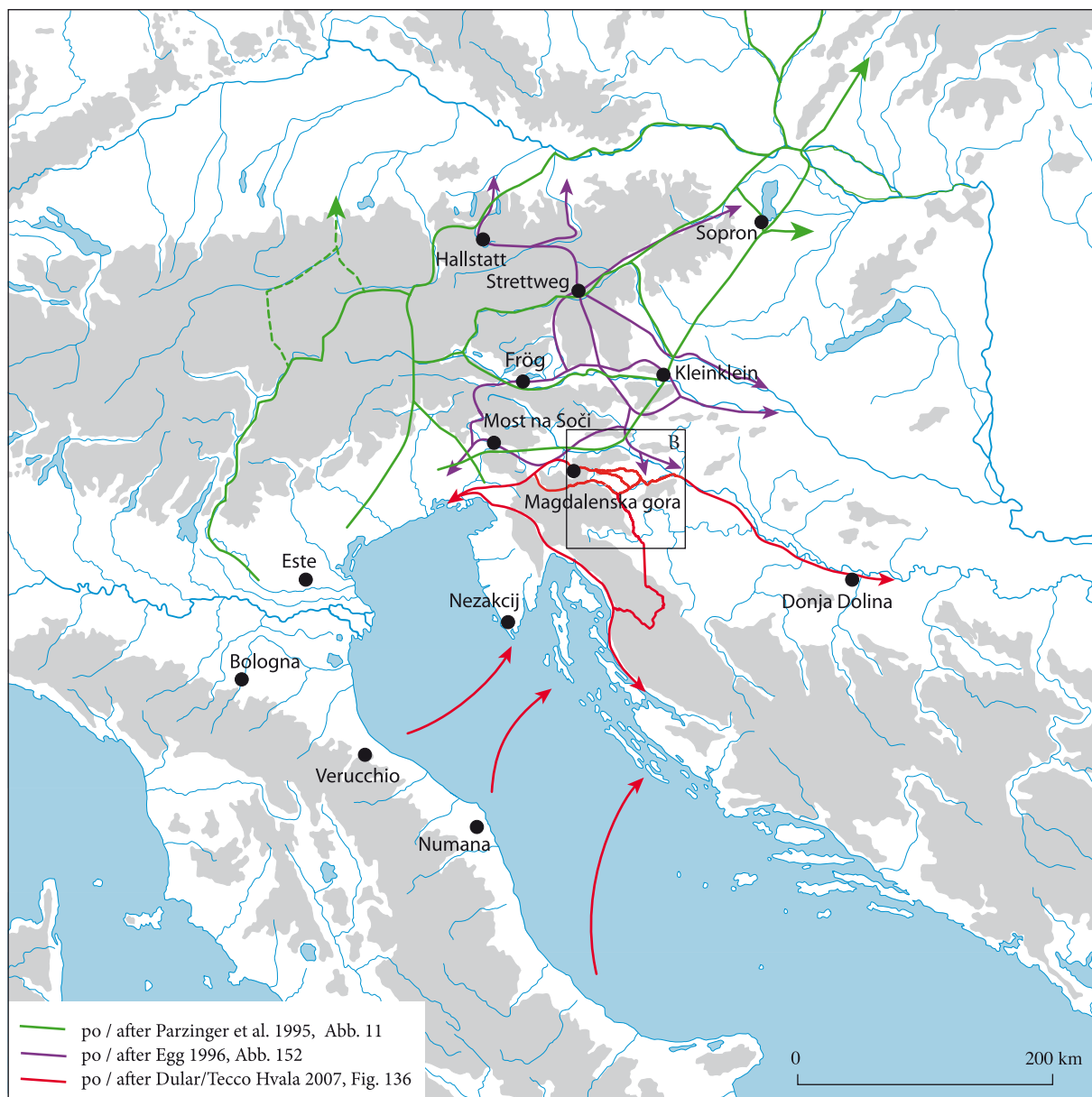

Sl. 132: A – Domnevne komunikacije med severnim Jadranom in vzhodnimi Alpami v času Ha C2/D1.

Fig. 132: A – Hypothetical communication network between the northern Adriatic and the eastern Alps in the periods Ha C2/D1.

Spremembi poselitvenega vzorca je verjetno v znatni meri botroval premik v gospodarski usmeritvi, saj je skorajda 80 % novih naselij zraslo v bližini nahajališč železove rude, iz česar lahko sklepamo, da je postala črna metalurgija pomembna gospodarska panoga.¹⁶¹⁵ Za pridobivanje železovih mineralov na Dolenjskem in v Beli krajini povečini ni bilo potrebno globoko kopati, železovo rudo so lahko pobirali po površju, kar velja tudi za prebivalce Magdalenske gore. Proizvodnja in predelava železa sta hkrati pomenili usvajanje novih tehnoloških postopkov in znanj ter večjo delitev dela, to pa je posledično vplivalo tudi na družbeno organizacijo.

¹⁶¹⁵ *Ibid.*, 212 ss, sl. 123–125.

The change in the settlement pattern appears to have been induced, in large measure, by a shift in the economic base, since almost 80% of new settlements grew up in the vicinity of iron ore deposits. This observation leads us to infer that ferrous metallurgy became an important branch of economic activity.¹⁶¹⁵ The extraction of iron minerals in Dolenjska and Bela krajina for the most part did not necessitate digging deep, since iron ore could be collected on the surface, also by the inhabitants of Magdalenska gora. The production and smelting of iron also meant the adoption of new technological methods and know-how, as well as a greater division

¹⁶¹⁵ *Ibid.*, 212 ff, Figs. 123–125.

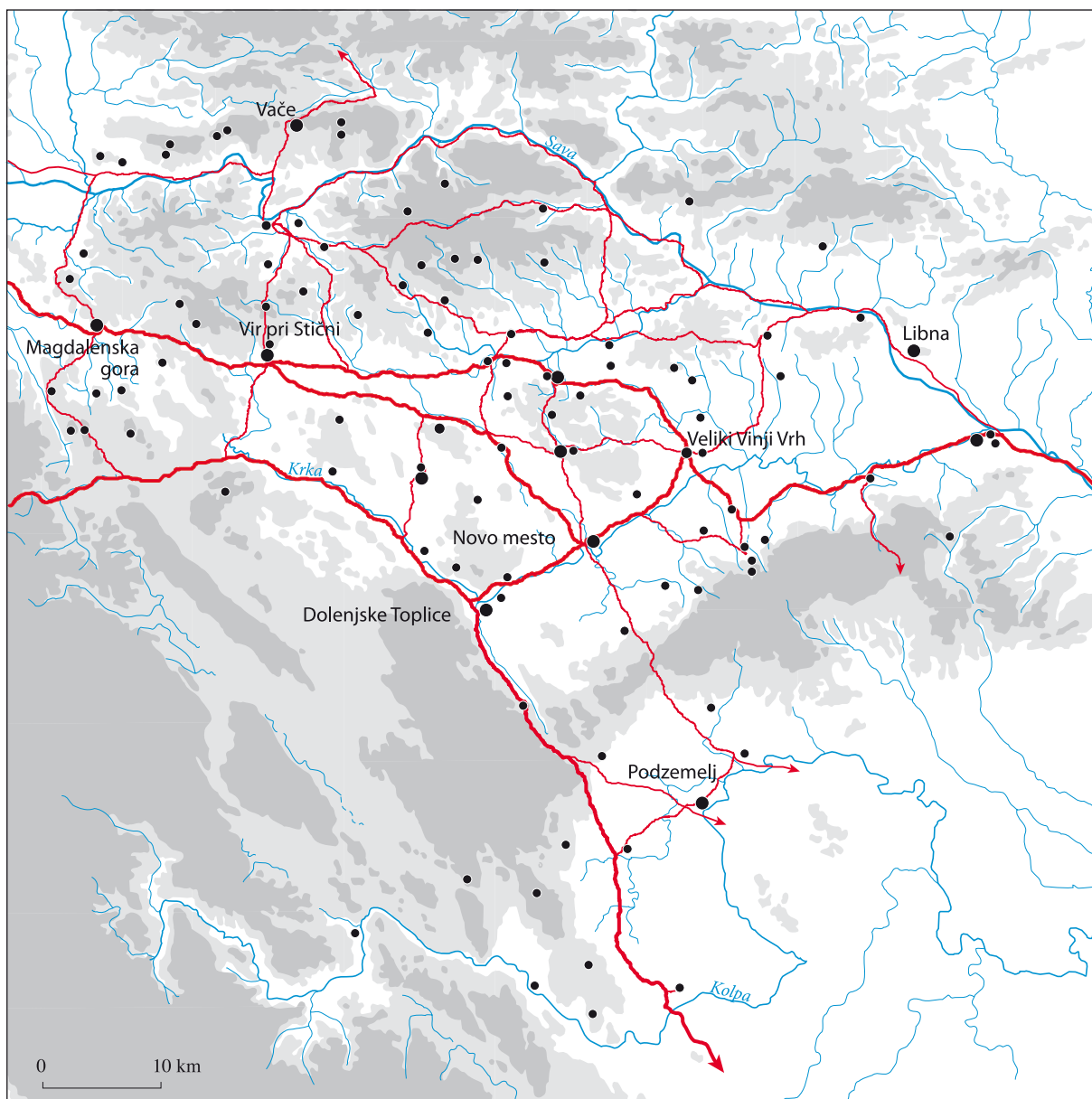

Sl. 132: B – Domnevne komunikacije na Dolenjskem v času stopnje Stična (po Dular/Tecco Hvala 2007, sl. 128).

Fig. 132: B – Hypothetical communication network in Dolenjska in the Stična chronological phase (after Dular/Tecco Hvala 2007, Fig. 128).

Železo je takrat očitno predstavljalo cenjeno dobrino, po kateri je obstajalo povpraševanje, ki je prispevalo k razmahu trgovske menjave.

S tem je bržkone povezan še drug pomemben vidik nove poselitve, tj. nadzor nad komunikacijami. Nova naselja so postavili na dvignjenih legah, tako da so bila v medsebojni vizualni povezavi. Njihov strateški položaj je omogočal nadzorovanje naravnih transverzal med severnim Jadranom, vzhodnimi Alpami, Panonijo in zahodnim Balkanom (sl. 132).¹⁶¹⁶ Nič manj pomembno ni bilo poznavanje teh poti in prehodov za karavanski in rečni promet na dolge razdalje, ki so bile prebivalcem

¹⁶¹⁶ Ibid., 217 ss, sl. 126–131.

of labour, which in turn influenced the organisation of a society. At that time, iron apparently represented a valuable material in considerable demand, which contributed to an upsurge in the exchange of goods.

Another important aspect of the new settlement pattern was territorial control. New settlements grew up on elevations, which offered visual communication. Their strategic position enabled the control over the natural paths and long-distance communications between the northern Adriatic, the eastern Alps, Pannonia and the western Balkans (fig. 132).¹⁶¹⁶ These paths and passes, of great importance for the caravan and river

¹⁶¹⁶ Ibid., 217 ff, Figs. 126–131.

dolenjske skupnosti zagotovo dobro znane. O njihovih stikih z oddaljenimi pokrajinami so ohranjena drobna pričevanja v materialni kulturi, kar kažejo karte razprostranjenosti posamičnih predmetov.

V mreži železnodobnih naselij v gričevnatem svetu Dolenjske in Bele krajine, prepredenim z grebeni, ravniciami in vodotoki, je Magdalenska gora zavzemala strateški položaj na severozahodnih vratih dolenjskega teritorija (sl. 9). Za take skupnosti (*gateway community*) je po teoretskem modelu značilno, da so se razvile ob trgovskih poteh na stičišču različnih kulturnih regij in da je del njihove ekonomije temeljil prav na nadzoru pretoka blaga. Trgovina oz. menjava na dolge razdalje je v tistih časih domnevno potekala "po etapah", od skupnosti do skupnosti, vzdrževala pa se je s pomočjo ritualiziranih oblik partnerskih odnosov z najvidnejšimi predstavniki oz. poglavarji lokalnih skupnosti. Ta ritualni aspekt je vključeval darove oz. poklone (*keimelia*) v zameno za gostoljubnost in varno prečkanje njihovega ozemlja ter v znak spoštovanja dogovorov v družbah brez pisave. Odnosi med različnimi skupnostmi so se morebiti krepili tudi s poročnimi zvezami, s čimer so posamezne družine širile svoj ugled in vpliv onkraj lokalnih meja. Sistem menjave pa bržkone ni bil omejen le na simbolno raven in pasivno sprejemanje luksuznih daril, temveč je vključeval tudi trgovino z uporabnim in potrošnim blagom, kar je stimuliralo domačo proizvodnjo k ustvarjanju presežkov za prodajo in zamenjavo. Razen tega so se morda nekateri ukvarjali s tovorništvo in se podajali na daljše poti v skupinah ali s karavano ter prinašali domov dobrine in ideje iz tujih dežel.¹⁶¹⁷ Obrise takih družbenih pojavov je v starejšem halštatskem obdobju moč zaznati tako v magdalenskogorski kot širši dolenjski skupnosti.¹⁶¹⁸

V začetku mlajšega halštatskega obdobja (Ha D) se je poselitveni vzorec deloma preoblikoval. Gostota naselij se je povečala, v zaledju starohalštatskih središč so zrastle manjši zaselki v bolj odročnih predelih, največ v rudonosnem Posavskem hribovju z nahajališči svinčevih, cinkovih in bakrovih mineralov.¹⁶¹⁹ Korelacija med naselji in bližino rudnih nahajališč je zdaj že 95-odstotna, vizualna pokritost teritorija pa skoraj 50-odstotna.¹⁶²⁰ Ta situacija kaže na kolonizacijo notranjosti in doseljivanje ljudi od drugod, čemur so morda botrovala nemirna dogajanja v vzhodnih pokrajinah, kjer so vpadi konjeniških ljudstev v panonsko-karpatški prostor prizadeli tamkajšnja središča.¹⁶²¹ Štajerske

traffic over long distances, were certainly well known to the inhabitants of Dolenjska and Bela krajina. On the other hand, their contacts with far-off places are well documented in the material heritage, as shown by the distribution maps for individual objects.

Within the network of the Iron Age settlements on the undulating territory of Dolenjska and Bela krajina, covered with hills, flatland and waterways, Magdalenska gora enjoyed a strategic position at the north-western border (fig. 9). It could be said that, in view of the above, Magdalenska gora played the role of a so-called *gateway community*. According to the theoretic model, these communities characteristically developed along trade routes at the contact zone of different cultural regions, whereby a part of their economy was based on the control of traffic. Long-distance trade presumably took place "in stages", from one community to the next, maintained through ritualized forms of partnership between chief representatives or chieftains of the local communities. This ritual aspect involved gifts or *keimelia* in exchange for hospitality and safe crossing of territory, but also as a sign of respect of an agreement in preliterate societies. Relationships between communities may also have been strengthened through marriage, practiced by individual families to solidify their partnership and expand their influence beyond one's own territorial border. The system of exchange was probably not limited to the symbolic level and to a passive reception of valuable gifts, but also involved trading with consumer goods. This stimulated the local production to generate surplus to be sold or exchanged for other goods. Apart from this, some members may have been engaged in long-distance transport, in groups or caravans, and were thus bringing home goods and ideas from foreign lands.¹⁶¹⁷ These social phenomena can, in outlines, also be discerned in the Early Hallstatt period in the Magdalenska gora community and wider in Dolenjska.¹⁶¹⁸

At the beginning of the Late Hallstatt period (Ha D), the settlement pattern in Dolenjska partially changed. Settlement density increased through colonization of the hinterland of the old, Early Hallstatt centres. Most of the new habitation nuclei were documented in the region of the Posavsko hribovje, rich in lead, zinc and copper deposits.¹⁶¹⁹ The correlation between settlements and vicinity of ore deposits in this period rose to 95%, while the visual control of the territory to almost 50%.¹⁶²⁰ Such a situation indicates immigration of people from elsewhere, which may have been brought about by the

¹⁶¹⁷ Fisher 1973; Earle/Ericson (ur.) 1977; Wells 1980; Champion/Megaw (ur.) 1985; Palavestra 1993, 172 ss; Renfrew/Shennan (ur.) 2009; Krausse (ur.) 2010.

¹⁶¹⁸ Teržan 1995b, 95 ss; ead. 2008, 294 ss; Dular/Tecco Hvala 2007, 229 ss.

¹⁶¹⁹ Dular/Tecco Hvala 2007, 50 ss, 143 ss, sl. 18, 19, 82, 84, 85; Draksler 2007.

¹⁶²⁰ Dular/Tecco Hvala 2007, 213 ss, sl. 123, 131.

¹⁶²¹ Teržan 1990a, 204 s, sl. 55; ead. 1998, 526 ss; Gabrovec 1999, 186; Dular J. 2008, 427; Teržan 2008, 308, 319.

¹⁶¹⁷ Fisher 1973; Earle/Ericson (eds.) 1977; Wells 1980; Champion/Megaw (eds.) 1985; Palavestra 1993, 172 ff; Renfrew/Shennan (eds.) 2009; Krausse (ed.) 2010.

¹⁶¹⁸ Teržan 1995b, 95 ff; ead. 2008, 294 ff; Dular/Tecco Hvala 2007, 229 ff.

¹⁶¹⁹ Dular/Tecco Hvala 2007, 50 ff, 143 ff, Figs. 18, 19, 82, 84, 85; Draksler 2007.

¹⁶²⁰ Dular/Tecco Hvala 2007, 213 ff, Figs. 123, 131.

naselbine so takrat domala opustele, medtem ko je v dolenski regiji opazno obnavljanje obzidij okoli starih poselitvenih jeder, na drugi strani pa zamiranje nekaterih krajev v spodnjem toku Krke in ob Kolpi. Del prebivalstva se je od tam morebiti preselil v osrednjo Dolenjsko ali v severozahodna središča, ki so se prav takrat okrepila (Stična, Magdalenska gora, Vače).¹⁶²² Prišleki so predstavljali novo delovno silo, ki se je nemara udejstvovala v rudarsko-metalurški dejavnosti. V Posavskem revirju na severovzhodu pokrajine, kjer so naravni pogoji za poljedelstvo slabši, so se domnevno ukvarjali s pridobivanjem barvnih kovin, za kar je bilo potrebno rudariti. Prav mogoče je, da so s kovino oskrbovali večja lokalna središča, kjer je potekala nadaljnja predelava, kamor so prihajali potujoči mojstri torevtike in kjer je potekala menjava dobrin, ki je po konsolidaciji razmer znova zaživela.

Za take domneve govori vrsta kazalnikov. V mnogih naseljih je bila najdena žlindra, ponekod tudi železni ingoti, talilne peči in pripomočki za to dejavnost.¹⁶²³ V primerjavi s starejšim halštatskim obdobjem je količina izdelkov iz brona, železa, stekla pa tudi jantarja precej narasla; samo fibul je po grobi oceni za četrtno več, na Magdalenski gori pa še dosti več, pomnožila se je tudi količina železnega orožja¹⁶²⁴ in prestižnih predmetov, denimo izdelkov situlske umetnosti. Sled za potujočimi rokodelci – torevti – se morda skriva v žanrskih prvinah, v enotnih stilskih potezah, kompoziciji in dekorativnih elementih. Obris hierarhije med naselji pa so razpoznavni v različnih velikostih in naravnem potencialu njihovega zaledja, v številu pripadajočih gomil, v bogastvu grobnih pridatkov, importih itd.¹⁶²⁵ Večja središča so imela boljše naravne pogoje za samooskrbo, okoli njih je več gomilnih grobišč, v katerih so bili odkriti tudi najprestižnejši grobovi. Na osnovi tega domnevamo, da so predstavljala gospodarsko in politično moč, ki je temeljila na bolj razvejanih dejavnostih, med katerimi sta bili zagotovo pomembni distribucija dobrin in blagovna menjava, ki je morebiti že vključevala nekakšne predmonetarne oblike plačilnih sredstev (ražnje ali *oboloi*, morda tudi *aes rude*),¹⁶²⁶ predvsem pa je prispevala k formiranju elite. Manjša naselja, zaselki in kmetije so svoje proizvode in presežke domnevno prinašali v lokalna središča, kjer so jih med drugim zamenjevali za bolj luksuzne predmete. Tako na primer v osamljenih gomilah, raztresenih po dolenskih gričih, zasledimo

¹⁶²² Dular/Tecco Hvala 2007, 70 ss, 247 ss, sl. 40, 41, 47–49, 143.

¹⁶²³ *Ibid.*, 215 ss, sl. 125.

¹⁶²⁴ Glej tu poglavje 4.7 o fibulah in 4.1 o orožju.

¹⁶²⁵ Dular/Tecco Hvala 2007, 191 ss, sl. 110–113.

¹⁶²⁶ O predmonetarnih plačilnih sredstvih glej Teržan 2004a; ead. 2008, 294 ss; glej še tu poglavje 4.5.2 o ražnjih. Kot *aes rude* bi bilo možno interpretirati kose brona, ki jih z Magdalenske gore hrani NMS med najdbami brez znanih grobnih celot: Tecco Hvala/Dular/Kocuvan 2004, T. 161: 23,24; za primerjavo glej Cattani 1987, 204 ss.

disturbances in the regions to the east, where the centres were hard hit by the incursions of horse-riding peoples into the Pannonian-Carpathian region.¹⁶²¹ At that time, settlements in Styria / Štajerska were abandoned. In Dolenjska, the old centres saw their defence walls being restored, while several settlements in the lower reaches of the Krka and along the Kolpa fell into decline. Part of their inhabitants may have migrated to central Dolenjska or its north-western centres, which witnessed growth in that period (Stična, Magdalenska gora, Vače).¹⁶²² The new-comers represented new workforce, which may have been employed in mining and metallurgy. For the Posavje mining district, in the north-east of Dolenjska, where the natural conditions for arable farming are poor, the economic activity was supposedly mainly orientated towards extraction of non-ferrous metals, which involved mining. This region potentially supplied the raw material needed for further metalworking to the large local centres, where itinerant masters of torevtics came to practice their craft and where the exchange of goods took place; the latter now again flourishing after the situation became stabilized.

The suppositions above are supported by a number of indicators. Numerous settlements revealed slag; some even iron ingots, smelting furnaces and metalworking implements.¹⁶²³ Furthermore, a comparison with the Early Hallstatt period showed that the quantity of products of bronze, iron, glass and amber increased substantially. Fibulae, for example, are more numerous represented by roughly a quarter in Dolenjska and even more at Magdalenska gora. Also on the increase was the quantity of iron weapons¹⁶²⁴ and items of prestige, such as products of the situla art. In connection with the latter, the activity of the itinerant craftsmen-masters of torevtics may be traced through genre elements, uniform stylistic features, composition and decorative elements. As for the settlements, the outlines of their hierarchy can be discerned from the differences in their size, natural potential of their hinterland, number of associated tumuli, wealth of grave goods, imports and so forth.¹⁶²⁵ Large centres had better natural conditions for self-sufficiency; they were surrounded by more numerous tumulus cemeteries that, moreover, yielded the most prestigious graves. Based on these observations, such a centre would have represented an economic and political force based on a range of activities. The latter most certainly included the distribution and exchange of goods, which may have involved premonetary means of payment (for example spits or *oboloi*, possibly also *aes*

¹⁶²¹ Teržan 1990a, 204 f, Fig. 55; ead. 1998, 526 ff; Gabrovec 1999, 186; Dular J. 2008, 427; Teržan 2008, 308, 319.

¹⁶²² Dular/Tecco Hvala 2007, 70 ff, 247 ff, Figs. 40, 41, 47–49, 143.

¹⁶²³ *Ibid.*, 215 ff, Fig. 125.

¹⁶²⁴ See Chapter 4.7 on fibulae and 4.1 on weapons.

¹⁶²⁵ Dular/Tecco Hvala 2007, 191 ff, Figs. 110–113.

jantarne in steklene ogrlice, bronasto posodo, polže kavre (*Cyprea moneta*) ipd., ki so se tam znašli bržkone po tej poti.¹⁶²⁷ Na drugi strani sta razvejana dejavnost in menjava dobrin privedli do večje soodvisnosti in tesnejše povezave med naselji na tem teritoriju, kar se odraža v enotnem grobnem ritualu in prvinah noše, ki predstavljajo simbolni izraz kulturne identitete in družbene povezanosti.

V začetku 5. st. pr. n. št. je v dolenskem prostoru čutiti daljni odmev procesov in dogajanj v Padski nižini, ki jih je spodbudil t. i. drugi val etruščanske kolonizacije.¹⁶²⁸ Felsina (Bologna) se je takrat povezala z etruščansko-padskimi mesti (Marzabotto, Mantova, Adria, Spina idr.) v enovit gospodarsko-politični sistem, ki je obvladoval blagovnomerjalne tokove med matično tirensko Etrurijo in alpskim svetom ter prek jadranske povezave z Grčijo. To je bil čas velikega gospodarskega razcveta, živahnega trgovanja, urbanega razvoja in razvoja novih družbenopolitičnih tvorb. V emporijih Adria in Spina, s strateško lego ob izlivu reke Pad v Jadransko morje, je tedaj živelo mešano prebivalstvo – poleg lokalnega tudi Etruščani in grški kolonisti, ki so ljudstvom v zaledju posredovali grške proizvode in jim približali grški duhovni svet ter kulturne vrednote. V jadranskem prostoru so se razširili kult herojev pa trojanski mit in legende o Antenorju, Diomedu, Faetontu, Dedalu, Herakleju ipd.¹⁶²⁹ Odsev grško-etruske ideologije je v jugovzhodnih Alpah moč razbrati v upodabljanju umetnosti in v grobnem kultu, ki je vključeval servise posodja za banket oz. simpozij.¹⁶³⁰

V 4. st. pr. n. št. je dozdevno nastopila kriza, ki je zajela vse južno obrobje Alp in Padsko nižino, kjer je invazija keltskih plemen povzročila razpad politično-ekonomske organizacije etruščanskih mest in pretrgala obstoječo trgovsko mrežo;¹⁶³¹ v pomorski promet

rude),¹⁶²⁶ and certainly contributed to the formation of an elite. Smaller settlements, hamlets and farmsteads may have been bringing their products and surplus to the local centres, where they exchanged them for more prestigious items. This may be the explanation for the amber and glass beads, bronze vessels, cowrie shells (*Cyprea moneta*) and other similar objects found in isolated tumuli strewn across the hills of Dolenska.¹⁶²⁷ On the other hand, varied activities and exchange of goods led to an increased interdependence and interconnection among the settlements on the territory of Dolenska, which is reflected in the uniform funerary ritual and elements of costume, which represent a symbolic expression of cultural identity and social cohesion.

At the beginning of the fifth century BC, Dolenska witnessed a distant echo of the processes and events in the Po Plain, induced by the so-called second wave of Etruscan colonization.¹⁶²⁸ Felsina, modern Bologna, associated itself with the new Etruscan cities in the Po Plain (Marzabotto, Mantova, Adria, Spina and others) into an integrated economic and political system that controlled the routes of goods exchange between the original Etruria along the Tyrrhenian Sea and the Alpine world, as well as, via the Adriatic, with Greece. This was a time of flourishing economy, burgeoning trade, urban development and formation of new socio-political entities. Adria and Spina – the two emporia of the time with a strategic position at the mouth of the River Po – were inhabited by a mixed population of locals as well as Etruscans and Greek colonists. The latter supplied Greek products and familiarized the people in the hinterland with the Greek imagery and cultural values. The Adriatic area witnessed a spread of hero cults as well as the Trojan myth and legends of Antenor, Diomedes, Phaeton, Daedalus, Heracles and others.¹⁶²⁹ This Greco-Etruscan ideology is also per-

¹⁶²⁷ Posamične gomile so registrirane na najdiščih npr. *Zadnja hosta pri Podturnu, Ostrvec pri Rihpovcu, Zelkova hosta pri Rihpovcu, Martinov britof v Zagorici pri Čatežu, Dele pri Kladju nad Blanco, Močile pri Zg. Mladetičih, Lopanec pri Kaplji vasi, Slančji vrh* idr.: Dular J. 2003, sl. 112, 114, 115, 118, 119, 145, 146, T. 22: 11-14, 23-25, 26: 1-6, 30-35, 37-40, 50, 51, 52: 1-4, 81-86, 87: 1-4; glej še Dular/Tecco Hvala 2007, 146 ss, sl. 83, 85.

¹⁶²⁸ Kimmig 1974, 54 ss, Abb. 5, 6, 9; Braccesi 1979, 135 ss; Bonghi Jovino 1992 (Bildband), 35, Fig. 1; Fogolari 1996, 21; Malnati 1996, 6 ss; Càssola Guida 1996, 317 s; Bonamici 2000, 80 ss; Sassatelli 2000; Capuis 2000, ter razne razprave v: De Marinis (ur.) 1987; Aigner-Foresti L. (ur.) 1992; *La protostoria tra Sile e Tagliamento* 1996.

¹⁶²⁹ Braccesi 1979; id. 1984; id. 2003; Grilli 1991; Mastrocinque 1987; id. 1991; Katičić 1989; Teržan 1990a, 62, op. 185; Kirigin/Čače 1998; Torelli 2000; Manichetti 2000; Capuis/Ruta Serafini 2002; Cerchiai 2000; Šašel Kos 1999, 13 ss; ead. 2005, 115 ss; ead. 2006; D'Ercole 2006.

¹⁶³⁰ Teržan 1980; ead. 1997; ead. 2008, 321.

¹⁶³¹ Frey 1987, 9 ss; Fogolari 1996, 22 s; Malnati 1996, 8; Càssola Guida 1996, 319; ead. 2001, 349 ss; Vitri 2001, 33; Ruta Serafini 2001, 201 s; Marzatico 2001, 232 s; De Marinis

¹⁶²⁶ For premonetary means of payment see Teržan 2004a; ead. 2008, 294 ff; and Chapter 4.5.2 on spits. Kept in the NMS among the finds from Magdalenska gora without preserved grave groups are several amorphous pieces of bronze, which could be interpreted as *aes rude* (Hvala/Dular/Kocuvan 2004, T. 161: 23,24); cf. Cattani 1987, 204 ff.

¹⁶²⁷ Isolated tumuli have been registered on numerous sites such as at *Zadnja hosta near Podturn, Ostrvec near Rihpovec, Zelkova hosta near Rihpovec, Martinov britof near Zagorica pri Čatežu, Dele near Kladje nad Blanco, Močile near Zg. Mladetiče, Lopanec near Kaplja vas, Slančji vrh* and others: Dular J. 2003, Abb. 112, 114, 115, 118, 119, 145, 146, T. 22: 11-14, 23-25, 26: 1-6, 30-35, 37-40, 50, 51, 52: 1-4, 81-86, 87: 1-4; see also Dular/Tecco Hvala 2007, 146 ff, Figs. 83, 85.

¹⁶²⁸ Kimmig 1974, 54 ff, Abb. 5, 6, 9; Braccesi 1979, 135 ff; Bonghi Jovino 1992 (Bildband), 35, Fig. 1; Fogolari 1996, 21; Malnati 1996, 6 ff; Càssola Guida 1996, 317 f; Bonamici 2000, 80 ff; Sassatelli 2000; Capuis 2000, and various treatises in: De Marinis (ed.) 1987; Aigner-Foresti L. (ed.) 1992; *La protostoria tra Sile e Tagliamento* 1996.

¹⁶²⁹ Braccesi 1979; id. 1984; id. 2003; Grilli 1991; Mastrocinque 1987; id. 1991; Katičić 1989; Teržan 1990a, 62, n.

po Jadranu pa se je vmešal Dionizij I. Sirakuški.¹⁶³² Spremenjene razmere so v tem času občutne tudi na Dolenjskem, kamor so prek južnega obrobja Alp in s severa prek alpskih dolin prodrli vplivi zgodnjelatske kulture, ki so se odrazili v posameznih prvinah predvsem moških oprav. Na drugi strani pa krizo naznanja večje oboroževanje, deloma tudi sprememba tehnike bojevanja z uporabo mečev, bojnih nožev in kopij; pridatki v grobovih so čedalje skromnejši in manj kvalitetni, kar govori o pojemanju gospodarske moči in zatonu halštatske kulture.

Kakor je razvidno iz analiz materialne zapuščine magdalenskogorske skupnosti, se je ta kraj v mlajšem halštatskem obdobju povzpел med vodilna proizvodna in distribucijska središča v jugovzhodnih Alpah. Morda se je takrat magdalenskogorska skupnost polastila tudi rudnika svinca, ki leži na pol poti do severneje ležečega naselja na Molniku. V kakšnih odnosih je bila z molniško srenjo, je težko oceniti, ker najdbe iz tamkajšnjih gomil še niso v celoti objavljene in ovrednotene. Po drugi strani je videti, da je po bogastvu in prestižnih predmetih prekosila južno sosedo Stično, ki ji je dotlej v marsičem pripadal primat.

Vlogo Stične v dolenski skupnosti je nazadnje osvetlila in ovrednotila Teržanova; njena razlaga razmerij med halštatskimi centri na Dolenjskem pa se nekoliko razlikuje od tiste, ki sva jo z Dularjem podala v študiji o poselitvi te pokrajine, v kateri sva na podlagi velikosti naselja, grobišč in po prestižnih grobovih ugotavljala, da nobeno od lokalnih središč ne izstopa do tolikšne mere, da bi mu lahko pripisali vodilni značaj.¹⁶³³ Teržanova to tezo relativizira in v organizaciji oz. obvladovanju tega prostora (enako kot v strukturiranosti rodovin in klanov) vidi dualističen princip z dvema regionalnima centroma, ki sta bila domnevno v ekvilibrističnem razmerju, druga naselja pa v podrejenem položaju. Po njenem je v formativni fazi vloga regionalnega središča na vzhodnem delu Dolenjske pripadala Velikemu Vinjemu vrhu (Šmarjeti), ki so mu bili podrejeni centri, kot so Brezje, Novo mesto, Velike Malence in Libna, medtem ko je v zahodnem in osrednjem delu Dolenjske to vlogo imela Stična, pod njeno nadvlado pa naj bi bila Magdalenska gora in Molnik. V naslednji stopnji naj bi Stična ohranila svoj vodilni položaj, medtem ko ga je Šmarjeta izgubila in je prvenstvo v vzhodni Dolenjski prevzelo Novo mesto. V mlajšem halštatskem obdobju naj bi se izkristaliziralo dvoje centrov vojaške in politične moči na severozahodu pokrajine – Stična in Magdalenska gora, pri čemer naj bi Stična obdržala vodilno vlogo. Teržanova svojo razlago utemeljuje z vojaškim poten-

ceptible in the area of the south-eastern Alps, in artistic products and funerary ritual that came to include sets of banqueting vessels.¹⁶³⁰

The fourth century apparently brought on a period of crisis that hit the southern fringes of the Alps and the Po Plain, where an invasion of Celtic tribes caused a disintegration of the political-economic alliance of Etruscan cities and their trade network.¹⁶³¹ The maritime traffic along the Adriatic, on the other hand, suffered encroachment on the part of Dionysius I of Syracuse.¹⁶³² The changed circumstances were also felt in Dolenjska and are noticeable in the influences of the Early La Tène culture that arrived here from the west, via the southern fringes of the Alps, and from the north, via the Alpine valleys. These influences are visible in certain elements, primarily of the male costume. A time of crisis is also discernible in the increased armament and partly also in the change of battle tactics that involved the use of swords, battle knives and lances. Moreover, grave goods become less numerous and of poorer quality, which indicates waning economic strength and a decline of the Hallstatt culture.

The analyses of the material remains of the Magdalenska gora community show that the settlement in the Late Hallstatt period rose to one of the leading production and distribution centres of the south-eastern Alps. It may even have seized the lead mine located halfway between Magdalenska gora and Molnik to the north. The relationship between the two settlements is difficult to assess, since the finds from the tumuli around Molnik have not yet been integrally published. On the other hand, analyses have shown that Magdalenska gora surpassed, in wealth and prestige, their southern neighbour at Stična, which up to that time held primacy in many respects.

The role that Stična played within the Dolenjska community was last assessed by Teržan. Her explanation of the relationships between the Hallstatt centres in Dolenjska, however, differs somewhat from that proposed by Dular and Tecco Hvala in the 2007 study. Based on the settlement and cemetery size as well as prestige graves, we established that none of the local centres stood apart to the point of being ascribed the leading role.¹⁶³³ Teržan attempted to relativize this hypothesis and saw, in the social organization and territorial control, a dualistic principle, with two regional centres in supposed equilibrium and several subordinate settlements. She ascribed

185; Kirigin/Čače 1998; Torelli 2000; Manichetti 2000; Capuis/Ruta Serafini 2002; Cerchiai 2000; Šašel Kos 1999, 13 ff; ead. 2005, 115 ff; ead. 2006; D'Ercole 2006.

¹⁶³⁰ Teržan 1980; ead. 1997; ead. 2008, 321.

¹⁶³¹ Frey 1987, 9 ff; Fogolari 1996, 22 f; Malnati 1996, 8; Càssola Guida 1996, 319; ead. 2001, 349 ff; Vitri 2001, 33; Ruta Serafini 2001, 201 f; Marzatico 2001, 232 f; De Marinis 2001, 355 ff; etc. In this period, a considerable share of graves without grave goods has been documented in cemeteries such as at *Bologna* and *Casalecchio di Reno*: Ortalli 1995, 205.

¹⁶³² Braccesi 2003, 10 ff; Šašel Kos 2005, 127 ff, 545.

¹⁶³³ Dular/Tecco Hvala 2007, 191 ff.

2001, 355 ss; idr. Znatno delež skeletnih grobov brez pridatkov iz tega časa je znan npr. v grobiščih v *Bologna* in *Casalecchio di Reno*: Ortalli 1995, 205.

¹⁶³² Braccesi 2003, 10 ss; Šašel Kos 2005, 127 ss, 545.

¹⁶³³ Dular/Tecco Hvala 2007, 191 ss.

cialom (predvsem s prestižnim obrambnim orožjem, kot so čelade, oklepi in ščiti, ter s pokopi konjev) in pa s prostorsko razporeditvijo moči na regionalni ravni. In zaključni, da je dolenska skupina od svojega nastanka dalje predstavljala kohezivno, teritorialno organizirano družbo, v kateri je Stični kljub spremembam in menjavam partnerstva uspelo vseskozi držati vodilni položaj, kar posebej izpostavlja njen izjemen, prvenstven pomen.¹⁶³⁴

Ali res? Da je za zagotavljanje dominacije vojaška sila odločilna, ni dvoma, vprašanje pa je, ali je obrambno orožje (čelade, oklepi in ščiti) zadosten oz. dovolj reprezentativen kriterij za oceno vojaškega potenciala. Teržanova je v eni od svojih zgodnejših razprav o halštatski družbeni strukturi (1985) pokazala, da je bila večina moških v starejšem halštatskem obdobju na Dolenjskem neoborožena, najmanj grobov z orožjem pa je znanih prav iz Stične.¹⁶³⁵ Iz tega bi lahko razbrali, da je orožje tedaj pomenilo predvsem izkazovanje prestiža oz. materialnega in simbolnega "kapitala"¹⁶³⁶ bolj kot pa dejansko vojaško potenco. Če med kriterije uvrstimo še napadalno orožje (npr. meče,¹⁶³⁷ bodala,¹⁶³⁸ sekire¹⁶³⁹), potem dominacija dveh središč ni več tako očitna. Še manj je jasna, če vključimo kake druge kazalce prestiža, denimo bronasto in estensko-svetolucijsko posodje¹⁶⁴⁰ (ne le apulske kraterje) ali žezla kot poglavarstvo oz. poveljniško insignijo.¹⁶⁴¹ Na drugi strani lahko med pokazatelje materialnega blagostanja posamezne srenje štejejo tudi fibule (kot kronološko najbolj občutljivo prvino)¹⁶⁴² ter jantar¹⁶⁴³ ipd. Po večini teh kriterijev pa Magdalenska gora v mlajšem halštatskem obdobju daleč prekaša Stično, zato teza, da je Stična tudi v tem času uspela obdržati primat, ni prepričljiva. Prav tako si je s prostorskega zornega kota težko predstavljati, da bi Dolenjski vladala dva centra na skrajnem severozahodu pokrajine. Ob tem se zastavlja vprašanje, kateri teritorij bi po dualističnem principu delitve obvladovala precej močnejša Magdalenska gora.

¹⁶³⁴ Teržan 2008, 310 ss.

¹⁶³⁵ Ead. 1985, 95 s, sl. 16, 17.

¹⁶³⁶ Pojma simbolni in materialni kapital povzeman po Bourdieuju (2002).

¹⁶³⁷ Guštin 1974a, 75 ss; Škoberne 1999, sl. 68; Teržan 2008, 284 s, 295.

¹⁶³⁸ Frey 1980a, 333 ss.

¹⁶³⁹ Glej tu poglavje 4.1 o orožju, sl. 47.

¹⁶⁴⁰ Glej tu poglavje 3.2.1 o bronastem posodju in tujih keramičnih formah. Ob tem velja prav tako izpostaviti, da je z Magdalenske gore znanih največ izdelkov situlske umetnosti: Teržan 2008, 322.

¹⁶⁴¹ Glej tu poglavje o 4.5.1 o žezlih.

¹⁶⁴² Dular/Tecco Hvala 2007, 247 ss, sl. 142–144. Glej še tu poglavje 4.7 o fibulah, sl. 83: B, 90, 98.

¹⁶⁴³ Glej tu poglavje 4.8.2 o jantaru, sl. 105.

the leading role during the formative phase to Veliki Vinji vrh (Šmarjeta) in the east, with subordinate settlements at Brezje, Novo mesto, Velike Malence and Libna, while the western and central Dolenjska was dominated by Stična, with subordinate settlements at Magdalenska gora and Molnik. In the following phase, Stična supposedly retained its position, while Šmarjeta lost it in favour of Novo mesto. During the Late Hallstatt period, two centres of military and political power formed in the northwest of Dolenjska, namely Stična and Magdalenska gora, whereby Stična retained its leading role. Teržan founded this observation on military potential, primarily on prestige armour (helmets, cuirasses and shields) and burials of horses, as well as on the spatial distribution of power on a regional level. Teržan concluded her study with the observation that the Dolenjska group represented a cohesive and territorially organized society, in which Stična played the leading role in spite of all the alterations and changes of partnership, which further reinforced the primary importance of the centre.¹⁶³⁴

The correctness of her conclusions, however, is not convincing. There is no doubt of the military force being a key factor in asserting dominance; what is questionable, however, is whether the rare pieces of armour (helmets, cuirasses and shields) can serve as an adequate or representative enough criterion for assessing military potential. In her 1985 study on the social structure, Teržan showed that, in the Early Hallstatt period, most men from Dolenjska were unarmed, with the least graves with weapons actually documented at Stična.¹⁶³⁵ This would indicate that weapons in that time served mainly as an expression of prestige or of material and symbolic "capital"¹⁶³⁶ rather than actual military potential. If, moreover, the criteria were to include arms such as swords,¹⁶³⁷ daggers¹⁶³⁸ and axes,¹⁶³⁹ the dominance of two centres becomes less obvious. It becomes even less obvious if considering other indicators of prestige, for example bronze and Este-Sveta Lucija type of vessels¹⁶⁴⁰ (and not only Apulian *krater*), as well as maces as commanders' insignia.¹⁶⁴¹ Besides, the material prosperity of a community could also be assessed by other indicators, such as fibulae¹⁶⁴² (as the chronologically most sensitive

¹⁶³⁴ Teržan 2008, 310 ff.

¹⁶³⁵ Ead. 1985, 95 f, Abb. 16, 17.

¹⁶³⁶ I refer to Bourdieu's conception of material and symbolic capital (Bourdieu 2002 (1980)).

¹⁶³⁷ Guštin 1974a, 75 ff; Škoberne 1999, Fig. 68; Teržan 2008, 284 f, 295.

¹⁶³⁸ Frey 1980a, 333 ff.

¹⁶³⁹ See Chapter 4.1 on weapons, fig. 47.

¹⁶⁴⁰ See Chapter 3.2.1 on bronze vessels and foreign ceramic forms. It is also worth mentioning that in all Dolenjska, most masterpieces of the situla art were unearthed at Magdalenska gora: Teržan 2008, 322.

¹⁶⁴¹ See Chapter 4.5.1 on maces.

¹⁶⁴² Dular/Tecco Hvala 2007, 247 ff, Figs. 142–144. See Chapter 4.7 on fibulae, figs. 83: B, 90, 98.

DRUŽBENA STRUKTURA IN DIFERENCIACIJA

Splošno je znano, da začetek železne dobe na Dolenjskem med drugim obeležuje spremenjen grobni ritual, v katerem se je uveljavil nov program. Sežiganje umrlih je zamenjala inhumacija, z opuščanjem planih grobišč in s pokopavanjem v gomile se je spremenil raster grobišč, ki odraža nov prostorski koncept in stremjenje k monumentalnosti. V gomilah, razmeščenih v ločenih vrstah, gručah ali posamično ob vpadnicah v naselja, je običajno pokopanih več pokolenj moških, žensk in otrok skupaj, pokopi pa so razporejeni v koncentričnih krogih okoli osrednjega groba ali okoli prazne sredine. Razpored grobov in zgradbo gomil poznamo predvsem po zaslugi modernih raziskovanj v Stični in Novem mestu (*sl.* 42, 43); stiške gomile so bile deležne tudi poglobljenih analiz, pokopi v njih pa osvetljeni z različnih vidikov. Razlage, ki sta jih v tej zvezi podala Gabrovec in Teržanova, so dobro vodilo za razumevanje strukture gomil drugod po Dolenjski in v Beli krajini, ki so bile prekopane v prejšnjih časih, ko postopki terenskih raziskav še niso bili tako razviti, kar velja tudi za Magdalensko goro. Na podlagi podatkov o mestu pokopa, grobnih obeležjih in strukturi grobnih pridakov jih interpretirata kot ogledalo družinsko-rodovne skupnosti, v kateri se je izoblikoval vodilni sloj oz. rodovna aristokracija.¹⁶⁴⁴

O STRUKTURI GROBIŠČA

Analize v predhodnih poglavjih te knjige so pokazale, da so prebivalci Magdalenske gore že od samega začetka svoje umrle pokopavali na treh ločenih lokacijah, da geneza grobišča ni sledila preprostemu konceptu horizontalne stratigrafije, da je bil vse tja do mlajšega halštatskega obdobja v uporabi dvojni ritual pokopavanja, iz česar bi lahko zaključili, da je bila ta skupnost segmentarno zasnovana, razdeljena na več družbenih enot, v katerih bi lahko videli družine, ki so izvirale iz raznih krajev.

V samo zgradbo magdalenskogorskih gomil nimamo tako detajlnega vpogleda, kot ga ponujata gomili 48 in 5 iz Stične, ki ju je preučila Teržanova in pokazala, da je šlo za bipolarno delitev, da je bilo mesto pokopa odvisno od raznih dejavnikov in ni sledilo zgolj paradigmi preprostega sosledja v krožnem poteku. Lega pokojnikov v grobovih na jugovzhodnem delu gomile je sledila smeri urnega kazalca, v severozahodnem delu pa nasprotni smeri (*sl.* 42), kar deli gomilo na enaki polovici in kaže na dualistični princip v organiziranosti. Razen tega je zanimiva ugotovitev, da se moški pokopi grupirajo na

artefacts), as well as amber¹⁶⁴³ and other goods. The majority of these indicators suggest that Magdalenska gora far surpassed Stična in the Late Hallstatt period and speak against the hypothesis of Stična retaining its primacy. It is moreover difficult to imagine the territory of Dolenjska being governed by two centres both located in its north-western part, whereby it is not clear which part of the territory would be controlled by the more powerful Magdalenska gora.

SOCIAL STRUCTURE AND DIFFERENTIATION

The beginning of the Iron Age in Dolenjska is marked by a change in the funerary ritual. Cremation was gradually abandoned in favour of inhumation, flat cemeteries were being abandoned and the deceased buried under tumuli. This altered the layout of cemeteries, which reveals a new spatial concept as well as a tendency towards monumentality. Tumuli arranged in separate rows, in groups or singly along the roads leading to settlements, usually embraced several generations, men, women and children, whereby their graves were arranged in concentric circles around the central grave or around an empty centre. The distribution of graves within a tumulus as well as its construction is known primarily through modern excavations at Stična and Novo mesto (*figs.* 42, 43), whereby the tumuli at Stična were more thoroughly analysed and their burials considered from various aspects. The explanations proposed in connection with Stična by Gabrovec and Teržan represent a good basis for understanding the tumuli from other sites across Dolenjska and Bela krajina that were dug up considerably earlier and less systematically, an example of which are also the tumuli from Magdalenska gora. Based on the information concerning the place of burial, grave markers and the structure of grave goods, Gabrovec and Teržan interpreted tumuli as a mirror of a community based on family-kin relationships, within which formed a leading social stratum or family-kin aristocracy.¹⁶⁴⁴

STRUCTURE OF THE CEMETERY

Based on the analyses in the chapters above, the following conclusions as to the structure of the cemetery at Magdalenska gora can be drawn. Firstly, its inhabitants buried their dead, from the very beginning, at three separate locations. Secondly, the development of the cemetery did not follow the concept of simple horizontal stratigraphy. Thirdly, the dual burial rite was practiced until the beginning of the Late Hallstatt period. All these

¹⁶⁴³ See Chapter 4.8.2 on amber, *fig.* 105.

¹⁶⁴⁴ Gabrovec 1987, 109 ff; *id.* 2008, 56 f; Teržan 1995b; *ead.* 2008, 191 ff.

¹⁶⁴⁴ Gabrovec 1987, 109 ss; *id.* 2008, 56 s; Teržan 1995b; *ead.* 2008, 191 ss.

vzhodni polovici gomile.¹⁶⁴⁵ Na Magdalenski gori lahko sestavo gomil in razlike med njimi ugotovljamo le po številu pokopov (*sl. 12: B*), njihovem časovnem razponu (*sl. 129*) in bogastvu grobnih pridatkov (*sl. 39*).

Gomile z enim pokopom. V prvih dveh fazah razvoja magdalenskogorske skupnosti imamo domnevno opraviti z gomilami, ki so vsebovale en sam grob (*sl. 12*). Tako se vsaj zdi v primeru gomil 11 in 12 na skrajnem severnem robu grobišča na Laščiku ter gomile 4 na njegovem južnem koncu (na Terišču), čeprav o tem ne moremo biti povsem prepričani glede na način kopanja. V gomili 11 je Pečnik naletel na žganino in lončenino, najdbe pa žal niso ohranjene kot grobna celota. V gomili 12/1 je odkril kamnito skrinjo s sežganimi posmrtnimi ostanki pomembnega predstavnika iz najzgodnejše faze poselitve (= stopnja Podzemelj), v njegovi opravi pa lahko prepoznamo alpske prvine (dereze) in morda tudi ostanke čelade picenske provenience (*sl. 54: levo zgoraj*). V gomili 4 je bil pokopan prominenten pripadnik druge generacije (= stopnja Stična), ki je imel figuralno okrašeno čelado italskega porekla; z njim je bila morebiti pokopana družica, kar bi se dalo sklepati po ženskem nakitu (značilnem za jugovzhodnoalpsko nošo), ki je bil najden v bronastem vedru domnevno svetolucijske provenience.

Opisano situacijo bi si lahko razlagali na različne načine, kot na primer, da je v starejšem halštatskem obdobju veljala šega, po kateri je bil poglavar skupnosti pokopan ločeno od ostalega prebivalstva in ne kot *primus inter pares*.¹⁶⁴⁶ To ne bi bila posebnost Magdalenske gore, saj so gomile z enim pokopom znane še ponekod drugod na Dolenjskem.¹⁶⁴⁷ Možna pa je tudi drugačna razlaga, da je na Magdalenski gori poleg lokalnega prebivalstva prebivala manjša skupina tujcev, ki so odigrali pomembno vlogo pri vzpostavitvi trgovine na dolge razdalje ali v kaki drugi dejavnosti.¹⁶⁴⁸ V zvezi s tem vprašanjem je zanimiv primer grobišč v Dobrniču.¹⁶⁴⁹ Gomile na Revi, ki ležijo severno od naselja, so vsebovale po en samcat skeletni grob, med pridatki pa se pojavljajo ukrivljen meč (*mahaira*), prestižna konjska oprema, apulski krater ali lokalni posnetek le-tega in zbirka puščic, medtem ko gomile v Dobravi na južni strani naselja kažejo družinsko-rodovni značaj, saj je bilo v njih odkritih po več pokopov, med njimi pa so nekateri prav tako spadali v sam vrh dobrniške srenje. Teržanova je na osnovi razlike v številu pokopov in prostorske ločenosti gomil domnevala, da so bili v severni nekropoli pokopani pripadniki tamkajšnje elite.¹⁶⁵⁰

¹⁶⁴⁵ Teržan 2008, 233 ss.

¹⁶⁴⁶ Tak primer je znan npr. iz štajerskega Kleinkleina: Teržan 1990a, 132 ss, 205 s; Egg/Kramer 2005, 3 ss.

¹⁶⁴⁷ Teržan 2008, 222; primerjaj tudi Budinjak: Škoberne 1999, 23, sl. 7.

¹⁶⁴⁸ Teržan 2008, 213.

¹⁶⁴⁹ Parzinger 1988–1989.

¹⁶⁵⁰ Teržan 2008, 208 s.

conclusions indicate a segmented society composed of several social units that may have represented families of different provenance.

The structure of the tumuli at Magdalenska gora cannot be studied in as much detail as was the case with Tumuli 48 and 5 from Stična. The latter were studied by Teržan, who pointed out a bipolar division of the tumuli and showed that the place of burial depended on various factors rather than following only the paradigm of simple succession of burial in a circle. For example, the position of the deceased in the graves in the south-eastern part of Tumulus 48 followed a clockwise direction, while those in the north-west an anticlockwise direction (*fig. 42*). This divides the tumulus into two halves and reveals a dualistic organizing principle. Another interesting finding is that male burials group on the eastern half of the tumulus.¹⁶⁴⁵ At Magdalenska gora, the structure of tumuli and the differences among them can only be established on the basis of the number of burials (*fig. 12: B*), their chronological span (*fig. 129*) and the wealth of the grave goods (*fig. 39*).

Tumuli with a single burial. The first two phases of development of the Magdalenska gora community produced tumuli with single graves (*fig. 12*); this is supposed for Tumuli 11 and 12 on the northern edge of the cemetery at Laščik, as well as of Tumulus 4 on the southern end at Terišče. The method of excavation employed for these tumuli, however, prevents us from confirming the supposition. In Tumulus 11, for example, Pečnik found a burnt layer with pottery, though alas, the finds have not been preserved as a grave group. In Tumulus 12/1, he found a stone cist with cremated remains of an important representative from the earliest settlement phase (= Podzemelj phase), the outfit of whom reveals Alpine elements (crampons) and possibly also the remains of a helmet of Picene provenance (*fig. 54: top left*). Tumulus 4, on the other hand, contained a prominent member of the second generation (= Stična phase), who was buried with a helmet with figural decoration of Italic origin. Possibly buried with him was a female companion, as inferred from the female jewellery, typical of the south-eastern Alpine costume. The finds were placed into a bronze bucket of presumed Sveta Lucija provenance.

The situation described above, however, offer more than one possible explanation. It could also be understood as the chieftain of the community in the Early Hallstatt period being buried apart from the rest of the population and not as *primus inter pares*.¹⁶⁴⁶ This would not be particular to Magdalenska gora, since tumuli with single burials are known from several sites in Dolenjska.¹⁶⁴⁷ Another possible explanation is that the

¹⁶⁴⁵ Teržan 2008, 233 ff.

¹⁶⁴⁶ Such a situation is known, for example, in Styria at Kleinklein: Teržan 1990a, 132 ff, 205 f; Egg/Kramer 2005, 3 ff.

¹⁶⁴⁷ Teržan 2008, 222; cf. Budinjak: Škoberne 1999, 23, Fig. 7.

Gomile z več kot sto pokopi. Drugo skrajnost predstavljajo gomile z več kot sto pokopi, kar je redkost v dolensko-belokranjski regiji, kjer je po znanih podatkih bilo največ takih, ki so vsebovale do 30 grobov.¹⁶⁵¹ Na Magdalenski gori v tem pogledu izstopata dve gomili na Prelogah. Ena od teh je gomila 13, v kateri je bilo odkritih 175 grobov, ki ne kažejo krožne razvrstitve (*sl. 16*). Še več jih je menda vsebovala gomila 2, omenjata se številki 350 ali 400, ki sta zagotovo pretirani.¹⁶⁵² Za razliko od gomile 13, kamor so pokopavali neprekinjeno že od samega nastanka te skupnosti, je gomila 2 dozdevno nastala kasneje in je v eni generaciji štela skoraj toliko članov kot vse preostale gomile skupaj. Obe gomili dosežeta vrhunec v četrti fazi, v obeh je skoncentriranega veliko bogastva in dragocenih predmetov, največ prav v gomili 2. Vse to govori v prid domnevi, da sta predstavljali močni družinsko-gospodarski enoti v smislu grškega *oikos*.¹⁶⁵³ in sta v času stopnje certoških fibul obvladovali pomembne dejavnosti v tej skupnosti, njihovi člani pa bržkone niso bili zgolj sorodstveno povezani, saj je tako skokovito naravni prirast družinskih članov malo verjeten.¹⁶⁵⁴

O MESTU POKOPA

Centralni grobovi. Ob praviloma koncentrični razporeditvi pokopov v dolenskih gomilah izstopajo grobovi, ki so bili umeščeni v središče, zato se jim pripisuje poseben pomen. Običajno so bili obloženi in prekriti s kamnito grobljo ali kamniti ploščami, nekateri so bili prazni, izropani ali uničeni, drugi so vsebovali sežgane ali skeletne človeške ostanke. Teržanova je v razpravah o stiških gomilah opozorila, da je potrebno ločevati med tistimi, ki so predstavljali prvi pokop v gomili, in onimi, ki niso bili najstarejši. Iz njene analize izhaja, da so bili v stopnji Podzemelj v sredo gomile pokopani moški, največkrat v izstopajočih opravah, v katerih zasledimo skledaste čelade, kratke železne meče (*mahaire*), dragoceno konjsko opremo in tudi ostanke konja.¹⁶⁵⁵ V stopnji Stična pa je središčna lega v gomili pripadla tudi nekaterim ženskam, odetim v dragocena oblačila in nakit – nad pokojnico v gomili na Kapiteljski njivi v Novem mestu (gr. 14/34) so bile najdene celo konjske kosti in žvale¹⁶⁵⁶ –, medtem ko se v moških

population at Magdalenska gora also included foreigners, who may have played an important role in setting up either long-distance trade or some other activity.¹⁶⁴⁸ Of interest in connection with the latter are the cemeteries at Dobrnič.¹⁶⁴⁹ These, more precisely the tumuli at Reva to the north of the settlement, revealed single graves, whereby the grave goods included a *machaira* sword, prestige horse gear, an Apulian *krater* or its local imitation, as well as a collection of arrowheads. The tumuli at Dobrava along the southern edge of the settlement, on the other hand, show a family-kin character and revealed several burials each, some ranking among the most prominent of the Dobrnič community. Based on the difference in the number of burials and on the spatial separation, Teržan supposed the northern cemetery to be the burial site of a member of the local elite.¹⁶⁵⁰

Tumuli with over a hundred burials. On the other end of the scale are the tumuli with over a hundred burials, which represent a rarity in the Dolensko-Bela krajina region; most tumuli here contained up to 30 burials, according to the present knowledge.¹⁶⁵¹ At Magdalenska gora, two tumuli at Preloge stand apart in the number of graves. The first is Tumulus 13, which revealed 175 burials that do not show a circular distribution pattern (*fig. 16*). Even more graves were presumably found in Tumulus 2; the numbers 350 and 400 are mentioned, which are surely an exaggeration.¹⁶⁵² In contrast to Tumulus 13 that had been in use from the very beginning, Tumulus 2 is thought to have been formed later and numbered almost as many members in one generation as all the other tumuli together. Both tumuli reached a peak of burial in Phase IV, both showed a concentration of wealth and valuable goods, particularly so Tumulus 2. All this speaks in favour of the two tumuli representing two powerful households in the sense of the Greek *oikos*,¹⁶⁵³ which controlled the important activities in the community during the Certosa phase. Having said that, their members must have had other than merely family ties, since the high number of burials is unlikely to be explained by population growth alone.¹⁶⁵⁴

¹⁶⁵¹ Dular J. 2008, 427.

¹⁶⁵² Gabrovec 1975b, 200; Tecco Hvala/Dular/Kocuvan 2004, 26 ss. Pečnik jo je prekopal v več kampanjah, najdbe pa hranita muzeja v Ljubljani in na Dunaju. V dunajskem muzeju je iz te gomile inventariziranih 88 grobnih celot, dodatnih 15 smo uspeli delno rekonstruirati iz tipološko urejenih predmetov v ljubljanskem muzeju.

¹⁶⁵³ O pojmu *oikos* v antični ekonomiji je obširneje razpravljala Finley 1987, 17 ss; glej še Humphreys 1994.

¹⁶⁵⁴ Tecco Hvala/Dular/Kocuvan 2004, sl. 50.

¹⁶⁵⁵ Teržan 2008, 192 ss.

¹⁶⁵⁶ Taki primeri so poznani tudi v južni Italiji: D'Ercole 2000a, 466 s.

¹⁶⁴⁸ Teržan 2008, 213.

¹⁶⁴⁹ Parzinger 1988–1989.

¹⁶⁵⁰ Teržan 2008, 208 f.

¹⁶⁵¹ Dular J. 2008, 427.

¹⁶⁵² Gabrovec 1975b, 200; Tecco Hvala/Dular/Kocuvan 2004, 124 ff. Pečnik dug this tumulus in several campaigns. He sent a part of the finds to the museum in Ljubljana and the rest to the museum in Vienna, the latter comprising 88 grave groups. Among the typologically arranged finds in the Ljubljana museum, it was possible to reconstruct additional 15 grave groups.

¹⁶⁵³ See treatises on *oikos* in, for example, Finley 1987, 17 ff; Humphreys 1994.

¹⁶⁵⁴ Tecco Hvala/Dular/Kocuvan 2004, Abb. 50.

centralnih grobovih iz te kronološke stopnje pojavljajo deli hoplitske opreme (oklep, ščit) in uvoženo posodje. Da je sredina gomile predstavljala posvečen prostor, je moč sklepati še iz nekaterih drugih primerov, kjer so v osrednjem delu ležali raztresene sežgane kosti, pepel ali črepinje posod ter ostanki lesa.¹⁶⁵⁷

Strinjamo se lahko z razlago Teržanove, da je centralno mesto v gomili pripadalo resničnim ustanoviteljem družin oz. rodov ali mitičnim začetnikom v primeru kenotafov. V njih je moč slutiti kult prednikov, ki je značilen za družinsko-rodovne skupnosti. Bolj zapleteno je vprašanje, ali je šlo za čaščenje prednikov po moški liniji, kot bi lahko presojali po najstarejših takih pokopih z začetka železne dobe. To bi kazalo na "patrilokalna" razmerja, kar pomeni, da so se ženske po poroki preselile na možev dom in poslej skupaj z otroki pripadale njegovi skupnosti.¹⁶⁵⁸ Toda ta princip ni prisoten v vseh dolenskih gomilah, o čemer pričajo omenjeni ženski centralni grobovi iz stopnje Stična. Ob tem velja opozoriti še na drugo študijo Teržanove, v kateri je razčlenila strukturo grobov iz predhodnega obdobja, tj. časa kulture žarnih grobišč. Po njenih dognanjih je v tistem času osrednja vloga pripadala ženskam oz. prevladovalo matrilinearne razmerje.¹⁶⁵⁹ Iz tega bi lahko izhajal nasledek, da so v starejši železni dobi ene skupine obdržale žarnogrobiščno tradicijo, druge pa so se oprijele novega kanona, ki je za steber skupnosti v središče postavljaj moškega, kar pomeni korenit preobrat v mentaliteti in družbenih odnosih.

V zapiskih izkopavalcev na Magdalenski gori lahko najdemo indice, ki govorijo o tem, da so bili tudi tu nekateri grobovi umeščeni v sredino gomile in da so imeli posebno konstrukcijo,¹⁶⁶⁰ vendar pa na osnovi ohranjene dokumentacije takih grobov v najstarejših fazah ni mogoče jasno razpoznati. Na skici gomil na Laščiku (sl. 128: IX, X) imata središčno lego v gomilah grobova 9/7 in 10/12, ni pa znano, kaj je bilo najdeno v njih. Morda je osrednje mesto zavzemal tudi prazen ali izropan grob v gomili 8, ki je bil obdan s kamnitimi ploščami (8/3). Prav tako lahko samo ugibamo, ali je najgloblji grob v gomili V na Laščiku ležal v sredini ali ne; v njem je bila pokopana ženska, opravljena z zlatimi lističi, jantarjem in vijčkoma (V/32).¹⁶⁶¹ Pojav centralnih grobov na Magdalenski gori lahko razločneje zaznamo šele v mlajši certoški stopnji (2/13, 13/55) in v zgodnjem negovskem času (V/29), torej proti koncu njenega razvoja. Podobni primeri so zabeleženi še na nekaterih drugih

PLACE OF BURIAL

Central graves. The standard concentric distribution of burials in the tumuli of Dolenska sometimes includes graves that occupy a central position and are therefore considered of special significance. They were usually surrounded and covered by stones or stone slabs, some were empty, destroyed or robbed, while others contained human remains either as cremations or as inhumations. In her discussions on the tumuli from Stična, Teržan pointed out the necessity to distinguish between the central graves that represented the first burial in a tumulus, and those that were not of the earliest date. Her analysis showed that, in the Podzemelj phase, the tumulus centres were occupied by burials of men, most often with an outstanding outfit that included bowl-shaped helmets, short iron swords or *machairas*, valuable horse gear and also remains of horses.¹⁶⁵⁵ In the Stična phase, the central positions could also be occupied by burials of women, clad in valuable garments and adorned by rich jewellery. The woman buried at Kapitelska njiva in Novo mesto (Gr. 14/34) even had horse bones and bridle-bits above the skeleton.¹⁶⁵⁶ The male central graves from this phase revealed parts of hoplite equipment, such as cuirasses and shields, but also imported vessels. Additional evidence of the centre representing a consecrated spot in the tumulus is provided by examples that revealed cremated bones, ashes, pottery shards and remains of wood strewn across the central part.¹⁶⁵⁷

One can concur with the explanation proposed by Teržan, of the central spot in a tumulus reserved for either founders of families or mythical beginners of clans, as in the case of cenotaphs. This implies an ancestor cult, which is a characteristic of family-kin communities. A more complex question is whether ancestor veneration followed the male lineages, as could be surmised on the basis of the earliest central graves from the beginning of the Iron Age. This would point to a patrilocal system, where women after marriage settled in the husband's home and, together with children, belonged to his family.¹⁶⁵⁸ This principle, however, is not observable in all the tumuli in Dolenska, as proven by the above-mentioned female central graves from the Stična phase. In another study, Teržan analysed the structure of graves from the previous period, i.e. Urnfield culture period. At that time, as she established, it was the women who had the central role within a society and the matrilinear kinship principle prevailed.¹⁶⁵⁹ This could lead

¹⁶⁵⁷ Glej npr. Dular J. 2003, sl. 109, 110, 123, 124.

¹⁶⁵⁸ Ta pojem uporabljam v pomenu, kot ga je definiral Radcliff-Brown, ki se je ukvarjal s sorodstvenimi sistemi pri različnih primitivnih oz. tradicionalnim družbah (Radcliff-Brown 1994, 30 ss, 40 ss, 183 ss).

¹⁶⁵⁹ Teržan 1987, Fig. 4; ead. 1995a, Abb 13, 27; ead. 1999, 139.

¹⁶⁶⁰ Tecco Hvala/Dular/Kocuvan 2004, 104.

¹⁶⁶¹ Hencken 1978, 38, Fig. 152.

¹⁶⁵⁵ Teržan 2008, 192 ff.

¹⁶⁵⁶ Such examples are also known in southern Italy: D'Ercole 2000a, 466 f.

¹⁶⁵⁷ See, for example, Dular J. 2003, Abb. 109, 110, 123, 124.

¹⁶⁵⁸ I borrowed the term patrilocal from Radcliff-Brown, who studied kinship systems of the so-called primitive or traditional societies (Radcliff-Brown 1994(1952)).

¹⁶⁵⁹ Teržan 1987, Fig. 4; ead. 1995a, Abb 13, 27; ead. 1999, 139.

dolenjskih najdiščih (Dolenjske Toplice, Novo mesto, Libna). Ti grobovi zagotovo ne predstavljajo skupnega prednika, prej bi v njih lahko slutili kult osebnosti ali apoteozo oz. heroizacijo posameznikov, ki so si častno mesto v skupnosti pridobili s posebnimi zaslugami, vrlinami ali junaštvu.¹⁶⁶² Glede na to, da so bili pokopani skupaj z drugimi člani, pa si njihov položaj lahko razlagamo kot prvega med enakimi (*primus inter pares*).

Periferni grobovi. Antipod centralnim pokopom predstavljajo periferni grobovi, ki ne spadajo med kronološko najmlajše pokope znotraj gomil, kakor bi po idealni shemi pokopavanja pričakovali. Na Magdalenski gori velja v tem smislu opozoriti na dva grobova v gomili 13, ki nista niti najstarejša ne najmlajša (13/10 in 13/163). Oba sta bila domnevno žarna, časovno pa spadata na prehod iz starejšega v mlajše halštatsko obdobje. Grob 13/10 je ležal na severozahodnem koncu gomile (sl. 16),¹⁶⁶³ v njem so bili najdeni apulska kraterja, bodalo, sulici in brus, kar kaže na pokop moškega. Drugi (ženski) grob je bil odkrit na vzhodnem robu gomile, vseboval je t. i. svetolucijski pitos s številnim obročastim nakitom, fibulami s stekleno in koščeno oblogo ter obeskom v podobi rogatih živali, razen tega so bile v njem najdene še nesežgane ovčje ali kozje koščice.¹⁶⁶⁴ Po periferni legi v gomili, načinu pokopa (sežiganje takrat ni bilo več v navadi) in posodah, širokolistni sulični osti in fibuli s koščeno oblogo italskega porekla bi lahko domnevali, da sta bila prišleka, ki nista pripadala lokalnemu prebivalstvu oz. sta bila s člani te skupnosti v drugačnem razmerju.¹⁶⁶⁵ To pa bi pomenilo, da ta skupnost ni temeljila zgolj na (krvnih) sorodstvenih povezavah in dejanskih skupnih prednikih, temveč je bila vsaj deloma eksogamna¹⁶⁶⁶ in morebiti prav zato nekatere gomile niso imele centralnih grobov v smislu skupnih družinsko-rodovnih prednikov.

O ANTROPOLOŠKIH IZSLEDKIH

Nekaj namigov o strukturi prebivalstva in njihovih povezavah lahko dobimo v antropoloških študijah. Žal pa z vidika fizične antropologije prebivalce te regije iz

¹⁶⁶² Teržan 2008, 201 ss.

¹⁶⁶³ V Szombathyjevem dnevniku sta za ta grob zabeleženi dve merski točki in skica lege predmetov ter pripomba, da je bil v bližini najden še kos železnega okova, medtem ko je grob 13/6 po njegovih merskih podatkih ležal 60–90 cm višje: Tecco Hvala/Dular/Kocuvan 2004, 54 s, sl. 29.

¹⁶⁶⁴ Ibid., 55, 78 s, sl. 28, 29, 39, 49, T. 68, 69A, 123, 124.

¹⁶⁶⁵ Na podoben primer je opozoril tudi Gabrovec v zvezi z gomilo 48 v Stični, kjer je žgan pokop 48/30 iz tretje faze pokopavanja umeščen na rob gomile, v posebnem odnosu pa sta tudi grobova 48/141 in 48/142a (Gabrovec 2008, 41 s, 57, sl. 23).

¹⁶⁶⁶ Sklicujem se na Radcliff-Brownovo opredelitev klana (Radcliff-Brown 1994, 62 ss).

to a conclusion that some communities in the Early Iron Age retained the Urnfield culture tradition, while others adopted the new canon that placed the man as the pillar of community, which also signifies a fundamental shift in mentality and social relationships.

Notes of the excavators at Magdalenska gora offer clues as to some of the graves being placed centrally within tumuli and having a particular construction,¹⁶⁶⁰ though the preserved documentation does not allow us to clearly identify such graves in the earliest phases. The sketch of the tumuli from Laščik (fig. 128: IX, X), for example, shows that Graves 9/7 and 10/12 occupied the central positions, though their contents are not known. Possibly also centrally placed was Grave 8/3, in Tumulus 8, surrounded by stone slabs and either empty or robbed. Another example is the deepest lying grave (V/32) in Tumulus V at Laščik, for which it is not possible to determine whether it had a central position or not. It contained the burial of a woman adorned by gold leaves, amber and two spindle whorls.¹⁶⁶¹ The identification of central graves at Magdalenska gora only becomes more certain in the Late Certosa (2/13, 13/55) and Early Negova phases (V/29), that is towards the end of the Early Iron Age. Examples of central graves from these phases were also recorded on other sites in Dolenjska (Dolenjske Toplice, Novo mesto, Libna). These graves, however, certainly do not represent a common ancestor; they could sooner be seen as an expression of the cult of personality, apotheosis or heroization of individuals that had earned a pride of place within a community through merit, virtue or heroic acts.¹⁶⁶² Considering the fact that they were buried together with other members, their position can only be seen as that of a *primus inter pares*.

Peripheral graves. Antipodes to the central graves are peripheral graves that do not date among the chronologically latest burials within tumuli, as it could be anticipated considering the ideal model of burying. At Magdalenska gora, two such graves in Tumulus 13 should be mentioned that are neither the earliest nor the latest. Graves 13/10 and 13/163 are presumably both cremations and date to the transition from the Early to the Late Hallstatt period. Grave 13/10 was situated on the north-western edge of the tumulus (fig. 16)¹⁶⁶³ and revealed two Apulian *kratere*, a dagger, two spears and a whetstone, which indicates the burial of a man. The second, female Grave 13/163 was found on the eastern edge of the tumulus and yielded

¹⁶⁶⁰ Tecco Hvala/Dular/Kocuvan 2004, 182.

¹⁶⁶¹ Hencken 1978, 38, Fig. 152.

¹⁶⁶² Teržan 2008, 201 ff.

¹⁶⁶³ In his diary, Szombathy recorded two measurement points for this grave. He also sketched the position of finds in the grave and noted that a piece of iron was found in the vicinity. His records also show Grave 13/6 to have been found 60–90 cm above Grave 13/10: Tecco Hvala/Dular/Kocuvan 2004, 54 f, Abb. 29.

starejše železne dobe bolj slabo poznamo, ker se organski ostanki v dolenski kisli zemlji komajda ali sploh ne ohranijo. Mestoma so sicer bile opravljene osteološke analize, toda vzorec je v celoti gledano majhen in ni ovrednoten v obliki sinteze.¹⁶⁶⁷

V začetnem poglavju te knjige so predstavljeni izsledki analiz človeških kosti z Magdalenske gore v Mecklenburški zbirki, ki jih je pred štirimi desetletji in pol opravil Angel.¹⁶⁶⁸ V morfologiji lobanj je prepoznal značilne poteze alpske populacije, ki so prevladovala, in v malo manjši meri tudi mediteranske poteze. Na osnovi tega je predpostavljal, da je bila magdalenskogorska skupnost v zasnovi heterogena in da je do mešanja prebivalstva prišlo kake tri generacije prej. Pozneje se je bolj zaprla, kar naj bi odražale fenotipske značilnosti lobanj, ki kažejo na rekombinacije specifičnih lokalnih potez in na domnevno križanje sorodstvenih skupin. Veliko podobnost je zaznal med nekaterimi moškimi pripadniki iste gomile (npr. X/20, X/25, X/57), na drugi strani pa npr. med moškim iz gomile IV (IV/10) in žensko iz gomile X (X/3), kar bi pritrjevalo domnevi o "patrilokalnih" razmerjih.

Ugotovil je tudi, da so ženske umirale v povprečju pri 31 letih oz. devet let mlajše od moških, med vzroki za njihovo zgodnejšo smrt pa je predpostavljal umrljivost pri porodih in težaško delo, medtem ko je za mladega moškega iz groba X/25 domneval, da je podlegel smrtonosnemu udarcu z ostrim predmetom po glavi; lahko bi si predstavljali, da je življenje izgubil v boju. Na moški lobanji iz nekega uničenega groba pa je opazil sledi *trepanacije*, kar pomeni, da so v tej sredini obstajali zdravilci, ki so že opravljali kirurške posege.

Prav tako so zanimiva opažanja izkopavalcev o izjemni telesni višini nekaterih žensk, ki so imele za povrh bogate pridanke in oprave (npr. 2/a, 13/117). Menda so bili tudi v zahodnohalštatskem krogu pripadniki in pripadnice elite pogosto nadpovprečno visoki, kar naj bi kazalo na razlike v prehrani prebivalstva.¹⁶⁶⁹

Ob skromnem in naključnem antropološkem vzorcu pa lahko spolno in starostno strukturo magdalenskogorske skupnosti ter gmotni položaj in status njenih članov še najboljše razločimo po grobnih pridatkih in opravah.

O DIFERENCIACIJI MOŠKIH

Z novimi družbenimi normami se je v starejši železni dobi na Dolenjskem uveljavila navada prilaganja orožja v grob, kar olajšuje identifikacijo moških pokopov. Poleg orožja so med značilne prvine moških oprav in pridatkov spadale še pasne spona in konjska oprema pa brusni kamni ter šila, nekateri so nosili

a Sveta Lucija pithos with a multitude of ring jewellery, with fibulae with a glass and bone overlay and pendant in the shape of horned animals, but also small, unburnt caprovid bones.¹⁶⁶⁴ Their peripheral position, burial rite (cremation no longer being practiced at that time), vessels, broad-bladed spearhead and fibula with a bone overlay of Italic origin could lead us to see them as foreigners, who were not members of the local community and were in a different relationship to them.¹⁶⁶⁵ This would also signify that the community was not based solely on common family-kin ancestors, but was at least in part exogamous.¹⁶⁶⁶ This might explain why some tumuli did not have a central grave.

ANTHROPOLOGICAL FINDINGS

The structure of the population and their inter-relationships can also be glimpsed at with the aid of the findings of anthropological studies. The acid soil of Dolenjska, alas, prevented the human remains from being well preserved or preserved at all, which in consequence leads to a very poor knowledge on the Early Iron Age inhabitants of the region from the point of view of physical anthropology. Osteological analyses have been performed, but the sample in view of the whole region is small and has not been synthetically assessed.¹⁶⁶⁷

The beginning of this book presented the findings of the analysis performed by Angel four decades ago on the human bone remains from Magdalenska gora kept within the Mecklenburg Collection.¹⁶⁶⁸ He found that the morphology of the skulls shows a prevalence of the characteristic traits of the Alpine population, in a small measure also those of the Mediterranean population. On this basis, Angel supposed that the Magdalenska gora community was heterogeneous at its conception and that the mixing of population occurred some three generations earlier. The community later became more isolated, as indicated by phenotypical traits on the skulls that reveal recombinations of specific local traits and presumably crossing over of linkage groups. He observed numerous similarities between certain male members of the same tumulus (for example from Graves X/20, X/25 and X/57), but also between a man from Tumulus IV (IV/10) and a

¹⁶⁶⁴ *Ibid.*, 55, 78 f, Abb. 28, 29, 39, 49, T. 68, 69A, 123, 124.

¹⁶⁶⁵ Similar examples are known from Tumulus 48 in Stična. Gabrovec pointed to cremation Grave 48/30 from the third phase of burring, which was placed on the edge of the tumulus; Graves 141 and 142a were also in a specific relationship (Gabrovec 2008, 41 f, 57, Abb. 23).

¹⁶⁶⁶ I refer to Radcliff-Brown's definition of a clan (Radcliff-Brown 1994(1952)).

¹⁶⁶⁷ Angel 1968; Brodar 1968; Dolinar-Osole 1956; Tomazo-Ravnik 1982; *ead.* 1984; Gabrovec *et al.* 2006.

¹⁶⁶⁸ See Chapter 1.1.3 on anthropological remains, *fig.* 5 and *fig.* 6.

¹⁶⁶⁷ Angel 1968; Brodar 1968; Dolinar-Osole 1956; Tomazo-Ravnik 1982; *ead.* 1984; Gabrovec *et al.* 2006.

¹⁶⁶⁸ Glej poglavje 1.1.3 o antropoloških ostankih, *sl.* 5 in *sl.* 6.

¹⁶⁶⁹ Arnold/Gibson 1995, 8.

Fibule Fibulae	Narokvice Arming	Pas Belt	Sekira Axe	Sulice Spears	Nož Knife	Puščice Arrows	Laščik	Preloge							Voselca	Skupaj Total
							Gom. / Tum.	Gom. / Tum.								
							V	2	IV	VI	VII	VIII	X	13		
			■	■			1	9	1	2	3		4	5	1	26
				■			5	5	4		1	1	2	6	1	25
					■		1		2				3	11	3	20
			■				4	2	6					5		17
				■		■	4				2	3	1	4		14
										1		1	1	8		11
			■	■	■		1	4		2	1			1		9
				■	■			1	1	2	1		2			7
		■		■	■		1		1	1	1	1		2		7
		■			■		1		1			1	2	1		6
■		■		■	■		2	1	2	1						6
■		■	■	■	■			3			1			2		6
■			■				2				1	1	1	1		6
■			■	■				1	1		1		1		1	5
■		■			■		1	1			1			2		5
		■	■	■	■							1	2	2		5
		■	■	■	■		1	1		1		1		1		5
		■		■				1					1	2		4
	■	■	■	■	■			1					2			3
■	■		■	■	■			1					2			3
■		■			■			1					1		1	3
■					■				1				1	1		3
■	■		■					1			1					2
■		■	■					1	1		1					2
■		■	■	■				1					1			2
■				■				1								1
■			■	■	■									1		1
■			■	■	■									1		1
	■		■	■							1					1
	■		■	■									1			1
	■	■	■	■		■		1								1
		■	■	■		■		1								1
		■		■		■								1		1
čelada / helmet							3	5	2		1			2		13+2
meč ali bodalo / sword or dagger							3							1		4
žezlo ali raženj / mace or spit							2	4						1		7
konj / horse							3	3	4		1			2		12+1

Sl. 133: Spekter moških oprav po posameznih gomilah na Magdalenski gori
(n = število grobov z določeno vrsto ali kombinacijo pridatkov).

Fig. 133: Variants of the male outfit in individual tumuli at Magdalenska gora
(n = number of graves with a particular combination of objects).

tudi narokvice. Te prvine je na Magdalenski gori moč zaslediti v vseh možnih povezavah (sl. 133). Na osnovi kriterija frekventnosti posameznih kombinacij (<10>) lahko moške oprave v grobem delimo na tri skupine. V prvi skupini, ki je najštevilnejša in zajema več kot polovico moške populacije (ok. 54 %), so zastopane bolj skromne oprave, v katerih ni ne fibul ne narokvic (kar je tudi kronološko pogojeno), pasna spona je redka, orožje pa ne nastopa v "popolnih" kompletih. Predstavnike te skupine zasledimo v vseh gomilah.¹⁶⁷⁰ Drugo številčno

¹⁶⁷⁰ Glej tu poglavje 3.3 o grobnih pridatkih.

female buried in Tumulus X (X/3), which would speak in favour of the patrilineal system.

Angel also established that the average age of women at death was 31 years, which is nine years younger than men, while the causes of this earlier demise would include death at childbirth and hard work. For the young man buried in Grave X/25, he supposed death by mortal blow with a sharp object to the head, possibly in battle. The skull of a man from a destroyed grave even showed traces of *trepination*, indicating that the community was already familiar with healers performing surgical interventions.

Faze / Phases	Laščik	Preloge				Laščik
I	12/1					
II		4/1	IV/3	13/95		
III			IV/43?		VII/39	
IV				13/55 13/119		2/57 2/13 2/38 2/g 2/b
V			IV/32			V/6-7 V/29 V/19-20 V/26

Sl. 134: Sosledje vodilnih moških grobov po razvojnih fazah magdalenskogorske skupnosti.

Fig. 134: Succession of the leading male graves according to the phases of development of the Magdalenska gora community.

skupino (ok. 42 %) tvorijo nekoliko bolje opremljeni moški, mnogi med njimi so imeli bolj "popolne" komplete orožja, razen tega še fibule, pasne sponse, nekateri celo narokvice. Tudi pripadnike te skupine najdemo v vseh gomilah. V tretjo skupino, ki je najmanj številna (ok. 4 %), pa lahko uvrstimo posameznike, ki so imeli enkratne oprave, v katerih nastopajo čelade, bodala, meči, žezla, ter razne luksuzne pridatke, kot so različni bronasti posodje, nekaterim je bil žrtvovan celo konj. Take eminentne predstavnike srečamo v gomilah IV, VII, 2 in 13 na Prelogah ter v gomili V na Laščiku. Razen tega so moški prepoznani še v skupini grobov brez vsakršnih pridatkov;¹⁶⁷¹ te skupine ne moremo kvantitativno ovrednotiti, ker je bil vzorec antropološke analize omejen le na 28 okostij iz treh gomil.

Diferenciacijo in rangiranje moških si je možno razlagati kot posledico njihovih različnih družbenih vlog in statusov. Glede na ugotovitev, da so domala v vsaki gomili zastopane vse te skupine oz. družbene kategorije moških, bi lahko sklepali na obstoj družinsko-rodovne hierarhije, ki je nemara temeljila na zaporedju rojstev in primatu prvorojenca, pa tudi na sposobnostih, starostnih razlikah ter delitvi dela in odgovornosti znotraj družinsko-produkcijskih enot. Ob tem je v vsaki generaciji moč opaziti več izstopajočih mož s podobnim statusom oz. položajem, ki so bili pokopani v različnih gomilah. V njih bi lahko videli v prvi vrsti družinske staršine oz. gospodarje, ki pa niso imeli vselej enakovrednih naslednikov (sl. 134 in sl. 135). Med veljaki srenje,

¹⁶⁷¹ Kot moške je Angel opredelil kostne ostanke iz grobov IV/10, IV/25, X/6, X/7: Angel 1968, 78, 95, 96, Fig. 1, 10, 12, 13.

Also of interest are the observations noted by the excavators on the extreme length of some of the female skeletons, which also boasted rich grave goods (for example from Graves 2/a, 13/117). It has to be mentioned that members of the elite in the West Hallstatt circle are thought to have been very tall as a result of better nutrition.¹⁶⁶⁹

The anthropological sample is small and randomly selected. For this reason, the sex and age structure of the Magdalenska gora community, as well as its material wealth and status of its members can best be assessed on the basis of grave goods and costume.

DIFFERENTIATION OF MEN

New social norms in the Early Iron Age Dolenjska brought about the custom of offering weapons in graves, which helps in identifying male burials. Apart from weapons, the male outfit and grave goods was further characterized by belt clasps, horse gear, whetstones and awls, some men also wore armlets. These objects appear at Magdalenska gora in a variety of combinations (fig. 133). Based on the frequency of individual combinations (<10>), the male outfit can be divided into three groups. The first group is most numerous and includes more than a half of the male population (ca. 54%). Its outfit is relatively poor and includes neither fibulae nor armlets (which is also chronologically conditioned), belt clasps are rare, while the weapons do not appear in "complete" sets. The representatives of this group are to be found in all tumuli.¹⁶⁷⁰ The second group (comprising ca. 42% of the male population) is constituted by somewhat better equipped men, many with more complete sets of weapons, but also wearing fibulae, belt clasps, some even armlets. The men of this outfit group can also be found in all tumuli. The third and least numerous group (ca. 4%) is comprised of individuals with an exceptional outfit boasting helmets, daggers, swords, maces, as well as luxury goods such as spits and bronze vessels; some of the men in this group even had an offering of a horse. These eminent members of the community were buried in Tumuli IV, VII, 2 and 13 at Preloge and Tumulus V at Laščik. Apart from the above, there were also men buried without grave goods.¹⁶⁷¹ These, however, cannot be quantified, since that would depend exclusively on anthropological determination of sex and such a determination was only performed on 28 skeletons from three tumuli.

The differentiation and ranking of men can be understood as a consequence of their different social roles and statuses. The observation that the above-discussed

¹⁶⁶⁹ Arnold/Gibson 1995, 8.

¹⁶⁷⁰ See Chapter 3.3 on grave goods.

¹⁶⁷¹ Angel determined the anthropological remains from Graves IV/10, IV/25, X/6, X/7 as male (Angel 1968, 78, 95, 96, Figs. 1, 10, 12, 13).

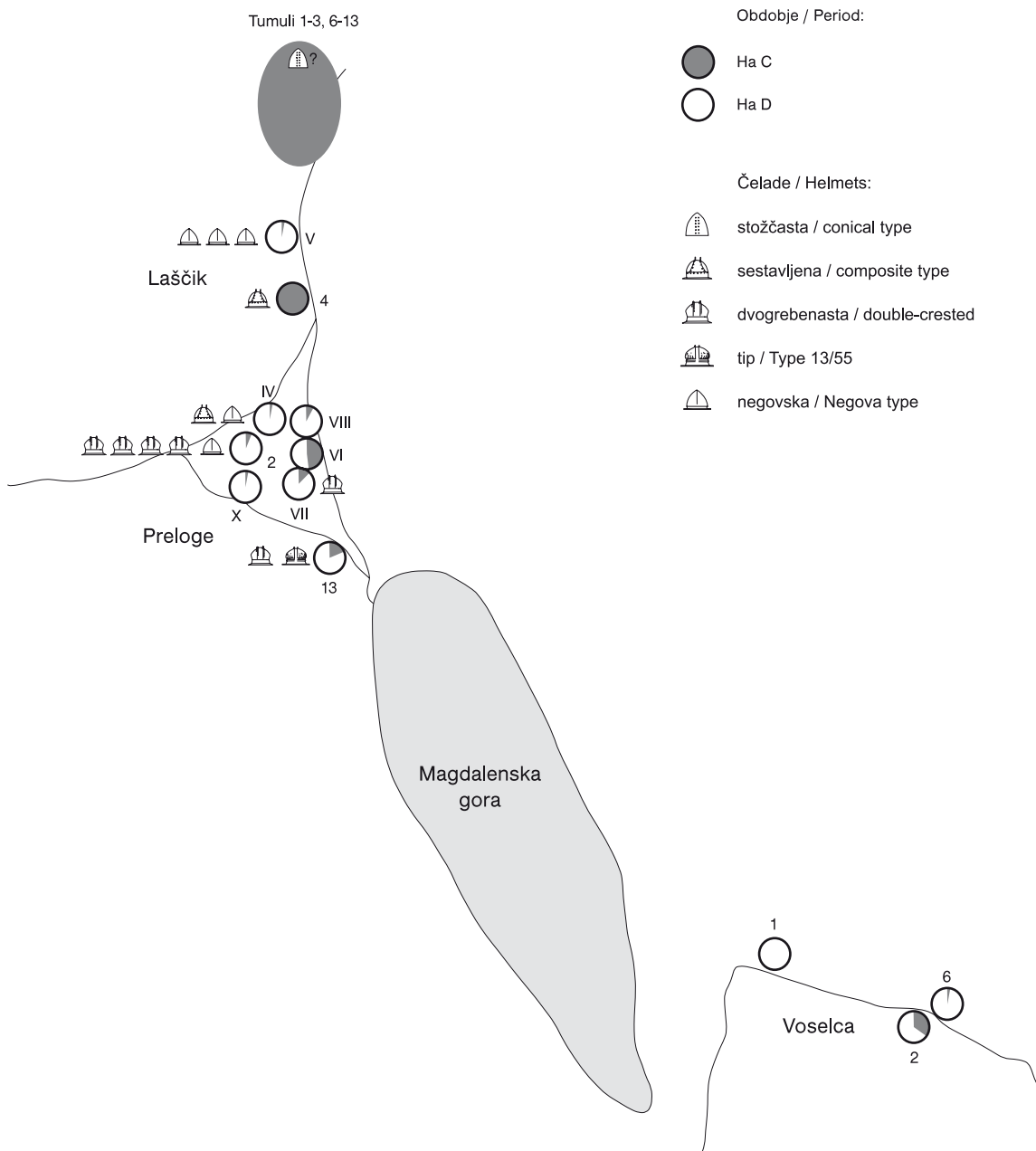

Sl. 135: Shematičen prikaz razvoja nekropole in lege grobov s čeladami.

Fig. 135: Schematic representation of the development of the cemetery with marked locations of graves with helmets.

ki so se lahko ponašali z materialnim in simbolnim "kapitalom", so verjetno izbirali vrhovnega poglavarja, vendar očitno ne vedno iz iste družine ali rodu, zato bi težko govorili o dinastični obliki in descendenčnem principu pri izbiri poglavarja srenje.¹⁶⁷²

Ob predpostavki, da lahko najbolj častivredne može prepoznamo po posebnem mestu pokopa ali

¹⁶⁷² Dular/Tecco Hvala 2007, 239 ss; Dular J. 2008, 430. Teržanova zagovarja nekoliko drugačno stališče in predpostavlja zametke dinastičnih oblik (Teržan 2008, 270 ss).

groups or social categories of men are present in almost all the tumuli could point to an existence of a family-clan hierarchy based on the succession of birth and primacy of the firstborn, but also on capability, age difference, division of work and responsibility within particular households. In each generation, we can observe several men from different tumuli that stand apart and have a similar status or position. They might be seen primarily as heads of families that did not always have worthy successors (fig. 134 and fig. 135). These men of note, who

grobno oboležju oz. konstrukciji, po vojaških oz. poglavarških insignijah ali ceremonialnem posodju, bi vodilno mesto v prvi fazi razvoja magdalenskogorske srenje lahko prisodili pokojniku 12/1 z Laščika (*sl. 54: levo zgoraj in sl. 134*). Poglavarja te srenje v drugi fazi bi lahko prepoznali v moških 4/1 z Laščika in IV/3 s Prelog (*sl. 54: v sredini zgoraj*), oba sta imela sestavljeno čelado, ki predstavlja statusni simbol istega ranga, pri čemer ni jasno, kdo je od koga prevzel oblast, ker preciznejše kronološke razlike med njima ni mogoče ugotoviti. V tretji fazi je vodilni položaj verjetno zavzemal konjenik VII/39 s Prelog, ki je imel sploh prvi na Dolenjskem dvogrebenasto čelado. Proti koncu te faze je vodstvo nemara prevzel konjenik 2/57 s Prelog, ki je prav tako nosil dvogrebenasto čelado (*sl. 54: levo spodaj*). V četrti fazi je njegov družinski klan postal daleč najmočnejši v vsej dolenjski regiji. Kar trije njihovi člani so se ponasjali z dvogrebenastimi čeladami (2/g, 2/13, 2/38), prestižne pridanke pa so imeli še nekateri drugi pripadniki tega klana (2/b, 2/d, 2/k, 2/46, 2/58). Najmočnejšega moža med njimi bi lahko videli v konjeniku 2/13 (*sl. 54: v sredini spodaj*), ki je imel še veliko zbirko pušičnih osti, žezlo in dereze ter najlepše ozaljšanega konja na Dolenjskem. Morda je bil poveljnik nekakšne bojne formacije ali vodja karavane, ki je na dolgih poteh čez tuje dežele potrebovala vojaško zaščito. Po rangu mu je bil enakovreden pripadnik druge velike gomile na Prelogah (13/55), ki sicer ni imel konja, imel pa je unikatno čelado z narebreno kaloto, žezlo in dragoceno bronasto posodje za banket (*sl. 34: A*); iz iste gomile in generacije je znan še konjenik z dvogrebenasto čelado in bronasto situlo (13/119). Ob koncu te faze pa se je v vrh magdalenskogorske elite prerinil konjenik iz kroga gomile V na Laščiku (V/6–7a–7). V peti fazi je njegov družinski klan prevzel vodilno vlogo z bojevnikom, ki sta bila skupaj pokopana v grobu V/29 (*sl. 54: desno spodaj*). Imela sta negovski čeladi in žezlo pa zgodnjelatenski meč, ki je predstavljal posebnost in novost v dolenjski skupnosti, ter še kup drugih luksuznih predmetov; žrtvovani so jima bili štirje konji, kar je bila prav tako rariteta na tem območju. Z zgodnjelatenskima mečema sta bila opremljena še dva člana te gomile (V/19–20 in V/26a), s čelado domnevno negovskega tipa (čeladi sta namreč izgubljeni) pa pripadnika 2/1–2 in IV/32 s Prelog.

Razen konjeniške elite nakazuje vojaško hierarhijo širok spekter moških oprav, v katerih je orožje zastopano v različnih kombinacijah (*sl. 45: B*). Ti moški so nemara predstavljali pehotne enote, ki so jih sestavljali bojevniki, oboroženi s sekirami in/ali sulicami (*sl. 55*). Vojaška hierarhija v starejšem halštatskem obdobju še ni tako izrazito stratificirana¹⁶⁷³ in je orožje verjetno skupaj s konji predstavljalo predvsem prestiž (*sl. 38*). V mlajšem halštatskem obdobju pa se je število oboroženih pripadnikov občutno povečalo, njihova oprema kaže na rangiranje, oborožitev je bolj standardizirana, zlasti

boasted material as well as symbolic worth, probably also constituted the pool from which the chieftain of the community was chosen. The chieftain does not appear to have always been chosen from the same family, which precluded a dynastic succession and a descendant principle in the choice of the chieftain.¹⁶⁷²

On the supposition that the most noteworthy men can be identified on the basis of a particular place of burial, grave marker or construction, as well as military and/or chieftain's insignia or ceremonial vessels, the leading role in the first phase of the development of the Magdalenska gora community could be accorded to the man buried in Grave 12/1 at Laščik (*fig. 54: top left and fig. 134*). In the second phase, chieftains could be seen in the two men from Grave 4/1 at Laščik and IV/3 at Preloge, respectively (*fig. 54: top centre*), both of whom had a composite helmet that represented a status symbol. Their succession is unclear, since we cannot establish a more precise chronological difference between them. The leading role in the third phase was probably played by the horseman buried in Grave VII/39 at Preloge, who was the first to boast a double-crested helmet in Dolenjska. The leading position towards the end of this phase may have been taken over by the horseman buried in Grave 2/57 at Preloge, also wearing a double-crested helmet (*fig. 54: bottom left*). In Phase IV, his clan became by far the most powerful across the whole of Dolenjska. As many as three of its members boasted double-crested helmets (2/g, 2/13, 2/38), while prestigious goods were also found in graves of other members of this clan (2/b, 2/d, 2/k, 2/46, 2/58). The most powerful man among them could be seen in the horseman buried in Grave 2/13 (*fig. 54: bottom centre*), whose horse was the most beautifully adorned in all of Dolenjska, but who also had a collection of arrowheads, a mace and crampons. He may have been a commander of a military formation, or the chief of a caravan that needed military protection on their voyage through foreign lands. Equal to him in rank was a member of another large tumulus from Preloge (13/55), who was not buried with a horse, but did have a unique helmet with a ribbed skull, a mace and valuable banqueting vessels made of bronze (*fig. 34: A*). The same tumulus held another horseman, with a double-crested helmet and a bronze situla (13/119). At the end of this phase, the top position of the Magdalenska gora community was occupied by the horseman buried in Tumulus V at Laščik (V/6–7a–7). His clan took over the leading role in the fifth phase, with two warriors buried together in Grave V/29 (*fig. 54: bottom right*). They were equipped with Negova helmets, mace and an Early La Tène sword – the latter represented a novelty within the Dolenjska community – and other items of luxury. Four horses were sacrificed with them, which is a rarity in the region. An Early La Tène sword was also offered to two

¹⁶⁷² Dular/Tecco Hvala 2007, 239 ff; Dular J. 2008, 430. Teržan gives a different explanation on the supposition of a dynastic form in the very beginning (Teržan 2008, 270 ff).

¹⁶⁷³ Teržan 1985.

s tulasto sekiro, ki je prepoznavni znak dolenskih bojevnikov tistega časa. Na osnovi tega smemo domnevati, da so se dolenske srenje vsaj občasno povezale v skupno vojaško zvezo oz. konfederacijo,¹⁶⁷⁴ kar bi pomenilo nov korak v organiziranosti družbe.¹⁶⁷⁵

Na drugi strani nam pogled v predstavnici svet takratnih ljudi odstira situlska umetnost. V detajlih figuralnih upodobitev opazimo posamične prvine, ki imajo pendant v grobnih pridatkih, zato lahko predpostavljamo, da se sama pripoved nanaša na konkretne dogodke iz njihovega vsakdanjega in prazničnega življenja. Na situlskih spomenikih so moški upodobljeni v vlogi ribičev in oračev, v kulturnih opravilih (kot je žrtvovanje živali), pri lovu in še pogosteje kot rokoborci, konjeniki, bojevniki. Iz likovne govornice je prav tako moč razbrati obred posvetitve poglavarjev in prenos oblasti. Pomensko večplastnost teh prizorov pa kažejo študije, posvečene tej tematiki.¹⁶⁷⁶

O DIFERENCIACIJI ŽENSK IN OTROK

Diferenciacija je opazna tudi v ženskih in otroških opravah (sl. 136). V prvo skupino bi po izbranem kriteriju lahko uvrstili več kot polovico ženske in otroške populacije (ok. 55 %) z bolj skromnimi opravami (brez nanožnic in ovratnic), ki jih zasledimo v vseh gomilah. V tej skupini oprav največkrat nastopajo fibule kot edini kos noše, pri čemer pa te niso indikativne samo za žensko oz. dekliško nošo. Morda bi v primerih, ko se pojavljajo v paru, lahko videli dečke, ker je nošnja dveh fibul bolj tipična za moško kot za žensko nošo.¹⁶⁷⁷ Drugo številno skupino (ok. 42 %) predstavljajo ženske in deklice, ki so nosile okrasje, dopolnjeno z nanožnicami in ovratnicami. Ovratnice so sicer značilne predvsem za otroke ali mladoletne osebe, vendar so jih imele tudi nekatere ženske.¹⁶⁷⁸ Predstavnice te skupine prav tako najdemo v vseh gomilah. Tretja skupina, ki razgrinja unikatne in hkrati najbogatejše oprave, je najmanjša (ok. 3 %), nosile pa so jih izbranke tako s Prelog (gom. 2, 13, VII, X) in Laščika (gom. V) kot tudi z Voselce (gom. 2, 6). Razen tega so ženski in otroški pokopi prepoznani še v skupini grobov, ki so od pridatkov vsebovali samo keramiko,¹⁶⁷⁹ ter v grobovih brez vsakršnih pridatkov.¹⁶⁸⁰

¹⁶⁷⁴ Dular/Tecco Hvala 2007, 249; Teržan 2008, 321.

¹⁶⁷⁵ Primerjaj npr. Connor 2004.

¹⁶⁷⁶ *Umetnost alpskih Ilirov in Venetov 1962*; Lucke/Frey 1962; Frey 1969; Bonfante 1981; Eibner 1981; ead. 1984; ead. 2004; ead. 2009; Huth 2003, Teržan 1997; ead. 1998; ead. 2001a; ead. 2001b; ead. 2004; ead. 2007b; ead. 2011b; Turk 2005; Dular J. 2008.

¹⁶⁷⁷ Glej tu poglavje 4.7 o fibulah.

¹⁶⁷⁸ Glej tu poglavje 4.8 o ovratnicah.

¹⁶⁷⁹ Otroška sta bila grobova 2/37, 13/140 (Tecco Hvala/Dular/Kocuvan 2004, 39, 74), ženski pa IV/14 (Angel 1968, 97).

¹⁶⁸⁰ Otroški je bil grob 13/149 (Tecco Hvala/Dular/Kocuvan 2004, 76), ženska pa V/24 in X/3 (Angel 1968, 78).

other members of the tumulus (V/19–20 and V/26a), while the men buried in Graves 2/1–2 and IV/32 at Preloge were each offered a helmet of presumed Negova type, both now lost.

Elite of horsemen is not the only indicator of a military hierarchy; the other is a wide variety of the male outfit, in which weapons appear in various combinations (fig. 45: B). Men without horses and armed only with axes and/or spears may have formed infantry units (fig. 55). However, such military stratification is not clearly witnessed in the Early Hallstatt period¹⁶⁷³ and the weapons, together with horses, probably represented primarily items of prestige (fig. 38). In the Late Hallstatt period, on the other hand, the number of armed members of communities increases considerably, while their equipment indicates ranking, the armament is more standardized, particularly when including the socketed axe that served as the distinguishing mark of the Dolenska warriors of the time. Based on the above, we may assume that the communities of Dolenska, at least occasionally, formed a military alliance or confederation,¹⁶⁷⁴ which would represent a new stage in social organization.¹⁶⁷⁵

An insight into the imagery of the people in those times can also be gained through the situla art. Details of figural scenes include individual elements that have pendants in the grave goods; it is therefore assumed that the visual narrative is based on every-day and festive events. Products of situla art show men as fishermen and ploughmen, practising cult (such as animal sacrifice), as hunters and, most often, as wrestlers, horsemen and warriors. The figural scenes also include inauguration of chieftains and transferral of authority. Studies dedicated to this topic showed that these scenes carry several meanings.¹⁶⁷⁶

DIFFERENTIATION OF WOMEN AND CHILDREN

Besides men, differentiation is noticeable also in the costume of women and children (fig. 136). The first group includes more than half the women and children buried at Magdalenska gora (ca. 55%) with rather poor costume, without anklets and torques. They can be detected in all the tumuli. The costume of this group most often includes fibulae as the only item, whereby fibulae are not indicative of the female or children's costume alone. Whenever they appear in pairs we might see burials of boys, since two fibulae more frequently formed part of the male costume.¹⁶⁷⁷

¹⁶⁷³ Teržan 1985.

¹⁶⁷⁴ Dular/Tecco Hvala 2007, 249; Teržan 2008, 321.

¹⁶⁷⁵ Cf., for example, Connor 2004.

¹⁶⁷⁶ *Umetnost alpskih Ilirov in Venetov 1962*; Lucke/Frey 1962; Frey 1969; Bonfante 1981; Eibner 1981; ead. 1984; ead. 2004; ead. 2009; Huth 2003, Teržan 1997; ead. 1998; ead. 2001a; ead. 2001b; ead. 2004; ead. 2007b; ead. 2011b; Turk 2005; Dular J. 2008.

¹⁶⁷⁷ See Chapter 4.7 on fibulae.

Fibule Fibulae	Zapestnice Bracelets	Nanožnice Anklets	Uhani Earrings	Ogrlice Necklaces	Ovratnice Torques	Laščik Gom. / Tum.		Preloge Gom. / Tum.							Voselca	Skupaj Total	
						1-12	V	2	IV	VI	VII	VIII	X	13			
■							3	3	1		3		1	8	1	20	
■	■			■		1	1	5	1		2		2	2	2	16	
	■			■			2	4	1				1	6		14	
	■						2	2	2	2	1		1	5		15	
■	■		■	■			1	4	1					4	1	11	
■			■	■				6	1				2	1	1	11	
■	■					2	1	2	1	1		2	2			11	
	■		■	■					1		2		1	3	1	8	
■			■	■				1	1	2	1			2		7	
■			■					1	2				1	3		7	
			■	■								1	2	4		7	
			■				1	1						4	1	7	
■	■	■		■			1	1		1	2		1	1		7	
■	■				■			4		2				1		7	
■	■		■	■		1		1			1			1	1	5	
■	■	■	■	■				1						2	1	4	
	■	■				1			1					2		4	
■	■			■	■							1	1		1	3	
	■			■	■								1	2		3	
■	■		■					1	1						1	3	
	■	■	■								1			1		2	
■	■	■	■	■	■			1		1						2	
■	■	■	■	■	■						1					1	
■	■	■	■	■	■			1								1	
■	■	■	■	■	■									1		1	
	■	■	■	■	■			1								1	
Scepter / Sceptre							1						1	3	2	7	
Au nakit / Au jewellery							2					1	1	1			5
Br posode / Br vessels							2			1				1	2		6

Sl. 136: Speker ženskih in otroških oprav po posameznih gomilah na Magdalenski gori
(n = število grobov z določeno vrsto ali kombinacijo pridatkov).

Fig. 136: Variants of the female and children's costume in individual tumuli
(n = number of graves with a particular combination of objects).

Razlike v noši so deloma kronološko pogojene in v precejšnji meri povezane z modnimi trendi, za katere so bile ženske bolj dovzetne kot moški. Obenem je žensko okrasje dokaj dober pokazatelj blagostanja in kriznih razmer, saj je od faze do faze opazno nihanje bogastva pridatkov v njihovih grobovih. Najbolj razkošne ženske oprave so znane iz druge in četrte faze razvoja magdalenskogorske skupnosti, razen tega so najprestižnejši ženski grobovi številnejši v največjih gomilah na Prelogah (2/a, 2/c, 2/n, 2/p, 2/11, 13/36, 13/97, 13/117), za katere predpostavljamo, da odražajo najmočnejša hišna gospodarstva. Hkrati pa ti dve gomili razkrivata najširši spekter oprav, iz česar sledi, da je med njihovimi pripadnicami obstajala hierarhija, ki je domnevno temeljila na različnih vlogah, starostnih razlikah in povezavah z moškimi člani (denimo kot matere, žene, hčere, neporočene sestre, snahe, pastorke itd. in kot služinčad).

The second group (ca. 42%) comprises women and girls who also wore anklets and torques. Torques are primarily characteristic of children or minors, thought they were also worn by some women.¹⁶⁷⁸ The representatives of this group can be found in all tumuli. The third group is that with unique and richest examples of costume, but it is also the smallest (3%). Examples of this group were recorded at Preloge (Tum. 2, 13, VII, X), Laščik (Tum. V) and Voselca (Tum. 2, 6). There are further burials of women and children to be identified within the group of graves with only pottery goods,¹⁶⁷⁹ as well as in graves without goods.¹⁶⁸⁰

¹⁶⁷⁸ See Chapter 4.8 on torques.

¹⁶⁷⁹ The excavator described Graves 2/37, 13/140 as those of children (Tecco Hvala/Dular/Kocuvan 2004, 39, 74), while Angel determined the human bone remains from Grave IV/14 as female (Angel 1968, 97).

¹⁶⁸⁰ Child's Grave 13/149 (Tecco Hvala/Dular/Kocuvan

Za tradicionalne družinsko-rodovno organizirane družbe so na splošno značilni zelo zapleteni in kompleksni sorodstveni sistemi, v katerih imajo poročne strategije pomembno vlogo. Osredotočene so na ohranjanje simbolnega in materialnega "kapitala" posameznega rodu in ne izključujejo porok s paralelnimi sestričnami, polsestrami, nečakinjami, vdovami po bratih, prav tako ne elitnih porok s tujkami kot garant dobrih in trdnjših odnosov med različnimi skupnostmi.¹⁶⁸¹ Primeri endogamnih in elitnih porok so razen iz modernih etnosocioloških študij znani tudi iz grške antične zgodovine.¹⁶⁸² Morda bi lahko domnevali, da so se nekateri pripadniki magdalenskogorske skupnosti prav tako poročali s tujkami, kar bi kazali neobičajni ženski pokopi, ki imajo v grobnem ritualu in/ali pridatkih najboljše primerjave v drugih kulturnih okoljih (npr. 2/37, 13/24, 13/163 s Prelog in 6/1 z Voselce). Na drugi strani pa bi centralne grobove dozdevno skupnih prednikov lahko posredno postavljali v zvezo z endogamnimi porokami, kajti ti so dejansko možni le v primeru krvnega sorodstva.¹⁶⁸³

O vlogi žensk v življenju dolenske skupnosti lahko sklepamo po nekaterih značilnih pridatkih v njihovih grobovih, kot so vijčki in šivanke, ki govorijo, da je bila tekstilna dejavnost v njihovi domeni.¹⁶⁸⁴ Mestoma so se ohranili celo skromni ostanki ali odtisi tkanin, analize le-teh pa so pokazale, da je šlo za več vrst tkanja in tudi za bolj zapletene načine.¹⁶⁸⁵ Sestave prediva oz. vlaken v večini primerov ni bilo mogoče določiti, le na eni izmed pasnih spon v muzeju na Dunaju so bili ugotovljeni ostanki volne,¹⁶⁸⁶ na drugi iz Peabodyjevega muzeja pa je Segal Brandford ugotovila dve vrsti tkanin, eno na zgornji in eno na spodnji strani pasne spone, iz česar je moč predpostavljati, da je šlo za zgornje in spodnje oblačilo.¹⁶⁸⁷ Oblačila magdalenskogorskih izbrank 2/a, 2/n in 13/97, 13/117 so bila domnevno pošita še z množico drobnih steklenih perlic modre, bele in rumene barve ter z bronastimi okraski, kajti v grobovih se je takšno okrasje razprostiralo od nog do glav pokojnic; te oprave iz certoške stopnje pa so spadale med najlepše na Dolenskem.

Da so ženske nosile obleke, ki so segale do goleni, povrh pa ogrinjala čez glavo, kažejo upodobitve na situlskih spomenikih,¹⁶⁸⁸ ki simbolizirajo vlogo žensk v več pomenih. Na situlskih prizorih se pojavljajo kot tkalke ali predilke, tkalni in predilni pripomočki pa imajo tudi apotropejski značaj, povezujejo jih z napovedovanjem

¹⁶⁸¹ Glej npr. Radcliffe-Brown 1994; Bourdieu 2002.

¹⁶⁸² Glej npr. Humphreys 1994, 24 ss, 110, 117; Osborne 2004, 41 ss; Seaford 2004, 56 ss.

¹⁶⁸³ Glej npr. Radcliffe-Brown 1994.

¹⁶⁸⁴ Glej tu poglavje 4.12 o drugih pridatkih.

¹⁶⁸⁵ Segal Brandford 1978, 301 ss; Bender Jørgensen 2005, 133 ss, Kat. št. 98–100; Grömer/Stöllner 2009, 153.

¹⁶⁸⁶ Bender Jørgensen 2005, 144, Kat. št. 98.

¹⁶⁸⁷ Segal Brandford 1978, 308.

¹⁶⁸⁸ Turk 2005, sl. 2, 32–35, 37, 41, 42, 52, 53, 59, 75, s citirano literaturo.

The differences in costume are partly chronologically conditioned and closely tied to fashion trends, to which women were more susceptible than men. At the same time, female adornments represent a good indicator of the general prosperity or of times of crisis, since they show, together with other goods, visible oscillations from phase to phase. The female costume was most rich in Phases II and IV of the development of the Magdalenska gora community. The prestigious female graves are most numerous in Tumuli 2 and 13 at Preloge (2/a, 2/c, 2/n, 2/p, 2/11, 13/36, 13/97, 13/117), which presumably represent the most powerful households. The two tumuli also revealed the widest variety of costume, which may point to a hierarchy among the female members, based on different roles, age difference and connections with the male members (for example as mothers, unmarried sisters, wives, daughters, daughters-in-law, stepdaughters and as servants).

The societies with a traditional organization into families and clans are generally characterized by very complex kinship system, in which marriage strategies play an important role. Their aim was preservation of the symbolic and material "capital" of a clan and they do not exclude marriage with parallel cousins, half-sisters, nieces, brothers' widows, nor elite marriage with foreign women as a guarantee of good and strong partnerships between different communities.¹⁶⁸¹ Examples of endogamous and elite marriage are known, apart from modern ethno-sociological studies, also from ancient Greek history.¹⁶⁸² We may suppose that some members of the Magdalenska gora community also married foreign women. The latter may be detected in unusual female burials with best analogies in burial rite and/or grave goods in other cultural milieus (for example Graves 2/37, 13/24, 13/163 from Preloge and 6/1 from Voselca). On the other hand, the central graves of presumed common ancestors could indirectly be brought into connection with endogamous marriage, since these are only possible in the case of consanguinity.¹⁶⁸³

The role of women in the life of the Dolenska community can be inferred from specific goods found in their graves, such as spindle whorls and needles. The latter show that textile production was in the woman's domain.¹⁶⁸⁴ Sometimes small pieces or imprints of textile have been preserved on objects from graves. Their analysis has shown both finger- and loom-woven structure as well as different techniques of weaving.¹⁶⁸⁵

2004, 76) and female Graves V/24 and X/3 (Angel 1968, 78).

¹⁶⁸¹ See, for example, Radcliffe-Brown 1994 (1952); Bourdieu 2002 (1980).

¹⁶⁸² See, for example, Humphreys 1994, 24 ff, 110, 117; Osborne 2004, 41 ff; Seaford 2004, 56 ff.

¹⁶⁸³ See, for example, Radcliffe-Brown 1994 (1952).

¹⁶⁸⁴ See Chapter 4.12 on other grave goods.

¹⁶⁸⁵ Segal Brandford 1978, 301 ff; Bender Jørgensen 2005, 133 ff, Cat. Nos. 98–100; Grömer/Stöllner 2009, 153.

usode, odganjanjem urokov ali kot pritlikino gospodaric domačega ognjišča (*dominae*).¹⁶⁸⁹ Iz likovne pripovedi je prav tako moč razbrati, da so ženske sodelovale v obrednih slovesnostih, torej tudi v javnem življenju, morda kot svečenice. Temu pritrjujejo sceptri, ritualno posodje (*sl. 131: a–d, f, g*) in živalske kosti med pridatki v grobovih izbrank, pri čemer bode v oči, da so med njimi deklice, ki so umrle v rosnih mladosti (npr. Preloge, gr. 2/c, 2/11, 2/37, 13/97; Voselca, gr. 2/6, 6/1). Na vprašanja o vzroku njihove prezgodnje smrti, kakšna vloga jim je bila namenjena, ali so bile morebiti žrtvovane za spremstvo posvetnemu gospodarju ali kakemu božanstvu v dobro skupnosti, je kajpada težko odgovoriti.

KULTNO-RELIGIOZNA SFERA

Skupni kultni, verovanja in slavja so zagotovo predstavljali pomembno družbeno vezivo oz. kohezivno silo na simbolni ravni. Indicem čaščenja skupnih prednikov in herojev je bilo že namenjenih nekaj besed. S *kultom prednikov*, ki je na splošno značilen za družinsko-rodovne skupnosti, se je v družbah brez pisave ohranjal genealoški spomin, njegovo manifestacijo pa bi na Dolenjskem lahko videli v najstarejših centralnih grobovih v gomilah z več pokopi. Drugačen memorialni kult predstavlja akt heroiziranja oz. povzdigovanja osebnosti, ki ga je moč slutiti v osrednjih grobovih iz mlajših faz, v katerih so bili pokopani izbranci, ki so si kolektivni spomin verjetno zaslužili zaradi njihovih posebnih odlik, vrlin, dejanj in zaslug za vso skupnost. *Kult herojev* se je nemara v tej sredini širše razmahnil pod vplivom grško-etruske ideologije, kar bi lahko domnevali po pridatkih v grobovih teh častivrednih mož. Dragoceni servisi posodja za banket in figuralne upodobitve (*sl. 130*), ki govorijo v skupnem simbolnem jeziku, razumljivem ljudem od Etrurije do Podonavja, so najzgovornejše priče akulturacije mediteranskih idealov. Med žanrskimi prizori situlske umetnosti se pojavljajo dvoboj atletov, igre, neke vrste simpozij, lov, pa tudi fantastični krilati stvori in eksotične živali, ki odražajo zbliževanje s kulturnimi obrasci in mitologijo stare Grčije oz. vzhodnega Sredozemlja.¹⁶⁹⁰

Prebivalci Dolenjske so v starejši železni dobi dozdavno častili še razna stara božanstva. O prežitkih žarnogrobišnega verovanja oz. starodavnega čaščenja *sonca* govore simboli v obliki koncentričnih krožcev (t. i. sončna kolesa) in rac oz. vodnih ptic, ki krasijo razne predmete

In most cases, the fibre could not be determined. An exception is one of the belt clasps held in the museum in Vienna, which revealed remains of wool.¹⁶⁸⁶ Another exception is a belt clasp kept in the Peabody Museum, where Segal Brandford established two different kinds of textile, one on the upper and the other on the bottom side; this indicates a dress, shirt or a blouse with an outer garment worn over it.¹⁶⁸⁷ Select women from Magdalenska gora buried in Graves 2/a, 2/n and 13/97, 13/117 were presumably adorned with a multitude of small glass beads of blue, white and yellow colours, as well as bronze trimmings, sewn onto their garments. These costumes from the Certosa phase were among the most beautiful ones in Dolenjska.

Representations on objects of situla art show women wearing dresses that reach down to their knees and over this cloaks covering their heads.¹⁶⁸⁸ These representations symbolized the role of women from several aspects. Women appear as weavers or spinners, whereby the weaving and spinning implements also carry an apotropaic significance; they are tied to augury, removal of spells or as attributes of the mistress of the homestead (*dominae*).¹⁶⁸⁹ The visual narratives also reveal women participating in ritual festivities, i.e. in public life, possibly as priestesses. This indication is supported by sceptres, ritual vessels (*fig. 131: a–d, f, g*) and animal bones found among the goods in the graves of select women. Among the latter we should particularly mention girls that died at an early age (for example in Graves 2/c, 2/11, 2/37, 13/97 at Preloge and Graves 2/6, 6/1 at Voselca). The cause of their premature death remains unknown, as does the role they played within the community and whether they may have been sacrificed to accompany his master into the afterlife or to a divinity for the benefit of the community.

CULT AND RELIGIOUS SPHERE

Common cults, beliefs and festivities certainly represented an important social bond and a cohesive force of a community on a symbolic level. The indications for veneration of common ancestors and heroes have already been discussed above. The *ancestor cult*, which is generally characteristic of the family-kin communities, has served in pre-literate societies to preserve the genealogical memory, while its manifestation in Dolenjska could be seen in the earliest central graves of tumuli that contained more than one burial. A different memorial cult can be seen in the heroization or glorification of

¹⁶⁸⁹ Eibner 1984; ead. 200–2001; Teržan 1996b; ead. 2004b; Amann 2000, 131 ss; Rallo 2000; D'Ercole 2000a; Primas 2007; Fath/Glunz-Hüsken 2011.

¹⁶⁹⁰ *Umetnost alpskih Ilirov in Venetov* 1962; Lucke/Frey 1962; Frey 1969; Bonfante 1981; Eibner 1981; ead. 1984; ead. 2004; ead. 2009; Huth 2003, Teržan 1997; ead. 1998; ead. 2001a; ead. 2001b; ead. 2004; ead. 2007b; ead. 2012; Turk 2005; Egg/Lehnert 2011; Lazar 2011.

¹⁶⁸⁶ Bender Jørgensen 2005, 144, Cat. No. 98.

¹⁶⁸⁷ Segal Brandford 1978, 308.

¹⁶⁸⁸ Turk 2005, Figs. 2, 32–35, 37, 41, 42, 52, 53, 59, 75, with further references.

¹⁶⁸⁹ Eibner 1984; ead. 200–2001; Teržan 1996b; ead. 2004b; Amann 2000, 131 ff; Rallo 2000; D'Ercole 2000a; Primas 2007; Fath/Glunz-Hüsken 2011.

iz halštatskega obdobja.¹⁶⁹¹ Na Magdalenski gori so bile z njimi okrašene izgubljena moška pasna spona iz groba 13/69 in bronaste situle iz grobov V/29, 2/a in 13/119 s Prelog (sl. 131: a), ponekod drugod se t. i. sončna kolesa pojavljajo kot obeski na sceprih; k tovrstnim simbolnim izrazom lahko prištejemo še glinasto trodelno posodico v obliki račk, ki jo je imela deklica v grobu 2/6 z Voselce (sl. 131: f). Čaščenje sonca v novi preobleki bi lahko videli tudi v fibuli v obliki trige (sl. 99: 2), ki morebiti upodablja Helijev voz oz. zgodbo o Faetontu, nosila pa jo je deklica, pokopana v grobu 2/c na Prelogah. Odsev tega verovanja se nemara zrcali v jantarju, ki je bil zelo priljubljen med pripadnicami dolenske skupnosti.¹⁶⁹²

Vodne ptice – kot simbol vlažnosti oz. mokrote nasproti soncu – so atribut prastarega ženskega božanstva, ki pooseblja rodnost in naravni cikel.¹⁶⁹³ Tudi razne druge živali, predvsem jelenjad, srnjad, koze, kozorogi, ovni ipd., se povezujejo z ženskim božanstvom, ki jo iz antičnih virov poznamo kot gospodarico živali (*potnia theron*). Podobne lastnosti in attribute ima v klasični dobi grška Artemida, ki so jo častili v mnogih svetiščih, kjer so ji te živali tudi žrtvovali. Z njo so povezane razne legende iz grškega bajeslovja, kot npr. o Ifigeniji, ki naj bi bila žrtvovana v zameno za ugodno plovbo proti Troji, a je njeno žrtev v zadnjem hipu nadomestila srna oz. košuta. Ali pa zgodba o mladem Atenčanu, ki je ubil svetega medveda in s tem raztogotil Artemido, ki je nad Atene poslala kugo, njen bes pa je pomirila šele zaobljuba, da bodo za njene misterije izbrane majhne deklice, po neki drugi verziji pa naj bi zahtevala žrtvovanje deklice.¹⁶⁹⁴ Morda je bila podobna usoda namenjena nekaterim deklicam iz magdalenskogorske skupnosti, ki so bile pokopane v bogatih opravah s prestižnimi predmeti in scepri, kajti kult Artemide oziroma njej sorodnega božanstva je bil domnevno razširjen tudi v severnojadranskem zaledju.¹⁶⁹⁵

Prav tako je v tem prostoru iz antičnih virov poznan kult Diomeda pri izviru Timava, ki naj bi mu bil žrtvovan bel konj. Konji so povezani tako z božanskim svetom, saj naj bi se z njimi vozili domala vsi olimpski bogovi, kakor tudi s tuzemskim (predvsem moškim) svetom, kjer so predstavljali gospodarsko dejavnost (vzrejo), apoteozo herojev ali pa družbeni status oz. sloj.¹⁶⁹⁶

¹⁶⁹¹ Kossack 1954a; id. 1999; Teržan 2003, 70 s; Fossati 2006, 36.

¹⁶⁹² Glej poglavja 4.4.2 o ornamentiki na pasnih sponah, 4.7.9 o figuralnih fibulah, 4.8.2 o jantarju in 4.11.1 o sceprih.

¹⁶⁹³ Bevan 1986; Gimbutas 1989, 109 ss; Velušček 2007; Teržan 1990a, 111 s; ead. 1995c; ead. 2001b; ead. 2003; ead. 2005; ead. 2011a, 241 ss; Mastrocinque 1987.

¹⁶⁹⁴ Bevan 1986, 18 s, 101 ss, 170 s.

¹⁶⁹⁵ Mastrocinque 1987, 21 ss; Šašel Kos 1999, 13 ss.

¹⁶⁹⁶ Bevan 1986, 194 ss, 322 s; Mastrocinque 1987, 79 ss; Katičić 1989; Grilli 1991; Kirigin/Čače 1998; Prosdocimi 2003; Gambacurta 2003; Fiore/Salerno/Tagliacozzo 2003; Marinetti 2003; Maggiani 2003; Šašel Kos 1999, 18 s; ead. 2005, 115 ss; Teržan 2011b.

personalities discernible in the central graves from later phases; these select individuals probably earned to enter the collective memory through merit, virtue, heroic acts and deeds performed for the benefit of the entire community. The *hero cult* probably became widely practised in Dolensjska with the spread of the Graeco-Etruscan ideology, which can be supposed from the goods in the graves of honourable men. The precious sets of banqueting vessels and figural representations (fig. 130), which speak in a common symbolic language understandable to people from Etruria to the Danube basin, stand as the most eloquent testimonies of the acculturation of the Mediterranean ideals. Genre scenes of the situla art show athletic contests, games, sort of a symposium, hunting, as well as fantastic winged creatures and exotic animals, which bridge the differences between Dolensjska and the cultural norms and mythology of ancient Greece and the eastern Mediterranean.¹⁶⁹⁰

The inhabitants of Dolensjska are believed also to have venerated various old divinities. Relicts of the Urnfield culture beliefs or the ancient *worship of the sun* can be seen in the symbols shaped as concentric circles (so-called sun-wheels) and ducks or water birds that adorn various artefacts from the Hallstatt period.¹⁶⁹¹ At Magdalenska gora, these motifs adorned the now lost belt clasp from male Grave 13/69 and the bronze situlae from Graves V/29, 2/a, 13/119 at Preloge (fig. 131: a). The so-called sun-wheels can also appear as pendants on scepres. These symbolic expressions can further be added a tripartite clay vessel in the shape of ducks, which was found in girl's Grave 2/6 at Voselca (fig. 131 f). Veneration of the sun in a different form can also be seen in the fibula shaped into a three-horse chariot or triga (fig. 99: 2), possibly representing Helios' chariot or the legend of Phaeton; it was found in girl's Grave 2/c at Preloge. Veneration of the sun may further be perceived in the use of amber, which was very popular among the female members of the Dolensjska communities.¹⁶⁹²

Water birds – symbols of moisture in opposition to the sun – are attributes of an ancient female divinity that personifies fertility and the natural cycle.¹⁶⁹³ Various other animals as well, primarily roe and red deer, goats, steinbocks, rams and others, are connected with a female divinity, known from the ancient sources as the Mistress of the Animals or *potnia theron*. In the Greek Classical

¹⁶⁹⁰ *Umetnost alpskih Ilirov in Venetov* 1962; Lucke/Frey 1962; Frey 1969; Bonfante 1981; Eibner 1981; ead. 1984; ead. 2004; ead. 2009; Huth 2003, Teržan 1997; ead. 1998; ead. 2001a; ead. 2001b; ead. 2004; ead. 2007b; ead. 2012; Turk 2005; Egg/Lehnert 2011; Lazar 2011.

¹⁶⁹¹ Kossack 1954a; id. 1999; Teržan 2003, 70 f; Fossati 2006, 36.

¹⁶⁹² See Chapters 4.4.2 on decoration on belt clasps, 4.7.9 on figural fibulae, 4.8.2 on amber and 4.11.1 on scepres.

¹⁶⁹³ Bevan 1986; Gimbutas 1989, 109 ff; Velušček 2007; Teržan 1990a, 111 f; ead. 1995c; ead. 2001b; ead. 2003; ead. 2005; ead. 2011a, 241 ff; Mastrocinque 1987.

Na Magdalenski gori je bilo odkritih največ pokopov konjev v jugovzhodnih Alpah,¹⁶⁹⁷ v nekaterih ženskih grobovih pa so bili najdeni kostni in roževinasti ostanki jelenjadi, srnjadi in drobnice ali predmeti z upodobitvami ovnovih glav, v katerih bi lahko slutili čaščenje gospodarice živali.¹⁶⁹⁸ Vse te živali so pogost motiv v situlski umetnosti, tako tudi rastlinje v rasti in razcvetu, ki poleg prizorov oranja, (božanskega) lova, pa tudi erotične združitve nemara simbolizirajo kult plodnosti in čas, ko se začneja nov naravni cikel.

Za konec se ustavimo še pri vprašanju, kakšno stopnjo družbenega razvoja je dosegla magdalenskogorska in nasploh dolenska skupnost oz. kakšno obliko družbenopolitične organizacije lahko predpostavljamo na osnovi arheoloških indecev. Glede na obrise teritorialne entitete in kulturne identitete, razvejane gospodarske dejavnosti in menjave, vojaške formacije, družbene razslojenosti in hierarhije bi jih vsaj v zametkih lahko primerjali s procesi v Padski nižini in alpskem svetu,¹⁶⁹⁹ ki pa se niso razvili v enaki meri.

V dolenski regiji se niti v poselitveni sliki niti v strukturi grobišč ali grobnih pridakih ne kaže odločilna prevlada enega kraja, ene rodovine ali ene avtoritete, da bi lahko govorili o hegemoniji enega centra in dinastični obliki politične oblasti, kar bi upravičevalo rabo oznak, kot so knezi, kneginje, princeze, aristokracija.¹⁷⁰⁰ Elita ni bila ostro ločena od ljudstva (niti družbeno niti prostorsko), vodilni predstavniki so bili pokopani skupaj z drugimi prebivalci, tako kakor so verjetno tudi živeli. Magdalenskogorsko naselbino sicer sestavljata nekakšna "akropola" in "spodnje mesto" (sl. 137), pa tudi druga središča imajo ločene predele z notranjimi zidovi, vendar stanje raziskav za zdaj ne omogoča podrobnejšega uvida v notranjo strukturiranost in prepoznavanje rezidenčnih predelov ali javnih zgradb. Razen gomil in obzidij tudi ne poznamo drugih monumentalnih gradenj, prav tako ne skupnih svetišč ali ceremonialnih središč, mitičnih ustanoviteljev oz. zavetnikov skupnosti, niti pisnih sporočil (z izjemo nekaj votivnih napisov) ali denarnih enot (razen ražnjeve kot morebitnega predmonetarne sredstva), ki bi kazali na zametke "primitivne", "zgodnje" ali "arhajske" države na tem območju.

Po teoretskih modelih družbenega razvoja dolensko halštatsko skupnost še najlažje umestimo v cikel

period, similar characteristics and attributes are found with Artemis, venerated in numerous sanctuaries where the above-mentioned animals were sacrificed. Connected with Artemis are various legends from the Greek mythology, for example the legend of Iphigenia, who was to be sacrificed to ensure a safe journey towards Troy, but was replaced at the last moment by a deer. There is also the story of a young Athenian who had killed a sacred bear and thus enraged Artemis, who sent plague over Athens and was only appeased by a promise of young girls serving in her mysteries; another version of this story even stated that Artemis demanded the sacrifice of a young girl.¹⁶⁹⁴ A similar fate may have befallen some of the girls from the Magdalenska gora community, buried in a rich costume with items of prestige and with sceptres, since the cult of Artemis or related divinities is believed to have been present in the hinterland of the northern Adriatic as well.¹⁶⁹⁵

Also present in this area was the cult of Diomedes near the springs of the Timavus, known from ancient sources, to which a white horse was sacrificed. Horses are thus tied to both the divine, carrying almost all the Olympian Gods, and the earthly, primarily male sphere, where they represented either an economic activity (breeding), apotheosis of heroes or social status.¹⁶⁹⁶

Magdalenska gora revealed the highest number of horse burials in the south-eastern Alps.¹⁶⁹⁷ Some female graves, on the other hand, revealed bone remains of red and roe deer as well as of caprovids or objects with representations of ram's heads, all of which might conceal the veneration of the mistress of the animals.¹⁶⁹⁸ The enumerated animals are also frequent motifs in the situla art, where they appear side by side with plants growing and blooming, as well as scenes of ploughing, (divine) hunting and erotic union (*symplegma*) that may symbolize a fertility cult and the beginning of a new natural cycle.

The discussion concludes with the question of the degree of social development achieved by Magdalenska gora and the Dolenska community or, in other words, what form of socio-political organization can be supposed on the basis of archaeological data. Considering the territorial entity and cultural identity, diversity of economic activity and trade, military formation, social stratification and hierarchy outlined above, it could be

¹⁶⁹⁴ Bevan 1986, 18 f, 101 ff, 170 f.

¹⁶⁹⁵ Mastocinque 1987, 21 ff; Šašel Kos 1999, 13 ff.

¹⁶⁹⁶ Bevan 1986, 194 ff, 322 f; Mastocinque 1987, 79 ff; Katičić 1989; Grilli 1991; Kirigin/Čače 1998; Prosdociami 2003; Gambacurta 2003; Fiore/Salerno/Tagliacozzo 2003; Marinetti 2003; Maggiani 2003; Šašel Kos 1999, 18 f; *ead.* 2005, 115 ff; Teržan 2011b.

¹⁶⁹⁷ Dular 2007b.

¹⁶⁹⁸ See Chapter 3.2.4 on animal remains in the funerary cult, fig. 36.

¹⁶⁹⁷ Dular 2007b.

¹⁶⁹⁸ Glej tu poglavje 3.2.4 o živalskih ostankih v grobnem kultu, sl. 36.

¹⁶⁹⁹ Bonamici 2000; Manichetti 2000; Gleircher 2001; Guidi 2004; Sassatelli 2004; ter prispevki v: Krausse (ur.) 2010.

¹⁷⁰⁰ Dular/Tecco Hvala 2007, 247 ss; Dular J. 2008, 429; Teržanova zagovarja nekoliko drugačno mnenje: Teržan 2008, 270 ss.

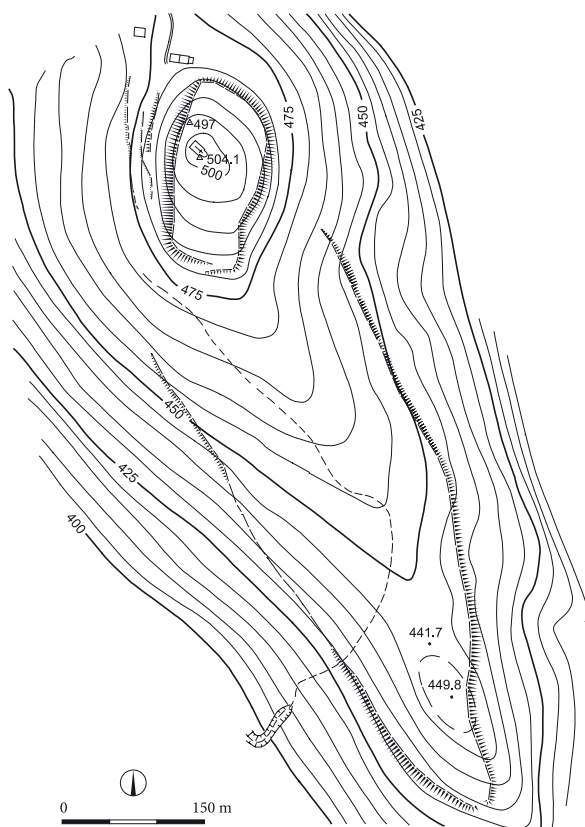

Sl. 137: "Akropola" in "spodnje mesto" na Magdalenski gori (po Tecco Hvala/Dular/Kocuvan 2004, Pril. 1).

Fig. 137: "Acropolis" and lower settlement at Magdalenska gora (after Tecco Hvala/Dular/Kocuvan 2004, Beil. 1).

poglavarstev (*chiefdom*),¹⁷⁰¹ ki je z vojaškega vidika in vidika kulturne in gospodarske integracije naredila korak v smeri razvitejše politično-teritorialne organizacije, vendar rodovnih pravic dozdevno ni prenesla na mestno državo, kar bi neizogibno pomenilo spremembo vrednot in narave družbenih odnosov.¹⁷⁰² Zatorej se zdi še najprimerneje govoriti o družinsko-rodovni strukturi in eliti ter poglavarjih srenj.

¹⁷⁰¹ Fried 1967; Renfrew et al. (ur.) 1982; Bintliff (ur.) 1984; Breuer 1990; Earle (ur.) 1991; Arnold/Gibson (ur.) 1995; Diamond 1999; Krausse (ur.) 2010 (najnovejši pregled konceptov).

¹⁷⁰² Predpostavlja se, da je do razpada rodovne organizacije prišlo z grško in rimsko državo: Radcliffe-Brown 1994, 56; Arnold/Gibson 1995, 8. O odnosu med *oikos* in *polis* je Sarah C. Humphreys (1993, 1 ss) zapisala: "[...] Plato thought that a perfect city could only be created by abolishing the private household and family [...]", in da Platon zagotovo ni bil edini Atenec, ki je čutil nasprotje med vrednotami *polis* in *oikos* oz. med mestom in družino.

compared, at least in the bud, with the processes unfolding in the Po Plain and the Alpine world,¹⁶⁹⁹ though it did not develop to the same degree.

The Dolenjska region does not show the dominance of a single centre, a clan or authority neither in the settlement pattern nor in the structure of cemeteries and grave goods. The absence of hegemony of a single centre and a dynastic form of government also precludes the use of terms such as prince, princess and aristocracy.¹⁷⁰⁰ The elite was not isolated, neither socially nor spatially; the leading representatives were buried together with other inhabitants and probably lived in the same way. The settlement at Magdalenska gora does appear to be composed of a sort of an acropolis and a lower settlement (fig. 137). Other settlements as well show internal division with dividing walls, though the current state of research does not allow a more detailed insight into the inner structure and identification of residential areas or public buildings. With the exception of tumuli and defence walls, there is also no evidence of other monumental structures, of common sanctuaries or ceremonial centres, mythical founders or patrons of communities, written documents (with the exception of a few votive inscriptions), or monetary units (with the exception of a few spits as a possible pre-monetary means of payment), which would indicate the beginnings of a "primitive", "early" or "archaic" state in the region.

Considering the theoretic models of social development,¹⁷⁰¹ the Dolenjska Hallstatt community could best fit the cycle of chiefdoms. From the military aspect as well as the aspect of cultural and economic integration, we may discern its pace towards a more developed form of political and territorial organization, though it did not appear to have transferred the rights of a clan to a those of a city state, which would unavoidably lead to a change in the value system and in the nature of social relationships.¹⁷⁰² For that reason, it seems most justifiable to use the terms family-kin structure, elite and community chieftains when referring to the Magdalenska gora community and Dolenjska in general.

¹⁶⁹⁹ Bonamici 2000; Manichetti 2000; Gleircher 2001; Guidi 2004; Sassatelli 2004; and treatises in: Krausse (ed.) 2010.

¹⁷⁰⁰ Dular/Tecco Hvala 2007, 247 ff; Dular J. 2008, 429; Teržan voiced a different opinion: Teržan 2008, 270 ff.

¹⁷⁰¹ Fried 1967; Renfrew et al. (eds.) 1982; Bintliff (ed.) 1984; Breuer 1990; Earle (ed.) 1991; Arnold/Gibson (eds.) 1995; Diamond 1999; Krausse (ed.) 2010 (recent overview of theoretic concepts).

¹⁷⁰² A generally adopted view is that the decay of the family-kin based organization was brought about by the Greek and Roman state: Radcliffe-Brown 1994, 56; Arnold/Gibson 1995, 8. On the relationship between *oikos* and *polis*, Sarah C. Humphreys (1993, 1 ff) wrote that, "[...] Plato thought that a perfect city could only be created by abolishing the private household and family [...]"; and that Plato was certainly not the only Athenian to feel the conflict between the values of the *polis* and the *oikos*, i.e. between the values of the city and the family.

7 LITERATURA

7 BIBLIOGRAPHY

- ADAM, A.-M. 1996, *Le fibule di tipo celtico nel Trentino*. – Patrimonio storico e artistico del Trentino 19.
- AIGNER-FORESTI, L. (ur. / ed.) 1992, *Etrusker nördlich von Etrurien. Etruskische Präsenz in Norditalien und nördlich der Alpen sowie ihre Einflüsse auf die einheimischen Kulturen*. Akten des Symposions von Wien-Schloß Neuwaldegg, 2.–5. Oktober 1989. – Österreichische Akademie der Wissenschaften, Philosophisch-historische Klasse, Sitzungsberichte 589.
- ALMARGO-GORBEA, M. (ur. / ed.) 1996, *Archäologische Forschungen zum Kultgeschehen in der jüngeren Bronzezeit und frühen Eisenzeit Alteuropas*. Ergebnisse eines Kolloquiums in Regensburg, 4.–7. Oktober 1993. – Regensburger Beiträge zur Prähistorischen Archäologie 2.
- ALVINO, G. 1992, Nuovi apporti per una conoscenza delle sepolture a tumulo: l'area cicolana. – V / In: M. Dardari (ur. / ed.), *La civiltà picena nelle Marche, Studi in onore di Giovanni Annibaldi*, Ancona, 10–13 luglio 1988, Ripatransone, 255–263.
- AMANN, P. 2000, *Die Etruskerin. Geschlechterverhältnis und Stellung der Frau im frühen Etrurien (9.–5. Jh. v. Chr.)*. – Archäologische Forschungen 5.
- ANGEL, J. L. 1968, Human skeletal remains from Slovenia. – V / In: *Mecklenburg Collection Part 1*, American School of Prehistoric Research, Bulletin 25, 73–108.
- ARHEOLOGIJA srednego Dona v skifskuju èpohu 2009. Trudy Donskoj arheologičeskoj èkspedicii IA RAN, 2004–2008. – Moskva.
- ARNOLD, B., D. B. GIBSON (ur. / eds.) 1995, *Celtic chiefdom, Celtic state. The evolution of complex social systems in prehistoric Europe*. – Cambridge.
- BAITINGER, H. 2011, *Waffenweihungen in griechischen Heiligtümern*. – Monographien des Römisch-Germanischen Zentralmuseums 94.
- BARTH, F. E. 1969, *Die hallstattzeitlichen Grabhügel im Bereiche des Kutscher bei Podsemel (Slowenien)*. – Antiquitas Reihe 3, Band 5.
- BARTH, F. E. 1999, Zu den im Situlenstil verzierten Gürtelblechen aus Brezje, Slowenien. – *Archäologisches Korrespondenzblatt* 29/1, 57–59.
- BATOVIĆ, Š. 1955, Nekoliko ilirskih antropomorfnih figura iz sjeverne Dalmacije (Einige illyrische anthropomorphe Figuren aus Norddalmatien). – *Arheološki vestnik* 6, 233–246.
- BATOVIĆ, Š. 1987, Liburnska grupa. – V / In: *Praistorija jugoslavenskih zemalja* 5, Sarajevo, 339–390.
- BECK, C. W., J. BOUZEK, D. DRESLEROVÁ (ur. / eds.) 1993, *Amber in archaeology*. Proceedings of the second international conference on amber in archaeology, Liblice 1990. – Praha.
- BEINHAEUER, K. W. 1985, *Untersuchungen zu den eisenzeitlichen Bestattungsplätzen von Novilara (Provinz Pésaro und Urbino, Italien)*. *Archäologie – Anthropologie – Demographie; Methoden und Modelle*. – Frankfurt am Main.
- BEITRÄGE zur Archäozoologie und Prähistorischen Anthropologie 1994, 8. Arbeitstreffen der Osteologen, Konstanz 1993. – Forschungen und Berichte zur Vor- und Frühgeschichte in Baden-Württemberg 53.
- BELLINTANI, P. 1997, Frattesina: l'ambra e la produzione vitrea nel contesto delle relazioni transalpine. – V / In: F. Marzatico, L. Endrizzi (ur. / eds.), *Ori delle Alpi*, Trento, 117–129.
- BELLINTANI, P. 2004, Ambre del II millennio a.C. in Italia. – V / In: F. Marzatico, P. Gleirscher (ur. / eds.), *Guerrigieri, principi ed eroi fra il Danubio e il Po dalla Preistoria all'Alto Medioevo*, Trento, 201–207.
- BENDER JØRGENSEN, L. 2005, Hallstatt and La Tène textiles from archives of Central Europe. – V / In: P. Bichler et al. (ur. / eds.), *Hallstatt textiles. Technical analysis, scientific investigation and experiment on Iron Age textiles*, BAR. International series 1351, 133–150.
- BERGONZI, G. 1981, L'area a Sud-Est delle Alpi e l'Italia del Nord intorno al V secolo A.C. – V / In: *Studi di protoistoria adriatica* 1, Quaderni di cultura materiale 2, 9–65.
- BERGONZI, G. 1984, Ceramica daunia nell'alto Adriatico. – V / In: *Preistoria del Caput Adriae*. Convegno di studi, Trieste, 19–20 novembre 1983, Udine, 177–188.
- BERGONZI, G. 1992, Etruria – Piceno – Caput Adriae: guerra e aristocrazia nell'età del ferro. – V / In: M. Dardari (ur. / ed.), *La civiltà picena nelle Marche, Studi in onore di Giovanni Annibaldi*, Ancona, 10–13 luglio 1988, Ripatransone, 60–88.
- BEVAN, E. 1986, *Representations of Animals in Sanctuaries of Artemis and other Olympian Deities*. – BAR. International series 315.
- BIANCHI BANDINELLI, R., A. GIULIANO 2000, *Etruschi e Italici prima del dominio di Roma*. – Milano.
- BINTLIFF, J. L. (ur. / ed.) 1984, *European Social Evolution. Archaeological Perspectives*. – Bradford.
- BLEČIĆ, M. 2007, Reflections of Picens Impact in the Kvarner Bay. – V / In: M. Guštin et al. (ur. / eds.), *Piceni ed Europa*, *Archeologia di frontiera* 6, 109–122.

- BÖKÖNYI, S. 1968, Data on Iron Age horses of Central and Eastern Europe. – V / In: *Mecklenburg Collection Part 1*, American School of Prehistoric Research, Bulletin 25, 1–71.
- BÖKÖNYI, S. 1993, *Pferdedomestikation, Haustierhaltung und Ernährung. Archäozoologische Beiträge zu historisch-ethnologischen Problemen.* – *Archaeolingua*, Series Minor 3.
- BÖKÖNYI, S. 1994, Analiza živalskih kosti (Die Tierknochenfunde). – V / In: S. Gabrovec, *Stična 1. Naselbinska izkopavanja (Stična 1. Siedlungsausgrabungen)*, Katalogi in monografije 28, 190–213.
- BONAMICI, M. 2000, Economic structure. – V / In: M. Torelli (ur. / ed.), *The Etruscans*, Milano, 73–87.
- BONDINI, A. 2005, I materiali di Montebello Vicentino. Tra cultura veneto-alpina e civiltà di La Tène. – V / In: D. Vitali (ur. / ed.), *Studi sulla media e tarda età del ferro nell'Italia settentrionale*, Studi e Scavi n. s. 12, 215–324.
- BONFANTE, L. 1981, *Out of Etruria. Etruscan influence North and South.* – BAR. International series 103.
- BONGHI-JOVINO, M. 1992, La testimonianza archeologica: elementi per un approfondimento della fenomenologia storica della presenza etrusca nell'Italia settentrionale. – V / In: L. Aigner-Foresti (ur. / ed.), *Etrusker nördlich von Etrurien*, Österreichische Akademie der Wissenschaften, Philosophisch-historische Klasse, Sitzungsberichte 589, 129–160.
- BONOMI, S. 2003, Ceramica attica ad Altino: nuovi dati. – V / In: G. Cresci Marrone, M. Tirelli (ur. / eds.), *Altinum 3, Produzioni, merci e commerci in Altino preromana e romana*. Atti del Convegno, Venezia, 12–14 dicembre 2001. Studi e ricerche sulla Gallia Cisalpina 17, 47–60.
- BONOMI PONZI, L. 1986, Colfiorito di Foligno (Perugia). – *Studi Etruschi* 54, 421–422.
- BORGNA, E., E. MONTAGNARI KOKELJ 1999, Nuove ricerche su complessi protostorici ai confini settentrionali dell'Istria. – V / In: *Protostoria e storia del "Venetorum Angulus"*. Atti del XX Convegno di Studi Etruschi ed Italici, Portogruaro, Quarto d'Altino, Este, Adria, 16–19 ottobre 1996, Pisa-Roma, 131–156.
- BORN, H. 2008, "Cesarjeva nova oblačila". Restavriranje in tehnika izdelave stiškega oklepa iz gomile 52 ("Des Kaisers neue Kleider". Restaurierung und Herstellungstechnik des Stična Brustpanzers aus Grabhügel 52). – V / In: *Stična II/2. Gomile starejše železne dobe. Razprave (Grabhügel aus der älteren Eisenzeit. Studien)*, Katalogi in monografije 38 (2010), 137–158.
- BOURDIEU, P. 2002, *Praktični čut 1, 2.* – *Studia humanitatis*, Ljubljana (= Bourdieu, P., *Le sens pratique*, Paris, 1980).
- BOŽIČ, D. 1978, Ein Beitrag zu den Doppelkreuzförmigen Gürtelhaken (K razprostranjenosti dvojnokrižnih pasnih spon). – *Arheološki vestnik* 29, 735–737.
- BOŽIČ, D. 1987, Keltska kultura u Jugoslaviji: Zapadna grupa. – V / In: *Praistorija jugoslavenskih zemalja* 5, Sarajevo, 855–897.
- BOŽIČ, D. 1991, I Taurisci. – V / In: S. Moscati et al. (ur. / eds.), *I Celti*, Milano, 471–477.
- BOŽIČ, D. 1993, Slovenija in srednja Evropa v poznolatenškem obdobju (Slovenien und Mitteleuropa in der Spätlatènezeit). – *Arheološki vestnik* 44, 137–152.
- BOŽIČ, D. 1999, Die Erforschung der Latènezeit in Slowenien seit Jahr 1964 (Raziskovanje latenske dobe na Slovenskem po letu 1964). – *Arheološki vestnik* 50, 189–213.
- BOŽIČ, D. 2009, A Hallstatt grave containing a cuirass, excavated near Stična by the Duchess of Mecklenburg in 1913. The reliability of grave groups from the Mecklenburg Collection (K halštatskemu grobu z oklepom, ki ga je leta 1913 pri Stični izkopala vojvodina Mecklenburška. O zanesljivosti grobnih celot Mecklenburške zbirke). – *Arheološki vestnik* 60, 63–95.
- BOŽIČ, D. 2010, Zum Panzergrab von Stična und der Verlässlichkeit der Grabzusammenhänge in der Sammlung Mecklenburg. – *Acta Praehistorica et Archaeologica* 42, 155–172.
- BRACCESI, L. 1979, *Grecità adriatica. Un capitolo della colonizzazione greca in Occidente.* – Bologna.
- BRACCESI, L. 1984, *La leggenda di Antenore. Da Troia a Padova.* – Il Mito e la storia 1.
- BRACCESI, L. 2003, *I Greci delle periferie. Dal Danubio all'Atlantico.* – Quaderni Laterza 120.
- BREŠČAK, D. 1982, Veliki Gaber. – *Varstvo spomenikov* 24, 156–157.
- BREŠČAK, D., B. KRIŽ 1987, Metlika / Hrib. Prazgodovinska gomila (Prehistoric tumulus). – *Arheološki pregled* 28, 74–75.
- BREUER, S. 1990, *Der archaische Staat. Zur Soziologie charismatischer Herrschaft.* – Berlin.
- BRODAR, V. 1968, Kraniološka analiza ženske lobanje iz Špilerjeve gomile, groba 5 (Kraniološke Angaben des Schädels aus Špilers Grabhügel). – *Arheološki vestnik* 19, 261–272.
- BUDJA, M. 1980, Grob 54 z žarnega grobišča na dvorišču SAZU v Ljubljani (Grab 54 aus der Urnennekropole im Hof der Slowenischen Akademie der Wissenschaften und Künste in Ljubljana). – V / In: *Zbornik posvečen Stanetu Gabrovcu ob šestdesetletnici*, Situla 20/21, 85–94.
- CALZAVARA CAPUIS, L., A. M. CHIECO BIANCHI 2006, *Este 2. Le necropoli di Villa Benvenuti.* – Monumenti antichi 64, Serie monografica 7.
- CALZAVARA CAPUIS, L., A. RUTA SERAFINI 1987, Per un aggiornamento della problematica del celtismo nel Veneto. – V / In: D. Vitali (ur. / ed.), *Celti ed Etruschi nell'Italia centro-settentrionale dal V secolo a.C. alla romanizzazione*. Atti del colloquio internazionale, Bologna 12–14 aprile 1985, Fonti e Studi 10, 281–307.
- CAPUIS, L. 2000, The Etruscans and the Veneti: Forms of Exchange and Processes of Acculturation. – V / In: M. Torelli (ur. / ed.), *The Etruscans*, Milano, 191–195.
- CAPUIS, L., G. GAMBACURTA 2001, I materiali preromani dal santuario di Altino – località 'Fornace'. – V / In: G. Cresci Marrone, M. Tirelli (ur. / eds.), *Altinum 2, Orizzonti del sacro: culti e santuari antichi in Altino e nel Veneto orientale*, Studi e ricerche sulla Gallia Cisalpina 14, 61–85.
- CAPUIS, L., G. GAMBACURTA 2003, Altino: importazioni e direttrici commerciali in epoca preromana. – V / In: G. Cresci Marrone, M. Tirelli (ur. / eds.), *Altinum 3, Produzioni, merci e commerci in Altino preromana e romana*. Atti del Convegno, Venezia, 12–14 dicembre 2001, Studi e ricerche sulla Gallia Cisalpina 17, 28–45.

- CAPUIS, L., A. RUTA SERAFINI 1996, Nuovi Documenti di Arte delle Situle nel Veneto. – V / In: E. Jerem, A. Lippert (ur. / eds.), *Osthallstattkultur. Akten des Internationalen Symposiums*, Sopron, 10.–14. Mai 1994, *Archaeolingua* 7, 37–46.
- CAPUIS L., M. RUTA SERAFINI 2002, L'uomo alato, il cavallo, il lupo: tra arte delle situle e racconti adriatici. – *Padusa* n. s. 38, 35–42.
- CARANCINI, G. L. 1975, *Die Nadeln in Italien (Gli spilloni nell'Italia continentale)*. – *Prähistorische Bronzefunde XIII/2*.
- CÀSSOLA GUIDA, P. 1996, Lineamenti di protostoria friulana. – V / In: *La protostoria tra Sile e Tagliamento. Antiche genti tra Veneto e Friuli*, Cataloghi 2, 313–320.
- CÀSSOLA GUIDA, P. 2001, Cenni sulla crisi dei castellieri e sulla riorganizzazione del territorio friulano. – V / In: S. Vitri, F. Oriolo (ur. / eds.), *I Celti in Carnia e nell'arco alpino centro orientale*. Atti della Giornata di studio, Tolmezzo 30 aprile 1999, Trieste, 349–352.
- CATTANI, M. 1987, Aes rude. – V / In: R. De Marinis (ur. / ed.), *Gli Etruschi a nord del Po*, Mantova, 204–210.
- CERCHIAI, L. 2000, The Ideology of the Etruscan City. – V / In: M. Torelli (ur. / ed.), *The Etruscans*, Milano, 243–253.
- CESTNIK, V. 2009, *Željeznodobna nekropola Kaštel kod Buja. Analiza pokopa željeznodobne Istre (Iron age necropolis Kaštel near Buje. Analysis of burial practice in the Iron Age Istria)*. – Monografije i katalozi 18.
- CHAMPION, T. C., J. V. S. MEGAW (ur. / eds.) 1985, *Settlement and society. Aspects of west European prehistory in the first millennium B.C.* – New York.
- CHERICI, A. 1999, Amuleti nei corredi funebri Paleoveneti e dell'Italia antica. – V / In: *Protostoria e storia del "Venetorum Angulus"*. Atti del XX Convegno di Studi Etruschi ed Italici, Portogruaro, Quartod'Altino, Este, Adria, 16–19 ottobre 1996, Pisa-Roma, 169–216.
- CHESSON, M. S. 2001, Social Memory, Identity, and Death. An Introduction. – *Archeological Papers of the American Anthropological Association* 10, 1–10.
- CHIECO BIANCHI, A. M. 1987, Dati preliminari su nuove tombe di III secolo da Este. – V / In: D. Vitali (ur. / ed.), *Celti ed Etruschi nell'Italia centro-settentrionale dal V secolo a. C. alla romanizzazione*, Fonti e studi 10, 191–236.
- CHIECO BIANCHI, A. M., L. CALZAVARA CAPUIS 1985, *Este 1. Le necropoli Casa di Ricovero, Casa Muletti Prosdocimi e Casa Altonsi*. – *Monumenti antichi* 51, Serie monografica 2.
- CHOCHOROWSKI, J. 1985, Die Rolle der Vekerzug-Kultur (VK) im Rahmen der skythischen Einflüsse in Mitteleuropa. – *Praehistorische Zeitschrift* 60, 204–271.
- CLARK, D. (ur. / ed.) 1993, *The sociology of death. Theory, culture, practice*. – Sociological review monographs.
- CONNOR, W. R. 2004, Early Greek land warfare as symbolic expression. – V / In: R. Osborne (ur. / ed.), *Studies in ancient Greek and Roman society*, Cambridge-New York, 12–37.
- CORAZZA, S., S. VITRI (ur. / eds.) 2001, *La necropoli di Misincinis dopo lo scavo: primi risultati delle indagini 1995–1997*. – Udine.
- COSENTINO, S., V. D'ERCOLE, G. MIELI 2003, Costumi funerari in Abruzzo tra l'età del Bronzo finale e la prima età del Ferro. – V / In: *I Piceni e l'Italia medio-adriatica*. Atti del XXII Convegno di studi etruschi ed italici, Ascoli Piceno, Teramo, Ancona, 9–13 aprile 2000, Pisa-Roma, 423–450.
- CRESCI MARRONE, G., M. TIRELLI 2003, Altino da porto dei Veneti a mercato romano. – V / In: G. Cresci Marrone, M. Tirelli (ur. / eds.), *Altinum 3, Produzioni, merci e commerci in Altino preromana e romana*. Atti del Convegno, Venezia, 12–14 dicembre 2001, Studi e ricerche sulla Gallia Cisalpina 17, 7–25.
- CURCI, A., D. VITALI (ur. / eds.) 2006, *Animali tra uomini e dei. Archeozoologia del mondo preromano*. Atti del Convegno Internazionale 8–9 novembre 2002. – Studi e Scavi n. s. 14.
- ČERČE, P., I. ŠINKOVEC 1995, Katalog depojev pozne bronaste dobe (Catalogue of Hoards of the Urnfield Culture). – V / In: B. Teržan (ur. / ed.), *Depojske in posamezne kovinske najdbe bakrene in bronaste dobe na Slovenskem 1 (Hoards and Individual Metal Finds from the Eneolithic and Bronze Ages in Slovenia 1)*, Katalogi in monografije 29, 129–232.
- ČERČE, P., P. TURK 1996, Depoji pozne bronaste dobe – najdiščne okoliščine in struktura najdb (Hoards of the Late Bronze Age – The Circumstances of their Discovery and the Structure of the Finds). – V / In: B. Teržan (ur. / ed.), *Depojske in posamezne kovinske najdbe bakrene in bronaste dobe na Slovenskem 2 (Hoards and Individual Metal Finds from the Eneolithic and Bronze Ages in Slovenia 2)*, Katalogi in monografije 30, 7–30.
- ČERNOLOGAR, K. 1892, Notizen. – *Mittheilungen der k.k. Central-Commission N. F.* 18, 127.
- ČOVIČ, B. 1961–1962, Grobnice željeznog doba iz Crvenice kod Duvna (Eisenzeitgräber aus Crvenica bei Duvno). – *Vjesnik za arheologiju i historiju dalmatinsku* 63/64 (1969), 25–48.
- ČOVIČ, B. 1987, Grupa Donja Dolina – Sanski Most. – V / In: *Praistorija jugoslavenskih zemalja* 5, Sarajevo, 232–286.
- ČREŠNAR, M. 2006, Novi žarni grobovi iz Ruš in pogrebni običaji v ruški žarnogrobiščni skupini (Die neuen Urnengräber aus Ruše und das Bestattungsritual in der Ruše-Gruppe der Urnenfelderkultur). – *Arheološki vestnik* 57, 97–162.
- DAVIES, D. J. 1997, *Death, ritual and belief. The rhetoric of funerary rites*. – London.
- DE GROSSI MAZZORIN, J. 2006, Il quadro attuale delle ricerche archeozoologiche in Etruria e nuove prospettive di ricerca. – V / In: A. Curci, D. Vitali (ur. / eds.), *Animali tra uomini e dei. Archeozoologia del mondo preromano*. Atti del Convegno Internazionale 8–9 novembre 2002, Studi e Scavi n. s. 14, 77–96.
- DE MARINIS, R. C. 1977, The La Tène Culture of the Cisalpine Gauls. – V / In: M. Guštin (ur. / ed.), *Keltske študije*, Posavski muzej Brežice 4, 23–50.
- DE MARINIS, R. 1987, Fibule tardohallstattiane occidentali dell'abito etrusco del Forcello (Bagnolo S. Vito). – V / In: D. Vitali (ur. / ed.), *Celti ed Etruschi nell'Italia centro-settentrionale dal V secolo a.C. alla romanizzazione*. Atti del colloquio internazionale, Bologna 12–14 aprile 1985, Fonti e Studi 10, 89–110.

- DE MARINIS, R. C. 1997, Il corallo nella preistoria e protoistoria dell'Italia settentrionale. – V / In: F. Marzatico, L. Endrizzi (ur. / eds.), *Ori delle Alpi*, Trento, 153–159.
- DE MARINIS, R. C. 1999, Il confine occidentale del mondo proto-veneto/paleo-veneto dal Bronzo finale alle invasioni galliche del 338 a.C. – V / In: *Protostoria e storia del "Venetorum Angulus"*. Atti del XX Convegno di Studi Etruschi ed Italici, Portogruaro, Quarto d'Altino, Este, Adria, 16–19 ottobre 1996, Pisa-Roma, 511–564.
- DE MARINIS, R. C. 2001, Il passaggio dal Golasecca al La Tène. – V / In: S. Vitri, F. Oriolo (ur. / eds.), *I Celti in Carnia e nell'arco alpino centro orientale*. Atti della Giornata di studio, Tolmezzo 30 aprile 1999, Trieste, 345–348.
- DE MARINIS, R. (ur. / ed.) 1987, *Gli Etruschi a nord del Po*. – Mantova.
- D'ERCOLE, M.-C. 2000a, Le faste et les femmes en Italie méridionale au deuxième Âge du Fer. – *Mémoires de la Société Archéologique Champenoise* 15, 461–472.
- D'ERCOLE, M.-C. 2000b, Immagini dall'Adriatico arcaico. Su alcuni temi iconografici delle stele daunie. – *Rivista di antichità* 9/2, 327–349.
- D'ERCOLE, M.-C. 2002a, *Importuosa Italiae litora. Paysage et échanges dans l'Adriatique méridionale à l'époque archaïque*. – *Études* VI.
- D'ERCOLE, M.-C. 2002b, La koiné adriatique et l'Europe centrale au VII^e siècle av. J.-C. – V / In: *Identités et cultures dans le monde méditerranéen antique*, Histoire ancienne et médiévale 69, 15–36.
- D'ERCOLE, M.-C. 2006, Back from Troy: Diomedes and Other Heroes in the Ancient Mediterranean. – V / In: M. Kokole et al. (ur. / eds.), *Mediterranean myths from classical antiquity to the eighteenth century (Mediterranski miti od antike do 18. stoletja)*, Ljubljana, 23–35.
- D'ERCOLE, M.-C. 2008, *Ambres gravés du Département des monnaies, médailles et antiques [de la Bibliothèque nationale de France]*. – Paris.
- DESCHMANN, C. 1884, Prähistorische Nachgrabungen in Krain im Jahre 1882. – *Mittheilungen der Anthropologischen Gesellschaft in Wien* 14, 49–53.
- DIAMOND, J. M. 1999, *Guns, germs, and steel. The fates of human societies*. – New York-London.
- DIZDAR, M. 2009, Željezni pojasi tipa Zvonimirovo LT 6 kao dio ženske srednjolatske nošje u zapadnoj Panoniji i na jugoistočnoalpskom prostoru (Iron belts of the Zvonimirovo LT 6 type as the part of female middle La Tène wear in the Western Pannonia and the South-Eastern Alpine area). – *Vjesnik Arheološkog muzeja u Zagrebu* 3. ser. 42, 271–304.
- DOBIAT, C. 1979, Überlegungen zur Verwendung der hallstattzeitlichen Zwergknebel. – *Archäologisches Korrespondenzblatt* 9, 191–198.
- DOBIAT, C. 1980, *Das hallstattzeitliche Gräberfeld von Kleinklein und seine Keramik*. – Schild von Steier 1.
- DOBIAT, C. 1982, *Funde aus der Sammlung Mecklenburg*. – Kleine Schriften aus dem Vorgeschichtlichen Seminar Marburg 12.
- DOBIAT, C. 1987, *Glasperlen der vorrömischen Eisenzeit 2. Ringaugenperlen und verwandte Perlengruppen. Nach Unterlagen von Thea Elisabeth Haevernick*. – Marburger Studien zur Vor- und Frühgeschichte 9.
- DOLINAR-OSOLE, Z. 1956, Ilirska okostja iz gomile v Volčjih Njivah (The Illyrian skeletons of Volčje Njive). – *Arheološki vestnik* 7, 131–136.
- DONATI, L., A. PARRINI 1999, Resti di abitazione di età arcaica ad Adria. Gli scavi di Francesco Antonio Bocchi nel Giardino Pubblico. – V / In: *Protostoria e storia del "Venetorum Angulus"*. Atti del XX Convegno di Studi Etruschi ed Italici, Portogruaro, Quarto d'Altino, Este, Adria, 16–19 ottobre 1996, Pisa-Roma, 567–614.
- DRACK, W. 1970, Zum bronzenen Ringschmuck der Hallstattzeit aus dem schweizerischen Mittelland und Jura. – *Jahrbuch der Schweizerischen Gesellschaft für Ur- und Frühgeschichte* 55, 23–87.
- DRACK, W. 1980, Steinplattengrab der mittleren Hallstattzeit bei Kloten, Kanton Zürich. – V / In: *Zbornik posvečen Stanetu Gabrovcu ob šestdesetletnici*, Situla 20/21, 301–314.
- DRAKSLER, M. 2007, Območje Zagorja ob Savi v prazgodovini (Das Gebiet von Zagorje ob Savi in der Vorgeschichte). – *Arheološki vestnik* 58, 121–155.
- DULAR, A. 1991, *Prazgodovinska grobišča v okolici Vinjega vrha nad Belo Cerkvijo (Die vorgeschichtlichen Nekropolen in der Umgebung von Vinji Vrh oberhalb von Bela Cerkev)*. – Katalogi in monografije 26.
- DULAR, J. 1973, Bela krajina in der frühen Hallstattzeit. – *Arheološki vestnik* 24 (1975), 544–591.
- DULAR, J. 1978, *Podzemelj*. – Katalogi in monografije 16.
- DULAR, J. 1979, Žarno grobišče na Borštku v Metliki (Das Urnenfeld auf Borštek in Metlika). – *Arheološki vestnik* 30, 65–100.
- DULAR, J. 1982, *Halštatska keramika v Sloveniji (Die Grabkeramik der älteren Eisenzeit in Slowenien)*. – Dela 1. razreda SAZU 23.
- DULAR, J. 1983, Gomilno grobišče v Loki pri Črnomlju (Die Hügelgräbernekropole in Loka bei Črnomelj). – *Arheološki vestnik* 34, 219–244.
- DULAR, J. 1985, *Topografsko področje XI (Bela krajina)*. – Arheološka topografija Slovenije, Ljubljana.
- DULAR, J. 2003, *Halštatske nekropole Dolenjske (Die hallstattzeitlichen Nekropolen in Dolenjsko)*. – Opera Instituti Archaeologici Sloveniae 6.
- DULAR, J. 2007a, K problematiki prostorskega umeščanja in poimenovanja arheoloških najdišč (Spatial positioning and naming of the archaeological sites reconsidered). – *Arheološki vestnik* 58, 435–443.
- DULAR, J. 2007b, Pferdegräber und Pferdebestattungen in der hallstattzeitlichen Dolenjsko-Gruppe (Konjski grobovi in pokopi konj v dolenjski halštatski skupini). – V / In: *Scripta Praehistorica in Honorem Biba Teržan*, Situla 44, 737–752.
- DULAR, J. 2008, Pogled na družbeno strukturo železnodobne Dolenjske. – *Kronika* 56, 425–434.
- DULAR, J. 2009a, Kako je nastala in zakaj je odšla na tuje Mecklenburška zbirka (The origin of the Mecklenburg collection and why it was moved abroad). – *Argo* 52/1–2, 30–47.
- DULAR, J. 2009b, Sava v bronasti in železni dobi. – V / In: *Ukročena lepota. Sava in njene zgodbe*, Sevnica, 36–41.
- DULAR, J., B. KRIŽ 1990, Železnodobno naselje in grobišče v Brezjah pri Trebelnem (Die eisenzeitliche Siedlung

- und Nekropole in Brezje bei Trebelno). – *Arheološki vestnik* 41, 531–556.
- DULAR, J., S. TECCO HVALA 2007, *South-Eastern Slovenia in the Early Iron Age: settlement, economy, society (Jugovzhodna Slovenija v starejši železni dobi: poselitev, gospodarstvo, družba)*. – Opera Instituti Archaeologici Sloveniae 12.
- EARLE, T. (ur. / ed.) 1991, *Chieftoms: power, economy and ideology*. – Boulder.
- EARLE, T., J. E. ERICSON (ur. / eds.) 1977, *Exchange Systems in Prehistory*. – New York.
- EGG, M. 1978, Eine trakoskythische Streitaxt aus Hallstatt. – *Archäologisches Korrespondenzblatt* 8, 111–117.
- EGG, M. 1980, Zum Helmfragment von Magdalenska gora. – V / In: *Zbornik posvečen Stanetu Gabrovcu ob šestdesetletnici*, Situla 20/21, 241–249.
- EGG, M. 1985a, Die hallstattzeitlichen Hügelgräber bei Helpfau-Uttendorf in Oberösterreich. – *Jahrbuch des Römisch-Germanischen Zentralmuseums Mainz* 32, 323–393.
- EGG, M. 1985b, Die hallstattzeitlichen Grabhügel vom Siedelberg in Oberösterreich. – *Jahrbuch des Römisch-Germanischen Zentralmuseums Mainz* 32, 265–322.
- EGG, M. 1986, *Italische Helme. Studien zu den ältereisenzeitlichen Helmen Italiens und der Alpen*. – Römisch-Germanisches Zentralmuseum, Monographien 11.
- EGG, M. 1988a, Die ältesten Helme der Hallstattzeit. – V / In: *Antike Helme. Sammlung Lipperheide und andere Bestände des Antikenmuseums Berlin*, Römisch-Germanisches Zentralmuseum, Monographien 14, 212–221.
- EGG, M. 1988b, Italische Helme mit Krempe. – V / In: *Antike Helme. Sammlung Lipperheide und andere Bestände des Antikenmuseums Berlin*, Römisch-Germanisches Zentralmuseum, Monographien 14, 222–270.
- EGG, M. 1996, *Das hallstattzeitliche Fürstengrab von Strettweg bei Judenburg in der Obersteiermark*. – Römisch-Germanisches Zentralmuseum, Monographien 37.
- EGG, M. 1999, Waffenbrüder? Eine ungewöhnliche Bestattung der frühlatènezeit in Novo mesto in Slowenien. – *Jahrbuch des Römisch-Germanischen Zentralmuseums Mainz* 46, 317–356.
- EGG, M. 2004a, Die Wiederentdeckung eines osthallstattischen Fürstengrabes. Anmerkungen zum Fürstengrab im Hartnermichelkogel 1 bei Kleinklein (Gem. Großklein, Bez. Leibnitz) in der Weststeiermark. – *Jahrbuch des Römisch-Germanischen Zentralmuseums Mainz* 51, 93–126.
- EGG, M. 2004b, I guerrieri. – V / In: F. Marzatico, P. Gleirscher (ur. / eds.), *Guerrieri, principi ed eroi fra il Danubio e il Po dalla Preistoria all'Alto Medioevo*, Trento, 35–55.
- EGG, M. 2009, Sozialarchäologische Betrachtungen zu den hallstattzeitlichen Fürstengräbern von Kleinklein (Bez. Leibnitz, Weststeiermark). – V / In: M. Egg, D. Quast (ur. / eds.), *Aufstieg und Untergang: Zwischenbilanz des Forschungsschwerpunktes "Studien zu Genese und Struktur von Eliten in vor- und frühgeschichtlichen Gesellschaften"*, Monographien des Römisch-Germanisches Zentralmuseums 82, 31–58.
- EGG, M. 2010, Gläserne Widderkopferlen aus der Eisenzeit. – *Archäologisches Korrespondenzblatt* 40, 525–543.
- EGG, M., A. EIBNER 2005, Einige Anmerkungen zur figural verzierten Bronzesitula aus Dolenjske Toplice in Slowenien. – *Archäologisches Korrespondenzblatt* 35/2, 191–204.
- EGG, M., D. KRAMER 2005, *Krieger – Feste – Totenopfer. Der letzte Hallstattfürst von Kleinklein in der Steiermark*. – Mosaiksteine. Forschungen am Römisch-Germanischen Zentralmuseum 1.
- EGG, M., R. LEHNERT 2011, Kampf oder Exekution? Einige Anmerkungen zu den figural verzierten Bronzesitulen aus Grab 33, Hügel III von Novo mesto-Kandija, Slowenien (Boj ali usmrtitev? Nekaj misli k figuralno okrašenima bronastima situlama iz groba 33 v gomili III iz Kandije v Novem mestu). – *Arheološki vestnik* 62, 231–262.
- EGG, M., C. PARE 1995, *Die Metallzeiten in Europa und im Vorderen Orient*. – Kataloge vor- und frühgeschichtlicher Altertümer 26.
- EGG, M., M. HAUSCHILD, M. SCHÖNFELDER 2006, Zum frühlatènezeitlichen Grab 994 mit figural verzierter Schwertscheide von Hallstatt (Oberösterreich). – *Jahrbuch des Römisch-Germanischen Zentralmuseums Mainz* 53, 175–216.
- EIBNER, A. 1981, Darstellungsinhalte in der Kunst der Hallstattkultur. – V / In: *Die Hallstattkultur*. Bericht über das Symposium in Steyr 1980, Linz, 261–296.
- EIBNER, A. 1984, Die Frau mit der Spindel. Zum Aussgewert einer archäologischen Quelle. – V / In: L. Török (ur. / ed.), *Hallstatt Kolloquium Veszprém 1984*, Budapest, 39–48.
- EIBNER, A. 2000–2001, Die Stellung der Frau in der Hallstattkultur anhand der bildlichen Zeugnisse. – *Mitteilungen der Anthropologischen Gesellschaft in Wien* 130/131, 107–136.
- EIBNER, A. 2004, Die Bedeutung der Jagd im Leben der eisenzeitlichen Gesellschaft – dargestellt anhand der Bilderüberlieferungen. – V / In: H. Heftner, K. Tomaszczik (ur. / eds.), *AD FONTES! Festschrift für Gerhard Dobesch zum 65. Geburtstag*, Wien, 621–639.
- EIBNER, A. 2009, Symbol und Bedeutung des Stabes – anhand eisenzeitlicher Bildquellen. – V / In: G. Tiefengraber, B. Kavur, A. Gaspari (ur. / eds.), *Keltske študije 2 (Studies in Celtic Archaeology), Papers in honour of Mitja Guštin*, Protohistoire Européenne 11, 11–46.
- ELES MASI, P. 1986, *Le fibule dell'Italia settentrionale*. – Prähistorische Bronzefunde 14/5.
- EROI e Regine. *Piceni Popolo d'Europa* 2001. – Roma.
- ETTEL, P. 2007, Diffusione e ricezione della moda italiana delle fibule nelle regioni transalpine. – V / In: M. Guštin et al. (ur. / eds.), *Piceni ed Europa*, *Archeologia di frontiera* 6, 135–146.
- FATH, B., B. GLUNZ-HÜSKEN 2011, Textilien und Symbole für ihre Herstellung in eisenzeitlichen Gräbern Mitteleuropas. Griechenland – Este – Frög – Sopron. – *Prähistorische Zeitschrift* 86, 254–271.
- FEKETE, M. 1973, Der Hortfund von Kisravazd. – *Acta Archaeologica Academiae Scientiarum Hungaricae* 25, 341–358.
- FINLEY, M. I. 1987, *Antična ekonomija*. – *Studia humanitatis*, Ljubljana (= Finley, M., *The ancient economy*, 1973, 1975, Berkeley-Los Angeles-London).

- FIORE, I., R. SALERNO, A. TAGLIACOZZO 2003, I cavalli paleoveneti del santuario di Altino – località "Fornace". – V / In: G. Cresci Marrone, M. Tirelli (ur. / eds.), *Altinum 3, Produzioni, merci e commerci in Altino preromana e romana*. Atti del Convegno, Venezia, 12–14 dicembre 2001, Studi e ricerche sulla Gallia Cisalpina 17, 115–141.
- FISHER, F. 1973, Keimelia. – *Germania* 51/2, 436–459.
- FOGOLARI, G. 1996, I Veneti antichi: inquadramento generale. – V / In: *La protostoria tra Sile e Tagliamento. Antiche genti tra Veneto e Friuli*, Cataloghi 2, 19–23.
- FOSSATI, A. 2006, La rappresentazioni zoomorfe nell'arte rupestre dello stile quarto di Valcamonica (età del Ferro): tipologie, etologia e significati. – V / In: A. Curci, D. Vitali (ur. / eds.), *Animali tra uomini e dei. Archeozoologia del mondo preromano*. Atti del Convegno Internazionale 8–9 novembre 2002, Studi e Scavi n. s. 14, 27–44.
- FREY, O.-H. 1966, Der Ostalpenraum und die antike Welt in der frühen Eisenzeit. – *Germania* 44/1, 48–66.
- FREY, O.-H. 1969, *Die Entstehung der Situlenkunst. Studien zur figürlich verzierten Toreutik von Este*. – Römisch-Germanische Forschungen 31.
- FREY, O.-H. 1971, Fibeln vom westhallstädtischen Typus aus dem Gebiet südlich der Alpen. – V / In: *Oblatio, Raccolta di studi di antichità in onore di Aristide Calderini*, Como, 355–386.
- FREY, O.-H. 1973, Bemerkungen zur hallstädtischen Bewaffnung in Südostalpenraum (Pripombe k halštatski obožitvi v jugovzhodnem alpskem prostoru). – *Arheološki vestnik* 24 (1975), 621–636.
- FREY, O.-H. 1974a, Durchbrochene Frühlatènegürtelhaken aus Slowenien. – V / In: *Opuscula Iosepho Kastelic Sexagenario Dicata*, Situla 14/15, 129–142.
- FREY, O.-H. 1974b, Schwarz-rot gebänderte Keramik in der Zone südlich der Alpen. – *Hamburger Beiträge zur Archäologie* 4, 97–102.
- FREY, O.-H. 1980a, Zur Tragweise hallstattzeitlicher Dolche in Slowenien. – V / In: *Zbornik posvečen Stanetu Gabrovcu ob šestdesetletnici*, Situla 20/21, 333–342.
- FREY, O.-H. 1980b, Der Westhallstattkreis im 6. Jahrhundert v. Chr. – V / In: K. Pömer, D. Straub (ur. / eds.), *Die Hallstattkultur. Frühform europäischer Einheit*, Linz, 80–116.
- FREY, O.-H. 1980c, Ein Zierstück der späten Hallstattzeit von der Magdalenska gora bei Šmarje. – V / In: *Die Hallstattkultur. Bericht über das Symposium in Steyr 1980*, Linz, 227–240.
- FREY, O.-H. 1980d, La cronologia di Este nel quadro dei rapporti culturali con l'area hallstattiana. – V / In: *Este e la civiltà paleoveneta a cento anni dalle prime scoperte*, Firenze, 69–84.
- FREY, O.-H. 1987, Sui ganci di cintura celtici e sulla prima fase di La Tène nell'Italia del Nord. – V / In: D. Vitali (ur. / ed.), *Celti ed Etruschi nell'Italia centro-settentrionale dal V secolo a.C. alla romanizzazione*. Atti del colloquio internazionale, Bologna 12–14 aprile 1985, Fonti e Studi 10, 9–22.
- FREY, O.-H. 1989, Mediterranes Importgut im Südostalpengebiet. – V / In: *La civilisation de Hallstatt*, Bilan d'une rencontre, Liège 1987, Liège, 293–306.
- FREY, O.-H. 1998, "Hallstatt und Altitalien". Zur Bedeutung des mediterranen Imports. – V / In: *Archäologische Untersuchungen zu den Beziehungen zwischen Altitalien und der Zone nordwärts der Alpen während der frühen Eisenzeit Alteuropas*, Regensburger Beiträge zur prähistorischen Archäologie 4, 265–284.
- FREY, O.-H. 2007, Über die Ostalpen zur Keltiké. Beziehungen zwischen der Situlenkunst / Este-Kunst und dem Latène A-Kreis. – V / In: *Scripta Praehistorica in Honorem Biba Teržan*, Situla 44, 777–788.
- FREY, O.-H., S. GABROVEC 1971, Zur Chronologie der Hallstattzeit im Ostalpenraum. – V / In: *Actes du VIII^e Congrès international des sciences préhistoriques et protohistoriques* 1, Beograd, 193–218.
- FRIED, M. H. 1967, *The evolution of political society. An essay in political anthropology*. – New York.
- GABROVEC, S. 1956, Ilirska gomila v Volčjih njivah (The illyrian tumulus at Volčje njive). – *Arheološki vestnik* 7, 62–130.
- GABROVEC, S. 1960a, *Prazgodovinski Bled (The prehistory of Bled)*. – Dela 1. Razreda SAZU 12/8.
- GABROVEC, S. 1960b, Grob z oklepom iz Novega mesta (Panzergrab von Novo mesto). – *Situla* 1, 27–79.
- GABROVEC, S. 1962–1963, Halštatske čelade jugovzhodnoalpskega kroga (Die hallstädtischen Helme des südostalpinen Kreises). – *Arheološki vestnik* 13/14, 293–347.
- GABROVEC, S. 1964, Problem severozahodnega področja Ilirov (Das Problem des nordwestillyrischen Gebietes). – V / In: *Simpozijum o teritorijalnom i hronološkom razgraničenju Ilira u praistorijsko doba*, Posebna izdanja / Naučno društvo SR Bosne i Hercegovine 4, Centar za balkanološka ispitivanja 1, 215–253.
- GABROVEC, S. 1964–1965a, Halštatska kultura v Sloveniji (Die Hallstattkultur Sloweniens). – *Arheološki vestnik* 15/16, 21–64.
- GABROVEC, S. 1964–1965b, Najstarejša grobna celota z upodobitvijo v situlskem stilu (Das älteste geschlossene Grab mit einem Situlendenkmal in Slowenien). – *Arheološki vestnik* 15/16, 127–135.
- GABROVEC, S. 1965a, Kamniško ozemlje v prazgodovini. – *Kamniški zbornik*, Kamnik, 89–134.
- GABROVEC, S. 1965b, Kronologija čelad negovskega tipa. – *Situla* 8, 177–186.
- GABROVEC, S. 1965–1966, Pomen groba s sestavljeno čelado z Vač (Das Helmgrab von Vače und seine Bedeutung für den Südostalpen Kreis). – *Zgodovinski časopis* 19/20, 81–90.
- GABROVEC, S. 1966a, Zur Hallstattzeit in Slowenien. – *Germania* 44, 1–48.
- GABROVEC, S. 1966b, Zagorje v prazgodovini (Zagorje in der Vorgeschichte). – *Arheološki vestnik* 17, 19–50.
- GABROVEC, S. 1966c, Srednjelatensko obdobje v Sloveniji (Zur Mittelatènezeit in Slowenien). – *Arheološki vestnik* 17, 169–242.
- GABROVEC, S. 1968, Grob s trinožnikom iz Novega mesta (Das Dreifussgrab aus Novo mesto). – *Arheološki vestnik* 19, 157–188.
- GABROVEC, S. 1970, Dvozankaste ločne fibule. Doprinos k problematiki začetka železne dobe na Balkanu in v jugovzhodnih Alpah (Die Zweischleifige Bogenfibeln. Ein Beitrag zum Beginn der Hallstattzeit am Balkan

- und in den Südalpen). – *Godišnjak 8, Centar za balkanološka ispitivanja* 6, 5–67.
- GABROVEC, S. 1973, Začetek halštatskega obdobja v Sloveniji (Der Beginn der Eisenzeit in Slowenien). – *Arheološki vestnik* 24 (1975), 338–385.
- GABROVEC, S. 1974a, Die Ausgrabungen in Stična und ihre Bedeutung für die südostalpine Hallstattkultur. – V / In: *Symposium zu Problemen der jüngeren Hallstattzeit in Mitteleuropa*, Smolenice 1970, Bratislava, 163–187.
- GABROVEC, S. 1974b, Halštatske nekropole v Bohinju (Die Hallstattnekropolen in Bohinj). – *Arheološki vestnik* 25, 287–318.
- GABROVEC, S. 1975a, Naselitvena zgodovina Slovenije v halštatskem obdobju. – V / In: *Arheološka najdišča Slovenije*, Ljubljana, 55–60.
- GABROVEC, S. 1975b, Magdalenska gora. – V / In: *Arheološka najdišča Slovenije*, Ljubljana, 200–201.
- GABROVEC, S. 1976–1977, La necropoli dell'età del ferro di Caporetto. – *Atti dei Civici musei di storia ed arte di Trieste* 9, 27–52.
- GABROVEC, S. 1978, Dolga pota stiških izkopanin. – *Zbornik občine Grosuplje* 10, Grosuplje, 127–145.
- GABROVEC, S. 1983, Jugoistočnoalpska regija sa zapadnom Panonijom (Uvod, Rano brončano doba, Srednje brončano doba, Kasno brončano doba, Kultura polja sa žarama). – V / In: *Praistorija jugoslavenskih zemalja* 4, Sarajevo, 21–96.
- GABROVEC, S. 1987, Jugoistočnoalpska regija sa zapadnom Panonijom (Uvod, Dolenjska grupa, Svetolucijska grupa, Notranjska grupa, Ljubljanska grupa). – V / In: *Praistorija jugoslavenskih zemalja* 5, Sarajevo, 25–182.
- GABROVEC, S. 1990a, Magdalenska gora. – V / In: *Arheološka najdišča Dolenjske*. Ob 100-letnici arheoloških raziskovanj v Novem mestu, Arheo – Dossier Dolenjska, Ljubljana, 39–42.
- GABROVEC, S. 1990b, Grob s čelado s Trbinca pri Mirni (Das Helmgrab von Trbinc bei Mirna). – *Arheološki vestnik* 41, 105–120.
- GABROVEC, S. 1992a, Etruskischer Niederschlag in Slowenien. – V / In: L. Aigner-Foresti (ur. / ed.), *Etrusker nördlich von Etrurien*, Österreichische Akademie der Wissenschaften, Philosophisch-historische Klasse, Sitzungsberichte 589, 203–218.
- GABROVEC, S. 1992b, La regione a Sud-Est delle Alpi e la civiltà picena. – V / In: M. Dardari (ur. / ed.), *La civiltà picena nelle Marche, Studi in onore di Giovanni Annibaldi*, Ancona, 10–13 luglio 1988, Ripatransone, 242–254.
- GABROVEC, S. 1994, *Stična I. Naselbinska izkopavanja (Siedlungsausgrabungen)*. – Katalogi in monografije 28.
- GABROVEC, S. 1999, 50 Jahre Archäologie der älteren Eisenzeit in Slowenien (50 let arheologije starejše železne dobe v Sloveniji). – *Arheološki vestnik* 50, 145–188.
- GABROVEC, S. 2008, Stiške gomile (Stična – Grabhügel). – V / In: *Stična II/2. Gomile starejše železne dobe. Razprave (Grabhügel aus der älteren Eisenzeit. Studien)*, Katalogi in monografije 38 (2010), 7–60.
- GABROVEC, S., K. MIHOVIČ 1987, Istarska grupa. – V / In: *Praistorija jugoslavenskih zemalja* 5, Sarajevo, 293–338.
- GABROVEC, S., B. TERŽAN 2008, *Stična II/2. Gomile starejše železne dobe. Razprave (Grabhügel aus der älteren Eisenzeit. Studien)*. – Katalogi in monografije 38 (2010).
- GABROVEC, S., A. KRUIH, I. MURGELJ, B. TERŽAN 2006, *Stična II/1. Gomile starejše železne dobe (Grabhügel aus der älteren Eisenzeit)*. – Katalogi in monografije 37.
- GAMBACURTA, G. 2003, Le sepolture equine nelle necropoli di Altino. – V / In: G. Cresci Marrone, M. Tirelli (ur. / eds.), *Altinum 3, Produzioni, merci e commerci in Altino preromana e romana*. Atti del Convegno, Venezia, 12–14 dicembre 2001, Studi e ricerche sulla Gallia Cisalpina 17, 89–113.
- GAMBACURTA, G. 2005, Padova, necropoli orientale tra via Tiepolo e via S. Massimo: la tomba 159/1991. – V / In: D. Vitali (ur. / ed.), *Studi sulla media e tarda età del ferro nell'Italia settentrionale*, Studi e scavi n. s. 12, 325–324.
- GENTILI, G. V. 2003, *Verucchio Villanoviana. Il sepolcreto in località Le Pegge e la necropoli al piede della Rocca Malatestiana*. – Monumenti antichi 59.
- GESELOWITZ, M. N. 1985, Metallographic analysis of a spear from the Mecklenburg collection. – *Arheološki vestnik* 36, 131–135.
- GEUPEL, F. 1972, Funde der späten Hallstattzeit aus Krajina, Slovenija. – *Forschungen und Berichte, Staatliche Museen zu Berlin* 14, 203–208.
- GIMBUTAS, M. 1989, *The language of the goddess*. – London.
- GLEIRSCHER, P. 1997, Hallstattzeitliche Kleinfunde aus der Durezza-Schachthöhle. – *Neues aus Alt-Villach, Jahrbuch des Stadtmuseums* 34, 31–53.
- GLEIRSCHER, P. 2001, Norische Könige. Historische Quellen und archäologischer Befund. – *Praehistorische Zeitschrift* 76, 87–104.
- GLEIRSCHER, P. 2005, Hügelgräber und Herrschaftsbereiche im Ostalpenraum. – *Arheološki vestnik* 56, 99–112.
- GLEIRSCHER, P. 2006, Urnenfelderzeitliche Grabhügel und Siedlungen der älteren Hallstattkultur in der Steiermark. Zum Beginn der Hallstattkultur im Süostalpenraum (Žarnogrobišnodobne gomile in naselja starejše halštatske kulture na Štajerskem. K začetku halštatske kulture na območju jugovzhodnih Alp). – *Arheološki vestnik* 57, 85–95.
- GLEIRSCHER, P. 2008a, Zum Grab des Schwerträgers von der Napoleonswiese über Warmbad Villach. Ein Nachtrag einschließlich drei, der verschollen geglaubten Gefäße (O grobu bojevnika z mečem z Napoleonovega travnika nad Beljaškimi Toplicami). – *Arheološki vestnik* 59, 213–225.
- GLEIRSCHER, P. 2008b, Zu Gast bei den norischen Königen von Waisenberg. Herdgerät und Trinkgeschirr aus dem zweiten Prunkgrab. – *Rudolfinum. Jahrbuch des Landesmuseums Kärnten* (2009), 35–58.
- GLEIRSCHER, P. 2009, Bildgeschichten und ihre Deutung. Zwei hallstattzeitliche Neufunde aus Kärnten. – *Archäologie Österreichs* 20/2, 4–16.
- GLUNZ, B. E. 1997, *Studien zu den Fibeln aus dem Gräberfeld von Hallstatt*. – Linzer Archäologische Forschungen 25.
- GLUNZ-HÜSKEN, B. 2008, Neue Fibeln aus der Nekropole von Hallstatt. Mit Exkursen zu Fibelneufunden anderer

- Gattungen, zur Emblematik an hallstattzeitlichen Gewandverschlüssen und einem Vergleich der Friedhöfe Hallstatt und Bischofshofen. – *Archaeologia Austriaca* 92 (2011), 35–72.
- GNOLI, G., VERNANT, J.-P. (ur. / eds.) 1982, *La mort, les morts dans les sociétés anciennes*. – Cambridge.
- GRAHEK, L. 2004, Halštatska gomila na Hribu v Metliki (A Hallstatt tumulus at Hrib in Metlika). – *Arheološki vestnik* 55, 111–206.
- GRILLI, A. 1991, L'arco adriatico fra preistoria e leggenda. – V / In: *Preistoria e protostoria dell'alto Adriatico*, Antichità Altoadriatiche 37, 15–44.
- GRÖMER, K. 2005, Efficiency and technique – Experiments with original spindle whorls. – V / In: P. Bichler et al. (ur. / eds.), *Hallstatt textiles. Technical analysis, scientific investigation and experiment on Iron Age textiles*, BAR. International series 1351, 107–116.
- GRÖMER, K., T. STÖLLNER 2009, Ein abgerissener Ärmel aus dem Salzbergwerk Dürrnberg. Neue Erkenntnisse zur Brettchenwebtechnik in der Eisenzeit in Mitteleuropa. – *Jahrbuch des Römisch-Germanischen Zentralmuseums Mainz* 56/1, 105–157.
- GUGGISBERG, M., T. STÖLLNER 1996, Ein "Herr der Tiere" im südlichen Ostalpenraum? Bemerkungen zur frühlatènezeitlichen Stellung einiger Neufunde aus dem Führholz bei Völkermarkt/Kärnten. – V / In: T. Stöllner (ur. / ed.), *Europa celtica. Untersuchungen zur Hallstatt- und Latènekultur*, Veröffentlichung des Vorgeschichtlichen Seminars Marburg 12, 117–153.
- GUIDI, A. 1983, *Scambi tra la cerchia hallstattiana orientale e il mondo a Sud delle Alpi nel VII secolo a. C.* – Kleine Schriften aus dem Vorgeschichtliches Seminar Marburg 13.
- GUIDI, A. 2004, Teorie dell'organizzazione sociale. – V / In: F. Marzatico, P. Gleirscher (ur. / eds.), *Guerrigieri, principi ed eroi fra il Danubio e il Po dalla Preistoria all'Alto Medioevo*, Trento, 67–73.
- GUŠTIN, M. 1973, Kronologija notranjske skupine (Cronologia del gruppo preistorico della Notranjska (Carniola Interna)). – *Arheološki vestnik* 24 (1975), 461–506.
- GUŠTIN, M. 1974a, Mahaire. Doprinos k povezavam Pice-na, Slovenije in Srednjega Podonavja v 7. stol. pr. n. št. (Mahaira Krummschwerter: Urgeschichtliche Verbindungen Picenum – Slowenien – Basarabi). – V / In: *Opuscula Iosepho Kastelic Sexagenario Dicata*, Situla 14/15, 78–94.
- GUŠTIN, M. 1974b, Gomile starejše železne dobe iz okolice Boštanja (Die eisenzeitlichen Grabhügel aus der Umgebung von Boštanj). – V / In: *Varia archaeologica*, Posavski muzej Brežice 1, 87–119.
- GUŠTIN, M. 1976, *Libna*. – Posavski muzej Brežice 3.
- GUŠTIN, M. 1977, Relativna kronologija grobov "Mokronoške skupine" (Relative chronology of the graves of the "Mokronog group"). – V / In: M. Guštin (ur. / ed.) *Keltske študije*, Posavski muzej Brežice 4, 67–103.
- GUŠTIN, M. 1979, *Notranjska. K začetkom železne dobe na severnem Jadranu (Zu den Anfängen der Eisenzeit an der nördlichen Adria)*. – Katalogi in monografije 17.
- GUŠTIN, M. 1980, Ante tubam. – V / In: *Zbornik posvečen Stanetu Gabrovcu ob šestdesetletnici*, Situla 20/21, 251–257.
- GUŠTIN, M. 1984, Die Kelten in Jugoslawien – Übersicht über das archäologische Fundgut. – *Jahrbuch des Römisch-Germanischen Zentralmuseums Mainz* 31, 305–364.
- GUŠTIN, M. 1991, *Posočje in der jüngeren Eisenzeit (Posočje v mlajši železni dobi)*. – Katalogi in monografije 27.
- GUŠTIN, M. 1996, Der Grabhügel der älteren Hallstattzeit aus Velike Malence (Brežice/Slowenien). – V / In: E. Jerem, A. Lippert (ur. / eds.), *Osthallstattkultur*. Akten des Internationalen Symposiums, Sopron, 10.–14. Mai 1994, *Archaeolingua* 7, 115–126.
- GUŠTIN, M. 2001, I Celti dell'Adriatico. Carni tra fonti storiche e archaeologia. – V / In: *Gli echi della terra. Presenze celtiche in Friuli: dati materiali e momenti dell'immaginario*. Convegno di studi, Castello di Gorizia, 5–7 ottobre 2001, Pisa, 11–20.
- GUŠTIN, M. 2005, Celts on the margin of the northern Adriatic. – V / In: H. Dobrzańska et al. (ur. / eds.), *Celts on the margin. Studies in European Cultural Interaction 7th century BC–1st century AD*, Kraków, 49–55.
- GUŠTIN, M. 2007, Argo, come una freccia scoccata in volo. – V / In: M. Guštin et al. (ur. / eds.), *Piceni ed Europa*, *Archeologia di frontiera* 6, 7–20.
- GUŠTIN, M., T. KNIFIC 1973, Halštatske in antične najdbe iz Javorja (Funde aus Hallstatt- und Römerzeit in Javor). – *Arheološki vestnik* 24 (1975), 831–847.
- GUŠTIN, M., B. KRIŽ 2007, Lady and her attire: reflections of status and cult in grave 30/4 from Ivanec near Družinska vas. – V / In: *Scripta Praehistorica in Honorem Biba Teržan*, Situla 44, 491–503.
- GUŠTIN, M., A. PRELOŽNIK 2005, Sajevice. Železnodobno gomilno grobišče ob Krki (Sajevice. An Iron Age barrow cemetery at the Krka River). – *Arheološki vestnik* 56, 113–168.
- GUŠTIN, M., B. TERŽAN 1975, Malenškova gomila v Novem mestu. – *Arheološki vestnik* 26, 188–202.
- GUŠTIN, M., P. ETTEL, M. BUORA (ur. / eds.) 2007, *Piceni ed Europa*. – *Archeologia di frontiera* 6.
- HADŽI, D., B. OREL 1978, Spektrometrične raziskave izvora jantarja in smol iz prazgodovinskih najdišč na Slovenskem. – *Vestnik Slovenskega kemijskega društva* 25/1, 51–62.
- HAEVERNICK, Th. E. 1959, Beiträge zur Geschichte des antiken Glases. – *Jahrbuch des Römisch-Germanischen Zentralmuseums Mainz* 6, 57–65.
- HAEVERNICK, Th. E. 1974, Zu den Glasperlen in Slowenien. – V / In: *Opuscula Iosepho Kastelic Sexagenario Dicata*, Situla 14/15, 61–65.
- HAEVERNICK, Th. E. 1981, *Beiträge zur Glasforschung. Die wichtigsten Aufsätze von 1938 bis 1981*. – Mainz am Rhein.
- HAEVERNICK, Th. E., H. MATTHÄUS, C. BRAUN, O.-H. FREY (ur. / eds.) 1983, *Glasperlen der vorrömischen Eisenzeit 1*. – Marburger Studien zur Vor- und Frühgeschichte 5.
- HAFNER, A. 1989, *Gräber, Spiegel des Lebens. Zum Totenbrauchtum der Kelten und Römer am Beispiel des Treverer-Gräberfeldes Wederath-Belginum*. – Schriftenreihe des Rheinischen Landesmuseums Trier 2.
- HAFNER, A. 1992, Die frühlatènezeitlichen Fürstengräber von Hochscheid im Hunsrück. – *Trierer Zeitschrift* 55, 25–103.

- HAFFNER, A., M. LÄGE 2008–2009, Die frühkeltische Fürstengrabnekropole von Bescheid, "Bei den Hübeln", Kreis Trier-Saarburg. – *Trierer Zeitschrift* 71/72, 27–142.
- HANSEN, L. 2010, Hochdorf VIII. Die Goldfunde und Trachtbeigaben des späthallstattzeitlichen Fürstengrabes von Eberdingen-Hochdorf (Kr. Ludwigsburg). – Forschungen und Berichte zur Vor- und Frühgeschichte in Baden-Württemberg 118.
- HÄNSEL, B. 1995 (ur. / ed.), *Handel, Tausch und Verkehr im Bronze- und früheisenzeitlichen Südosteuropa*. – Prähistorische Archäologie in Südosteuropa 11.
- HÄNSEL, B., D. MATOŠEVIĆ, K. MIHOVILIĆ, B. TERŽAN 2007, O socialnoj arheologiji brončanodobnog utvrdenog naselja i grobova na Monkodonji. – *Histria archaeologica* 38/39, 81–122.
- von HASE, F. W. 1992, Etrurien und Mitteleuropa. Zur Bedeutung der ersten italisch-etruskischen Funde der späten Urnenfelder- und frühen Hallstattzeit in Zentraleuropa. – V / In: L. Aigner-Foresti (ur. / ed.), *Etrusker nördlich von Etrurien*, Österreichische Akademie der Wissenschaften, Philosophisch-historische Klasse, Sitzungsberichte 589, 235–266.
- von HASE, F. W. 1998, Einige Überlegungen zum Fernhandel und Kulturtransfer in der jüngeren Hallstattzeit. Altitalien und Mitteleuropa. – V / In: *Archäologische Untersuchungen zu den Beziehungen zwischen Altitalien und der Zone nordwärts der Alpen während der frühen Eisenzeit Alteuropas*, Regensburger Beiträge zur prähistorischen Archäologie 4, 285–319.
- von HASE, F. W. 2003, Il guerriero di Hirschlanden. La problematica della genesi della statua-stele alla luce di vecchie e recenti scoperte. – V / In: *I Piceni e l'Italia medio-adriatica*. Atti del XXII Convegno di studi etruschi ed italici, Ascoli Piceno, Teramo, Ancona, 9–13 aprile 2000, Pisa-Roma, 361–378.
- HEIMANN, F. 2007, Kontakte in der Späthallstattzeit – Soziale und chorologische Untersuchungen zu Paukenfibeln und deren Auswirkung auf die chronologische Bewertung der Späthallstattzeit. – V / In: *Scripta Praehistorica in Honorem Biba Teržan*, Situla 44, 453–463.
- HELLMUTH, A. 2007a, Ein Bogenschütze in Picenum. – V / In: M. Guštin et al. (ur. / eds.), *Piceni ed Europa*, *Archeologia di frontiera* 6, 201–210.
- HELLMUTH, A. 2007b, Neues zum "Bogenschützengrab" aus Libna. – V / In: *Scripta Praehistorica in Honorem Biba Teržan*, Situla 44, 466–475.
- HELLMUTH, A. 2008, K rekonstrukciji razkošnega oblačila iz stiškega groba 27 v gomili 48 (Zur Rekonstruktion des Prunkgewandes aus Stična Grab 27, Grabhügel 48). – V / In: S. Gabrovec, B. Teržan, *Stična II/2. Gomile starejše železne dobe. Razprave (Grabhügel aus der älteren Eisenzeit. Studien)*, Katalogi in monografije 38 (2010), 61–68.
- HELLMUTH, A. 2010, *Bogenschützen des Pontischen Raumes in der Ältern Eisenzeit. Typologische Gliederung, Verbreitung und Chronologie der skythischen Pfeilspitzen*. – *Universitätsforschungen zur prähistorischen Archäologie* 177.
- HENCKEN, H. 1968a, *Tarquiniia, Villanovans, and early Etruscans*. – American School of Prehistoric Research, Bulletin 23.
- HENCKEN, H. 1968b, Introduction. – *Mecklenburg Collection Part 1*, American School of Prehistoric Research, Bulletin 25, v–viii.
- HENCKEN, H. 1971, *The earliest European helmets: Bronze Age and early Iron Age*. – American School of Prehistoric Research, Bulletin 28.
- HENCKEN, H. 1974, Bracelets of lead-tin alloy from Magdalenska gora. – V / In: *Opuscula Iosepho Kastelic Sexagenario Dicata*, Situla 14/15, 119–127.
- HENCKEN, H. 1978, *The Iron Age Cemetery of Magdalenska gora in Slovenia*. – Mecklenburg Collection Part 2, American School of Prehistoric Research, Bulletin 32.
- HIRSCHBÄCK MERHAR, G. 1984, Prazgodovinski depo Debeli vrh nad Predgradom (The prehistoric depot Debeli vrh above the village Predgrad). – *Arheološki vestnik* 35, 90–109.
- HODDER, I. (ur. / ed.) 1982, *Symbolic and structural archaeology*. – Cambridge-New York.
- HODDER, I. (ur. / ed.) 1991, *The meanings of things. Material culture and symbolic expression*. – One world archaeology 6.
- HODSON, F. R. 1990, *Hallstatt – the Ramsauer graves. Quantification and analysis*. – Römisch-Germanisches Zentralmuseum, Monographien 16.
- HOERNES, M. 1915, Krainische Hügelnekropolen der jüngeren Hallstattzeit. – *Wiener Praehistorische Zeitschrift* 2, 98–123.
- HORVAT, J. 1983, Prazgodovinske naselbinske najdbe pri farni cerkvi v Kranju (Vorgeschichtliche Siedlungsfunde bei der Pfarrkirche in Kranj). – *Arheološki vestnik* 34, 140–218.
- HUMPHREYS, S. C. 1994, *The family, women and death. Comparative studies*. Second edition. – Ann Arbor.
- HUMPHREYS, S. C., H. KING (ur. / eds.) 1981, *Mortality and immortality. The anthropology and archaeology of death*. – London-New York.
- HUNTER, J., M. COX 2005, *Forensic archaeology: advances in theory and practice*. – London-New York.
- HUTH, C. 2003, *Menschenbilder und Menschenbild. Anthropomorphe Bildwerke der frühen Eisenzeit*. – Berlin.
- ISTENIČ, J. 1985, Zapisi v venetski pisavi na Koroškem in v Sloveniji (Venetische Schrift in Kärnten und in Slowenien). – *Zgodovinski časopis* 39/4, 313–334.
- JABLONKA, P. 2001, Die Gurina bei Dellach im Gailtal. Siedlung, Handelsplatz und Heiligtum. – *Aus Forschung und Kunst* 33.
- JENSEN, C. K., K. H. NIELSEN (ur. / eds.) 1997, *Burial & society. The chronological and social analysis of archaeological burial data*. – Aarhus.
- JEREB, M. 2005, *Prazgodovinske bronaste posode s področja današnje Slovenije*. – Neobjavljeno diplomsko delo / Unpublished graduate thesis, Oddelek za arheologijo Filozofska fakulteta Univerze v Ljubljani.
- JEREM, E.G. 1968, The Late Iron Age Cemetery of Szentlőrinc. – *Acta Archaeologica Academiae Scientiarum Hungaricae* 20, 159–208.
- JEREM, E.G. 1973, Zur Geschichte der späten Eisenzeit in Transdanubien. Späteisenzeitliche Grabfunde von Beremend (Komitat Baranya). – *Acta Archaeologica Academiae Scientiarum Hungaricae* 25, 65–86.

- JERIN, B. 2001, *Čolničaste fibule v Sloveniji*. – Neobjavljeno diplomsko delo / Unpublished graduate thesis, Oddelek za arheologijo Filozofska fakulteta Univerze v Ljubljani.
- KATIČIČ, R. 1989, Diomed na Jadranu (Diomedes an der Adria). – *Godišnjak* 27, *Centar za balkanološka ispitivanja* 25, 39–78.
- KEMENCZEI, T. 2009, *Studien zu den Denkmälern skytisch geprägter Alföld Gruppe*. – *Inventaria Praehistorica Hungariae* 12.
- KIBBERT, K. 1984, *Die Äxte und Beile im mittleren Westdeutschland* 2. – *Prähistorische Bronzefunde* IX/13.
- KILIAN-DIRLMEIER 1975, *Gürtelhaken, Gürtelbleche und Blechgürtel der Bronzezeit in Mitteleuropa*. – *Prähistorische Bronzefunde* XII/2.
- KIMMIG, W. 1974, Zum fragment eines Este-gefäßes von der Heuneburg an der oberen Donau. – *Hamburger Beiträge zur Archäologie* 4, 33–96.
- KIMMIG, W. 1983, Die griechische Kolonisation im westlichen Mittelmeergebiet und ihre Wirkung auf die Landschaften des westlichen Mitteleuropa. – *Jahrbuch des Römisch-Germanischen Zentralmuseums Mainz* 30, 3–78.
- KIRIGIN, B., S. ČAČE 1998, Archaeological Evidence for the Cult of Diomedes in the Adriatic. – *Hesperia* 9, 63–110.
- KNEZ, T. 1966, Žarno grobišče v Novem mestu (Das Urnengräberfeld in Novo mesto). – *Arheološki vestnik* 17, 51–10.
- KNEZ, T. 1967, Žarni grobovi v Bršljinu (Gräber der Urnenfelderzeit in Bršljin). – *Arheološki vestnik* 18, 155–161.
- KNEZ, T. 1984, Žarno grobišče v Novem mestu. Začasno poročilo o raziskovanju v letu 1982 (Das Urnengräberfeld in Novo mesto. Vorbericht der Grabung 1982). – *Arheološki vestnik* 35, 119–133.
- KNEZ, T. 1986, *Novo mesto* 1. *Halštatski grobovi (Hallstattzeitliche Gräber)*. – *Carniola Archaeologica* 1.
- KNEZ, T. 1993, *Novo mesto* 3. *Kapiteljska njiva. Knežja gomila (Fürstengrabhügel)*. – *Carniola Archaeologica* 3.
- KNIFIC, T., T. NABERGOJ, N. TRAMPUŽ OREL 1997, Zbirka 80, Slovenija, najdišča neznana. – *Varstvo spomenikov* 36, 267–269.
- KOCH, L. C. 2010, *Die Glasbügelfibeln des 8. und 7. Jahrhunderts v. Chr. aus Etrurien. Ein Beitrag zur eisenzeitlichen Glastechnik und zu den Bestattungssitten des Orientalizante*. – *Universitätsforschungen zur prähistorischen Archäologie* 190.
- KOHLER, Chr. 2000, Die Obeloi der Heuneburg. – V / In: W. Kimmig, E. Böhr (ur. / eds.), *Importe und mediterrane Einflüsse auf der Heuneburg*, Heuneburgstudien 11, Römisch-germanische Forschungen 59, 197–213.
- KOS, P. 1973, Koritnica ob Bači (Koritnica an der Bača). – *Arheološki vestnik* 24 (1975), 848–873.
- KOSSACK, G. 1954a, *Studien zum Symbolgut der Urnenfelder- und Hallstattzeit Mitteleuropas*. – *Römisch-Germanische Forschungen* 20.
- KOSSACK, G. 1954b, Pferdegeschirr aus Gräbern der älteren Hallstattzeit Bayerns. – *Jahrbuch des Römisch-Germanischen Zentralmuseums Mainz* 1, 111–178.
- KOSSACK, G. 1959, *Südbayern während der Hallstattzeit*. – *Römisch-Germanische Forschungen* 24.
- KOSSACK, G. 1996, Religiöses Denken in Alteuropa vom 8. bis zum 6. Jahrhundert v. Chr. Geb. – V / In: *Archäologische Forschungen zum Kultgeschehen in der jüngeren Bronzezeit und frühen Eisenzeit Alteuropas*, Regensburger Beiträge zur Prähistorischen Archäologie 2, 17–42.
- KOSSACK, G. 1999, *Religiöses Denken in dinglicher und bildlicher Überlieferung Alteuropas aus der Spätbronze- und frühen Eisenzeit (9.–6. Jahrhundert v. Chr. Geb.)*. – Bayerische Akademie der Wissenschaften, Philosophisch-Historische Klasse 116.
- KRAUSSE, D. (ur. / ed.) 2010, "Fürstensitze" und Zentralorte der frühen Kelten. Abschlusskolloquium des DFG-Schwerpunktprogramms 1171 in Stuttgart, 12–15. Oktober 2009. – *Forschungen und Berichte zur Vor- und Frühgeschichte in Baden-Württemberg* 120.
- KRIŽ, B. 1991, *Metlika – Hrib. Gomila I*. Katalog razstave. – Novo mesto.
- KRIŽ, B. 1995, *Novo mesto pred Iliri (Novo mesto vor den Illyrern)*. Katalog razstave. – Novo mesto.
- KRIŽ, B. 1997, *Novo mesto* 4. *Kapiteljska njiva. Gomila II in gomila III*. – *Carniola Archaeologica* 4.
- KRIŽ, B. 2000, *Novo mesto* 5. *Kapiteljska njiva. Gomila IV in gomila V*. – *Carniola Archaeologica* 5.
- KRIŽ, B. 2004, La Slovenia nella tarda età hallstattiana. – V / In: F. Marzatico, P. Gleirscher (ur. / eds.), *Guerriglieri, principi ed eroi fra il Danubio e il Po dalla Preistoria all'Alto Medioevo*, Trento, 421–427.
- KRIŽ, B. 2005, *Novo mesto* 6. *Kapiteljska njiva. Mlajšeželeznodobno grobišče (Late Iron Age Cemetery)*. – *Carniola Archaeologica* 6.
- KRIŽ, B., P. TURK 2003, *Steklo in jantar Novega mesta*. Katalog arheološke razstave. – Novo mesto-Ljubljana.
- KRIŽ, B., P. STIPANČIČ, A. ŠKEDELJ-PETRIČ 2009, *Arheološka podoba Dolenjske*. Katalog stalne arheološke razstave Dolenjskega muzeja Novo mesto (*The archaeological image of Dolenjska*. Catalogue of the permanent archaeological exhibition at the Dolenjski muzej Novo mesto). – Novo mesto.
- KROMER, K. 1959a, *Brezje*. – *Arheološki katalogi Slovenije* 2.
- KROMER, K. 1959b, *Das Gräberfeld von Hallstatt*. – Firenze.
- KROMER, K. 1986, Das östliche Mitteleuropa in der frühen Eisenzeit (7.–5. Jh. v. Chr.) – seine Beziehungen zu den Steppenvölkern und antiken Hochkulturen. – *Jahrbuch des Römisch-Germanischen Zentralmuseums Mainz* 33/1, 1–93.
- KROMER, K., S. GABROVEC 1962, L'art des sépultures hallstattiennes en Slovénie. – V / In: *Inventaria Archaeologica* 5, Y 41–46.
- KRUH, A. 2008, Gomila 5 ali Tratarjeva gomila (Grabhügel 5 oder Tratar-Grabhügel). – V / In: S. Gabrovec, B. Teržan, *Stična II/2. Gomile starejše železne dobe. Razprave (Grabhügel aus der älteren Eisenzeit. Studien)*, Katalogi in monografije 38 (2010), 69–131.
- KRUTA POPPI, L. 1995, Il torques in Cisalpina: tradizioni indigene e apporto celtico. – V / In: J.-J. Charpy (ur. / ed.), *L'Europe celtique du V^e au III^e siècle avant J.-C.: Contacts, échanges et mouvements de populations*. Actes du deuxième symposium international d'Hautvillers 8–10 octobre 1992, Sceaux, 293–308.
- KULL, B. 1997, Tod und Apotheose. Zur Ikonographie in Grab und Kunst der jüngeren Eisenzeit an der unteren Donau und ihre Bedeutung für die Interpretation von

- "Prunkgräbern". – *Bericht der Römisch-Germanischen Kommission* 78, 197–466.
- KUNTER, K. 1995, *Glasperlen der vorrömischen Eisenzeit. Schichtaugenperlen. Nach Unterlagen von Th. E. Haevernick* 4. – Marburger Studien zur Vor- und Frühgeschichte 18.
- LACAM, J.-C. 2008, Le sacrifice du chien dans les communautés grecques, étrusques, italiques et romaines: approche comparatiste. – *Mélanges de l'École française de Rome. Antiquité* 120/1, 29–80.
- LANG, A., V. SALAC (ur. / eds.) 2002, *Fernkontakte in der Eisenzeit. Dálkové kontakty v době železné*. Konferenz Liblice 2000. – Praha.
- LAZAR, T. 2011, Borilna tehnika halštatskodobnih boksarjev: poskus ponovne interpretacije situlskih upodobitev (The fighting techniques of the Hallstatt period boxers: an attempt at reinterpretation of the situla art). – *Arheološki vestnik* 62, 263–288.
- LANTIER, R. 1934, The cemetery of Magdalenska gora (Magdalenaberg bei St. Marein) in Carniola. – V / In: A. Mahr (ur. / ed.), *Prehistoric Grave Material from Carniola excavated in 1905–14 by H. H. the late Duchess Paul Friederich of Mecklenburg*, New York, 39–46, 73–85.
- LEONARDI, G., M. CUPITÓ 2011, Necropoli "a tumuli" e "ad accumuli stratificati" nella preistoria e protostoria del Veneto. – V / In: A. Naso (ur. / ed.), *Tumuli e sepolture monumentali nella protostoria europea*. Atti del convegno internazionale, Celano, 21–24 settembre 2000, Römisch-Germanisches Zentralmuseum – Tagungen 5, 13–49.
- LOLLINI, D. G. 1976, Sintesi della civiltà picena. – V / In: *Jadranska obala u protohistoriji. Kulturni i Etnički problemi*, Zagreb, 117–153.
- LORENZ, H. 1978, Totenbrauchtum und Tracht. Untersuchungen zur regionalen Gliederung in der frühen Latènezeit. – *Bericht der Römisch-Germanischen Kommission* 59, 1–382.
- LORENZ, H. 1980, Bemerkungen zur Totenbrauchtum. – V / In: L. Pauli (ur. / ed.), *Die Kelten in Mitteleuropa: Kultur, Kunst, Wirtschaft*. Salzburger Landesausstellung, 1. Mai–30. Sept. 1980 im Keltenmuseum Hallein Österreich, Salzburg, 138–148.
- LO SCHIAVO, F. 1970, Il gruppo liburnico-japodico. Per una definizione nell'ambito della protostoria balcanica. – *Memorie dell'Accademia dei Lincei* 8/14, 363–523.
- LO SCHIAVO, F. 2010, *Le fibule dell'Italia meridionale e della Sicilia dall'età del bronzo recente al VI secolo a.C.* – *Prähistorische Bronzefunde* XIV/14.
- LOŽAR, R. 1934, Predzgodovina Slovenije, posebej Kranjske, v luči zbirke Mecklenburg (Die Vorgeschichte Sloweniens, insbesondere Krains, im Lichte der Sammlung Mecklenburg). – *Glasičnik Muzejskega društva za Slovenijo* 15, 5–91.
- LOŽNJAK DIZDAR, D. 2009, Grobovi uglednica mlađe faze kulture polja sa žarama u sjevernoj Hrvatskoj. Prilog poznavanju ženske nošnje kasnog brončanog doba na prostoru južne Panonije (Burials of female notables from the younger phase of the Urnfield Culture in Northern Croatia. A contribution to the knowledge of female wear in the Late Bronze Age in Southern Pannonia). – *Vjesnik Arheološkog muzeja u Zagrebu* 3. Ser. 42, 157–182.
- LOŽNJAK DIZDAR, D. 2010, *Sotinska groblja u željeznom dobu. Arheološke spoznaje o Sotinu. Rezultati probnih istraživanja 2008.–2010.* – Zagreb.
- LUCENTINI, N. 1992, Nuove tombe picene a Montedinove. – V / In: M. Dardari (ur. / ed.), *La civiltà picena nelle Marche, Studi in onore di Giovanni Annibaldi*, Ancona, 10–13 luglio 1988, Ripatransone, 464–493.
- LUCENTINI, N. 2007, Riflessi della circolazione adriatica nelle Marche centromeridionali. – V / In: M. Guštin et al. (ur. / eds.), *Piceni ed Europa*, Archeologia di frontiera 6, 95–108.
- LUCKE, W., O.-H. FREY 1962, *Die Situla in Providence (Rhode Island). Ein Beitrag zur Situlenkunst des Osthallstattkreises.* – *Römisch-germanische Forschungen* 26.
- LUNZ, R. 1974, *Studien zur End-Bronzezeit und älteren Eisenzeit im Südalpenraum.* – Origines, Firenze.
- LÜCKE, J. 2007, Das Lappenbeil im mittleren Alpenraum als Motiv in bildlichen und plastischen Darstellungen. – V / In: *Scripta Praehistorica in Honorem Biba Teržan*, Situla 44, 597–612.
- MAGGIANI, A. 2003, Il cavallo (alato e aggiogato) in Etruria. – V / In: G. Cresci Marrone, M. Tirelli (ur. / eds.), *Altinum 3, Produzioni, merci e commerci in Altino preromana e romana*. Atti del Convegno, Venezia, 12–14 dicembre 2001, Studi e ricerche sulla Gallia Cisalpina 17, 161–178.
- MAHR, A. 1934 (ur. / ed.), *Prehistoric Grave Material from Carniola excavated in 1905–14 by H. H. the late Duchess Paul Friedrich of Mecklenburg.* – New York.
- MAJNARIČ-PANDŽIĆ, N. 1999–2000, O pojavi novih tipova konjske opreme iz završnog starijeg železnog doba u istočnoj Hrvatskoj (The appearance of new types of horse equipment from the final Early Iron Age in Eastern Croatia). – *Opuscula Archaeologica* 23/24, 27–38.
- MALNATI, L. 1996, Gli antichi Veneti orientali. – V / In: *La protostoria tra Sile e Tagliamento. Antiche genti tra Veneto e Friuli*, Cataloghi 2, 3–9.
- MALNATI, L. 2004, Il ruolo dell'aristocrazia nell'affermazione del dominio etrusco in Val Padana tra il IX e la fine del VII secolo A.C. – V / In: F. Marzatico, P. Gleirscher (ur. / eds.), *Guerrieri, principi ed eroi fra il Danubio e il Po dalla Preistoria all'Alto Medioevo*, Trento, 249–257.
- MANESSI, P., A. NASCIMBENE 2003, *Montebelluna. Sepolture preromane dalle necropoli di Santa Maria in Colle e Posmon.* – *Archeologia, Quaderni del Museo di Storia naturale e Archeologia di Montebelluna* 1.
- MANICHETTI, M. 2000, Political Forms in the Archaic Period. – V / In: M. Torelli (ur. / ed.), *The Etruscans*, Milano, 205–215.
- MANSFELD, G. 1973, *Die Fibeln der Heuneburg 1950–1970. Ein Beitrag zur Geschichte der Späthallstattfibeln.* – *Römisch-Germanische Forschungen* 33.
- MARCHESETTI, C. 1893, Scavi nella necropoli di S. Lucia presso Tolmino. – *Bollettino della Società adriatica di scienze naturali in Trieste* 15, 1–334.
- MARCHESETTI, C. 1981, *I castellieri preistorici di Trieste e della regione Giulia* (1903). – Società per la preistoria e protostoria della Regione Friuli-Venezia Giulia, Quaderno 3, Trieste.
- MARCHESETTI, C. 1993, *Scritti sulla necropoli di S. Lucia di Tolmino (scavi 1884–1902).* – Trieste.

- MARIĆ, Z. 1964, Donja Dolina. – *Glasnik Zemaljskog muzeja u Sarajevu* n. s. 19, 5–128.
- MARIJAN, B. 1985–1986, Zajednička grobnica željeznog doba iz Vašarovina kod Livna. – *Glasnik Zemaljskog muzeja Bosne i Hercegovine u Sarajevu* n. s. 40/41, 23–38.
- MARINETTI, A. 2003, Il "signore del cavallo" e i riflessi istituzionali dei dati di lingua. Venetico *ekupetaris*. – V / In: G. Cresci Marrone, M. Tirelli (ur. / eds.), *Altinum 3, Produzioni, merci e commerci in Altino preromana e romana*. Atti del Convegno, Venezia, 12–14 dicembre 2001, Studi e ricerche sulla Gallia Cisalpina 17, 143–160.
- MARZATICO, F. 1999, Apporti etrusco-italici nell'area retica. – V / In: *Protostoria e storia del "Venetorum Angulus"*. Atti del XX Convegno di Studi Etruschi ed Italici, Portogruaro, Quarto d'Altino, Este, Adria, 16–19 ottobre 1996, Pisa-Roma, 475–484.
- MARZATICO, F. 2001, Il Trentino-Alto Adige/Südtirol tra il VI secolo e la romanizzazione. – V / In: S. Vitri, F. Oriolo, *I Celti in Carnia e nell'arco alpino centro orientale*. Atti della Giornata di studio, Tolmezzo 30 aprile 1999, Trieste, 227–243.
- MASTROCINQUE, A. 1987, *Santuari e divinità dei Paleoveneti*. – Padova.
- MASTROCINQUE, A. 1991, *L'ambra e l'Eridano: Studi sulla letteratura a sul commercio dell'ambra in età preromana*. – Este.
- MASTROCINQUE, A. 1999, Le ambre di Frattesina. – V / In: *Protostoria e storia del "Venetorum Angulus"*. Atti del XX Convegno di Studi Etruschi ed Italici, Portogruaro, Quarto d'Altino, Este, Adria, 16–19 ottobre 1996, Pisa-Roma, 227–234.
- MAUTENDORFER, H. 2005, Genähtes aus dem prähistorischen Hallstatt. – V / In: P. Bichler et al. (ur. / eds.), *Hallstatt textiles. Technical analysis, scientific investigation and experiment on Iron Age textiles*, BAR. International series 1351, 41–54.
- MAYER, E. F. 1977, *Die Äxte und Beile in Österreich*. – Prähistorische Bronzefunde IX/9.
- METCALF, P., R. HUNTINGTON 1985, *Celebrations of death. The anthropology of mortuary ritual*. – Cambridge.
- METZNER-NEBELSICK, C. 1996, Die Urnenfelder- und Hallstattzeit in Südostpannonien – eine Region im Spannungsfeld zwischen Osthallstattkreis, karpatenländisch-balkanischer Eisenzeit und Steppenkultur. – V / In: E. Jerem, A. Lippert (ur. / eds.), *Osthallstattkultur*. Akten des Internationalen Symposiums, Sopron, 10.–14. Mai 1994, *Archaeolingua* 7, 283–314.
- METZNER-NEBELSICK, C. 2007, Pferdchenfibeln. Zur Deutung einer frauenspezifischen Schmuckform der Hallstatt- und Frühlatènezeit. – V / In: *Scripta Praehistorica in Honorem Biba Teržan*, Situla 44, 707–735.
- MIHOVILIĆ, K. 1988, *Histri i Etruščani (Histrians and Etruscans)*. – Monografije i katalozi 5.
- MIHOVILIĆ, K. 1995, Reichtum durch Handel in der Hallstattzeit Istrien. – V / In: B. Hänsel (ur. / ed.), *Handel, Tausch und Verkehr im Bronze- und früheisenzeitlichen Südosteuropa*, *Prähistorische Archäologie in Südosteuropa* 11, 283–329.
- MIHOVILIĆ, K. 2001, *Nezakcij: prapovijesni nalazi 1900.–1953. (Nesactium: prehistoric finds 1900–1953)*. – Monografije i katalozi 11.

- MLINAR, M. 2009, About three Iron Age finds, excavated in the year 1927 at Most na Soči. – V / In: G. Tiefengraber, B. Kavur, A. Gaspari (ur. / eds.), *Keltske študije 2 (Studies in Celtic Archaeology)*, *Papers in honour of Mitja Guštin*, *Protohistoire Européenne* 11, 217–223.
- MOOSLEITNER, F. 1992, *Das hallstattzeitliche Gräberfeld von Uttendorf im Pinzgau*. – Salzburg.
- MORELLI, C. 2001, La necropoli arcaica di Val Fondillo a Opi. – V / In: *Eroi e Regine: Piceni Popolo d'Europa*, Roma, 326–331.
- MOSER, S. 2009, Ein Negauerhelm vom Dürrnberg bei Hallein. Vorbericht zur Grabung des ÖFD 2008. – V / In: G. Tiefengraber, B. Kavur, A. Gaspari (ur. / eds.), *Keltske študije 2 (Studies in Celtic Archaeology)*, *Papers in honour of Mitja Guštin*, *Protohistoire Européenne* 11, 101–106.
- MÜLLER-KARPE, H. 1953, Zum Beginn der Kahnfibeln mit profiliertem Fuss (Pojav čolničaste fibule s profilirano nogu). – *Arheološki vestnik* 4, 54–58.
- MÜLLER-KARPE, H. 1959, *Beiträge zur Chronologie der Urnenfelderzeit nördlich und südlich der Alpen*. – Römisch-Germanische Forschungen 22.
- NAGY, M. 2011, Ikevár, Pinkóci-dűlőtől északra (Ikevár, nördlich der Pinkóci-Flur). – V / In: *Űjabb eredmények Vas megye őskorának kutatásában (Zeitschncke: neue Forschungsergebnisse zur Vorgeschichte vom Komitat Vas)*, *Időcsiga* 3, 166–168.
- NASCIMBENE, A. 2009, *Le Alpi Orientali nell'età del ferro (VII-V) secolo a. C.* – Collana "L'Album" 15.
- NASO, A. 2007, La cultura orientalizzante nel Piceno: caratteri propri e influssi esterni. – V / In: M. Guštin et al. (ur. / eds.), *Piceni ed Europa*, *Archeologia di frontiera* 6, 21–28.
- NASO, A. (ur. / ed.) 2011, *Tumuli e sepolture monumentali nella protostoria europea*. Atti del convegno internazionale, Celano, 21–24 settembre 2000. Römisch-Germanisches Zentralmuseum – Tagungen 5.
- NEGRONI CATAACCHIO, N. 1984a, La problematica dell'ambra nella protostoria italiana: le ambre intagliate di Fratta Polesine e le rotte mercantili nell'Alto Adriatico. – *Padusa* 20, 73–90.
- NEGRONI CATAACCHIO, N. 1984b, La problematica dell'ambra nella protostoria italiana: ancora sulle ambre di Frattesina di Fratta Polesine. – *Padusa* 20, 141–153.
- NEGRONI CATAACCHIO, N. 1999, Produzione e commercio dei vaghi d'ambra tipo Tirinto e tipo Allumiere alla luce delle recenti scoperte. – V / In: *Protostoria e storia del "Venetorum Angulus"*. Atti del XX Convegno di Studi Etruschi ed Italici, Portogruaro, Quarto d'Altino, Este, Adria, 16–19 ottobre 1996, Pisa-Roma, 241–166.
- NEGRONI CATAACCHIO, N. 2003, Le ambre picene. Indagini sui manufatti non figurati e contatti e scambi con le aree adriatiche. – V / In: *I Piceni e l'Italia medio-adriatica*. Atti del XXII Convegno di studi etruschi ed italici, Ascoli Piceno, Teramo, Ancona, 9–13 aprile 2000, Pisa-Roma, 451–470.
- NEGRONI CATAACCHIO, N. 2007, Le vesti sontuose e gli ornamenti. Monili d'ambra e di materie preziose nelle tombe femminili di età orientalizzante e arcaica in Italia. – V / In: *Scripta Praehistorica in Honorem Biba Teržan*, Situla 44, 533–556.

- OEFITIGER, C. 1984, *Merfachbestattungen im Westhallstattkreis. Zum Problem der Totenfolge*. – Antiquitas Reihe 3, Band 26.
- OGRIN, M. 1998, Trortasta fibula v Sloveniji (Die Dreiknopffibel in Slowenien). – *Arheološki vestnik* 49, 101–132.
- ORTALLI, J. 1995, La necropoli celtica della zona "A" di Casalecchio di Reno (Bologna). Note preliminari sullo scavo del complesso sepolcrale e dell'area di culto. – V / In: J.-J. Charpy (ur. / ed.), *L'Europe celtique du V^e au III^e siècle avant J.-C. Contacts, échanges et mouvements de populations*. Actes du deuxième symposium international d'Hautvillers 8–10 octobre 1992, Sceaux, 189–238.
- OSBORNE, R. 2004, Law, the democratic citizen and representation of women in classical Athens. – V / In: R. Osborne (ur. / ed.), *Studies in ancient Greek and Roman society*, Cambridge-New York, 38–55.
- PAHIČ, S. 1972, *Pobrežje*. – Katalogi in monografije 6.
- PALAVESTRA, A. 1993, *Praistorijski čilibar na centralnom i zapadnom Balkanu (Prehistoric amber in Central and Western Balkans)*. – Balkanološki institut, Posebna izdanja 52.
- PALAVESTRA, A., V. KRSTIĆ 2006, *The magic of amber*. – Archaeological monographies 18.
- PÁRDUCZ, M. 1973, Probleme der Skythenzeit im Karpatenbecken. – *Acta Archaeologica Academiae Scientiarum Hungaricae* 25, 27–64.
- PARE, Ch. F. E. 1989, Ein zweites Fürstengrab von Apremont – "La Motte aux Féés" (Arr. Vesoul, Dép. Haute-Saône). Untersuchungen zur Späthallstattkultur im ostfranzösischen Raum. – *Jahrbuch des Römisch-Germanischen Zentralmuseums Mainz* 36/2, 411–472.
- PARZINGER, H. 1988, *Chronologie der Späthallstatt- und Frühlatène-Zeit. Studien zu Fundgruppen zwischen Mosel und Save*. – Quellen und Forschungen zur prähistorischen und provinzialrömischen Archäologie 4.
- PARZINGER, H. 1988–1989, Hallstattzeitliche Grabhügel bei Dobrníč. – *Arheološki vestnik* 39/40, 529–635.
- PARZINGER, H., S. STEGMANN-RAJTÁR 1988, Smolenice-Molpir und der Beginn skythischer Sachkultur in der Südwestslowakei. – *Praehistorische Zeitschrift* 63, 162–178.
- PARZINGER, H., J. NEKVASIL, F. E. BARTH 1995, *Die Býčí skála-Höhle. Ein hallstattzeitlicher Höhlenopferplatz in Mähren*. – Römisch-Germanische Forschungen 54.
- PAULI, L. 1966, Ein hallstattzeitliches Hügelgrab mit Pferdegeschirr bei Burggriesbach, Ldkr. Beilngries. – *Bayerische Vorgeschichtsblätter* 31, 68–79.
- PAULI, L. 1971, *Studien zur Golasecca-Kultur*. – Mitteilungen des Deutschen Archaeologischen Instituts = Bulletin dell'Istituto archeologico germanico. Supplemento 19.
- PAULI, L. 1975, *Keltischer Volksglaube. Amulette und Sonderbestattungen am Dürrnberg bei Hallein und im eisenzeitlichen Mitteleuropa*. – Münchner Beiträge zur Vor- und Frühgeschichte 28.
- PAULI, L. 1978, *Der Dürrnberg bei Hallein 3. Auswertung der Grabfunde*. – Münchner Beiträge zur Vor- und Frühgeschichte 18.
- PAULI, L. 1980, Das keltische Mitteleuropa vom 6. bis zum 2. Jahrhundert v.Chr. – V / In: L. Pauli (ur. / ed.), *Die Kelten in Mitteleuropa: Kultur, Kunst, Wirtschaft*. Salz-

- burger Landesausstellung, 1. Mai–30. Sept. 1980 im Keltenmuseum Hallein Österreich, Salzburg, 25–37.
- PAULI, L. 1984, Die Wagengräber auf dem Dürrnberg bei Hallein (Österreich). – V / In: M. Guštin, L. Pauli (ur. / eds.), *Keltski voz*, Posavski muzej Brežice 6, 89–97.
- PAULI, L. 1991, I passi alpini e la migrazioni celtiche. – V / In: Sabatino Moscati et al. (ur. / eds.), *I Celti*, Milano, 215–235.
- PAULI, L. 1992, Die historische Entwicklung im Gebiet der Golasecca-Kultur. – V / In: L. Aigner-Foresti (ur. / ed.), *Etrusker nördlich von Etrurien*, Österreichische Akademie der Wissenschaften, Philosophisch-historische Klasse, Sitzungsberichte 589, 179–196.
- PEČNIK, J. 1893, Najnovejše izkopine z Gore pri Šmariji. – *Izvestja Muzejskega društva za Kranjsko* 3, 41–47.
- PERONI, R., G. L. CARANCHINI, P. CORETTI IRDI, L. PONZI BONOMI, A. RALLO, P. SARONIO MASOLO, F. R. SERRA RIDGWAY 1975, *Studi sulla cronologia delle civiltà di Este e Golasecca*. – Origines, Firenze.
- PETTARIN, S. 2006, *Le necropoli di San Pietro al Natisone e Dernazzacco. Nella documentazione del Museo Archeologico Nazionale di Cividale del Friuli*. – Studi e ricerche di protostoria mediterranea 7.
- PLETERSKI, A. 2008, *Zgodnjesrednjeveška naselbina na blejski Pristavi: najdbe (Frühmittelalterliche Siedlung Pristava in Bled: Funde)*. – Opera Instituti Archaeologici Sloveniae 14.
- POLIZZOTTI GREIS, G. 2006, *A Noble Pursuit. The Duchess of Mecklenburg Collection from Iron Age Slovenia*. – Cambridge, Massachusetts.
- PRELOŽNIK, A. 2007a, Fibule picene e lucane nel Caput Adriae orientale. – V / In: M. Guštin et al. (ur. / eds.), *Piceni ed Europa*, Archeologia di frontiera 6, 123–134.
- PRELOŽNIK, A. 2007b, Steppenreiterspuren im eisenzeitlichen Dolenjsko (Slowenien). – V / In: F. M. Andraschko et al. (ur. / eds.), *Archäologie zwischen Befund und Rekonstruktion: Ansprache und Anschaulichkeit, Festschrift für Prof. Dr. Renate Rolle zum 65. Geburtstag*, Antiquitates 39, 155–167.
- PRIMAS, M. 2007, Spinnwirtel im Grab – zum Symbolgehalt einer Beigabe. – V / In: *Scripta Praehistorica in Honorem Biba Teržan*, Situla 44, 301–312.
- PROSDOCIMI, A. L. 2003, Sul sacrificio del cavallo in alcune fonti di tradizioni indoeuropee. – V / In: G. Cresci Marrone, M. Tirelli (ur. / eds.), *Altinum 3, Produzioni, merci e commerci in Altino preromana e romana*. Atti del Convegno, Venezia, 12–14 dicembre 2001, Studi e ricerche sulla Gallia Cisalpina 17, 61–88.
- LA PROTOSTORIA tra Sile e Tagliamento. *Antiche genti tra Veneto e Friuli* 1996. – Cataloghi 2.
- PUŠ, I. 1971, *Žarnogrobiščna nekropola na dvorišču SAZU v Ljubljani. Izkopavanja v letih 1964–1965 (Nekropole der Urnenfelderkultur im Hof der Slowenischen Akademie der Wissenschaften und Künste in Ljubljana. Ausgrabungen in den Jahren 1964–1965)*. – Razprave 1. razreda SAZU 7/1.
- PUŠ, I. 1973, Pomen ljubljanskega prostora v starejši železni dobi (The Significance of the Ljubljana Region in the Early Iron Age). – *Arheološki vestnik* 24 (1975), 386–396.

- PUŠ, I. 1982, *Prazgodovinsko žarno grobišče v Ljubljani (Das vorgeschichtliche Gräberfeld in Ljubljana)*. – Razprave 1. razreda SAZU 13/2.
- PUŠ, I. 1984, Prazgodovinski Molnik (Das vorgeschichtliche Molnik). – *Arheološki vestnik* 35, 134–162.
- PUŠ, I. 1991, *Molnik, sedež prazgodovinskih knezov*. – Ljubljana.
- RADCLIFFE-BROWN, A. R. 1994, *Struktura in funkcija v primitivni družbi*. – *Studia humanitatis*, Ljubljana (= Radcliffe-Brown, A. R., *Structure and function in primitive society: essays and addresses, 1952, 1956*, Glencoe-New York).
- RALLO, A. 2000, The woman's role. – V / In: M. Torelli (ur. / ed.), *The Etruscans*, Milano, 131–139.
- RAMŠAK, A. 2009, Gomile starejše železne dobe na Godeško-Reteških dobravah pri Škofji Loki (Early Iron Age tumuli at Godeško-Reteške dobrave near Škofja Loka). – *Arheološki vestnik* 60, 33–61.
- RENFREW, C. (ur. / ed.) 1984, *Approaches to social archaeology*. – Edinburgh.
- RENFREW, C., S. SHENNAN (ur. / eds.) 2009, *Ranking, resource and exchange. Aspect of the archaeology of early European society*. – London.
- RENFREW, C., M. J. ROWLANDS, B. ABBOT SEGRAVES (ur. / eds.) 1982, *Theory and Explanation in Archaeology*. – New York.
- RIGHI, G. 2001, I rinvenimenti lateniani di Amaro e di Monte Sorantri a Raveo. – V / In: S. Vitri, F. Oriolo (ur. / eds.), *I Celti in Carnia e nell'arco alpino centro orientale*. Atti della Giornata di studio, Tolmezzo 30 aprile 1999, Trieste, 113–148.
- ŘÍHOVSKÝ, J. 1992, *Die Äxte, Beile, Meißel und Hämmer in Mähren*. – *Prähistorische Bronzefunde IX/17*.
- RUARO LOSERI, L., G. STEFFÈ DE PIERO, S. VITRI, G. RIGHI. 1977, *La necropoli di Brežec presso S. Canziano del Carso: scavi Marchesetti 1896–1900*. – Atti dei Civici Musei di Storia ed Arte di Trieste. Monografie di preistoria 1.
- RUTA SERAFINI, A. 2001, Il celtismo in area veneta. Nuovi dati. – V / In: S. Vitri, F. Oriolo (ur. / eds.), *I Celti in Carnia e nell'arco alpino centro orientale*. Atti della Giornata di studio, Tolmezzo 30 aprile 1999, Trieste, 197–210.
- RUTAR, S. 1893a, Gradišče in gomile na gori sv. Magdalene pri Šmariji. – *Izvestja Muzejskega društva za Kranjsko* 3, 1–6.
- RUTAR, S. 1893b, Najnovejše prazgodovinske najdbe pri Sv. Magdaleni. – *Izvestja Muzejskega društva za Kranjsko* 3, 35–36.
- RUTAR, S. 1893c, Starinske najdbe na Magdalenski Gori. – *Izvestja Muzejskega društva za Kranjsko* 3, 207–208.
- RUTAR, S. 1893d, Razkopavanje na Magdalenski Gori. – *Izvestja Muzejskega društva za Kranjsko* 3, 252–253.
- RUTAR, S. 1894, Die Grabungen in Krain während des Jahres 1893. – *Mittheilungen der k.k. Central-Commission* N. F. 20, 183–184.
- RUTAR, S. 1895, Der Magdalenberg bei St. Marein unterhalb Laibach. – *Mittheilungen der k.k. Central-Commission* N. F. 21, 39–40.
- RUTAR, S., J. PEČNIK 1894, Prazgodovinske najdbe na Kranjskem I. 1894. – *Izvestja Muzejskega društva za Kranjsko* 4, 78.
- SABBATINI, T. 2003, Le necropoli orientalizzanti di Fabriano: nuovi contributi. – V / In: *I Piceni e l'Italia medio-adriatica*. Atti del XXII Convegno di studi etruschi ed italici, Ascoli Piceno, Teramo, Ancona, 9–13 aprile 2000, Pisa-Roma, 181–210.
- SALARI, L., R. SARDELLA, E. SQUAZZINI, A. LISCIARELLI, T. SUADONI 2006, Il cane della necropoli di Amelia (Terni, Umbria). – V / In: A. Curci, D. Vitali (ur. / eds.), *Animali tra uomini e dei. Archeozoologia del mondo preromano*. Atti del Convegno Internazionale 8–9 novembre 2002, Studi e Scavi n. s. 14, 179–191.
- SASSATELLI, G. 1999, Nuovi dati epigrafici e ruolo della vale del Piave: aspetti culturali e cultuali. – V / In: *Protostoria e storia del "Venetorum Angulus"*. Atti del XX Convegno di Studi Etruschi ed Italici, Portogruaro, Quarto d'Altino, Este, Adria, 16–19 ottobre 1996, Pisa-Roma, 453–474.
- SASSATELLI, G. 2000, The Etruscan Expansion in the Po Valley. – V / In: M. Torelli (ur. / ed.), *The Etruscans*, Milano, 169–179.
- SASSATELLI, G. 2004, Gli Etruschi nella valle del Po: Il nuovo potere "cittadino" e i magistrati. – V / In: F. Marzatico, P. Gleirscher (ur. / eds.), *Guerriglieri, principi ed eroi fra il Danubio e il Po dalla Preistoria all'Alto Medioevo*, Trento, 263–275.
- SCHAUER, P. 1995, Stand und Aufgaben der Urnenfelderforschung in Süddeutschland. – V / In: *Beiträge zur Urnenfelderzeit nördlich und südlich der Alpen*, Römisch-Germanisches Zentralmuseum, Monographien 35, 121–200.
- SEAFORD, R. 2004, Reciprocity and ritual: Homer and tragedy in the developing city-state. – V / In: R. Osborne (ur. / ed.), *Studies in ancient Greek and Roman society*, Cambridge-New York, 56–60.
- SEGAL BRANDFORD, J. 1978, The Textiles. – V / In: H. Hencken, *The Iron Age Cemetery of Magdalenska gora in Slovenia*. Mecklenburg Collection Part 2, American School of Prehistoric Research, Bulletin 32, 301–310.
- SGUBINI MORETTI, A. M. 1992, Pitino. Necropoli di Monte Penna: Tomba 31. – V / In: M. Dardari (ur. / ed.), *La civiltà picena nelle Marche* (Studi in onore di Giovanni Annibaldi), Ancona, 10–13 luglio 1988, Ripatransone, 178–203.
- SIEVERS, S. 1984, *Die Kleinfunde der Heuneburg*. Die Funde aus den Grabungen von 1950–1979. – *Römisch-Germanische Forschungen* 42.
- SMOLNIK, R. 1994, *Der Burgstallkogel bei Kleinklein 2. Die Keramik der vorgeschichtlichen Siedlung*. – Veröffentlichung des Vorgeschichtlichen Seminars Marburg 9.
- SNODGRASS, A. M. 1967, *Arms and Armour of the Greeks*. – London-Southampton.
- SPARKES, B. 2011, *Greek art*. – Cambridge.
- SPINDLER, K. 1973, Die Ausgrabungen am Magdalenberg bei Villingen in Schwarzwald (Magdalenberg bei Villingenu (Schwarzwald)). – *Arheološki vestnik* 24 (1975), 637–659.
- SPINDLER, K. 1978, Ein hallstädtischer Gürtelhaken in Museum Nürnberg (Halštatska pasna spona v Nürnberškem muzeju). – *Arheološki vestnik* 29, 95–99.
- SPITZER, G. 1973, Ein hallstattzeitlicher Tumulus von Dragatuš (Halštatska gomila iz Dragatuša). – *Arheološki vestnik* 24 (1975), 780–830.

- STADLER, J. 2010, *Nahrung für die Toten? Speisebeigaben in hallstattzeitlichen Gräbern und ihre kulturhistorische Deutung*. – Universitätsforschungen zur prähistorischen Archäologie 186.
- STARE, F. 1952, Dekoracija pravokotnih pasnih spon na Kranjskem (Dekoration rechteckiger Gürtelschnallen aus Krain). – *Arheološki vestnik* 3, 173–213.
- STARE, F. 1953, Trije prazgodovinski grobovi iz Zasavja (Drei vorgeschichtliche Gräber aus dem Save-Anraingebiet). – *Arheološki vestnik* 4, 264–281.
- STARE, F. 1954a, *Prazgodovinske Vače (Das urgeschichtliche Vače)*. – Ljubljana.
- STARE, F. 1954b, *Ilirske najdbe železne dobe v Ljubljani (Illyrische Funde aus der Eisenzeit in Ljubljana)*. – Dela 1. razreda SAZU 9.
- STARE, F. 1954c, K problemu najstarejših čolničastih fibul iz Slovenije (Zu dem Problem der ältesten Kahnfibeln aus Slowenien). – *Arheološki vestnik* 5, 22–49.
- STARE, F. 1954d, Dva ilirska grobova iz Kranja (Zwei illyrische Gräber aus Kranj). – *Arheološki vestnik* 5, 112–122.
- STARE, F. 1955a, *Vače*. – Arheološki katalogi Slovenije 1.
- STARE, F. 1955b, Dva nova prazgodovinska grobova z Vač (Two more prehistoric burials at Vače). – *Arheološki vestnik* 6, 287–290.
- STARE, F. 1955c, Prazgodovinske kovinske posode iz Slovenije. – *Zbornik filozofske fakultete* 2, 103–228.
- STARE, F. 1960, Grob 108 iz Dobove (Grab 108 aus Dobova). – *Situla* 1, 81–98.
- STARE, F. 1962–1963, Kipec ilirskega bojvnika z Vač (Statuette eines illyrischen Kriegers aus Vače). – *Arheološki vestnik* 13/14, 383–434.
- STARE, F. 1975, *Dobova*. – Posavski muzej Brežice 2.
- STARE, F., S. ŠKALER 1958–1959, Brezje pri Raki. – *Varstvo spomenikov* 7, 323.
- STARE, V. 1960–1961, Prazgodovinske Malence (The Prehistoric Malence). – *Arheološki vestnik* 11/12, 50–87.
- STARE, V. 1962–1963, Prazgodovinske gomile iz Rovišča (Die urzeitlichen Hügelgräber aus Rovišče). – *Arheološki vestnik* 13/14, 435–467.
- STARE, V. 1964–1965, Železnodobne gomile na Vinkovem vrhu (Eisenzeitliche Grabhügel auf Vinkov vrh). – *Arheološki vestnik* 15/16, 215–257.
- STARE, V. 1973a, *Prazgodovina Šmarjete (Der vorgeschichtliche Komplex von Šmarjeta)*. – Katalogi in monografije 10.
- STARE, V. 1973b, Gomile pod Koriti na Dolenjskem (Hügelgräber bei Korita in Dolenjsko (Unterkrain)). – *Arheološki vestnik* 24 (1975), 744–779.
- STARE, V. 1973c, Kultne palice iz Šmarjete (Kultstäbe aus Šmarjeta). – *Arheološki vestnik* 24 (1975), 730–743.
- STARE, V. 1976, Časovna opredelitev čolničastih fibul iz Šmarjete (Détermination chronologique des fibules naviculaires de Šmarjeta). – *Arheološki vestnik* 27, 97–119.
- STARE, V. 1978, Fibule z oblogo iz gomil pod Vinjim vrhom (Bügelfibeln aus den Grabhügel unter Vinji vrh). – *Arheološki vestnik* 29, 64–84.
- STARE, V. 1994, Osteološki depo Narodnega muzeja. – *Argo* 36/37, 69–74.
- STARY, P. 1979, Feuerböcke und Bratspieße aus eisenzeitlichen Gräbern der Apennin-Halbinsel. – *Kleine Schriften aus dem Vorgeschichtlichen Seminar Marburg* 5, 40–61.
- STARY, P. 1981, *Zur eisenzeitlichen Bewaffnung und Kampfesweise in Mittelitalien (ca. 9. bis 6. Jh. v. Chr.)*. – Marburger Studien Zur Vor- und Frühgeschichte 3.
- STARY, P. 1982, Zur hallstattzeitlichen Beilbewaffnung des circum-alpinen Raumes. – *Bericht der Römisch-Germanischen Kommission* 63, 17–104.
- STEINER, H. 1999, “Kännchen mit Stierkopfenkel” der Frintzens-Sanzeno-Kultur. – *Archäologisches Korrespondenzblatt* 29/1, 79–92.
- STJERNQUIST, B. 1967, *Ciste a Cordoni*. – *Acta Archaeologica Lundensia* 4/6.
- STJERNQUIST, B. 1988, Die Rippenciste. – V / In: W. Kimmig, *Das Kleinaspergle. Studien zu einem Fürstengrabhügel der frühen Latènezeit bei Stuttgart*, Stuttgart, 161–175.
- STRMČNIK GULIČ, M. 1979, Prazgodovinske gomile na Legnu pri Slovenj Gradcu (Vorgeschichtliche Grabhügel auf dem Legen). – *Arheološki vestnik* 30, 101–150.
- SVOLJŠAK, D. 1973, Prazgodovinsko grobišče v Tolminu (Necropoli preistorica di Tolmin). – *Arheološki vestnik* 24 (1975), 397–417.
- SVOLJŠAK, D., POGAČNIK, A. 2001, *Tolmin, prazgodovinsko grobišče 1. Katalog (Tolmin, the prehistoric cemetery 1. Catalogue)*. – Katalogi in monografije 34.
- SVOLJŠAK, D., POGAČNIK, A. 2002, *Tolmin, prazgodovinsko grobišče 2. Razprave (Tolmin, the prehistoric cemetery 2. Treatises)*. – Katalogi in monografije 35.
- SZOMBATHY, J. 1894, Neue figural verzierte Gürtelbleche aus Krain. – *Mittheilungen der anthropologischen Gesellschaft in Wien* 24, 226–231.
- ŠAŠEL KOS, M. 1999, *Pre-Roman divinities of the eastern Alps and Adriatic*. – *Situla* 38.
- ŠAŠEL KOS, M. 2005, *Appian and Illyricum*. – *Situla* 43.
- ŠAŠEL KOS, M. 2006, A Few Remarks Concerning the archaeologia of Nauportus and Emona: The Argonauts (Argonavti: mitična preteklost Navporta in Emone). – V / In: M. Kokole et al. (ur. / eds.), *Mediterranean myths from classical antiquity to the eighteenth century (Mediterranski miti od antike do 18. stoletja)*, Ljubljana, 13–20.
- ŠAŠEL KOS, M. 2009, Reka kot božanstvo. Sava v antiki. – V / In: *Ukročena lepota. Sava in njene zgodbe*, Sevnica, 42–50.
- ŠINKOVEC, I. 1995, Katalog posameznih kovinskih najdb bakrene in bronaste dobe (Catalogue of Individual Metal Finds from the Eneolithic and Bronze Age). – V / In: B. Teržan (ur. / ed.), *Depojske in posamezne kovinske najdbe bakrene in bronaste dobe na Slovenskem 1 (Hoards and Individual Metal Finds from the Eneolithic and Bronze Ages in Slovenia 1)*, Katalogi in monografije 29, 29–127.
- ŠINKOVEC, I. 1996, Katalog posameznih kovinskih najdb bakrene in bronaste dobe (Catalogue of Individual Metal Finds from the Eneolithic and Bronze Age). – V / In: B. Teržan (ur. / ed.), *Depojske in posamezne kovinske najdbe bakrene in bronaste dobe na Slovenskem 2 (Hoards and Individual Metal Finds from the Eneolithic and Bronze Ages in Slovenia 2)*, Katalogi in monografije 30, 125–163.
- ŠKOBERNE, Ž. 1999, *Budinjak: kneževski tumul (Budinjak, Princely Tumulus)*. – Zagreb.
- ŠKOBERNE, Ž. 2002, Pregled pretpovijesnih arheoloških istraživanja u Žumberku (A Review of Prehistoric

- Archaeological Research at Žumberak). – V / In: *Žumberak – od prapovijesti do kasne antike*, Zagreb, 32–81.
- ŠKVOR JERNEJČIĆ, B. 2011, Starejšezelznodobno grobišče Veliki Nerajec pri Dragatušu v Beli krajini (The Early Iron Age cemetery of Veliki Nerajec near Dragatuš in Bela krajina). – *Arheološki vestnik* 62, 165–230.
- ŠTIBERNIK, G. 2007, Magdalenska gora in okolica v rimski dobi (Magdalenska gora and its surroundings in the Roman Period). – V / In: J. Müller (ur. / ed.), *Šmarska knjiga*, Šmarje-Sap, 91–107.
- ŠVAJNCER, J. J. 2012, Magdalenska gora v Vojnem muzeju Logatec. – *Vojnogodovinski zbornik* 47, 3–11.
- TANKÓ, K. 2005, "Horn-handled" bowls of the Central Europe Iron Age. – V / In: H. Dobrzańska et al. (ur. / eds.), *Celts on the margin. Studies in European Cultural Interaction 7th century BC–1st century AD*, Kraków, 153–162.
- TECCO HVALA, S. 2007, Women from Magdalenska gora. – V / In: *Scripta Praehistorica in Honorem Biba Teržan*, Situla 44, 477–490.
- TECCO HVALA, S., J. DULAR, E. KOCUVAN 2004, *Želznodobne gomile na Magdalenski gori (Eisenzeitliche Grabhügel auf der Magdalenska gora)*. – Katalogi in monografije 36.
- TERŽAN, B. 1973, Valična vas. – *Arheološki vestnik* 24 (1975), 660–729.
- TERŽAN, B. 1974, Halštatske gomile iz Brusnic na Dolenjskem (Die hallstattzeitlichen Grabhügel aus Brusnice bei Novo mesto). – V / In: *Varia archaeologica*, Posavski muzej Brežice 1, 31–66.
- TERŽAN, B. 1976, Certoška fibula (Die Certosafibel). – *Arheološki vestnik* 27 (1977), 317–443.
- TERŽAN, B. 1977, O horizontu bojevnih grobov med Padom in Donavo v 5. in 4. stol. pr. n. št. (Horizon of Warrior Tombs found in the Fifth and Forth Centuries B.C. in the Territory between the Po and the Danube). – V / In: M. Guštin (ur. / ed.), *Keltske študije*, Posavski muzej Brežice 4, 9–21.
- TERŽAN, B. 1978, O halštatski noši na Križni gori (Über das Trachtzubehör auf Križna gora). – *Arheološki vestnik* 29, 55–63.
- TERŽAN, B. 1980, Posodje v grobovih halštatskih veljakov na Dolenjskem (Vessel-sets in the graves of Hallstatt chieftains in the Dolenjska area). – V / In: *Zbornik posvečen Stanetu Gabrovcu ob šestdesetletnici*, Situla 20/21, 343–352.
- TERŽAN, B. 1981, Hugh Hencken, The Iron Age cemetery of Magdalenska gora in Slovenia, Cambridge, Massachusetts, 1978. – *Arheološki vestnik* 32, 659–664.
- TERŽAN, B. 1984a, Nošnja kao obilježje društvenih skupina između Drima i Devolla u starije željezno doba (Roma – Burrel – Kuç i Zi) (Die Tracht als kennzeichnendes Element der ältereisenzeitlichen Gesellschaftsgruppen zwischen Drim und Devoll). – V / In: *Symposium Duhovna kultura Ilira*, Centar za balkanološka ispitivanja, Posebna izdanja 11, 197–214.
- TERŽAN, B. 1984b, O jantarju z Debelega vrha nad Pregradom (The Amber from Debeli vrh above the Village of Pregrad). – *Arheološki vestnik* 35, 110–118.
- TERŽAN, B. 1985, Poskus rekonstrukcije halštatske družbene strukture v dolenskem kulturnem krogu (Ein Rekonstruktionsversuch der Gesellschaftsstruktur im Dolenjsko-Kreis der Hallstattzeit). – *Arheološki vestnik* 36, 77–105.
- TERŽAN, B. 1986, Zur Gesellschaftsstruktur während der älteren Hallstattzeit im Ostalpen – westpannonischen Gebiet. – V / In: L. Török (ur. / ed.), *Hallstatt Kolloquium Veszprém 1984*, Budapest, 227–243.
- TERŽAN, B. 1987, The Early Iron Age chronology of the central Balkans: a review from the viewpoint of the southeastern Alpine Hallstatt. – *Archaeologia Jugoslavica* 24, 7–27.
- TERŽAN, B. 1990a, *Starejša železna doba na Slovenskem Štajerskem (The Early Iron Age in Slovenian Styria)*. – Katalogi in monografije 25.
- TERŽAN, B. 1990b, Polmesečaste fibule. O kulturnih povezavah med Egejo in Caput Adriae (Die Halbmondfibeln. Über die Kulturverbindungen zwischen der Ägäis und dem Caput Adriae). – *Arheološki vestnik* 41, 49–88.
- TERŽAN, B. 1992a, Beobachtungen zu den ältereisenzeitlichen Bestattungssitten im mittleren und südostalpinen Raum. – V / In: I. R. Metzger, P. Gleirscher (ur. / eds.), *Die Räter / I Reti*, Schriftenreihe der Arbeitsgemeinschaft Alpenländer, Bolzano, 451–474.
- TERŽAN, B. 1992b, Bemerkungen zu H. Parzinger Chronologie der Späthallstatt- und Frühlatène-Zeit. – *Praehistorische Zeitschrift* 67, 66–89.
- TERŽAN, B. 1994, Überlegungen zum sozialen Status des Handwerkers in der frühen Eisenzeit Südosteuropas. – V / In: C. Dobiat (ur. / ed.), *Festschrift für Otto-Herman Frey zum 65. Geburtstag*, Marburger Studien zur Vor- und Frühgeschichte 16, 659–669.
- TERŽAN, B. 1995a, Stand und Aufgaben der Forschungen zur Urnenfelderzeit in Jugoslawien. – V / In: *Beiträge zur Urnenfelderzeit nördlich und südlich der Alpen*, Römisch-Germanisches Zentralmuseum, Monographien 35, 323–372.
- TERŽAN, B. 1995b, Handel und soziale Oberschichten im früheisenzeitlichen Südosteuropa. – V / In: B. Hänsel (ur. / ed.), *Handel, Tausch und Verkehr im Bronze- und früheisenzeitlichen Südosteuropa*, Prähistorische Archäologie in Südosteuropa 11, 81–159.
- TERŽAN, B. 1995c, Das Land der Medeia? – V / In: U. Finkbeiner et al. (ur. / eds.), *Beiträge zur Kulturgeschichte Vorderasiens*, Mainz, 627–637.
- TERŽAN, B. 1996a, Sklepná beseda (Conclusion). – V / In: B. Teržan (ur. / ed.), *Depojske in posamezne kovinske najdbe bakrene in bronzaste dobe na Slovenskem 2 (Hoards and Individual Metal Finds from the Eneolithic and Bronze Ages in Slovenia 2)*, Katalogi in monografije 30, 243–258.
- TERŽAN, B. 1996b, Weben und Zeitmessen im südostalpinen und westpannonischen Gebiet. – V / In: E. Jerem, A. Lippert (ur. / eds.), *Osthallstattkultur*. Akten des Internationalen Symposiums, Sopron, 10.–14. Mai 1994, *Archaeolingua* 7, 507–536.
- TERŽAN, B. 1997, Heros der Hallstattzeit: Beobachtungen zum Status an Gräbern um das Caput Adriae. – V / In: C. Becker et al. (ur. / eds.), *Hrónos*, Internationale Archäologie, *Studia honoraria* 1, 653–669.
- TERŽAN, B. 1998, Auswirkungen des skythisch geprägten Kulturkreises auf die hallstattzeitlichen Kulturgruppen Pannoniens und des Ostalpenraumes. – V / In: B. Hänsel,

- J. Machnik (ur. / eds.), *Das Karpatenbecken und die Osteuropäische Steppe*, Südosteuropa-Schriften 20, 511–560.
- TERŽAN, B. 1999, An Outline of the Urnfield Culture Period in Slovenia (Oris obdobja kulture žarnih grobišč na Slovenskem). – *Arheološki vestnik* 50, 97–143.
- TERŽAN, B. 2001a, Richterin und Kriegsgöttin in der Hallstattzeit. Versuch einer Interpretation. – *Prähistorische Zeitschrift* 76, 74–86.
- TERŽAN, B. 2001b, Dolgoživ spomin, Prežitki halštatskega obredja v pustnih šegah na Slovenskem? (A long-lived memory. Can the survival of Hallstatt rituals be seen in carnival celebrations in Slovenia?). – *Arheološki vestnik* 52, 207–219.
- TERŽAN, B. 2002, Kronološki oris (Chronological outline). – V / In: D. Svoljšak, A. Pogačnik, *Tolmin, prazgodovinsko grobišče 2. Razprave (Tolmin, the prehistoric cemetery 2. Treatises)*, Katalogi in monografije 35, 85–102.
- TERŽAN, B. 2003, Goldene Ohringe in der späten Bronzezeit und frühen Eisenzeit – Zeichen des Sakralen? – *Anzeiger des Germanischen Nationalmuseums*, 68–82.
- TERŽAN, B. 2004a, Obolos – mediterrane Vorbilder einer prämonetären “Währung” der Hallstattzeit? – V: Hänsel B. (ur. / ed.), *Parerga prähistorica*, Universitätsforschungen zur prähistorischen Archäologie 100, 161–202.
- TERŽAN, B. 2004b, L'aristocrazia femminile nella prima età del Ferro. – V / In: F. Marzatico, P. Gleirscher (ur. / eds.), *Guerrigieri, principi ed eroi fra il Danubio e il Po dalla Preistoria all'Alto Medioevo*, Trento, 221–229.
- TERŽAN, B. 2005, Metamorphose – eine Vegetationsgottheit in der Spätbronzezeit. – V / In: B. Horejs et al. (ur. / eds.), *Interpretationsraum Bronzezeit*, Universitätsforschungen zur prähistorischen Archäologie 121, 241–261.
- TERŽAN, B. 2006, Pasma spona iz groba 30 gomile VI po vojvodinji Mecklenburški oz. iz gomile 55 (Gürtelblech aus Grab 30, Grabhügel VI nach Herzogin von Mecklenburg bzw. Grabhügel 55). – V / In: Gabrovec et al., *Stična II/1. Gomile starejše železne dobe (Grabhügel aus der älteren Eisenzeit)*, Katalogi in monografije 37, 266–269.
- TERŽAN, B. 2007a, Principi e guerrieri delle due sponde altoadriatiche. – V / In: M. Guštin et al. (ur. / eds.), *Piceni ed Europa*, *Archeologia di frontiera* 6, 39–54.
- TERŽAN, B. 2007b, Pripoved situlske umetnosti z Magdalenske gore pri Šmarju (A narration of Situla art from Magdalenska gora at Šmarje). – V / In: J. Müller (ur. / ed.), *Šmarska knjiga*, Šmarje-Sap, 81–90.
- TERŽAN, B. 2008, Stiške skice (Stična – Skizzen). – V / In: *Stična II/2. Gomile starejše železne dobe. Razprave (Grabhügel aus der älteren Eisenzeit. Studien)*, Katalogi in monografije 38 (2010), 189–325.
- TERŽAN, B. 2009a, Kaukasisches Symbolgut in Südosteuropa: Bemerkungen zu Goldfibeln von Michałków – Fokoru – Dalj. – V / In: *Der Schwarzmeerraum vom Äneolithikum bis in die Frühbronzezeit (5000–500 v. Chr.)*, *Prähistorische Archäologie in Südosteuropa* 25, 190–216.
- TERŽAN, B. 2009b, Japodska nevesta iz okolice Novega mesta (A Iapodian bride from the vicinity of Novo mesto). – *Vjesnik Arheološkog muzeja u Zagrebu* 3. ser. 42, 213–230.
- TERŽAN, B. 2009c, Der geflügelte Löwe aus Hallstatt mit dem Schinken im Rachen. – *Mitteilungen der Anthropologischen Gesellschaft in Wien* 139, 195–201.
- TERŽAN, B. 2009d, Eine latèneartige Fremdform im hallstattischen Vače. – V / In: G. Tiefengraber, B. Kavur, A. Gaspari (ur. / eds.), *Keltske študije 2 (Studies in Celtic Archaeology)*, *Papers in honour of Mitja Guštin*, *Protohistoire Européenne* 11, 85–99.
- TERŽAN, B. 2011a, Hallstatt Europe: Some Aspects of Religion and Social Structure. – V / In: G. R. Tsetschkladze (ur. / ed.), *The Black Sea, Greece, Anatolia and Europe in the First Millennium BC*, Leuven-Paris-Walpole, 233–263.
- TERŽAN, B. 2011b, Horses and cauldrons. Some remarks on horse and chariot races in situla art. – *Notizie archeologiche bergomensi* 19, 303–325.
- TERŽAN, B. 2012, Sfinga v situlski umetnosti ob severnem Jadranu in njegovem zaledju (The sphinx in Situla Art in the northern Adriatic region and its hinterland). – V / In: *Scripta in Honorem Bojan Djurić*, *Monografije CPA* 1, 169–196.
- TERŽAN, B., A. HELLMUTH 2008, Ponovno o zlatem diademu iz Stične (Noch einmal zum goldenen Diadem aus Stična). – V / In: *Stična II/2. Gomile starejše železne dobe. Razprave (Grabhügel aus der älteren Eisenzeit. Studien)*, Katalogi in monografije 38 (2010), 173–325.
- TERŽAN, B., N. TRAMPUŽ 1973, Prispevek hkronologiji svetolucijske skupine (Contributo alla cronologia del gruppo preistorico di Santa Lucia). – *Arheološki vestnik* 24 (1975), 660–460.
- TERŽAN, B., F. LO SCHIAVO, N. TRAMPUŽ-OREL 1984, *Most na Soči (S. Lucia) 2. Szombathyjeva izkopavanja – Table (Die Ausgrabungen von J. Szombathy – Tafelband)*. – Katalogi in monografije 23/2.
- TERŽAN, B., F. LO SCHIAVO, N. TRAMPUŽ-OREL 1985, *Most na Soči (S. Lucia) 2. Szombathyjeva izkopavanja – Tekst (Die Ausgrabungen von J. Szombathy – Text)*. – Katalogi in monografije 23/1.
- TESSMANN, B. 2001, Schmuck und Trachtzubehör aus Prozor, Kroatien. Ein Beitrag zur Tracht im japodischen Gebiet. – *Acta Praehistorica et Archaeologica* 33, 28–151.
- TIRELLI, M. 2003, Altino (VE): Il santuario per gli *emporoi*. – V / In: L. Malnati, M. Gamba (ur. / eds.), *I Veneti dai bei cavalli*, Canova, 78–79.
- TIRELLI, M. 2005, Il santuario altinate di *Altino-/Altino-*. – V / In: G. Sassatelli, E. Govi (ur. / eds.), *Culti, forma urbana e artigianato a Marzabotto. Nuove prospettive di ricerca*. *Atti del Convegno di Studi Bologna*, S. Giovanni in Monte 3–4 giugno 2003, *Studi e Scavi* n. s. 11, 301–316.
- TIRELLI, M., S. CIPRIANO 2001, Il santuario altinate in località 'Fornace'. – V / In: G. Cresci Marrone, M. Tirelli (ur. / eds.), *Altinum 2, Orizzonti del sacro: culti e santuari antichi in Altino e nel Veneto orientale*, *Studi e ricerche sulla Gallia Cisalpina* 14, 37–60.
- TOMANIČ-JEVREMOV, M. 1988–1989, Žarno grobišče v Ormožu (Das Urnengräberfeld von Ormož). – *Arheološki vestnik* 39/40, 277–322.
- TOMAZO-RAVNIK, T. 1982, Antropološka analiza žganega groba 276 (Anthropologische Analyse des Brandgrabes Nr. 267 – Hof der SAZU). – *Razprave 1. razreda SAZU* 13/2, 212–215.
- TOMAZO-RAVNIK, T. 1984, Antropološko poročilo z grobišča Molnik. – *Arheološki vestnik* 35, 163–165.

- TOMBOLANI, M. 1987, I bronzi etruschi della seconda età del Ferro nel Veneto. – V / In: R. De Marinis (ur. / ed.), *Gli Etruschi a nord del Po*, Mantova, 146–152.
- TOMEDI, G. 1996, Nochmals zur "Fabel von den Traditionsschwertern". Weitere Randbemerkungen zu den Schwertgräbern des Südostalpenraumes und zur "Schwertgrabchronologie". – V / In: T. Stöllner (ur. / ed.), *Europa celtica. Untersuchungen zur Hallstatt- und Latènekultur*, Veröffentlichung des Vorgeschichtlichen Seminars Marburg 12, 167–188.
- TOMEDI, G. 2002, *Das hallstattzeitliche Gräberfeld von Frög. Die Altgrabungen von 1883 bis 1892*. – *Archaeolingua* 14.
- TORELLI, M. 2000, The Hellenization of Etruria. – V / In: M. Torelli (ur. / ed.), *The Etruscans*, Milano, 141–155.
- TORELLI, M. (ur. / ed.) 2000, *The Etruscans*. – Milano.
- TOŠKAN, B., B. ŠTULAR 2008, Pes ali volk? Analiza kanidnega skeleta iz grobišča na Pristavi (Dog or wolf? Analysis of a canid skeleton from the burial site at Pristava). – V / In: A. Pleterski, *Zgodnjerednjevska naselbina na blejski Pristavi. Najdbe (Frühmittelalterliche Siedlung Pristava in Bled. Funde)*, Opera Instituti Archaeologici Sloveniae 14, 153–157 (269–271).
- TOVOLI, S. (ur. / ed.) 1979, *La necropoli villanoviana di Ca' dell'Orbo a Villanova di Castenaso. Problemi del popolamento dal IX al VI secolo a.C.* – Catalogo della mostra, Museo Civico Archeologico, Bologna.
- TREFNÝ, M. 2002, Bronzefunde aus der Býčí skála-Höhle und ihre Beziehungen zum Südostalpenraum und Italien (Bronzové nálezy z Býčí skály a jejich vztahy k jihovýchodoalpínské oblasti a Itálii). – V / In: A. Lang, V. Salač (ur. / eds.), *Fernkontakte in der Eisenzeit (Dálkové kontakty v době železné)*, Konferenz, Liblice 2000, Praha, 360–378.
- TRUHELKA, Č. 1904, *Der vorgeschichtliche Pfahlbau im Savebettebei Donja Dolina (Bezirk Bosnisch-Gradiška)*. Bericht über die Ausgrabungen bis 1904. – Wissenschaftliche Mitteilungen aus Bosnien und der Herzegovina 9.
- TURK, P. 1996, Datacija poznobronastodobnih depojev (The Dating of Late Bronze Age Hoards). – V / In: B. Teržan (ur. / ed.), *Depoje in posamezne kovinske najdbe bakrene in bronaste dobe na Slovenskem 2 (Hoards and Individual Metal Finds from the Eneolithic and Bronze Ages in Slovenia 2)*. – Katalogi in monografije 30, 89–124.
- TURK, P. 2005, *Podobe življenja in mita*. Katalog arheološke razstave. – Ljubljana.
- TURK, P., I. MURGELJ 2008, Ponovno najdeni apulski kraterji iz Stične (Die wiederaufgefundenen apulischen Kratere aus Stična). – V / In: S. Gabrovec, B. Teržan, *Stična II/2. Gomile starejše železne dobe. Razprave (Grabhügel aus der älteren Eisenzeit. Studien)*. – Katalogi in monografije 38 (2010), 159–172.
- TURK, P., J. ISTENIČ, T. KNIFIC, T. NABERGOJ (ur. / eds.) 2009, *Ljubljana: kulturna dediščina reke*. – Ljubljana.
- UMETNOST alpskih Ilirov in Venetov. *Situle od Pada do Donave* 1962, razstavni katalog, Narodni muzej v Ljubljani. – Ljubljana.
- URLEB, M. 1974, *Križna gora pri Ložu: halštatska nekropola (Hallstattzeitliches Gräberfeld Križna gora)*. – Katalogi in monografije 11.
- VELUŠČEK, A. 2007, Figuralna vaza s kolišča pri Igu, Ljubljansko barje, Slovenija (The figural vase from the pile-dwelling near Ig, Ljubljansko barje, Slovenia). – V / In: *Scripta Praehistorica in Honorem Biba Teržan*, Situla 44, 151–168.
- VINSKI-GASPARINI, K. 1973, *Kultura polja sa žarama u sjevernoj Hrvatskoj (Die Urnenfelderkultur in Nordkroatien)*. – Monografije 1.
- VITRI, S. 2001, Lo stato della ricerca protostorica in Carnia. – V / In: S. Vitri, F. Oriolo (ur. / eds.), *I Celti in Carnia e nell'arco alpino centro orientale*. Atti della Giornata di studio, Tolmezzo 30 aprile 1999, Trieste, 19–50.
- VITRI, S., S. CORAZZA, G. SIMEONI 2007, Un pendaglio con simbolo solare da Misincinis di Paularo. – V / In: *Scripta Praehistorica in Honorem Biba Teržan*, Situla 44, 695–706.
- VOJAKOVIČ, P. 2008, Starejšezelzodobna gomila z Vrtičnjaka nad Tupaličami pri Preddvoru na Gorenjskem (The Early Iron Age tumulus from Vrtičnjak above Tupaliče near Preddvor, Slovenia). – *Arheološki vestnik* 59, 149–188.
- VUGA, D. 1982, *Želzodobne Vače*. – Kulturni in naravni spomeniki Slovenije 100.
- VUGA, D. 1988, *Magdalenska gora pri Šmarjem-Sapu v železni dobi*. – Kulturni in naravni spomeniki Slovenije 157.
- VUGA, D. 2006, Recenzija: Sneža Tecco Hvala, Janez Dular, Eva Kocuvan: *Želzodobne gomile na Magdalenski gori*. Eisenzeitliche Grabhügel auf der Magdalenska gora. Ljubljana, Narodni muzej Slovenije, 2004. – *Acta Histriae* 4, 223–248.
- WEISS, R.-M. 1996, Ein reiches Kriegergrab aus Magdalenska gora. Neue Erkenntnisse zu einem alten Fund. – *Acta Praehistorica et Archaeologica* 28, 40–58.
- WEISS, R.-M. 1999, Des Kaisers alte Funde. – V / In: W. Menghin (ur. / ed.), *Hallstattzeit. Die Altertümer im Museum für Vor- und Frühgeschichte* 2, 48–73.
- WELLS, S. P. 1980, *Culture contact and culture change. Early Iron Age central Europe and the Mediterranean world*. – Cambridge.
- WELLS, S. P. 1981, *The Emergence of an Iron Age Economy. The Mecklenburg Grave Groups from Hallstatt and Stična*. – American School of Prehistoric Research, Bulletin 33.
- WELLS, S. P. 1985, Mediterranean trade and culture change in Early Iron Age Central Europe. – V / In: T. C. Champion, J. V. S. Megaw (ur. / eds.), *Settlement and society. Aspects of west European prehistory in the first millennium*, New York, 69–85.
- WERNER, W. M. 1988, *Eisenzeitliche Tensen an der unteren und mittleren Donau*. – Prähistorische Bronzefunde 16/4.
- WESSE, A. 1990, *Die Ärmchenbeile der Alten Welt. Ein Beitrag zum Beginn der Eisenzeit im östlichen Mitteleuropa*. – Universitätsforschungen zur prähistorischen Archäologie 3.
- WILLROTH, K.-H. 1997, Prunkbeil oder Stosswaffe. – V / In: C. Becker et al. (ur. / eds.), *Hrónos*, Internationale Archäologie, Studia honoraria 1, 469–496.
- ZELLER, K. W. 1980, Die modernen Grabungen auf dem Dürrnberg – Techniken und Ergebnisse. – V / In: L. Pauli (ur. / ed.), *Die Kelten in Mitteleuropa: Kultur, Kunst, Wirtschaft*. Salzburger Landesausstellung, 1.

- Mai–30. Sept. 1980 im Keltenmuseum Hallein Österreich, Salzburg, 159–182.
- ZEMMER-PLANK, L., W. SÖLDER (ur. / eds.) 2002, *Kult der Vorzeit in den Alpen. Opfergaben, Opferplätze, Opferbrauchtum (Culti nella preistoria delle Alpi. Le offerte, i santuari, i riti)*. – Bozen / Bolzano.
- ZÜRN, H. 1970, *Hallstattforschungen in Nordwürttemberg. Die Grabhügel von Asperg (Kr. Ludwigsburg), Hirsch-*

- landen (Kr. Leonberg) und Mühlacker (Kr. Vaihingen)*. – Veröffentlichungen des Staatlichen Amtes für Denkmalpflege Stuttgart, Reihe A, Vor- und Frühgeschichte 16.
- ŽERAVICA, Z. 1993, *Äxte und Beile aus Dalmatien und anderen Teilen Kroatiens, Montenegro, Bosnien und Herzegowina*. – Prähistorische Bronzefunde IX/18.

8 INDEKS GROBOV

8 INDEX OF GRAVES

Indeks vsebuje osnovne podatke o grobovih, ki so povzeti po zapisih izkopavalcev. Vsebuje tudi navedbo, kje se najdbe hranijo, in sklic na integralno objavo ter komentar k skladnosti grobnih celot s primarnimi viri. V primeru Mecklenburške zbirke skladnost grobnih celot z Goldbergovimi opisi še ne pomeni, da so objavljeni predmeti dejansko tisti, ki so bili najdeni v navedenem grobu. V rubrikah uporabljene kratice so pojasnjene na začetku knjige; smeri pokopov pa so podane samo v angleški obliki.

The index gives the basic information on graves as provided by the excavators' notes. It also includes references as to where the finds are kept and where in the integral publications they can be found. Furthermore, the index offers comments on the consistency of grave group with the primary sources. In the case of the Mecklenburg Collection, the consistency of grave groups with Goldberg's description does not yet signify that the published objects are exactly those found in the graves cited. Marks and abbreviations used in the columns are explained at the beginning of the book.

<i>Gom./gr.</i> <i>Tum./Gr.</i>	<i>Pokop</i> <i>Rite</i>	<i>Globina</i> <i>Depth (m)</i>	<i>Orientacija</i> <i>Orientation</i>	<i>Spol/star.</i> <i>Sex/Age</i>	<i>Muzej</i> <i>Museum</i>	<i>Stran, tabla</i> <i>Page, plate</i>	<i>Grobna celota</i> <i>Grave group</i>
Laščik – Gom. 4: izkopavanja Ferdinanda Schulza leta 1881/82 Tum. 4: excavated by Ferdinand Schulz in 1881/82						objavljeno v / published in Tecco Hvala/Dular/Kocuvan 2004	
4/1	C			M+F?	NMS	19, 120, T. 1	delno identificirana partly identified
Laščik – Gom. 9: izkopavanja Ferdinanda Schulza leta 1882 Tum. 9: excavated by Ferdinand Schulz in 1882						objavljeno v / published in Tecco Hvala/Dular/Kocuvan 2004	
9/a	S	0,30	E–W	M	NMS	20, 120	ni identificirana unidentified
9/b	C	0,80			“	20, 120	ni identificirana unidentified
9/c	C				“	20, 120	ni identificirana unidentified
1882/1	S			F	NHMW	21, 121, T. 3A	zanesljiva reliable
Laščik – Gom. 1–3, 8–12: izkopavanja Jerneja Pečnika v letih 1892/93 Tum. 1–3, 8–12: excavated by Jernej Pečnik in 1892/93						objavljeno v / published in Tecco Hvala/Dular/Kocuvan 2004	
8/1	C				NMS	20, 120	ni identificirana unidentified
8/2	C			M?	“	20, 120, T. 2B	delno identificirana partly identified
8/3	C				“	20, 120	brez pridakov no grave goods
8/4	C				NHMW	20, 120, T. 2C	zanesljiva reliable
1892/1					NMS	22, 121	ni podatkov no data

<i>Gom./gr. Tum./Gr.</i>	<i>Pokop Rite</i>	<i>Globina Depth (m)</i>	<i>Orientacija Orientation</i>	<i>Spol/star. Sex/Age</i>	<i>Muzej Museum</i>	<i>Stran, tabla Page, plate</i>	<i>Grobna celota Grave group</i>
1892/2	C			F?	NMS	22, 121	ni identificirana unidentified
1892/3				F?	“	22, 121	ni identificirana unidentified
1892/4					“	22, 121	ni podatkov no data
1892/5	C			F?	“	22, 121	ni identificirana unidentified
1892/6	C				“	22, 121, T. 3B	delno identificirana partly identified
1892/7					“	22, 121	ni podatkov no data
1892/8	S			F	“	22, 121	ni identificirana unidentified
1892/9					“	22, 121	ni podatkov no data
1892/10					“	22, 121, T. 3C	delno identificirana partly identified
1892/11	S			F	“	22, 122, T. 4	delno identificirana partly identified
1892/12					“	23, 122	ni podatkov no data
1892/13	C			F	“	23, 122, T. 5A	zanesljiva reliable
1892/14+15	C			F?	“	23, 122	delno identificirana partly identified
1893/1	S			I	NHMW	23, 122, T. 5B	delno ohranjena partly preserved
1893/2	C			F	“	23, 122, T. 6A	delno ohranjena partly preserved
11/1	C				NMS	24, 123	ni identificirana unidentified
12/1	C			M	“	24, 123, T. 6B	delno identificirana partly identified
Preloge – Gom. 2: izkopavanja Jerneja Pečnika v letih 1892–1894 Tum. 2: excavated by Jernej Pečnik in 1892–1894						objavljeno v / published in Tecco Hvala/Dular/Kocuvan 2004	
2/a	S	4	E–W	F	NMS	28, 125, T. 7, 8	delno identificirana partly identified
2/b	S	1,5	E–W	M	“	29, 125, T. 9	delno identificirana partly identified
2/c	S	3	S–N	I	“	30, 125, T. 10A	delno identificirana partly identified
2/d	S	0,5		M	“	30, 125	ni identificirana unidentified
2/e+f				F	“	30, 125, T. 10B	delno identificirana partly identified
2/g	S	3	W–E	M	“	30, 126, T. 11	delno identificirana partly identified
2/h	S	4,5	S–N	F	“	30, 126, T. 12A	delno identificirana partly identified
2/i		0,5			“	31, 126	ni identificirana unidentified
2/j	S+konj? S+horse?	0,5	E–W	M	“	31, 126, T. 13, 14A	delno identificirana partly identified
2/k	S	2		M	“	32, 126, T. 12B	delno identificirana partly identified
2/l	S	2		M	“	32, 126	ni identificirana unidentified

<i>Gom./gr. Tum./Gr.</i>	<i>Pokop Rite</i>	<i>Globina Depth (m)</i>	<i>Orientacija Orientation</i>	<i>Spol/star. Sex/Age</i>	<i>Muzej Museum</i>	<i>Stran, tabla Page, plate</i>	<i>Grobna celota Grave group</i>
2/m	S	4		F	NMS	32, 126	ni identificirana unidentified
2/n	S	5		F	“	32, 127	ni identificirana unidentified
2/o	S	4		I	“	32, 127, T. 14B	delno identificirana partly identified
2/p	S	1,5	E-W	F	“	32, 127, T. 14C	delno identificirana partly identified
2/1-2				M?+F?	NHMW	32, 127, T. 15, 16	ni podatkov no data
2/3				M	“	33, 127, T. 17A	delno skladna partly consistent
2/4					“	33, 127, T. 18A	zanesljiva reliable
2/5				M	“	33, 127, T. 19A	delno skladna partly consistent
2/6				M	“	33, 128, T. 18B	zanesljiva reliable
2/7				M	“	33, 128, T. 17C	zanesljiva reliable
2/8				M?	“	34, 128, T. 17B	zanesljiva reliable
2/9		0,04		F	“	34, 128, T. 19B	delno ohranjena partly preserved
2/10				F	“	34, 128, T. 20A	delno skladna partly consistent
2/11	S	1		I	“	34, 128, T. 20B	delno ohranjena partly preserved
2/12				M	“	34, 128, T. 21, 22	delno skladna partly consistent
2/13	S+konj S+horse	6	W-E	M	“	35, 129, T. 23-27	zanesljiva reliable
2/14	S			F	“	36, 129, T. 20C	delno ohranjena partly preserved
2/15	S			F	“	36, 129, T. 28A	delno skladna partly consistent
2/16	S			F	“	36, 130, T. 20D	zanesljiva reliable
2/17				F	“	36, 130, T. 20E	delno ohranjena partly preserved
2/18				M	“	37, 130, T. 29A	zanesljiva reliable
2/19				F	“	37, 130, T. 28B	zanesljiva reliable
2/20				F	“	37, 130, T. 28C	zanesljiva reliable
2/21	S			I	“	37, 130, T. 29B	zanesljiva reliable
2/22				F	“	37, 130, T. 29C	zanesljiva reliable
2/23					“	37, 130	ni ohranjena unpreserved
2/24				F	“	37, 130, T. 30A	zanesljiva reliable
2/25				F?	“	37, 131, T. 30B	zanesljiva reliable
2/26				M	“	38, 131, T. 31A	delno skladna partly consistent

<i>Gom./gr. Tum./Gr.</i>	<i>Pokop Rite</i>	<i>Globina Depth (m)</i>	<i>Orientacija Orientation</i>	<i>Spol/star. Sex/Age</i>	<i>Muzej Museum</i>	<i>Stran, tabla Page, plate</i>	<i>Grobna celota Grave group</i>
2/27				F	NHMW	38, 131, T. 30D	delno skladna partly consistent
2/28				F	“	38, 131, T. 30C	delno skladna partly consistent
2/29				F	“	38, 131, T. 31B	delno skladna partly consistent
2/30				F	“	38, 131, T. 31C	zanesljiva reliable
2/31	S				“	38, 131, T. 32A	zanesljiva reliable
2/32					“	38, 131, T. 32B	zanesljiva reliable
2/33	S				“	39, 132, T. 32C	zanesljiva reliable
2/34	S				“	39, 132, T. 33A	delno skladna partly consistent
2/35	S				“	39, 132, T. 32D	delno skladna partly consistent
2/36	S				“	39, 132, T. 33B	zanesljiva reliable
2/37	S	3		I	“	39, 132, T. 33C	delno skladna partly consistent
2/38	S	3		M	“	39, 132, T. 34–36	delno skladna partly consistent
2/39				F	“	40, 132, T. 37A	zanesljiva reliable
2/40				F	“	40, 133, T. 37B	delno skladna partly consistent
2/41				M	“	40, 133, T. 38A	delno skladna partly consistent
2/42				M	“	41, 133, T. 39A	delno skladna partly consistent
2/43					“	41, 133, T. 39B	zanesljiva reliable
2/44					“	41, 133, T. 33D	zanesljiva reliable
2/45				M	“	41, 133, T. 40A	zanesljiva reliable
2/46	S	3	SW-NE?	M	“	41, 134, T. 41–44A	zanesljiva reliable
2/47	S	2	N-S	M	“	42, 134, T. 44B, 46A	delno skladna partly consistent
2/48	S	1,5	W-E	I	“	42, 134, T. 46B, 47A	delno skladna partly consistent
2/49		0,25		M	“	43, 135, T. 38B	zanesljiva reliable
2/50	S	1		M	“	43, 135, T. 47B	zanesljiva reliable
2/51	S	2		M	“	43, 135, T. 48A	zanesljiva reliable
2/52	S	2,5		F	“	43, 135, T. 40B	zanesljiva reliable
2/53	S	2		F	“	43, 135, T. 48C	delno skladna partly consistent
2/54	S	2		F	“	44, 135, T. 48B	delno skladna partly consistent
2/55	S	3		I	“	44, 135, T. 49A	zanesljiva reliable

<i>Gom./gr. Tum./Gr.</i>	<i>Pokop Rite</i>	<i>Globina Depth (m)</i>	<i>Orientacija Orientation</i>	<i>Spol/star. Sex/Age</i>	<i>Muzej Museum</i>	<i>Stran, tabla Page, plate</i>	<i>Grobna celota Grave group</i>
2/56		4			NHMW	44, 135, T. 49B	zanesljiva reliable
2/57	S+konj S+horse	3,5	E-W	M	“	44, 135, T. 50-52	zanesljiva reliable
2/58	S	3	W-E	M	“	45, 136, T. 53, 54A	delno ohranjena partly preserved
2/59	S	1		M	“	45, 136, T. 55A	zanesljiva reliable
2/60	S	3,5		M	“	45, 136, T. 56	zanesljiva reliable
2/61		2		F	“	45, 137, T. 54B	delno skladna partly consistent
2/62	S	2,5		M	“	46, 137, T. 57A	delno skladna partly consistent
2/63	S	3		F	“	46, 137, T. 54C	delno ohranjena partly preserved
2/64	S	2		F	“	46, 137, T. 57B	delno ohranjena partly preserved
2/65		3		I	“	46, 137, T. 58A	delno skladna partly consistent
2/66	S	3,5		I	“	46, 137, T. 55B	delno skladna partly consistent
2/67		3		I?	“	46, 137, T. 59A	zanesljiva reliable
2/68		2		F?	“	47, 137, T. 57C	delno ohranjena partly preserved
2/69		2,5		M	“	47, 138, T. 58B	delno skladna partly consistent
2/70		1,5		F?	“	47, 138, T. 59B	zanesljiva reliable
2/71		0,15		M+F?	“	47, 138, T. 59C	delno skladna partly consistent
2/72		5			“	47, 138, T. 59D	zanesljiva reliable
2/73	S	3	N-S	I?	“	47, 138, T. 60A	zanesljiva reliable
2/74	S	4	N-S	M	“	47, 138, T. 60B	delno skladna partly consistent
2/75	S	1	S-N	F?	“	48, 138, T. 61A	zanesljiva reliable
2/76	S	2	E-W	F?	“	48, 139	ni ohranjena unpreserved
2/77	S	5	N-S	M	“	48, 139, T. 61B	zanesljiva reliable
2/78	S	5	S-N	M	“	48, 139, T. 61C	zanesljiva reliable
2/79	S	2	E-S?	F	“	48, 139, T. 61D	zanesljiva reliable
2/80	S	1	S-E?	F	“	48, 139, T. 62A	delno ohranjena partly preserved
2/81	S	3	E-W	I	“	48, 139, T. 62B	zanesljiva reliable
2/82	S	4	E-W	M	“	48, 139, T. 62D	delno skladna partly consistent
2/83	S	2	N-S	F	“	49, 139, T. 62C	delno ohranjena partly preserved
2/84	S	3	S-N	F	“	49, 139, T. 62E	zanesljiva reliable

<i>Gom./gr. Tum./Gr.</i>	<i>Pokop Rite</i>	<i>Globina Depth (m)</i>	<i>Orientacija Orientation</i>	<i>Spol/star. Sex/Age</i>	<i>Muzej Museum</i>	<i>Stran, tabla Page, plate</i>	<i>Grobna celota Grave group</i>
2/85	S	4	E-W		NHMW	49, 140	ni ohranjena unpreserved
2/86	S	3	W-E		“	49, 140	ni ohranjena unpreserved
2/87	S	3,5	E-W		“	49, 140	ni ohranjena unpreserved
2/88	S	3	S-N		“	49, 140	ni ohranjena unpreserved
Preloge – Gom. 3: izkopavanja Jerneja Pečnika leta 1893 Tum. 3: excavated by Jernej Pečnik in 1893						objavljeno v / published in Tecco Hvala/Dular/Kocuvan 2004	
3/a	C				NMS	50, 140	ni identificirana unidentified
3/b	C				“	50, 140	ni identificirana unidentified
3/c	C				“	50, 140	ni identificirana unidentified
Preloge – Gom. 4 (= IV): 3 grobove izkopal Jernej Pečnik leta 1905 Tum. 4 (= IV): 3 graves unearthed by Jernej Pečnik in 1905						objavljeno v / published in Tecco Hvala/Dular/Kocuvan 2004	
4/1	S	2	W-E		NHMW	50, 141, T. 64, 65A	delno skladna partly consistent
4/2	S	2,5	W-E	F	“	51, 141, T. 65B	delno skladna partly consistent
4/3		3		F?	“	51, 141, T. 65C	delno skladna partly consistent
Preloge – Gom. 5: nekaj grobov izkopal Jernej Pečnik leta 1892 Tum. 5: several graves unearthed by Jernej Pečnik in 1892						objavljeno v / published in Tecco Hvala/Dular/Kocuvan 2004	
5/a	S	0,15		M	NMS	51, 141	ni identificirana unidentified
Preloge – Gom. 8 (= VIII): 2 grobova izkopal Jernej Pečnik leta 1892 Tum. 8 (= VIII): 2 graves unearthed by Jernej Pečnik in 1892						objavljeno v / published in Tecco Hvala/Dular/Kocuvan 2004	
8/a	C				NMS	51, 142	ni identificirana unidentified
8/b	C				“	51, 142	ni identificirana unidentified
Preloge – Gom. 13: izkopavanja Jerneja Pečnika in Franza Brattine v letih 1893/94 Tum. 13: excavated by Jernej Pečnik and Franz Brattina in 1893/94						objavljeno v / published in Tecco Hvala/Dular/Kocuvan 2004	
13/1		0,15		M+F?	NHMW	53, 143, T. 66A	delno skladna partly consistent
13/2	S	1,1	SE-NW	F	“	53, 143, T. 66B	zanesljiva reliable
13/3	S	1,1	E-W	M	“	53, 143, T. 66C	zanesljiva reliable
13/4	S	1,4	ENE-WSW		“	53, 143	brez prdatkov no grave goods
13/5	S		NE-SW	M	“	54, 143, T. 67A	zanesljiva reliable
13/6	S	0,9	S-N		“	54, 143, T. 67B	zanesljiva reliable
13/7	S	1,9	W-E	iuv.	“	54, 144, T. 67C	zanesljiva reliable
13/8	S	0,3	SW-NE		“	54, 144, T. 67D	zanesljiva reliable
13/9	S	0,7	NW-SE		“	55, 144	brez prdatkov no grave goods
13/10	C	1		M	“	55, 144, T. 68, 69A	zanesljiva reliable
13/11	S	2,6	NW-SE	iuv.	“	55, 144, T. 69B	zanesljiva reliable

<i>Gom./gr. Tum./Gr.</i>	<i>Pokop Rite</i>	<i>Globina Depth (m)</i>	<i>Orientacija Orientation</i>	<i>Spol/star. Sex/Age</i>	<i>Muzej Museum</i>	<i>Stran, tabla Page, plate</i>	<i>Grobna celota Grave group</i>
13/12	S	2,3	E-W		NHMW	55, 144, T. 69C	zanesljiva reliable
13/13	S	1	ENE-WSW	I	“	55, 144, T. 69D	zanesljiva reliable
13/14	S	2	SE-NW	F	“	55, 144, T. 69E	delno skladna partly consistent
13/15	S	2,2	N-S	F	“	55, 144, T. 70A	zanesljiva reliable
13/16	S	2	SE-NW		“	56, 144	brez pridakov no grave goods
13/17	S	1,2	SE-NW	F	“	56, 144, T. 70B	zanesljiva reliable
13/18	S	1,5	NW-SE		“	56, 144, T. 70C	zanesljiva reliable
13/19	S	1,4	SW-NE	M	“	56, 145, T. 71A	zanesljiva reliable
13/20	S	1,2	nepravilna irregular	M	“	56, 145, T. 71C	zanesljiva reliable
13/21	S	1,4	SW-NE		“	56, 145	brez pridakov no grave goods
13/22	S	1,3	NW-SE	F	“	56, 145, T. 71B	zanesljiva reliable
13/23	S	1,2	SW-NE	M	“	56, 145, T. 72A	delno ohranjena partly preserved
13/24	C	2,7	NE-SW	F	“	56, 145, T. 72B	zanesljiva reliable
13/25	S	2,2	S-N		“	57, 145, T. 74A	zanesljiva reliable
13/26	S	2,5		M?	“	57, 145, T. 72C	zanesljiva reliable
13/27	S	2,3	NW-SE	F	“	57, 145, T. 73A	zanesljiva reliable
13/28	S	2	NW-SE	M	“	57, 145, T. 73B	zanesljiva reliable
13/29	S	3	SW-NE	M	“	57, 146, T. 74B	delno skladna partly consistent
13/30	S	2	NW-SE		“	57, 146	brez pridakov no grave goods
13/31	S	2,8	NW-SE		“	57, 146	brez pridakov no grave goods
13/32	S	1,7	NW-SE		“	57, 146	brez pridakov no grave goods
13/33	S	2,2	N-S	F	“	58, 146, T. 75A	delno skladna partly consistent
13/34	S	2,4	N-S	F	“	58, 146, T. 75B	delno skladna partly consistent
13/35	S	3,2	S-N		“	58, 146, T. 75C	zanesljiva reliable
13/36	S	1,9	NW-SE	F	“	58, 146, T. 76, 77A	delno skladna partly consistent
13/37	S	1,7	S-N	M	“	58, 147, T. 77B	zanesljiva reliable
13/37a	S	1,5		I	“	59, 147, T. 75D	zanesljiva reliable
13/38	S	3,2	SE-NW		“	59, 147, T. 75E	zanesljiva reliable
13/39	S	1,7			“	59, 147, T. 75F	zanesljiva reliable

<i>Gom./gr. Tum./Gr.</i>	<i>Pokop Rite</i>	<i>Globina Depth (m)</i>	<i>Orientacija Orientation</i>	<i>Spol/star. Sex/Age</i>	<i>Muzej Museum</i>	<i>Stran, tabla Page, plate</i>	<i>Grobna celota Grave group</i>
13/40	S	1	NW-SE	M	NHMW	59, 147, T. 78A	zanesljiva reliable
13/41	S	3	S-N	F	“	59, 147, T. 78B	zanesljiva reliable
13/42	S	3,2	NE-SW	F	“	59, 147, T. 78D	zanesljiva reliable
13/43	S	1	NW-SE	F	“	59, 147, T. 78C	zanesljiva reliable
13/44	S	2	S-N		“	59, 147, T. 79A	delno skladna partly consistent
13/45	S	2,5	S-N		“	60, 148, T. 79B	delno skladna partly consistent
13/46	S	1,5	S-N	I?	“	60, 148, T. 79C	delno skladna partly consistent
13/47	S	3	SE-NW	M?	“	60, 148, T. 79D	delno skladna partly consistent
13/48	C	4,5			“	60, 148, T. 80A	zanesljiva reliable
13/49	S	3	NE-SW	F	“	60, 148, T. 80B	zanesljiva reliable
13/50	S	2,2	W-E	M?	“	60, 148, T. 82A	zanesljiva reliable
13/51	S	3,5	SW-NE		“	60, 148, T. 81A	zanesljiva reliable
13/52	C	3		M	“	61, 148, T. 81B	zanesljiva reliable
13/53	S	2,5	NW-SE	M	“	61, 149, T. 82B	delno skladna partly consistent
13/54	S	1,3	NW-SE	M	“	61, 149, T. 82C	zanesljiva reliable
13/55	S	1,6	NW-SE	M	“	61, 149, T. 83-85	zanesljiva reliable
13/56	S	0,5	NE-SW	M	“	62, 149, T. 86A	zanesljiva reliable
13/57	S	1,6	NW-SE	F	“	62, 149, T. 86B	zanesljiva reliable
13/58	S	3,5	NW-SE		“	62, 149	brez pridatkov no grave goods
13/59	S	2,5	S-N		“	62, 149, T. 86C	zanesljiva reliable
13/60	S	1,2	S-N	M	“	62, 149, T. 87A	zanesljiva reliable
13/61	S	3,5		I	“	62, 150, T. 87B	zanesljiva reliable
13/62	S	3	NE-SW		“	62, 150, T. 88A	zanesljiva reliable
13/63	S	1,5	NE-SW	M	“	62, 150, T. 88B	zanesljiva reliable
13/64	S	1,4	S-N	M	“	63, 150, T. 86D	zanesljiva reliable
13/65	S	1,5	S-N	I	“	63, 150, T. 88C	delno skladna partly consistent
13/66	S	0,5	NW-SE	I	“	63, 150, T. 89A	delno skladna partly consistent
13/67	S	1,2	S-N	M	“	63, 150, T. 89B	zanesljiva reliable
13/68	S	2,5	S-N	I?	“	63, 150, T. 90A	zanesljiva reliable

<i>Gom./gr. Tum./Gr.</i>	<i>Pokop Rite</i>	<i>Globina Depth (m)</i>	<i>Orientacija Orientation</i>	<i>Spol/star. Sex/Age</i>	<i>Muzej Museum</i>	<i>Stran, tabla Page, plate</i>	<i>Grobna celota Grave group</i>
13/69	S	2	NW-SE	M?	NHMW	63, 150, T. 89C	delno ohranjena partly preserved
13/70	S	1,5	NW-SE		“	63, 151, T. 90B	zanesljiva reliable
13/71	S	3,5	S-N		“	64, 151, T. 90C	zanesljiva reliable
13/72	S	3	NW-SE		“	64, 151, T. 90D	zanesljiva reliable
13/73	S	3	NE-SW	F	“	64, 151, T. 90E	zanesljiva reliable
13/74	S	3,5	NW-SE		“	64, 151, T. 90F	zanesljiva reliable
13/75	S	3	NW-SE		“	64, 151, T. 90G	zanesljiva reliable
13/76	S	2	NW-SE		“	64, 151, T. 90H	zanesljiva reliable
13/77	S	3	S-N	F?+I	“	64, 151, T. 91	delno skladna partly consistent
13/78	S	2,5	S-N		“	64, 151, T. 92A	zanesljiva reliable
13/79	S	1	NW-SE	I?	“	65, 152, T. 93A	delno skladna partly consistent
13/80	S	1	NW-SE		“	65, 152	brez pridatkov no grave goods
13/81	S	1,5	NW-SE	M	“	65, 152, T. 93B	zanesljiva reliable
13/82	S	2	S-N	M	“	65, 152, T. 93C	zanesljiva reliable
13/83	S	3,5	S-N		“	65, 152	brez pridatkov no grave goods
13/84	S	0,9	S-N	M	“	65, 152, T. 92B	zanesljiva reliable
13/85	S	1,5	neppravilna irregular	M	“	65, 152, T. 94	delno skladna partly consistent
13/86		0,5		M?	“	66, 152, T. 96A	zanesljiva reliable
13/87	S	1,5	NW-SE	F	“	66, 152, T. 95A	zanesljiva reliable
13/88	S	2	S-N	F	“	66, 153, T. 95B	delno skladna partly consistent
13/89	S	3	S-N		“	66, 153, T. 96B	zanesljiva reliable
13/90	S	2,5	NW-SE	F	“	66, 153, T. 96C	zanesljiva reliable
13/91	S	1	NW-SE	M	“	66, 153, T. 96D	zanesljiva reliable
13/92	S	3,5	NW-SE	F	“	66, 153, T. 96E	delno skladna partly consistent
13/93	S	3,5	W-E	F	“	67, 153, T. 96F	delno skladna partly consistent
13/94	S	3	NW-SE		“	67, 153, T. 97A	delno skladna partly consistent
13/95	C	1		M	“	67, 154, T. 97B, 98A	delno ohranjena partly preserved
13/96	S	2	NW-SE	F	“	67, 154, T. 99A	zanesljiva reliable
13/97	S	1,5	NW-SE	F	“	67, 154, T. 100	delno skladna partly consistent

<i>Gom./gr. Tum./Gr.</i>	<i>Pokop Rite</i>	<i>Globina Depth (m)</i>	<i>Orientacija Orientation</i>	<i>Spol/star. Sex/Age</i>	<i>Muzej Museum</i>	<i>Stran, tabla Page, plate</i>	<i>Grobna celota Grave group</i>
13/98	S	2,5	NW-SE	I?	NHMW	68, 154, T. 98B	zanesljiva reliable
13/99	S	2	E-W		“	68, 154, T. 98C	brez pridakov no grave goods
13/100	S	1,7			“	68, 154	brez pridakov no grave goods
13/101	C	4,5		F	“	68, 155, T. 101	zanesljiva reliable
13/102	S	1,8	E-W	F	“	69, 155, T. 99B	delno skladna partly consistent
13/103	S	1,5	NW-SE		“	69, 155, T. 99C	delno skladna partly consistent
13/104	S	2,5	S-N		“	69, 155, T. 98D	delno ohranjena partly preserved
13/105	C	1,8			“	69, 155, T. 102A	delno skladna partly consistent
13/106	S	3	NW-SE	M	“	69, 155, T. 103A	zanesljiva reliable
13/107	S	3,5	N-S		“	70, 155	brez pridakov no grave goods
13/108	S	3,5	NW-SE		“	70, 155, T. 103B	zanesljiva reliable
13/109	S	3	SW-NE	M	“	70, 155, T. 102C	zanesljiva reliable
13/110	S	3,3	SE-NW	F	“	70, 155, T. 102D	zanesljiva reliable
13/111	S	1,8			“	70, 156	brez pridakov no grave goods
13/112	S	2	NW-SE	F	“	70, 156, T. 102B	zanesljiva reliable
13/113	S	1,5	NW-SE		“	70, 156, T. 102E	zanesljiva reliable
13/114	S (dvojni) S (double)	0,8	NW-SE	A+I	“	70, 156, T. 103C	zanesljiva reliable
13/115	S	2	E-W		“	70, 156, T. 104A	delno skladna partly consistent
13/116	S	2,2	S-N		“	70, 156, T. 104B	delno skladna partly consistent
13/117	S	2,2	NW-SE	F	“	71, 156, T. 105, 106	delno skladna partly consistent
13/118	S	2,2	S-N		“	72, 157, T. 104C	zanesljiva reliable
13/119	S+konj S+horse	2	S-N	M	“	72, 157, T. 107-109	delno skladna partly consistent
13/120	S	3	NE-SW	M	“	72, 157, T. 110A	zanesljiva reliable
13/121	S	2,5	NW-SE		“	72, 157, T. 110B	zanesljiva reliable
13/122					“	72, 158	napaka error
13/123	S	1	S-N		“	72, 158	brez pridakov no grave goods
13/124	S	1,5	E-W	M	“	73, 158, T. 111A	zanesljiva reliable
13/125	S	3	N-S		“	73, 158, T. 111B	zanesljiva reliable
13/126	S	2,5	S-N	M	“	73, 158, T. 111C	zanesljiva reliable

<i>Gom./gr. Tum./Gr.</i>	<i>Pokop Rite</i>	<i>Globina Depth (m)</i>	<i>Orientacija Orientation</i>	<i>Spol/star. Sex/Age</i>	<i>Muzej Museum</i>	<i>Stran, tabla Page, plate</i>	<i>Grobna celota Grave group</i>
13/127	S	1,7	S-N	M?	NHMW	73, 158, T. 112A	zanesljiva reliable
13/128	S	2,1	E-W	F?	“	73, 158, T. 111D	zanesljiva reliable
13/129	S	0,6	N-S		“	73, 158	brez pridakov no grave goods
13/130	S	0,5	S-N		“	73, 158	brez pridakov no grave goods
13/131	S	0,4	E-W	F	“	73, 158, T. 113A	zanesljiva reliable
13/132	S	0,6	E-W	M	“	73, 158, T. 113B	delno skladna partly consistent
13/133	S	3	W-E		“	73, 158	brez pridakov no grave goods
13/134	S	3	E-W	F	“	73, 158, T. 111E	delno skladna partly consistent
13/135	C	2,5			“	74, 159, T. 112B	delno skladna partly consistent
13/136	S	3	W-E		“	74, 159, T. 114A	delno skladna partly consistent
13/137	S	1,3	NW-SE	M	“	74, 159, T. 114B	zanesljiva reliable
13/138	S	1	SW-NE		“	74, 159, T. 112C	zanesljiva reliable
13/139	S	3,5	SW-NE		“	74, 159, T. 114C	zanesljiva reliable
13/140	S	2		I	“	74, 159, T. 112D	zanesljiva reliable
13/141	C	2,5		M?	“	74, 159, T. 115A	delno skladna partly consistent
13/142	S	2,2	N-S		“	75, 159, T. 114D	zanesljiva reliable
13/143	S	2,5	NW-SE	F	“	75, 159, T. 114E	delno ohranjena partly preserved
13/144	S	1	SW-NE	F?+M?	“	75, 160, T. 115B	delno ohranjena partly preserved
13/145	S	0,5	S-N	M	“	75, 160, T. 114F	zanesljiva reliable
13/146	C	2		M?	“	75, 160, T. 116A	delno skladna partly consistent
13/147	C				“	76, 160, T. 116B	zanesljiva reliable
13/148	C	2,5			“	76, 160, T. 116C	zanesljiva reliable
13/149	S	2	N-S	I	“	76, 160	brez pridakov no grave goods
13/150	S	0,6	E-W		“	76, 160, T. 117A	delno ohranjena partly preserved
13/151	S	0,9	NW-SE		“	76, 160	brez pridakov no grave goods
13/152	S	1,7	SW-NE	F	“	76, 160, T. 118, 119	delno skladna partly consistent
13/153	S	1,5	W-E	M	“	77, 161, T. 117B	zanesljiva reliable
13/154	S	0,5	NW-SE		“	77, 161	brez pridakov no grave goods
13/155	S	1,1	NW-SE		“	77, 161	brez pridakov no grave goods

<i>Gom./gr. Tum./Gr.</i>	<i>Pokop Rite</i>	<i>Globina Depth (m)</i>	<i>Orientacija Orientation</i>	<i>Spol/star. Sex/Age</i>	<i>Muzej Museum</i>	<i>Stran, tabla Page, plate</i>	<i>Grobna celota Grave group</i>
13/156		0		M	NHMW	77, 161, T. 117C	zanesljiva reliable
13/157	C	2			“	77, 161, T. 120A	zanesljiva reliable
13/158	C	2,3		F	“	77, 161, T. 121A	zanesljiva reliable
13/159	S	1,1	S–N	F	“	77, 161, T. 122A	delno skladna partly consistent
13/160	S	1,5	SW–NE	F	“	78, 161, T. 120B	zanesljiva reliable
13/161	S	2,5	NW–SE	F	“	78, 162, T. 121B	zanesljiva reliable
13/162	S	0,7	W–E	F	“	78, 162, T. 121C	delno ohranjena partly preserved
13/163	C	2,5		F	“	78, 162, T. 123, 124	delno skladna partly consistent
13/164	S	1,3	S–N		“	79, 162, T. 122B	delno skladna partly consistent
13/165	S	2			“	79, 163	brez pridatkov no grave goods
13/166	S	2			“	79, 163, T. 125A	brez pridatkov no grave goods
13/167	S (trojni) S (triple)	2			“	79, 163	brez pridatkov no grave goods
13/168	S	1	E–W		“	79, 163, T. 125B	delno skladna partly consistent
13/169	S	2,5	SW–NE		“	79, 163, T. 125C	zanesljiva reliable
13/170	S	1	S–N		“	80, 163	ni ohranjena unpreserved
13/171	C	1			“	80, 163, T. 125D	delno skladna partly consistent
13/172	S	1,5	NE–SW		“	80, 163, T. 125F	zanesljiva reliable
13/173	C	1			“	80, 163, T. 125E	zanesljiva reliable
Voselca – Gom. 1: 2 grobova izkopal Jernej Pečnik leta 1893 Tum. 1: 2 graves unearthed by Jernej Pečnik in 1893						objavljeno v / published in Tecco Hvala/Dular/Kocuvan 2004	
1/1	S			M	NHMW	82, 164, T. 127–129	nezanesljiva unreliable
1/2	S			F	“	82, 165, T. 130A	nezanesljiva unreliable
Voselca – Gom. 2: izkopavanja Jerneja Pečnika leta 1893 Tum. 2: excavated by Jernej Pečnik in 1893						objavljeno v / published in Tecco Hvala/Dular/Kocuvan 2004	
2/1	C				NHMW	83, 165, T. 131A	delno ohranjena partly preserved
2/2	C				“	83, 165, T. 131B	zanesljiva reliable
2/3	C				“	83, 166, T. 131C	zanesljiva reliable
2/4	C				“	83, 166, T. 132A	zanesljiva reliable
2/5	C				“	83, 166, T. 132B	zanesljiva reliable
2/6	S			F	“	83, 166, T. 133	zanesljiva reliable
2/7				I?	“	84, 166, T. 132C	zanesljiva reliable

<i>Gom./gr. Tum./Gr.</i>	<i>Pokop Rite</i>	<i>Globina Depth (m)</i>	<i>Orientacija Orientation</i>	<i>Spol/star. Sex/Age</i>	<i>Muzej Museum</i>	<i>Stran, tabla Page, plate</i>	<i>Grobna celota Grave group</i>
2/8	S			F	NHMW	84, 166, T. 134A	delno ohranjena partly preserved
2/9				F	“	84, 167, T. 134B	zanesljiva reliable
2/10	S			F	“	85, 167, T. 134C	delno skladna partly consistent
2/11				F?	“	85, 167, T. 135	delno skladna partly consistent
2/12	S			F	“	85, 167, T. 134D	zanesljiva reliable
2/13				M	“	85, 167, T. 136A	delno skladna partly consistent
2/14	S				“	85, 167, T. 136B	delno skladna partly consistent
2/15	C				“	86, 168, T. 137A	delno skladna partly consistent
2/16				F	“	86, 168, T. 137B	delno skladna partly consistent
2/17				F	“	86, 168, T. 137C	delno ohranjena partly preserved
2/18					“	86, 168, T. 137D	delno ohranjena partly preserved
2/19				F	“	86, 168, T. 138	nezanesljiva unreliable
2/20				F	“	87, 168, T. 139A	zanesljiva reliable
2/21				F	“	87, 169, T. 139B	delno skladna partly consistent
2/22				M	“	87, 169, T. 139C	delno skladna partly consistent
2/23				M	“	87, 169, T. 140A	zanesljiva reliable
2/24				M	“	87, 169, T. 140B	zanesljiva reliable
2/25	C				“	87, 169, T. 141A	zanesljiva reliable
Voselca – Gom. 5: izkopavanja Ferdinanda Schulza leta 1882 Tum. 5: excavated by Ferdinand Schulz in 1882						objavljeno v / published in Tecco Hvala/Dular/Kocuvan 2004	
ni podatkov no data					NMS	88, 170	ni identificirana unidentified
Voselca – Gom. 6: izkopavanja Ferdinanda Schulza v letih 1882/83 Tum. 6: excavated by Ferdinand Schulz in 1882/83						objavljeno v / published in Tecco Hvala/Dular/Kocuvan 2004	
6/1	C			F	NMS	88, 170, T. 143A	delno identificirana partly identified
6/2					“	89, 170	brez pridakov no grave goods
6/3	C				“	89, 170, T. 143B	delno identificirana partly identified
6/4				M	“	89, 170	ni identificirana unidentified
6/5					“	89, 170	ni identificirana unidentified

<i>Gom./gr. Tum./Gr.</i>	<i>Pokop Rite</i>	<i>Globina Depth (m)</i>	<i>Orientacija Orientation</i>	<i>Spol/star. Sex/Age</i>	<i>Muzej Museum</i>	<i>Stran, slika Page, figure</i>	<i>Grobna celota Grave group</i>
Preloge – Gom. I: izkopavanja vojvodinje Mecklenburške v letih 1905 in 1908 Tum. I: excavated by the Duchess of Mecklenburg in 1905 and 1908						objavljeno v / published in Hencken 1978	
I/1				F?	PM	12, Fig. 3	ni podatkov no data
I/2		0,9		M?	“	12, Fig. 4	nezanesljiva unreliable
I/2a				F?	“	12, Fig. 5	ni podatkov no data
I/2b				F	“	12, Fig. 6	ni podatkov no data
I/3	C	2,1		M	“	12, Fig. 7	ni ohranjena unpreserved
I/3a				F?	“	13, Fig. 8	delno skladna partly consistent
Preloge – Gom. II: izkopavanja vojvodinje Mecklenburške leta 1905 Tum. II: excavated by the Duchess of Mecklenburg in 1905						objavljeno v / published in Hencken 1978	
II/1					PM	13, Fig. 10	ni podatkov no data
II/1a					“	13, Fig. 11	ni podatkov no data
II/2	S	1,8		M?	“	13, Fig. 12	nezanesljiva unreliable
II/2a				F	“	13, Fig. 13	ni podatkov no data
II/2b					“	13, Fig. 14	ni podatkov no data
II/3	S	1,2		F?	“	14, Fig. 15	brez pridakov no grave goods
II/4				F	“	14, Fig. 16	ni podatkov no data
II/5				F?	“	14, Fig. 17	ni podatkov no data
II/6				M?	“	14, Fig. 18	nezanesljiva unreliable
II/7	S	0,8		F	“	14, Fig. 19	delno skladna partly consistent
II/8					“	14	ni podatkov no data
II/9				F	“	14, Fig. 20	delno skladna partly consistent
II/10		1,4		F?	“	14, Fig. 21	delno skladna partly consistent
II/11				F?	“	14, Fig. 22	ni podatkov no data
II/12				F?	“	15, Fig. 23	ni podatkov no data
II/13					“	15	ni podatkov no data
II/14		1,1		M	“	15, Fig. 24	delno skladna partly consistent
II/15				I?	“	15, Fig. 25	skladna consistent
II/16		1,2		M	“	15, Fig. 26	skladna consistent
II/17	S	1,75		F	“	15	ni ohranjena unpreserved
II/18		2,1		M	“	15, Fig. 27	delno skladna partly consistent

<i>Gom./gr. Tum./Gr.</i>	<i>Pokop Rite</i>	<i>Globina Depth (m)</i>	<i>Orientacija Orientation</i>	<i>Spol/star. Sex/Age</i>	<i>Muzej Museum</i>	<i>Stran, slika Page, figure</i>	<i>Grobna celota Grave group</i>
II/19					PM	15, Fig. 28	ni podatkov no data
II/19a				M?	“	15, Fig. 29	delno ohranjena partly preserved
II/20		1,6		M?	“	15	ni ohranjena unpreserved
II/21		2,2		F?	“	16, Fig. 21	nezanesljiva unreliable
II/22				I	“	16	ni ohranjena unpreserved
Preloge – Gomm. III: izkopavanja vojvodinje Mecklenburške v letih 1907/08 Tum. III: excavated by the Duchess of Mecklenburg in 1907/08						objavljeno v / published in Hencken 1978	
IIIC/1		1,3		F	“	17	ni ohranjena unpreserved
IIIC/2	C	3,9		I?	“	17	ni ohranjena unpreserved
Preloge – Gom. IV (= 4): izkopavanja vojvodinje Mecklenburške leta 1908 Tum. IV (= 4): excavated by the Duchess of Mecklenburg in 1908						objavljeno v / published in Hencken 1978	
IV/ uničen destroyed gr.	S			M?	PM	18, Fig. 41	glej / see Pečnik Tum. 4
IV/1	C?				PM+NMS	17, Fig. 37	ni podatkov no data
IV/2				F	PM	17, Fig. 38	ni podatkov no data
IV/3	S	1,2		M	PM+NMS	17, Fig. 39, 40	nezanesljiva unreliable
IV/4		1,2			PM	18, Fig. 42	skladna consistent
IV/5					“	18, Fig. 43	ni podatkov no data
IV/6				M	“	18, Fig. 44	skladna consistent
IV/7					“	19, Fig. 45	ni podatkov no data
IV/8					“	19	ni podatkov no data
IV/9				F	“	19, Fig. 46	skladna consistent
IV/10	S				“	19	brez pridatkov no grave goods
IV/11				M	“	19, Fig. 47	delno skladna partly consistent
IV/12	S	0		F	“	19, Fig. 48	nezanesljiva unreliable
IV/13					“	19, Fig. 49	delno skladna partly consistent
IV/14	S	1,7			“	19, Fig. 50	delno skladna partly consistent
IV/15				M	“	19, Fig. 51	delno skladna partly consistent
IV/15a	C	2,9		F?	“	20	ni ohranjena unpreserved
IV/16	S	0,8		M	PM+NMS	20, Fig. 52	delno skladna partly consistent
IV/17				M	PM	20, Fig. 53	skladna consistent
IV/18	S?	1,95		M	“	20, Fig. 54	skladna consistent

<i>Gom./gr. Tum./Gr.</i>	<i>Pokop Rite</i>	<i>Globina Depth (m)</i>	<i>Orientacija Orientation</i>	<i>Spol/star. Sex/Age</i>	<i>Muzej Museum</i>	<i>Stran, slika Page, figure</i>	<i>Grobna celota Grave group</i>
IV/19				F	PM	20, Fig. 55	skladna consistent
IV/20	S	1,1		I	“	20, Fig. 56	delno ohranjena partly preserved
IV/21	S	2,4		M	PM+NMS	20, Fig. 57, 58	delno skladna partly consistent
IV/22	S	1,8		F	PM	21, Fig. 59	nezanesljiva unreliable
IV/23					PM+NMS	21, Fig. 60, 61	nezanesljiva unreliable
IV/24	S?	1,2		F	PM	21, Fig. 62	nezanesljiva unreliable
IV/25	S	0,8		M	“	21, Fig. 63, 64	brez pridakov no grave goods
IV/26					“	22, Fig. 65	delno skladna partly consistent
IV/27	C	2,4		F	“	22, Fig. 66	skladna consistent
IV/28					“	22, Fig. 67	ni podatkov no data
IV/29		0,4			“	22, Fig. 68	ni podatkov no data
IV/30	S+konj? S+horse?			M	PM+NMS	22, Fig. 69	ni podatkov no data
IV/30a	S			F	PM	22, Fig. 70	delno skladna partly consistent
IV/31				F	“	22, Fig. 71	delno skladna partly consistent
IV/32	S?+konj S?+horse			M	“	23, Fig. 72, 73	delno skladna partly consistent
IV/33	S			F	“	23, Fig. 74	delno ohranjena partly preserved
IV/34				F	“	24, Fig. 75	nezanesljiva unreliable
IV/35	S				“	24, Fig. 76	ni podatkov no data
IV/36				M?	“	24, Fig. 77	delno ohranjena partly preserved
IV/37				M?	“	24, Fig. 78	nezanesljiva unreliable
IV/38	S	2,6			“	24, Fig. 79	nezanesljiva unreliable
IV/39				F?	“	24, Fig. 80	ni podatkov no data
IV/40	S?+konj S?+horse			M?	“	25, Fig. 81	nezanesljiva unreliable
IV/41				F	“	25, Fig. 82	delno skladna partly consistent
IV/42				M	“	25, Fig. 83	ni podatkov no data
IV/43	S?+konj S?+horse			M	PM+NMS	25, Fig. 84–86	nezanesljiva unreliable
IV/44					PM	26	ni podatkov no data
IV/45					NMS	26, Fig. 87	ni podatkov no data
IV/46					PM	26	ni podatkov no data

<i>Gom./gr. Tum./Gr.</i>	<i>Pokop Rite</i>	<i>Globina Depth (m)</i>	<i>Orientacija Orientation</i>	<i>Spol/star. Sex/Age</i>	<i>Muzej Museum</i>	<i>Stran, slika Page, figure</i>	<i>Grobna celota Grave group</i>
IV/47				M	PM	26, Fig. 88	skladna consistent
IV/48				F	“	26, Fig. 89	skladna consistent
IV/49				F	“	26, Fig. 90	skladna consistent
IV/50					“	27	ni podatkov no data
IV/51				M?	“	27, Fig. 91	skladna consistent
IV/52				M	“	27, Fig. 92	skladna consistent
IV/53	C				“	27	ni ohranjena unpreserved
IV/54	S	0,4		M	PM+NMS	27, Fig. 93	skladna consistent
IV/55	S			M	PM	27, Fig. 94	skladna consistent
IV/56	S			F	“	27, Fig. 95	ni podatkov no data
IV/57					“	27	ni podatkov no data
IV/58	S			M	“	27, Fig. 96	skladna consistent
IV/59					“	28	ni podatkov no data
IV/60				F	“	28, Fig. 97	skladna consistent
IV/61					“	28	ni podatkov no data
IV/62	S	0,2		F?+M?	“	28, Fig. 98	delno skladna partly consistent
IV/ brez št. no grave No.	S				“	28	brez pridakov no grave goods
Laščik – Gom. V: izkopavanja vojvodinje Mecklenburške leta 1913 Tum. V: excavated by the Duchess of Mecklenburg in 1913						objavljeno v / published in Hencken 1978	
V/1	S	1,1	N-S		PM	28, Fig. 101	ni podatkov no data
V/2	S	3,1	N-S	F	“	28, Fig. 102, 103	skladna consistent
V/3	S	1,9	N-S	F	“	29, Fig. 104	nezanesljiva unreliable
V/4	S	2,5	N-S		“	29, Fig. 105	skladna consistent
V/5	S			M	“	29, Fig. 106	delno skladna partly consistent
V/5a	S		NW-SE	F?	“	30, Fig. 107	delno ohranjena partly preserved
V/6-7-7a	S+konj S+horse	1,6	E-W	M	“	30, Fig. 108-112	delno skladna partly consistent
V/8	S	0,45	E-W	M	“	31, Fig. 113	skladna consistent
V/9	S	0,95	E-W	M?	PM+NMS	31, Fig. 114, 115	delno skladna partly consistent
V/10	S	0,35	E-W	M	PM	32, Fig. 116	skladna consistent
V/11	S	0,95	N-S	M	PM+NMS	32, Fig. 117, 118	delno skladna partly consistent

<i>Gom./gr. Tum./Gr.</i>	<i>Pokop Rite</i>	<i>Globina Depth (m)</i>	<i>Orientacija Orientation</i>	<i>Spol/star. Sex/Age</i>	<i>Muzej Museum</i>	<i>Stran, slika Page, figure</i>	<i>Grobna celota Grave group</i>
V/12	S	0,25	E-W	M	PM+NMS	32, Fig. 119, 120	nezanesljiva unreliable
V/13-14	S	0,9	NE-SW	M+F	PM	32, Fig. 121	skladna consistent
V/15	S	0,25	E-W	M	“	33, Fig. 122	delno ohranjena partly preserved
V/16	S	1,6	E-W		“	33, Fig. 123	skladna consistent
V/17	S	1,6	E-W		“	33	brez pridakov no grave goods
V/18	S	1,2	E-W		“	33, Fig. 124	skladna consistent
V/19-20	S	0,2	N-S	M+M	PM+NMS	33, Fig. 125	delno skladna partly consistent
V/21	S	0,7	N-S	M	PM	34, Fig. 126	skladna consistent
V/22	S	3,6	E-W		“	34	brez pridakov no grave goods
V/23	S	2,4	N-S	M	“	34, Fig. 127	delno skladna partly consistent
V/23a,b,c	S (trojni) S (triple)	0,025		M+?+?	“	34	brez pridakov no grave goods
V/24	S	1,4	NW-SE		“	34	brez pridakov no grave goods
V/25	S	1,1	NW-SE		“	34, Fig. 128	skladna consistent
V/26	S?	2,8		M	“	34, Fig. 129	skladna consistent
V/26a	S	2,8		M	PM+NMS	35, Fig. 130-132	delno skladna partly consistent
V/27	S		NE-SW	M	PM	35, Fig. 133	skladna consistent
V/28	S	1,2	E-W		“	35, Fig. 134	skladna consistent
V/29	S+konji S+horses	2,8	N-S	M+M	PM+NMS	36, Fig. 135-149	delno skladna partly consistent
V/30	S	1,7		M	PM	38, Fig. 150	skladna consistent
V/31	S	1,5	SW-NE	M	“	38, Fig. 151	skladna consistent
V/32	S	4,7	E-W	F	“	38, Fig. 152	skladna consistent
V/33	S	1,3	N-S	M	“	38, Fig. 153	delno skladna partly consistent
V/34	S	3,6	E-W	F	“	38, Fig. 154	skladna consistent
V/35	S	1,8	E-W	M	“	39, Fig. 156	skladna consistent
V/36	S	1,2	E-W	F	“	39, Fig. 157	skladna consistent
V/37	S	3,2		F	“	39, Fig. 158	delno skladna partly consistent
V/38	S?	2,4	E-W	F	“	39, Fig. 159	delno ohranjena partly preserved
V/39		0,15		M	“	39, Fig. 160	delno skladna partly consistent
V/40	S	1,75	N-S		“	40, Fig. 161	skladna consistent

<i>Gom./gr. Tum./Gr.</i>	<i>Pokop Rite</i>	<i>Globina Depth (m)</i>	<i>Orientacija Orientation</i>	<i>Spol/star. Sex/Age</i>	<i>Muzej Museum</i>	<i>Stran, slika Page, figure</i>	<i>Grobna celota Grave group</i>
V/41		0,15		M	PM	40, Fig. 162	skladna consistent
V/42		0,1		M	“	40, Fig. 163, 164	delno skladna partly consistent
V/43	S		W-E		“	40, Fig. 165	skladna consistent
V/44-45	S (dvojni) S (double)	2,1			“	41	brez pridakov no grave goods
V/46	S	1,2	NE-S		“	41, Fig. 166	skladna consistent
V/47		0,6		M	PM+NMS	41, Fig. 167	delno skladna partly consistent
V/A	S				PM	41	brez pridakov no grave goods
V/B	S				“	41	brez pridakov no grave goods
V/C	S				“	41, Fig. 168n	brez pridakov no data
V/D	S?			F	“	41, Fig. 169	brez pridakov no data
Preloge – Gom. VI: izkopavanja vojvodinje Mecklenburške leta 1913 Tum. VI: excavated by the Duchess of Mecklenburg in 1913						objavljeno v / published in Hencken 1978	
VI/1		0,06		F	PM	42, Fig. 172	skladna consistent
VI/2	C	0,2		I?	“	42, Fig. 173, 174	skladna consistent
VI/3	C	0,95		M	“	42, Fig. 175, 176	delno skladna partly consistent
VI/4		0,35		F	“	43, Fig. 178	skladna consistent
VI/5					“	43	ni podatkov no data
VI/6	C	0,8		F?	“	43, Fig. 179, 180	delno skladna partly consistent
VI/7	C	0,8			“	43, Fig. 181	skladna consistent
VI/8	S	0,35		F	“	43, Fig. 182	skladna consistent
VI/9	C	2,1			“	43	slabo ohranjena badly preserved
VI/10	C	1,1			“	44, Fig. 183	slabo ohranjena badly preserved
VI/11	C			F	NMS	44, Fig. 184	ni ohranjena unpreserved
VI/12	S?	2,2		M	PM	44, Fig. 185, 186	delno skladna partly consistent
VI/13	C	1,1			“	44, Fig. 187	nezanesljiva unreliable
VI/14	C				“	44, Fig. 188	skladna consistent
VI/15	C			I	“	44, Fig. 189	delno skladna partly consistent
VI/16	C	0,7		I	“	45, Fig. 190	delno skladna partly consistent
VI/17	S	0,35		M	“	45, Fig. 191	skladna consistent
VI/18	C	0,8		F	“	45, Fig. 192	delno skladna partly consistent

<i>Gom./gr. Tum./Gr.</i>	<i>Pokop Rite</i>	<i>Globina Depth (m)</i>	<i>Orientacija Orientation</i>	<i>Spol/star. Sex/Age</i>	<i>Muzej Museum</i>	<i>Stran, slika Page, figure</i>	<i>Grobna celota Grave group</i>
VI/19	C	0,9			PM	45, Fig. 193	delno skladna partly consistent
VI/20	C	0,9		F	“	45, Fig. 194	delno skladna partly consistent
VI/21	S	1,9	E-W	F	“	46, Fig. 195	skladna consistent
VI/22	C	0,45		M	“	46, Fig. 196	skladna consistent
VI/23	C	0,8			PM+NMS	46, Fig. 197	nezanesljiva unreliable
VI/24	C	0,9		F	PM	46, Fig. 198	delno skladna partly consistent
VI/25	C	1,6			“	46, Fig. 199	delno skladna partly consistent
VI/26	C	0,95			“	46, Fig. 200	skladna consistent
VI/27	C	1,4		F	PM+NMS	47, Fig. 201	delno skladna partly consistent
VI/28	C?	0,65			PM+NMS	47, Fig. 202	delno skladna partly consistent
VI/29	S	1,2		M	PM	47, Fig. 203	skladna consistent
VI/30	S	1,9		F	“	47, Fig. 204	skladna consistent
VI/31	S?	1,4		F	“	48, Fig. 205	skladna consistent
VI/32	C?	0,55		M	“	48, Fig. 206	skladna consistent
VI/33	C?	0,45		M	“	48, Fig. 207	delno skladna partly consistent
VI/33a	S?	1,2		I	“	48, Fig. 208	skladna consistent
VI/34	S	0,8	E-W	F	PM+NMS	48, Fig. 209	delno skladna partly consistent
VI/35	C	0,8			PM	48, Fig. 210	nezanesljiva unreliable
VI/36	C	0,35		M?	PM+NMS	49, Fig. 211	delno ohranjena partly preserved
VI/37	S	0,8	N-S		PM	49	brez pridatkov no grave goods
VI/38	S			M	“	49, Fig. 212	skladna consistent
VI/39	S	0,85		M	“	49, Fig. 213	skladna consistent
VI/40		0,25		F	“	50, Fig. 214	skladna consistent
VI/41	S	0,95	E-W	M	“	50, Fig. 215	skladna consistent
VI/42	S?	0,3		M?	“	50, Fig. 216	skladna consistent
VI/42a	C	0,75			“	50	brez pridatkov no grave goods
VI/42b	S?	0,65			“	50	brez pridatkov no grave goods
VI/42c	S?	0,85			“	50	brez pridatkov no grave goods
VI/43	S	0,25			“	50, Fig. 217	skladna consistent

<i>Gom./gr. Tum./Gr.</i>	<i>Pokop Rite</i>	<i>Globina Depth (m)</i>	<i>Orientacija Orientation</i>	<i>Spol/star. Sex/Age</i>	<i>Muzej Museum</i>	<i>Stran, slika Page, figure</i>	<i>Grobna celota Grave group</i>
Preloge – Gom. VII: izkopavanja vojvodinje Mecklenburške leta 1913 Tum. VII: excavated by the Duchess of Mecklenburg in 1913						objavljeno v / published in Hencken 1978	
VII/1	C	1,4		F	PM	51, Fig. 220	delno skladna partly consistent
VII/2	C	0,8		F	“	51, Fig. 221	skladna consistent
VII/3					“	51	ni podatkov no data
VII/4	S?	2,4	N-S	F	“	51, Fig. 222	skladna consistent
VII/5	S	2,4		M	“	51, Fig. 223	delno skladna partly consistent
VII/6		1,35		F	“	52, Fig. 224	skladna consistent
VII/7	C	1,1		F	“	52, Fig. 225, 226	delno skladna partly consistent
VII/8	S	0,2		M	“	52, Fig. 227	delno skladna partly consistent
VII/9	S	1,1		M	“	52, Fig. 228	delno skladna partly consistent
VII/10	S	0,35		F	“	52, Fig. 229	delno skladna partly consistent
VII/11	S?	0,35		M	“	53, Fig. 230	skladna consistent
VII/12	S	0,2		M	“	53, Fig. 231	skladna consistent
VII/13	S	2,2	E-W	M	“	53, Fig. 232	skladna consistent
VII/14	S	0,2		M	“	53, Fig. 233	skladna consistent
VII/15	S	1,4		M?	“	53, Fig. 234	skladna consistent
VII/16	C	1,1		F	“	53, Fig. 235	delno skladna partly consistent
VII/17	S?	1,35		M	“	54, Fig. 236	skladna consistent
VII/18	S	1,1	N-S	F	“	54, Fig. 237	skladna consistent
VII/19	S	0,7		M	“	54, Fig. 238	skladna consistent
VII/20	C	0,45		F	“	54, Fig. 239	skladna consistent
VII/21	S	0,75	N-S		“	54	brez pridatkov no grave goods
VII/22	S	2,2	N-S		“	54, Fig. 240	skladna consistent
VII/23	S	0,35		M	“	54, Fig. 241	skladna consistent
VII/24	S	2,4	N-S	M?	“	55, Fig. 242, 243	delno skladna partly consistent
VII/25	S	2,4	E-W	F	“	55, Fig. 244, 245	skladna consistent
VII/26	S	0,25		F	“	55, Fig. 246	delno skladna partly consistent
VII/27	S	1,95	E-W	F	“	55, Fig. 247	delno ohranjena partly preserved
VII/28	C	0,4		I?	“	55, Fig. 248	nezanesljiva unreliable

<i>Gom./gr. Tum./Gr.</i>	<i>Pokop Rite</i>	<i>Globina Depth (m)</i>	<i>Orientacija Orientation</i>	<i>Spol/star. Sex/Age</i>	<i>Muzej Museum</i>	<i>Stran, slika Page, figure</i>	<i>Grobna celota Grave group</i>
VII/29	S	1,4	E-W		PM	56, Fig. 249	skladna consistent
VII/30	C	1,95		F	“	56, Fig. 250	nezanesljiva unreliable
VII/31	S?	0,05		F	“	56, Fig. 251	skladna consistent
VII/32	C	0,95			“	56, Fig. 252	skladna consistent
VII/33	S	1,1	S-N		“	57	brez pridatkov no grave goods
VII/34	C	0,35			“	57, Fig. 253	delno skladna partly consistent
VII/35		0,25			“	57, Fig. 254	delno skladna partly consistent
VII/36	S	0,2		M	“	57, Fig. 255	delno skladna partly consistent
VII/37	S	1,95		F	“	57, Fig. 256	skladna consistent
VII/38	S	0,9		F	“	57, Fig. 257	skladna consistent
VII/39	S+konj S+horse	0,9	W-E	M	“	58, Fig. 258–259	delno skladna partly consistent
VII/40	S	1,65	N-S	F+I?	“	58, Fig. 260–262	delno skladna partly consistent
VII/41	S	0,9	E-W	M	“	59, Fig. 263	skladna consistent
VII/42	S	1,4	E-W		“	59, Fig. 264	skladna consistent
VII/43	S	1,4			“	60	brez pridatkov no grave goods
VII/44	S	2,05	E-W	M	“	60, Fig. 265	delno skladna partly consistent
VII/45	C	0,35			“	60, Fig. 266	nezanesljiva unreliable
VII/46	C	0,2		F	“	60, Fig. 267	skladna consistent
VII/47	C	0,35			“	61, Fig. 268	delno skladna partly consistent
VII/48	S	0,95	N-S	F	“	61, Fig. 269	skladna consistent
VII/49	S		N-S	F	“	61, Fig. 270	skladna consistent
VII/50	S	0,95	S-N	M	“	61, Fig. 271, 272	skladna consistent
VII/51	S			M	“	61, Fig. 273	delno skladna partly consistent
VII/52	S			M	“	61	ni ohranjena unpreserved
VII/53	C				“	62	ni podatkov no data

<i>Gom./gr.</i> <i>Tum./Gr.</i>	<i>Pokop</i> <i>Rite</i>	<i>Globina</i> <i>Depth (m)</i>	<i>Orientacija</i> <i>Orientation</i>	<i>Spol/star.</i> <i>Sex/Age</i>	<i>Muzej</i> <i>Museum</i>	<i>Stran, slika</i> <i>Page, figure</i>	<i>Grobna celota</i> <i>Grave group</i>
Preloge – Gom. VIII: izkopavanja vojvodinje Mecklenburške leta 1913 Tum. VIII: excavated by the Duchess of Mecklenburg in 1913						objavljeno v / published in Hencken 1978	
VIII/1	S	1,1			PM	62, Fig. 276	delno skladna partly consistent
VIII/2	S	1,4		M	“	62, Fig. 277	skladna consistent
VIII/3	S	1,2	E–W	F+I	“	62, Fig. 278	skladna consistent
VIII/4	S	1,6		I?	“	63, Fig. 279	skladna consistent
VIII/5	S	1,6		M	“	63, Fig. 280	delno skladna partly consistent
VIII/6	S	1,7	E–W	M	“	63, Fig. 281	skladna consistent
VIII/7	S	1,05			“	63	brez pridatkov no grave goods
VIII/8	S	1,5		M	“	63, Fig. 282	skladna consistent
VIII/9		1,1		F	“	63, Fig. 283	skladna consistent
VIII/10–11	S	0,8	E–W	F+A	“	63, Fig. 284	nezanesljiva unreliable
VIII/12	S	1,45	E–W		“	64	brez pridatkov no grave goods
VIII/13	S?	1,6			“	64, Fig. 285	skladna consistent
VIII/14	C	0,45			“	64, Fig. 286	delno skladna partly consistent
VIII/15	S	1,1	N–S	M	“	64, Fig. 287, 288	skladna consistent
VIII/16	S	0,9	N–S	M	“	64, Fig. 289, 290	delno skladna partly consistent
VIII/17–18	S	2,05	S–N	F+A	“	64, Fig. 291	skladna consistent
VIII/19	S	0,45		M	“	65, Fig. 292	delno skladna partly consistent
VIII/20					“	65, Fig. 293	delno skladna partly consistent
VIII/α					“	65, Fig. 294	ni podatkov no data
VIII/β					“	65, Fig. 295	ni podatkov no data
Preloge – Gom. IX: izkopavanja vojvodinje Mecklenburške leta 1913 Tum. IX: excavated by the Duchess of Mecklenburg in 1913						objavljeno v / published in Hencken 1978	
Ni podatkov No data					PM	65, Fig. 297	ni podatkov no data
Preloge – Gom. X: izkopavanja vojvodinje Mecklenburške leta 1913 Tum. X: excavated by the Duchess of Mecklenburg in 1913						objavljeno v / published in Hencken 1978	
X/1	S	1,45	S–N		PM	66	brez pridatkov no grave goods
X/2	S	2,05	N–S	M	“	66, Fig. 299	delno skladna partly consistent
X/3	S	2,1	N–S		“	66	brez pridatkov no grave goods
X/4	S	1,5	W–E	F	“	66, Fig. 300	skladna consistent
X/5	S	2,05	W–E		“	66	brez pridatkov no grave goods

<i>Gom./gr. Tum./Gr.</i>	<i>Pokop Rite</i>	<i>Globina Depth (m)</i>	<i>Orientacija Orientation</i>	<i>Spol/star. Sex/Age</i>	<i>Muzej Museum</i>	<i>Stran, slika Page, figure</i>	<i>Grobna celota Grave group</i>
X/6	S	1,5	NE-SW		PM	67	brez pridatkov no grave goods
X/7	S	0,95	NE-SW		“	67	brez pridatkov no grave goods
X/8	S	2,3	S-N		“	67	brez pridatkov no grave goods
X/9	S	1,45	S-N		“	67	brez pridatkov no grave goods
X/10	S	1,6	E-W	F	“	67, Fig. 301	delno skladna partly consistent
X/11	S	1,4	E-W		“	67	brez pridatkov no grave goods
X/12	S	0,5	N-S	M	“	67, Fig. 302	skladna consistent
X/13	S	0,3	N-S	F	“	67, Fig. 303	skladna consistent
X/14	S	0,55	N-S	M	“	67, Fig. 304	delno skladna partly consistent
X/15a	S	1,05	SE-NW		“	68	delno skladna partly consistent
X/15b	S	1,05	N-S	M	“	68, Fig. 305	delno skladna partly consistent
X/16	S	1,8	E-W	M	“	68, Fig. 306	skladna consistent
X/17	S	2,1	E-W		“	68	brez pridatkov no grave goods
X/18	S	0,7	S-N	M	“	68, Fig. 307	skladna consistent
X/19	S	0,6	NE-SW		“	68	brez pridatkov no grave goods
X/20	S	0,6	N-S		“	68, Fig. 308	skladna consistent
X/21	S	0,8	N-S	M	“	69, Fig. 309, 310	skladna consistent
X/21a	S	1,55	N-S	M	“	69, Fig. 311, 312	skladna consistent
X/22	S	2,2	NE-SW	F	“	69, Fig. 313	skladna consistent
X/23	S	1,95	NW-SE	M	“	69, Fig. 314	skladna consistent
X/24	S	2,4	N-S	I	“	69, Fig. 315	skladna consistent
X/25	S	0,9	N-S	M	“	70, Fig. 316, 317	skladna consistent
X/26	S	2,9	S-N	F	“	70, Fig. 318	delno skladna partly consistent
X/27	S	1,7	N-S		“	70	brez pridatkov no grave goods
X/28	S	0,55	N-S	M	“	70, Fig. 319	delno skladna partly consistent
X/29	S	0,7	NE-S	M	“	70, Fig. 320	skladna consistent
X/30	S	1,95	E-W		“	71	nezanesljiva unreliable
X/31	S	1,4	E-W		“	71, Fig. 321	delno skladna partly consistent
X/32-33	S		S-N	M+M	PM+NMS	71, Fig. 322-324	nezanesljiva unreliable

<i>Gom./gr. Tum./Gr.</i>	<i>Pokop Rite</i>	<i>Globina Depth (m)</i>	<i>Orientacija Orientation</i>	<i>Spol/star. Sex/Age</i>	<i>Muzej Museum</i>	<i>Stran, slika Page, figure</i>	<i>Grobna celota Grave group</i>
X/34-35	S	0,95	NE-S	F+F	PM	72, Fig. 325, 326	skladna consistent
X/36	S	0,85	E-W		“	72, Fig. 327	skladna consistent
X/37	S	1,3	E-W	F	“	72, Fig. 328	skladna consistent
X/37a					PM+NMS	72, Fig. 329	ni podatkov no data
X/38	S	0,85	E-W	F	PM	72, Fig. 330	delno skladna partly consistent
X/39	S	2,4			“	73, Fig. 331	nezanesljiva unreliable
X/40	S	1,7	E-W		“	73	brez pridatkov no grave goods
X/41	S	1,85	N-S	M?	“	73, Fig. 332	delno skladna partly consistent
X/42	S	0,95	SE-W	F	“	73, Fig. 333	skladna consistent
X/43	C?	0,6		F	“	73, Fig. 334	nezanesljiva unreliable
X/44	S	2,05	W-SE	M?	“	74, Fig. 335	skladna consistent
X/45	S	1,95	SE-W	M	“	74, Fig. 336	skladna consistent
X/46	S	1,6	N-S	M	“	74, Fig. 337	delno skladna partly consistent
X/47	S	0,9	SE-W		“	74	brez pridatkov no grave goods
X/48	S	1,1	SE-NW		“	74, Fig. 338	skladna consistent
X/49	S	1,5	SE-NW		“	74	brez pridatkov no grave goods
X/50	S	1,6	SE-NW		PM+NMS	74, Fig. 339	delno skladna partly consistent
X/51	S	1,9	SW-NE	M	PM	75, Fig. 340, 341	delno skladna partly consistent
X/52	S	1,9	SW-NE	M	“	75, Fig. 342, 343	skladna consistent
X/53	S	1,7	E-W		“	76	brez pridatkov no grave goods
X/54	S	0,7	N-S	M	“	76, Fig. 344	skladna consistent
X/55	S	1,05	E-W	F	PM+NMS	76, Fig. 345	nezanesljiva unreliable
X/56	S	1,9	E-W	F	PM	76, Fig. 346	skladna consistent
X/57	S	1,8	SE-NW		“	76	brez pridatkov no grave goods
X/58	S	1,1	N-S		“	76	brez pridatkov no grave goods
X/59	S	1,1	E-W		“	76	brez pridatkov no grave goods
X/60	S	1,9	E-W	F	“	76, Fig. 347	delno skladna partly consistent
X/61	S	1,4	S-N	F	“	76, Fig. 348	skladna consistent
X/62	S	1,2	N-SE	M	“	77, Fig. 349	delno skladna partly consistent

<i>Gom./gr. Tum./Gr.</i>	<i>Pokop Rite</i>	<i>Globina Depth (m)</i>	<i>Orientacija Orientation</i>	<i>Spol/star. Sex/Age</i>	<i>Muzej Museum</i>	<i>Stran, slika Page, figure</i>	<i>Grobna celota Grave group</i>
X/63	S	1,3	E-N		PM	77	ni ohranjena unpreserved
X/64	S	0,25	E-W	M	PM+NMS	77, Fig. 350	delno skladna partly consistent
X/65	S	1,25	NE-W	M	PM	77, Fig. 351	skladna consistent
X/66	C	0,85			“	77	ni ohranjena unpreserved
X/67	S	1,2	E-W	I	“	78, Fig. 352	nezanesljiva unreliable
X/68	S	1,6	E-W		“	78	brez pridatkov no grave goods
X/69	S	1,1	S-NE	M	“	78, Fig. 353	delno skladna partly consistent
X/70	S	1	E-W	M	“	78, Fig. 354	skladna consistent
X/71	S?	0,05			“	78, Fig. 355	nezanesljiva unreliable
X/72	S	0,5	NE-SW	F	“	79, Fig. 356, 357	skladna consistent
X/73	S	0,45			“	79, Fig. 358	skladna consistent
X/74	S	0,45	NE-SW		“	79	brez pridatkov no grave goods
X/75	S	0,5	E-W	F	PM+NMS	79, Fig. 359	delno skladna partly consistent
X/76	S	0,85	E-W	M	PM	80, Fig. 360	skladna consistent
X/77	S	0,1			“	80, Fig. 361	skladna consistent
X/78	S?	0,05		F	“	80, Fig. 362	skladna consistent

Opera Instituti Archaeologici Sloveniae

1. Janez Dular, Slavko Ciglencečki, Anja Dular, Kučar. Železnodobno naselje in zgodnjekrščanski stavbni kompleks na Kučarju pri Podzemlju / Eisenzeitliche Siedlung und frühchristlicher Gebäudekomplex auf dem Kučar bei Podzemelj, 1995. (EUR 14.60)
2. Ivan Turk (ed.), Moustérienska "koščena piščal" in druge najdbe iz Divjih bab I v Sloveniji / Mousterian "bone flute" and other finds from Divje Babe I cave site in Slovenia, 1996. (EUR 14.60)
3. Jana Horvat (with contributions by Vesna Svetličič, Meta Bole, Metka Culiberg, Draško Josipović, Marko Stokin, Nina Zupančič), Sermin. Prazgodovinska in zgodnjorimska naselbina v severozahodni Istri / A Prehistoric and Early Roman Settlement in Northwestern Istria, 1997. (EUR 14.60)
4. Slavko Ciglencečki (with contributions by Zvezdana Modrijan, Andreja Dolenc Vičič, Ivan Turk), Tinje nad Loko pri Žusmu. Poznoantična in zgodnjerednjevska naselbina / Tinje oberhalb von Loka pri Žusmu. Spätantike und frühmittelalterliche Siedlung, 2000. (EUR 14.60)
5. Janez Dular, Irena Šavel, Sneža Tecco Hvala, Bronastodobno naselje Oloris pri Dolnjem Lakošu / Bronzezeitliche Siedlung Oloris bei Dolnji Lakoš, 2002. (EUR 14.60)
6. Janez Dular, Halštatske nekropole Dolenjske / Die hallstattzeitlichen Nekropolen in Dolenjsko, 2003. (EUR 20.70)
7. Irena Lazar, Rimsko steklo Slovenije / The Roman glass of Slovenia, 2003. (EUR 27.40)
8. Anton Velušček (ed.), Hočevarica. Eneolitsko kolišče na Ljubljanskem barju / An eneolithic pile dwelling in the Ljubljansko barje, 2004. (EUR 52.40)
9. Ivan Turk (ed.), Viktorjev spodmol in / and Mala Triglavca. Prispevki k poznavanju mezolitskega obdobja v Sloveniji / Contributions to understanding the Mesolithic period in Slovenia, 2004. (EUR 42.40)
10. Anton Velušček (ed.), Resnikov prekop. Najstarejša koliščarska naselbina na ljubljanskem barju / The oldest pile-dwelling settlement in the Ljubljansko barje, 2005. (EUR 40.00)
11. Andrej Gaspari (ed.), Zalag pri Verdu. Tabor kamenodobnih lovcev na zahodnem robu Ljubljanskega barja / Zalag near Verd. Stone Age hunters' camp at the western edge of the Ljubljansko barje, 2006. (EUR 43.00)
12. Janez Dular, Sneža Tecco Hvala, South-Eastern Slovenia in the Early Iron Age. Settlement – Economy – Society / Jugovzhodna Slovenija v starejši železni dobi. Poselitev – gospodarstvo – družba, 2007. (EUR 58.00)
13. Ivan Turk (ed.), Divje babe I. Paleolitsko najdišče mlajšega pleistocena v Sloveniji. I. del: Geologija in paleontologija / Divje babe I. Upper Pleistocene Palaeolithic site in Slovenia. Part I: Geology and Palaeontology, 2007. (EUR 82.00)
14. Andrej Pleterski (with Timotej Knific, Borut Toškan, Janez Dirjec, Benjamin Štular and Mateja Belak), Zgodnjerednjevska naselbina na blejski Pristavi. Najdbe / Frühmittelalterliche Siedlung Pristava in Bled. Funde, 2008. (EUR 51.00)
15. Benjamin Štular, Mali grad. Visokosrednjeveški grad v Kamniku / Mali grad. High Medieval Castle in Kamnik, 2008. (EUR 51.00)
16. Anton Velušček (ed.), Koliščarska naselbina Stare gmajne in njen čas. Ljubljansko barje v 2. polovici 4. tisočletja pr. Kr. / Stare gmajne pile-dwelling settlement and its era. The Ljubljansko barje in the 2nd half of the 4th millennium BC, 2009. (EUR 56.00)
17. Jana Horvat, Alma Bavdek, Okra. Vrata med Sredozemljem in Srednjo Evropo / Ocra. The gateway between the Mediterranean and Central Europe, 2009. (EUR 51.00)
18. Janez Dular, Marjana Tomanič Jevremov (with contributions by Bortu Toškan and Janez Dirjec), Ormož. Utrjeno naselje iz pozne bronaste in starejše železne dobe / Ormož. Befestigte Siedlung aus der späten Bronze- und der älteren Eisenzeit, 2010. (EUR 57.00)

19. Andrej Pleterski (with contributions by Igorj Bahor, Vid Pleterski, Marko Žagar and Veronika Pflaum), Zgodnjesrednjeveška naselbina na blejski Pristavi. Tafonomija, predmeti in čas. / Frühmittelalterliche Siedlung Pristava in Bled. Taphonomie, Fundgegenstände und zeitliche Einordnung, 2010. (EUR 39.00)
20. Jana Horvat and Andreja Dolenc Vičič (with the contribution of Marjana Tomanič Jevremov and Marija Lubšina Tušek), Arheološka najdišča Ptuja. Rabelčja vas / Archaeological Sites of Ptuj. Rabelčja vas, 2010. (EUR 45.00)
21. Borut Toškan (ed.), Drobci ledenodobnega okolja. Zbornik ob življenjskem jubileju Ivana Turka / Fragments of Ice Age environments. Proceedings in Honour of Ivan Turk's Jubilee, 2011. (EUR 45.00)
22. Anton Velušček (ed.), Spaha, 2011. (EUR 47.00)
23. Slavko Ciglenečki, Zvezdana Modrijan, Tina Milavec (with contributions of Benjamin Štular, Saša Čaval and Ivan Šprajc), Poznoantična utrjena naselbina Tonovcov grad pri Kobaridu. Naselbinski ostanki in interpretacija / Late Antique fortified settlement Tonovcov grad near Kobarid. Settlement remains and interpretation, 2011. (EUR 55.00)
24. Zvezdana Modrijan, Tina Milavec (with contributions of Peter Kos, Dragan Božič, Matija Turk, Petra Leben Seljak, Borut Toškan, Janez Dirjec, Francesco Boschini and K. Patrick Fazioli), Poznoantična utrjena naselbina Tonovcov grad pri Kobaridu. Najdbe / Late Antique fortified settlement Tonovcov grad near Kobarid. Finds, 2011. (EUR 55.00)
25. Maja Andrič (ed.), Dolgoročne spremembe okolja 1, 2012. (EUR 30.00)

Janez Dular

Halštatske nekropole Dolenjske
Die hallstattzeitlichen Nekropolen in Dolenjsko
 (Hallstatt Necropolises in the Dolenjska Region)

This publication presents fifty-four Hallstatt necropolises from central Slovenia, which are crucial to the course of researching the settlement and social structures of the Early Iron Age. Topographic sources are proffered as well as all the excavated materials, among which are also unique specimens.

The book is divided into three parts. The first section extends a review of the history of excavations of Hallstatt tumuli, from the very onset and all through to WWI. It is a comprehensive study of the history of archaeology in Slovenia, posing the development of museology, the heritage protection profession and the professional and scientific efforts of the then investigators. Numerous illustrations of yet unpublished documents, preserved mainly in foreign museums and archives, are incorporated in the text.

The second section is dedicated to the issue of chronology and the cultural-historical evaluation of Hallstatt necropolises in the Dolenjska region, which regarding their richness easily compare with the most important of necropolises in neighboring countries. It is precisely the tumulus necropolises from the Dolenjska region that form the foundations for the concept of the southeastern Alpine Hallstatt culture, which during the first millennium BC represented one of the most developed cultures in Europe.

The third part of the book presents the necropolises equipped with a detailed description of each site, a concise history of investigations and a catalogue of the excavated materials, all published in the plates.

2003, (Opera Instituti Archaeologici Sloveniae, 6), 272 pages, 149 b-w photographs, 92 plates, 21 x 29,5 cm, hardcover, ISBN 961-6358-18-9.

Price: EUR 20.70

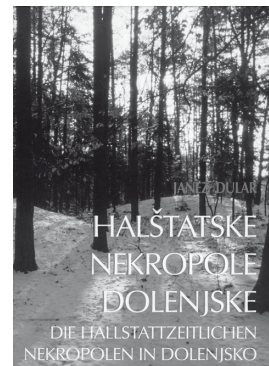

Janez Dular, Sneža Tecco Hvala

South-Eastern Slovenia in the Early Iron Age.

Settlement – Economy – Society

Jugovzhodna Slovenija v starejši železni dobi.

Poselitev – gospodarstvo – družba

The topic of this monograph is southeastern Slovenia in the 1st millennium BC. The first part of the book deals with the history of research, data acquisition, with a critical discussion of archaeological sources, a geographic outline of the region, and an explanation of the chronological system used in the research.

The core of the treatise deals with the settlement structures and patterns in the Late Bronze Age and the Iron Age, as well as the dynamics of the colonization and integration processes, the relationship between lowland and upland settlements, and the issue of extra muros settlement in the vicinity of major centres.

The hierarchy of the settlements is also one focus of this publication. All the centres are fully described with maps, plans and images. Particular attention is paid to the density of the settlement network in relation to natural resources and communications, and in fact, to those factors that have a substantial impact on economic subsistence and social power. The last chapter is dedicated to the social organization and historical turning points that significantly marked the long-term development of this region.

The catalogue of sites at the end of the book contains 510 records with added ground-plans and bibliographic references.

2007, (Opera Instituti Archaeologici Sloveniae, 12), 392 pp., 4 colour drawings and maps, 275 b-w drawings, photos, tables, graphs and maps, 21 x 29,5 cm, hardcover, ISBN 978-961-254-000-5.

Price: EUR 58.00

Slavko Ciglenečki, Zvezdana Modrijan, Tina Milavec

(with contributions of Benjamin Štular, Saša Čaval, Ivan Šprajc)

Poznoantična utrjena naselbina Tonovcov grad pri Kobaridu

Naselbinski ostanki in interpretacija

Late Antique fortified settlement Tonovcov grad near Kobarid

Settlement remains and interpretation

This book presents the results of field investigations at Late Antique hilltop settlement Tonovcov grad near Kobarid, belonging to the best preserved Late Antique settlements in Slovenia and border eastern Alpine area. The position of the settlement and its present-day appearance were presented, as well as the archaeological picture of the Soča River valley and the road network in Late Antiquity.

Investigations, going on from 1993 to 2005, reveals the remains of three early Christian churches, some dwelling houses and a water cistern. The book presents the stratigraphic situation and the settlement phases in all excavation fields as well as their dating. The first prosperity of the Late Antique settlement started in the middle of the 4th cent. and lasted to the first decades of the 5th cent. Due to the strong building activities at the beginning of the 6th cent., the buildings of the first phase were poorly preserved, however rich small finds were found. The life in the settlement reaches its peak in the beginning of the 6th cent. New dwelling houses and an ecclesiastical complex of three connected churches were built. The quality of the preservation of the churches enabled a boarder study of early Christian architecture in the eastern Alpine and Adriatic area.

Settlement is placed in the boarder framework of the western Slovenia and Friuli in the Late Antiquity. In the second half of the 4th cent. it represented an important part of the Late Roman defence system of Italy and in the 6th century a religious and administrative centre of the autochthonous inhabitants in the Soča River valley. The last zenith of the settlement dated in the middle of the 6th cent., when it played an important role in consolidation of the byzantine authority after the byzantine-gothic war. The decline of the settlement dated in the beginning of the 7th cent.

2011, (Opera Instituti Archaeologici Sloveniae, 23), 304 pages, 211 b-w and colour photos, drawings and charts, 5 appendices, 20 x 29 cm, hardcover, ISBN 978-961-254-331-0.

Price: EUR 55.00

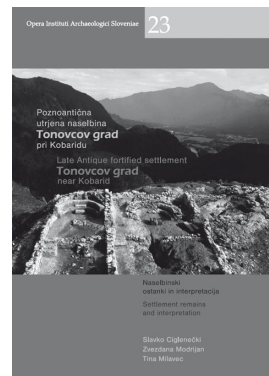
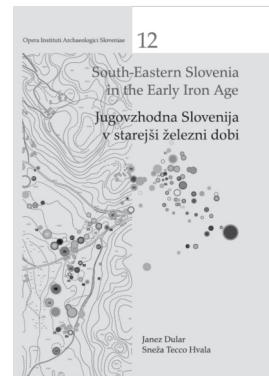

Zvezdana Modrijan, Tina Milavec
(with contributions of Peter Kos, Dragan Božič, Matija Turk, Petra Leben Seljak,
Borut Toškan, Janez Dirjec, Francesco Boschin and K. Patrick Fazioli)

Poznoantična utrjena naselbina Tonovcov grad pri Kobaridu
Najdbe
Late Antique fortified settlement Tonovcov grad near Kobarid
Finds

All finds from the field investigations at Tonovcov grad near Kobarid are published in the second volume. An exceptional number of finds represents the base for studies of the material culture in Late Antiquity (metallic finds, glass finds, pottery and coin finds), as well as for the others archaeological (anthropological and zoological) remains.

2011, (Opera Instituti Archaeologici Sloveniae, 24), 560 pages, 93 b-w and 14 colour photos, drawings and charts, 80 tables and graphs, 106 plates, 20 x 29 cm, hardcover, ISBN 978-961-254-331-0.

Price: EUR 55.00



Maja Andrič (ed.)

Dolgoročne spremembe okolja 1

Changes of past and present environment of Slovenia are discussed in nine papers in this book [Long-term environmental changes 1]. They were written by 21 authors, coming from 14 research organisations. Our aim is to increase multidisciplinary communication and cooperation between Slovenian researchers, working in the fields of palaeoecology and ecology. Research topics include: archaeozoology, biology, ecology, geoarchaeology, palynology, nature protection, dendrochronology, archaeobotany, geochemistry, Karst research and geography.

2012, (Opera Instituti Archaeologici Sloveniae, 25), 120 pages, 10 colour and 4 b-w photos, 14 graphs, 12 tables and 13 maps, 20 x 29 cm, hardcover, ISBN 978-961-254-376-1.

Price: EUR 30.00

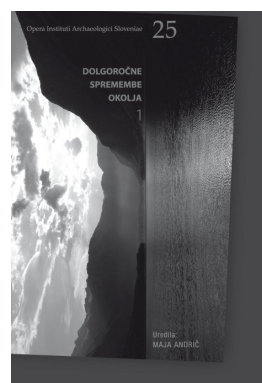

Katalogi in monografije / Catalogi et Monographiae 36

Sneža Tecco Hvala, Janez Dular, Eva Kocuvan

**Železnodobne gomile na Magdalenski gori
Eisenzeitliche Grabhügel auf der Magdalenska gora**

The publication presents the material from Iron Age cemeteries of Magdalenska gora excavated in the late 19th century. It comprises the objects of 332 graves and 510 finds without context from 18 barrows, preserved in the collections of the National Museum of Slovenia and Naturhistorisches Museum in Vienna. It also contains the topographic situation of the hillfort settlement and the barrows, the history of the excavations, the catalogue of the grave equipment and the chronological and culturalhistorical sketch of this archaeological site.

Magdalenska gora near Ljubljana represents the trade and production Hallstatt centre in central Slovenia, particularly in the 5th and 4th centuries B.C. Decorated situlae and other pieces of 'situla art' were found at this most important archaeological site, in addition to many bronze and iron objects, bronze helmets of various types, some imported vessels and a great number of amber and glass beads.

2004, 194 pp., 12 b/w photos + 174 plates + 13 supplements, 25 x 33.5 cm, hardcover, ISBN 961-6169-31-9.

Price: EUR 59.

Orders: Narodni muzej Slovenije, Prešernova 20, SI-1000 Ljubljana, Slovenia; or: blagajna@narmuz-lj.si





Založba ZRC / ZRC Publishing
<http://zalozba.zrc-sazu.si>
ISSN 1408-5208
ISBN 978-961-254-400-3



9 789612 544003

57 €