

Povečanje signala nihanja kotalnih ležajev z uporabo prilagodljive krmilne zanke za zmanjševanje šuma

Enhancing the Vibration Signal from Rolling Contact Bearing Using an Adaptive Closed-Loop Feedback Control for Wavelet De-Noiseing

Jorge P. Arenas

Predstavljenih je bilo že več metod s področij časa in frekvence za nadzorovanje razmer in ugotavljanje napak na opremi oz. postopkih. Nadzorovanje in ugotavljanje izvajamo z analizami in tolmačenjem signalov, pridobljenih z zaznavali in pretvorniki. Vendar pa vsako notranje nihanje, ki se prenaša preko sosednjih teles, v ozadju povzroči nihanje, v katerem se signal, ki ga potrebujemo za analize, pogosto izgubi, še posebej v zgodnejši fazi nastanka napake. Če je šumnost nihanja v ozadju prevelika oz. je signal nihanja ležajev premajhen, so lahko običajne metode, kot npr. analiza zmanjševanja šuma valovanja, neučinkovite pri izničenju šuma takih signalov.

V prispevku smo predstavili kombinacijo povečanja prilagodljivega signala in spremembo valovanja za zmanjšanje šuma signala nihanja, izmerjenega na kotalnih ležajih. Kot postopek prilagodljivega utežnega krmiljenja smo uporabili algoritma normaliziranega najmanjšega srednjega kvadrata in rekurzivnih najmanjših kvadratov. Končni namen prilagodljivega filtra je bil zmanjšanje srednje kvadratične vrednosti signala napake, kar pomeni povečanje razmerja izstopnega signala in šuma sistema. Rezultati so pokazali, da povečanje prilagodljivega signala nihanja in sprememba valovanja povzročita najboljše razmerje signala in šuma. Kar pomeni, da lahko rezultat odkrije skrite sestave signala, ki so povezane neposredno z notranjimi okvarami v ležajih.

© 2005 Strojniški vestnik. Vse pravice pridržane.

(Ključne besede: ležaji kotalni, signali nihanja, analize šuma, zanke krmilne)

Several techniques in both the time and frequency domains have been reported for the condition monitoring and fault diagnosis of equipment and processes. The monitoring and diagnosis is accomplished through the analysis and interpretation of signals acquired from sensors and transducers. However, any structure-borne vibration propagated through the neighbouring structures will produce a background vibration in which the required vibration signals for the diagnosis are often submerged, in particular during the early stage of failure development. If the background-noise level is too high or when the bearing vibration signature level is too low, traditional techniques such as wavelet de-noising analysis can be ineffective in cancelling the noise of such signals.

In this paper the combination of an adaptive signal enhancement and the wavelet transform for de-noising a vibration signal measured on a rolling contact bearing is presented. The normalized least mean-square and recursive least-square algorithms were used as the adaptive weight-control mechanism. The final aim of the adaptive filter was to minimize the mean-square value of the error signal, which implies the maximization of the output signal-to-noise ratio of the system. The results showed that a combination of the adaptive vibration signal enhancement and the wavelet transform yielded the best signal-to-noise ratio. This means that the result can reveal hidden signal structures that are directly associated with a bearing's internal defect.

© 2005 Journal of Mechanical Engineering. All rights reserved.

(Keywords: rolling contact bearings, vibration signals, noise analysis, feedback control)

0 INTRODUCTION

The condition monitoring and fault diagnosis of equipment and processes are of great practical concern. Several techniques in both the time and frequency domains have been reported for this purpose [1]. Mechanical condition monitoring is concerned with the evaluation of the operating conditions of a machinery system or its components. The main purpose of the condition monitoring is to detect the presence of faults and damage in machinery during operation. It encompasses both diagnosis and prognosis in order to determine the remaining safe operating life of a machine before a breakdown or failure occurs [2].

Any operation of machinery involves the generation of forces that produce vibrations. Even a machine in good running order produces its own characteristic vibration, caused by the various dynamic forces associated with its operation.

Some of the most important components in rotating machinery are the bearings, of which the rolling-contact type are the most commonly used. Rolling element bearings have some unique concerns, which are not found in journal bearings. They are a result of the rolling elements being contained between the inner and outer raceways. The rolling elements are normally kept from touching each other by a cage. Because of the metal-to-metal contact, this bearing provides very little vibration damping. Therefore, rolling element bearings, as a result of their design and installation, provide a very good signal transmission path from the vibration source to the outer bearing housing. Although these bearings are very precisely machined parts some defects reduce their service life severely and can cause the breakdown of rotating machinery. Each component of the bearing will generate specific frequencies as the defects initiate and become more prevalent.

Bearing-element rotations generate vibrational excitation at a series of discrete frequencies that are a function of the bearing geometry – roller diameter, pitch diameter of the bearing, contact angle between the rolling element and the raceway, number of rolling elements – and the shaft's rotational speed. In addition to these discrete frequencies their harmonics will also be excited. However, there are three major frequencies that are commonly identified and associated with defective bearings: 1) the rolling-element pass frequency on the outer race, which is associated with an outer race defect, 2) the

rolling-element pass frequency on the inner race, which is associated with inner-race defects, and 3) the rolling-element spin frequency, which is associated with ball or ball-cage defects. Given the geometry of the bearing, the values for the discrete frequencies have been summarized by Shahan and Kamperman [3].

Localized defects such as a surface crack are a typical failure form in rolling-element bearings. The vibration generated in a normal bearing is usually dominated by the components caused by shaft rotation, stiffness variation, load fluctuation, etc. When a localized defect is induced, repeated impacts will be generated due to the passing of the rolling elements over the defect.

The condition monitoring and fault diagnosis in the machinery is accomplished through the analysis and interpretation of the signals acquired from sensors and transducers. The impacts have a wide-band energy that often sets off some modes of resonance with the bearing elements. This process adds additional impulsive components to the vibration and results in vibration signals of a non-stationary nature. Wavelet analysis has been shown to be a promising tool to overcome this problem. Several wavelet-based techniques have been presented for the feature enhancement and feature extraction of transient signals [4]. These techniques are much more effective than traditional techniques and have been successfully used in the condition monitoring and fault diagnosis of mechanical systems [5].

However, any structure-borne vibration propagated through neighbouring structures will produce a background vibration in which the required vibration components for diagnosis are often submerged, in particular during the early stage of failure development. If the background noise level is too high or when the bearing vibration signature level is too low, traditional techniques such as wavelet de-noising analysis are often ineffective in cancelling the noise of such signals. Therefore, enhancing the signals before de-noising to extract the frequency components is a very important task in detecting the defect.

Moreover, for model-based identification methods in the frequency domain it has been established that its performance can be affected by errors and the results might not be accurate. Recently, Vania and Pennacchi [6] have mentioned the random/bias errors in the vibration data as a source of inaccu-

racy. This means that a source of error for the identification methods can be the presence of noise in the vibration signals or errors in the order analysis. In this work, an adaptive closed-loop feedback control was applied to a bearing vibration signal buried in a background vibration noise in order to enhance this signal before applying a wavelet de-noising method to identify the frequency components of the rolling contact bearing.

1 THEORY OF ADAPTIVE FILTERING

If accurate information about the signals to be processed is available, the designer can easily choose the most appropriate algorithm to process the signal. When dealing with signals whose statistical properties are unknown, fixed algorithms do not process these signals efficiently. The solution is to use an adaptive filter that automatically changes its characteristics by optimising the internal parameters. These adaptive filtering algorithms are essential in many statistical signal-processing applications. The complete specification of an adaptive system consists of three items [7]: 1) the application, defined by the choice of the signals acquired from the environment to be the input and desired output signals, 2) the adaptive filter structure (FIR, IIR), and 3) the algorithm.

The most widely used adaptive FIR filter structure is the transversal filter, also called the tapped delay line, that implements an all-zero transfer function. For this realization, the output of the filter $y[n]$ is a linear combination of the filter coefficients, which yields a quadratic mean error ($MSE = E\{|e[n]|^2\}$, where $E\{\}$ denotes the statistical expectation operator) function with a unique optimal solution.

Typical impulse responses of ideal filters approach amplitudes of zero exponentially over time. Approximate realizations are thus possible with finite-length FIR filters. Of course, non-causal filters are not physically realizable in real-time systems. However, in many cases they can be realized approximately in delayed form, providing an acceptable, delayed real-time response. In practical circumstances, excellent performance can be obtained with two-sided filter impulse responses, even when they are truncated in time to the left and right. Using the delay, the truncated response can be made causal and physically realizable [8].

The usual method of estimating a signal corrupted by additive noise is to pass the compos-

ite signal through a filter that tends to suppress the noise, while leaving the signal relatively unchanged. The design of such filters is the domain of optimal filtering, which originated with the pioneering work of Wiener [9].

Noise cancelling is a variation of optimal filtering that is highly advantageous in many applications. It uses an auxiliary or reference input derived from one or more sensors located at points in the noise field where the signal is weak or undetectable. This input is filtered and subtracted from a primary input containing both signal and noise. As a result, the primary noise is attenuated or eliminated by cancellation.

If filtering and subtraction are controlled by an appropriate adaptive process, noise reduction can, in many cases, be accomplished with little risk of distorting the signal or increasing the output noise level. In circumstances where adaptive noise cancelling is applicable, it is often possible to achieve a degree of noise rejection that would be difficult or impossible to achieve by direct filtering [10].

In the signal-enhancement application the reference signal consists of a desired signal $x[n]$ that is corrupted by an additive noise $N_1[n]$. The input signal of the adaptive filter is a noise signal $N_2[n]$ that is correlated with the interference signal $N_1[n]$, but uncorrelated with $x[n]$.

1.1 Normalized Least-Mean-Square

The least-mean-square (LMS) algorithm is a search algorithm in which a simplification of the gradient-vector computation is made possible by appropriately modifying the objective function. This algorithm is widely used in various applications due to its computational simplicity. The convergence characteristics of the LMS can be shown for a stationary environment and the convergence speed is dependent on the eigenvalue spread of the input-signal correlation matrix [11]. Other features of the LMS are an unbiased convergence in the mean to the Wiener solution and stable behaviour when implemented with finite-precision arithmetic.

The normalized least-mean-square (NLMS) algorithm uses a variable convergence factor that minimizes the instantaneous error. Such a convergence factor usually reduces the convergence time but increases the misadjustment. The NLMS algorithm usually converges faster than the LMS algorithm, due to the variable convergence. It is interest-

ing to note that the faster convergence of the NLMS algorithm has been noticed by many researchers in computer simulations, but never theoretically proven. It appears that Bitmead and Anderson [12] coined the name of the NLMS algorithm in 1980. The NLMS algorithm can be summarized by the following two equations:

$$e[n] = d[n] - \mathbf{w}^H[n] \mathbf{u}[n] \quad (1)$$

and

$$\mathbf{w}[n+1] = \mathbf{w}[n] + \frac{\mu}{\alpha + \|\mathbf{u}[n]\|^2} \mathbf{u}[n] e^*[n] \quad (2),$$

where $n=1, 2, \dots$, $e[n]$ is the error, $d[n]$ is the desired signal, $\mathbf{w}[n]$ is the vector of the filter coefficients (taps), $\mathbf{u}[n]$ is the vector of the input signal, α and μ are positive constants, the superscript H denotes the Hermitian transposition, the asterisk denotes a complex conjugation, and the norm in Eq. (2) corresponds to the Euclidean norm. It is clear that the NLMS algorithm alters the magnitude of the correction term without a change in its direction. Accordingly, it bypasses the problem of noise amplification that is experienced in the LMS algorithm when $\mathbf{u}[n]$ is large. However, in so doing it introduces a problem of its own, which is experienced for small $\mathbf{u}[n]$. This problem is overcome by using the positive constant α . Also, a sufficient condition for the NLMS algorithm to be convergent in mean square is that $0 < \mu < 2$ [13]. If no previous information for the values of \mathbf{w} is available, then it is usual to initialise the algorithm with $\mathbf{w}[0]=\mathbf{0}$.

1.2 Recursive Least-Squares

Least-squares algorithms aim at the minimization of the sum of the squares of the difference between the desired signal and the model filter output. When new samples of the incoming signals are received at every iteration, the solution for the least-squares problem can be computed in recursive form resulting in the recursive least-squares (RLS) algorithm. The RLS algorithm is known to pursue a fast convergence, even when the eigenvalue spread of the input-signal correlation matrix is large. Of course, this algorithm has excellent performance when working in time-varying environments. All these advantages come at the cost of increased computational complexity and some stability problems, which are not as critical in the LMS-based algorithms. Some

references mention that although the RLS does not attempt to minimize the mean-square error (in the ensemble-averaged sense), nevertheless, the mean-square value of the true estimation error converges within less than $2M$ iterations, where M is the number of taps coefficients in the tapped-delay-line filter [13]. The RLS algorithm, for $n=1, 2, \dots$, can be summarized by the following equations:

$$\mathbf{K}[n] = \frac{\mathbf{P}[n-1] \mathbf{u}[n]}{\lambda + \mathbf{u}^H[n] \mathbf{P}[n-1] \mathbf{u}[n]} \quad (3)$$

$$\xi[n] = d[n] - \mathbf{w}^H[n-1] \mathbf{u}[n] \quad (4)$$

$$\mathbf{w}[n] = \mathbf{w}[n-1] + \mathbf{K}[n] \xi^*[n] \quad (5)$$

$$\mathbf{P}[n] = \frac{\lambda}{\mathbf{P}[n-1] - \mathbf{K}[n] \mathbf{u}^H[n] \mathbf{P}[n-1]} \quad (6),$$

where λ is a constant, called the forgetting factor, which is close to but less than 1 and $\xi[n]$ is called the *a posteriori* error. The initialisation for the algorithm is $\mathbf{w}[0]=\mathbf{0}$ and for the matrix $\mathbf{P}[0]=\delta^{-1}\mathbf{I}$, where \mathbf{I} is the identity matrix and $\delta \ll 1$.

1.3 Wavelet de-noising

In several research fields, a common problem consists of recovering a true signal from incomplete, indirect or noisy data. The development of fast computers has allowed the practical implementation of wavelets that help in solving this problem, through a technique called wavelet shrinkage and thresholding methods [14]. The theory of wavelets can be found in several modern textbooks (for example, see [15]).

Decomposing a data set using a discrete wavelet transform (DWT) is analogous to using filters that act as averaging filters and others that produce details. Some details in the data set correspond to the resulting wavelet coefficients. These coefficients can be used later in an inverse wavelet transformation to reconstruct the data set. If the details in the data set are small, they can be omitted without substantially affecting the main features of the data set. Therefore, thresholding means to set to zero all the coefficients that are less than a particular threshold. This process generally gives a low-pass and smoother version of the original noisy signal. The objective of wavelet de-noising is to suppress the additive noise $N_1[n]$ from a signal $s[n]$, where $s[n]=x[n]+N_1[n]$. The signal $s[n]$ is first decomposed into the L -level of the wavelet transform. Then, for

noise suppression, the thresholding of the resultant wavelet coefficients is performed. The thresholding is based on a value δ that is used to compare with all the detailed coefficients. Two types of thresholding are more popular:

- 1) Hard thresholding, which is the usual process of setting to zero the coefficients whose absolute values are lower than the threshold,
- 2) Soft thresholding, which is an extension of hard thresholding by first setting to zero the coefficients whose absolute values are lower than the threshold and then shrinking the non-zero coefficients toward zero.

Then, in summary, the technique of wavelet de-noising consists of transforming, thresholding and inverse-transforming the signal. This technique has been very useful in handling noisy data because the de-noising is carried out without smoothing out the sharp structures. The result is a cleaned-up signal that still shows important details [16].

2 RESULTS

An experiment was conducted to acquire real signals for testing an adaptive rolling-contact-bearing vibration-signal enhancement system. The experimental scheme is shown in Fig. 1, where some of the blocks indicate the filtering process. The ball

bearing used for the test was a single-row radial ball bearing having 20 balls of 6 mm diameter, 45 mm bore diameter, and 57 mm pitch diameter of the ball races. The isolation of the rolling bearing to be analysed and the isolation of other parts of the machine were removed in order to increase the effect of the structure-borne noise vibration, which contaminated the signal of the bearing. The vibration produced by the bearing was sensed by means of an ICP accelerometer mounted on the bearing cover. A second ICP accelerometer was attached to a selected point on the test-rig base in order to measure the vibration reference signal. This point was located 40 cm from the bearing and 10 cm from the motor. Therefore, the accelerometer in the bearing sensed the real signal $x[n]$ plus the contaminating noise $N_1[n]$, and the second accelerometer sensed a reference signal $N_2[n]$. Both signals were digitally recorded simultaneously, using a sampling frequency of 1,024 Hz during 10 seconds, so the number of samples collected for each channel was 10,024. A multi-channel digital data-acquisition system was used for this purpose. To avoid aliasing, the signals were processed through low-pass filters with a cut-off frequency of 500 Hz. The signals were then saved as data files in order to be processed later in a workstation lab. The nominal rotational speed of the axis was 780 rpm (13 Hz).

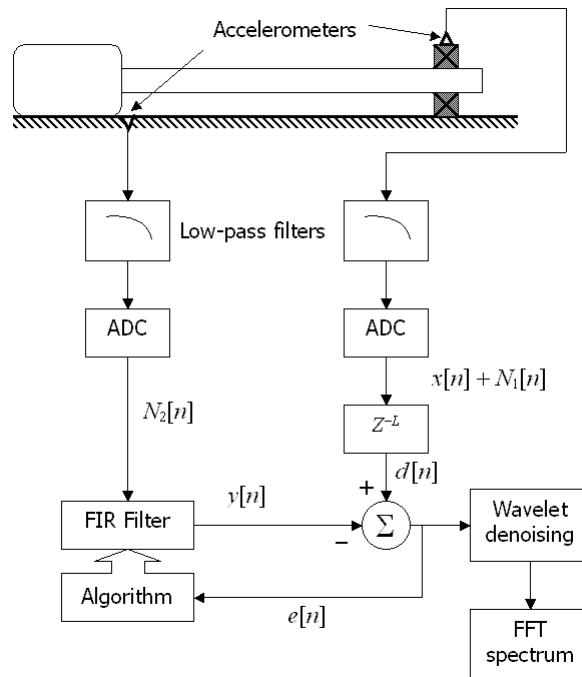

Fig. 1. Experimental set up

As can be seen from Fig. 1, the error signal for this application is given by

$$e[n] = x[n] + N_1[n] - y[n] = x[n] + N_1[n] - \sum_{k=1}^M w_k N_2[n-k] \quad (7),$$

where M is the number of filter coefficients (taps). Then, the resulting MSE (quadratic mean error for real values), is

$$MSE = E\{e^2[n]\} = E\{x^2[n]\} + E\{N_1[n] - y[n]\}^2 \quad (8),$$

where it has been assumed that $x[n]$ is uncorrelated with $N_1[n]$ and $N_2[n]$. Equation (8) shows that if the adaptive filter, having $N_2[n]$ as the input signal, is able to perfectly predict the signal $N_1[n]$, then the minimum value of MSE is given by

$$\eta_{\min} = E\{x^2[n]\} \quad (9),$$

where the error signal, in this situation, is the desired signal. The effectiveness of the signal enhancement scheme will depend on the correlation between $N_1[n]$ and $N_2[n]$. From Fig. 1 it can be seen that a delay Z^{-L} is applied to the input. In some applications it is recommended to include this delay of L samples in the reference signal or in the input signal, such that their relative delay yields a maximum cross-

correlation between $y[n]$ and $N_1[n]$, reducing the MSE [7]. This delay provides a kind of synchronization between the signals involved.

The NLMS and RLS algorithms presented in Eqs. (1)-(6) were implemented in a Matlab computer code to test the performance with the real data.

The following results were obtained with a 10-tap implementation of the adaptive FIR filter shown in Fig. 1. The NLMS and RLS algorithms were used as the adaptive weight-control mechanism.

Figure 2 shows the results of the time signatures at the input and at the output of the FIR filter using both NLMS and RLS adaptive algorithms.

For making a direct graphical comparison between the performance of the RLS and NLMS algorithms, the quadratic mean error (MSE) results are shown in Fig. 3. The optimal results for the NLMS algorithm were obtained using $\mu=0.09$ and a delay $L=5$. For the RLS algorithm the optimal results were achieved using $\lambda=0.999$ and a delay of $L=5$. It was impossible to find proper parameters in order to achieve the convergence at the output of the filter without using a delay at the input. From Fig. 3 it is observed that the MSE curves start at zero, rise to a peak, and then decay toward a steady-state value. In addition, it can be observed that the MSE curve for the RLS algorithm has the same general shape as that for the NLMS algorithm.

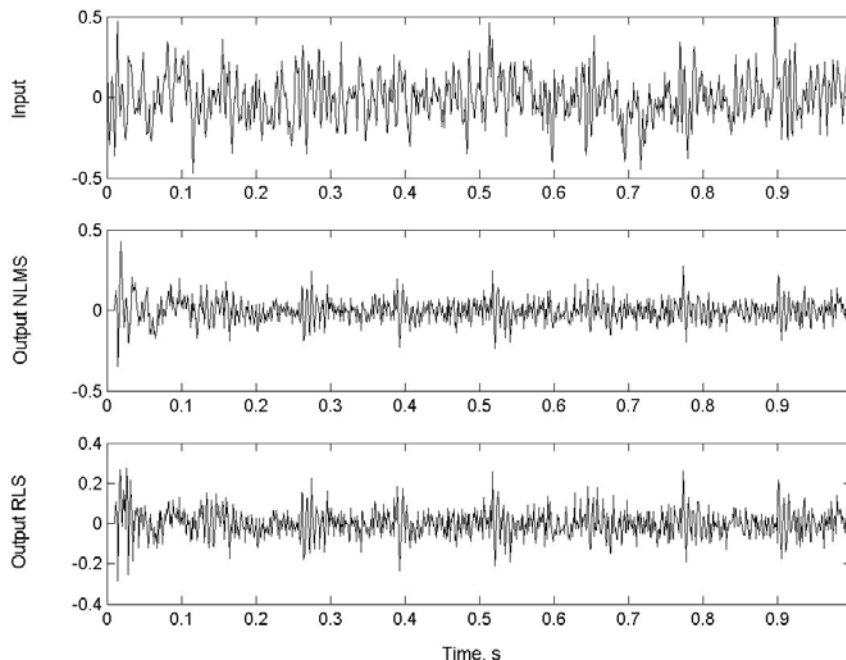

Fig. 2. Time signals at the input and at the output of the FIR filter using the NLMS and RLS adaptive algorithms

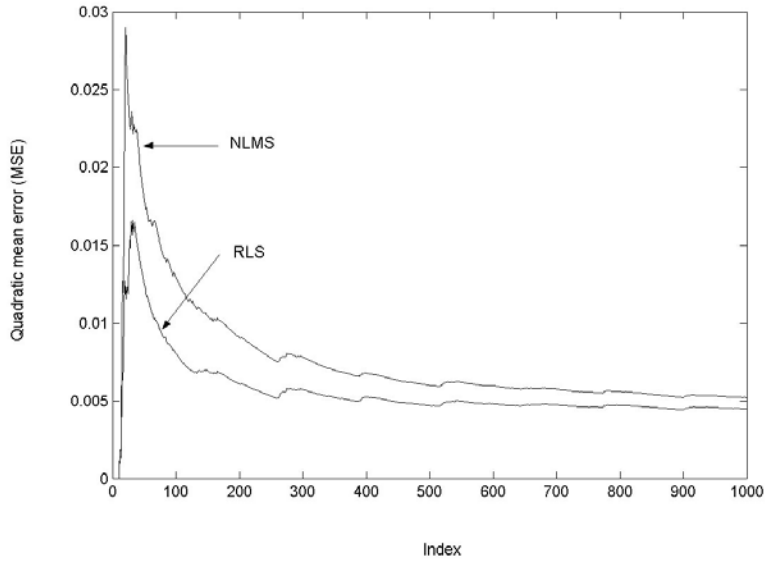

Fig. 3. Results of the quadratic mean error (MSE) for the RLS and NLMS algorithms

It is clear that the RLS algorithm shows faster convergence than the NLMS algorithm, which is usual for stationary signals [13]. However, other authors have reported the opposite when dealing with transient signals [17]. From the theory, however, a faster convergence was expected for both algorithms. This fact can be explained because there could be some small degree of correlation between the signal measured at the bearing and the reference signal, which could result in misadjustment.

In addition, wavelet transforms were used for de-noising the data. The data was transformed into an orthogonal wavelet basis. Thresholding was applied to shrink the noisy wavelet coefficients and then the modified wavelet coefficients were used to reconstruct the signal by the inverse wavelet transform. Several de-noising schemes were applied, using several wavelets and thresholding methods. For the de-noising process, the best results were obtained from the combination of the db4 (Daubechies

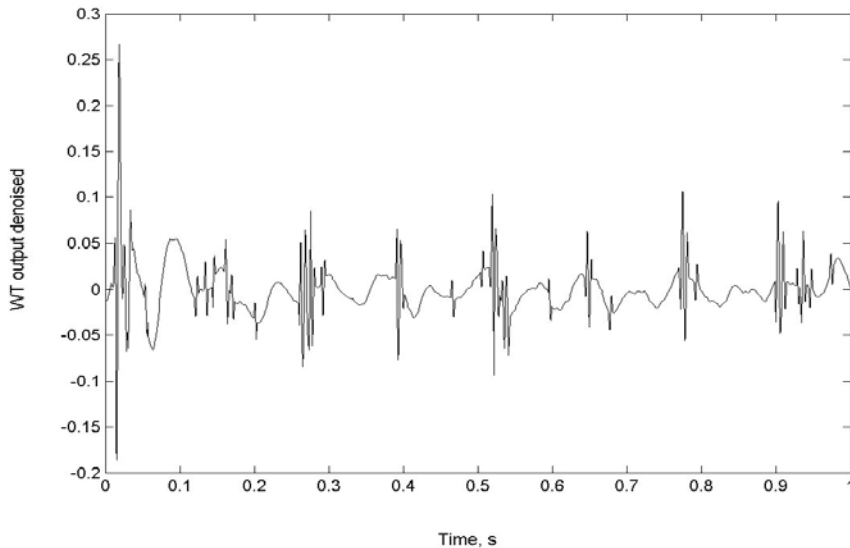

Fig. 4. Time signal obtained after using the adaptive filtering with the RLS algorithm and then de-noised by means of the wavelet transform (WT)

4) wavelet [18] and hard thresholding with an interval-dependent threshold setting.

Figure 4 shows the time signal obtained after using the adaptive filtering with the RLS algorithm and then de-noised by means of the wavelet transform (WT). It can be observed that the periodic details of the signal are now revealed, allowing a time waveform analysis.

In Fig. 5 the results of the fast Fourier transform (FFT) spectra are presented. Figure 5(A) shows the results without using any kind of noise cancellation. Figure 5(B) shows the results using a wavelet transform for de-noising the measured signal without using the adaptive FIR filtering. Finally, Fig. 5(C) presents the results when wavelet de-noising is applied after the signal has been enhanced using the adaptive FIR filter. Clearly, the best results are achieved when both adaptive filtering and wavelet de-noising techniques are applied, so the signal-to-noise ratio for all frequency regions is increased significantly. The upper end of the high-frequency range remained relatively clean due to the low levels of extraneous signal components in this region. Fig. 5(C) clearly shows the presence of a spike in the very-low-frequency region, which corresponds to the shaft's rotational speed (modulation frequency). Also, a spectral peak around 150 Hz and side-bands with a spacing of approximately 8 Hz are observed.

From the geometry of the bearing the ball pass frequency inner race (BPFI) is calculated to be approximately 144 Hz [3]. This means that the spectral peak might be indicating some inner race-bearing defect. The sidebands might be related to the cage frequency. One way to study this effect would be to change the rotational velocity of the shaft. Certainly, the resonances should disappear and only the forcing frequencies would remain.

3 CONCLUSIONS

The proposed technique constitutes a successful application of adaptive filtering combined with wavelet thresholding for vibration-signal enhancement when the useful vibration signatures become submerged within the noise and interference from external signals. For this particular application it can be concluded that the rate of convergence of the RLS algorithm is faster than that of the NLMS algorithm, but this is achieved at the expense of a large increase in computational complexity. In addition, the correct selection of the analysing wavelet with different properties is of critical importance for enhancing the fault features in the wavelet analysis.

When just using wavelet de-noising, significant gains in the signal-to-noise ratio are evident

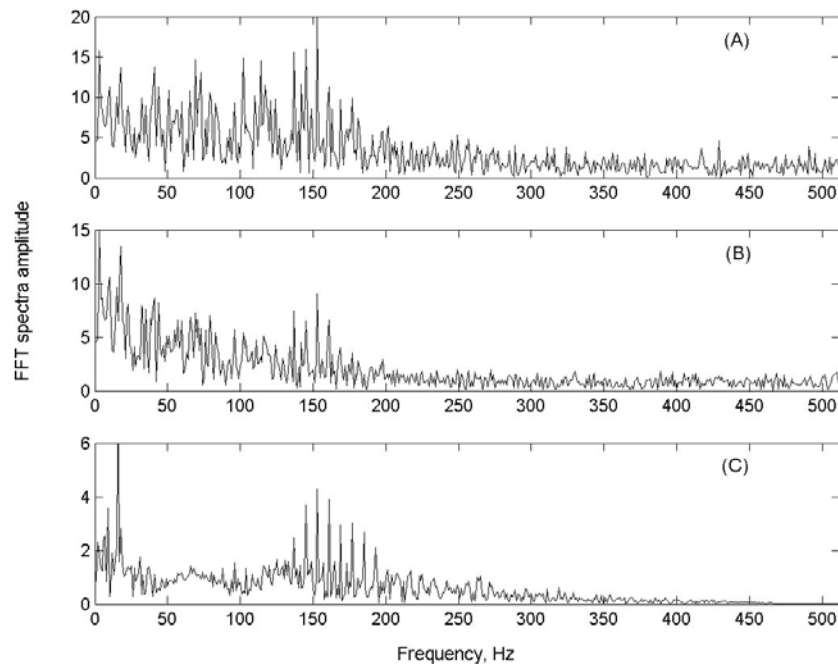

Fig. 5. Results of the FFT spectra: (A) without noise cancellation; (B) with wavelet de-noising; (C) with wavelet de-noising combined with adaptive FIR filter

compared to the direct FFT analysis of the noisy measured signal. However, more modest improvements are achieved when compared to the application of a previous adaptive signal enhancement of the measured signal. Used in conjunction with a wavelet de-noising analysis, the technique provides promising, enhanced diagnostic capabilities. The

extracted signal also provides a sensitive and accurate basis from which the severity of localised rolling-element bearing faults can be analysed.

Further research will investigate the improvement of the adaptive signal enhancement system by using several vibration reference sensors that will be mounted at various locations on the machine.

4 REFERENCES

- [1] Serridge, M. (1989) Fault detection techniques for reliable machine condition monitoring. *Sound and Vibration* 23(5), 18-22.
- [2] Krishnappa, G. (1997) Machinery condition monitoring, in Encyclopedia of Acoustics (Edited by M.J. Crocker), *John Wiley and Sons*, New York.
- [3] Shahan, J.E., G. Kumperman (1976) Machine element noise, in Handbook of Industrial Noise Control (Edited by L.L. Faulkner), *Industrial Press*, New York.
- [4] Altmann, J., J. Mathew (2001) Multiple band-pass autoregressive demodulation for rolling-element bearing fault diagnosis. *Mechanical Systems and Signal Processing* 15(5), 963-977.
- [5] Liu, B., S.F. Ling (1999) On the selection of informative wavelet for machinery diagnosis. *Mechanical Systems and Signal Processing* 11(3), 145-162.
- [6] Vania, A., P. Pennacchi (2003) Experimental and theoretical application of fault identification measures of accuracy in rotating machine diagnostics. *Mechanical Systems and Signal Processing* (in press).
- [7] Diniz, P. (1997) Adaptive filtering: algorithms and practical implementation, *Kluwer Academic*, Norwell, MS.
- [8] Widrow, B, S.D. Stearns (1985) Adaptive signal processing, *Prentice Hall*, Englewood Cliffs, NJ.
- [9] Wiener, N. (1949) Extrapolation, interpolation, and smoothing of stationary time series, with engineering applications, *MIT Press*, Cambridge, MS.
- [10] Widrow, B., J. Glover, J. McCool, J. Kaunitz, C. Williams, R. Hearn, J. Zeidler, M. Dong, R. Goodlin (1975) Adaptive noise cancelling: principles and applications. *Proc. of IEEE* 63(1), 1692-1716.
- [11] Haykin, S. (1984) Introduction to adaptive filters, *Macmillan Publ. Co.*, New York.
- [12] Bitmead, R.R., B.D.O. Anderson (1980) Performance of adaptive estimation algorithms in dependent random environments. *IEEE Trans. Automatic Control* AC-25, 782-787.
- [13] Haykin, S. (1996) Adaptive filter theory, 3rd Edition, *Prentice Hall*, Englewood Cliffs, NJ.
- [14] Donoho, D.L. (1995) De-noising by soft-thresholding. *IEEE Trans. Information Theory* 41(3), 613-627.
- [15] Barbara, B.H. (1998) The world according to wavelet: the story of a mathematical technique in the making, *A.K. Peters Ltd.*, Wellesley, MA.
- [16] Pan, Q., L. Zhang, G. Dai, H. Zhang (1999) Two denoising methods by wavelet transform. *IEEE Trans. Signal Processing* 47(12), 3401-3406.
- [17] Bershad, N., O. Macchi (1989) Comparison of RLS and LMS algorithms for tracking a chirped signal. *Proc. Int. Conf. on Acoustics, Speech and Signal Processing ICASSP89*, 896-899.
- [18] Daubechies, I. (1990) The wavelet transform, time-frequency localisation and signal analysis. *IEEE Trans. Information Theory* 36(5), 961-1005.

Authors Address: Prof.Dr. Jorge P. Arenas
 Institute of Acoustics
 University Austral of Chile
 P.O. Box 567
 Valdivia, Chile
 jparenas@uach.cl

Prejeto: 5.11.2003
 Received:

Sprejeto: 2.12.2004
 Accepted:

Odprto za diskusijo: 1 leto
 Open for discussion: 1 year