

ROOT WELD METAL IMPACT TOUGHNESS OF AN ENERGY COMPONENT

UDARNA ŽILAVOST V KORENU ZVARA ENERGETSKE KOMPONENTE

Julijan Salamunič[✉]

Keywords: steel, root weld metal, impact toughness, welded joints

Abstract

In energy engineering, high-strength low-alloy steels are used for building high-loaded modern constructions. The weakest link of a welded structure is a welded joint at which cracks appear, which can lead to sudden destruction. Thus, the welded joints are made with a high impact toughness that can prevent unstable crack propagation.

This research deals with the experimental determination and analysis of Charpy impact toughness curves at the weld root of an energy component for different additive materials.

Povzetek

V energetiki uporabljamo visokotrnostna malolegirana konstrukcijska jekla za gradnjo visoko obremenjenih modernih konstrukcij. Najšibkejši člen varjene konstrukcije je zvarni spoj v katerem se pojavljajo razpoke, ki lahko povzročijo nenadno porušitev. Zaradi navedenega gradimo zvarne spoje tako, da imajo zvari visoko udarno žilavost, ki lahko zadržijo nestabilno širjenje razpok.

V raziskavi je predstavljena eksperimentalna določitev in analiza krivulj Charpyjeve udarne žilavosti v korenu zvara energetske komponente za različne dodajne materiale.

✉ Corresponding author: Ph.D. Student, Julijan Salamunič, Faculty of Energy Technology, University of Maribor,
Tel.: +386 (0)3-7770-400, Mailing address: Koroška cesta 62a, Velenje, Slovenia, E-mail address: julko.julko@gmail.com

1 INTRODUCTION

A welded joint is a critical part of any welded construction because with the introduction of heat into the base material (BM) during welding the mechanical properties of the base material (the construction steel) can be worsened. A welded joint consists of a weld and on both sides the so-called heat affected areas (HAA). There are two types of welded joints: joints where the weld strength is lower than the base material. Such joints are called low-strength welded joints. The so-called high-strength welded joints occur when we build a weld material with a higher yield strength than the base material has. It is known that the high-strength low-alloy (HSLA) steels are problematic for welding which means that they require a specially prescribed welding technology. Most often such steels are welded by preheating and with smaller energy inputs in a way that we make a multi-welded weld connection with thinner wedges. Moreover, cracks endanger the safety of the entire weld construction because they can cause a collapse due to a sudden overload. That is why a welded joint has to have good mechanical properties, the most important of which is the impact toughness which is determined experimentally with the standard dynamic Charpy test. Most errors, while welding of HSLA steel, occur during and after the welding, namely at the weld root, which is the critical point of a welded joint and must have a high impact toughness. Due to the above, it is extremely important that prior to building a high strength construction, we must test the welded joints that are welded with various additive materials [1-5].

This article examines HSLA steel of strength class SC 50, of the manufacturer Železarna Jesenice and the additive materials of Elektroda Jesenice. The welded joints are welded with eight different additive materials in such a way that they form a low-strength welded joint. The impact toughness of the weld root is determined with the standard dynamic Charpy test. The analyses of the whole curve of impact toughness are given with the emphasis on the part of the curve that shows the lowest impact toughness: the so-called brittle area of the curve. For the root part of the weld, the microstructures are determined [7-8].

2 MATERIALS AND MECHANICAL PROPERTIES

We chose the improved HSLA steel Niomol 490K, strength class 50 and 40mm thick, from the Slovene manufacturer Acroni Jesenice, for the welding of the high-strength welded joint. Welding took place at the company Goršek d.o.o., Šentjanž. The steel was not preheated since we decided to weld with low-strength additive materials that have a lower limit of flow than the base material; that is why preheating was not necessary, which also reduces the costs of the production of welded joints. The heat input was 15kJ/cm of the weld; the cooling time was $\Delta t_{8/5} = 9s$.

The X welding form was suitable for welding, and the result of a multi-welded X weld joint can be seen in Figure 1.



Figure 1: X form of a multi-welded weld joint

A lower strength weld was welded with eight various additive materials:

- welding wire VAC 60 and VAC 65
- coated basic electrode EVB 50 and EVB 55
- coated basic electrode EVB Ni and EVB S
- filled wire Filtub 28B
- coated basic electrode EVB NiMo.

Mechanical properties of the base material and the additive materials are given in Table 1.

Table 1: Mechanical properties of the base material and the additive materials

Welded joint Additive materials/BM	R _p [MPa]	R _m [MPa]	A _{gt} [%]	E [GPa]	n
VAC 60/Niomol	475	564	13.43	210	0.144422
VAC 65/Niomol	488	597	13.54	211	0.140573
EVB 50/Niomol	511	603	12.52	221	0.134246
EVB 55/Niomol	501	578	12.33	205	0.136926
EVB S/Niomol	432	555	15.68	208	0.158796
EVB Ni/Niomol	563	676	11.73	210	0.121847
EVB NiMo/Niomol	535	686	12.86	207	0.128224
Filtub 28 B/Niomol	537	625	11.79	209	0.127746
Base material NIOMOL 490K	606	680	10.03	201	0.113201

Here are the basic characteristics of the additive materials:

VAC 60: Coppered welding wire/welding rod according to MAG procedure. It is suitable for welding of non-alloy steels and low-alloy steel up to 530 Mpa. It is used for welding of boiler plates, pipes, steels for shipbuilding, micro-alloy steels and steel castings. VAC 60 was tested according to the CTOD method.

VAC 65: Coppered welding wire/welding rod according to MAG procedure. The content of Si and Mn is slightly higher than in VAC 60; therefore, the yield strength and the strength of the solid weld are also higher. The increased level of Si also reduces the sensitivity to surface impurities and provides a smooth weld. It is suitable for the welding of non-alloy steels and low alloy steel up to 640 Mpa. It is used for welding of boiler plates, pipes, steels for shipbuilding, micro-alloy steels, and steel castings. VAC 65 was tested according to the CTOD method.

EVB 50: Basic, CTOD-tested electrode for welding of non-alloy and low-alloy steels and steel castings up to 610 Mpa, as well as for welding of fine-grained steels with increased strength. Welds are tough even at low temperatures and resistant to cracks. The content of hydrogen is lower than 5 ml/100g of the weld. The electrode has excellent welding properties and a stable arc. The slag can be easily removed. It has 118% efficiency. The strength of the welding current in different positions does not necessarily need to be changed.

EVB 55: Basic, CTOD-tested electrode, especially suitable for welding of low-alloy steels and carbon steels containing up to 0.6% of carbon. The welds are resistant to hot-cracking and have a low content of dissolved hydrogen, as well as high toughness even at low temperatures and aging resistance. The electrode has very good welding properties; slag can be removed easily and with minimal spraying.

EVB S: Double-coated basic, CTOD-tested electrode with very good welding properties in forced positions. The electrode has a very stable arc. It is suitable for the welding of root welds with direct and alternating current.

EVB Ni: With Ni alloyed, basic, CTOD-tested electrode for the welding of non-alloy and low alloy steels up to 685 Mpa and fine-grained steel with limits up to 800 Mpa and with guaranteed mechanical properties at low temperatures. The weld toughness at low temperatures is very good.

EVB Ni-Mo: With Ni and Mo alloyed, a basic electrode for welding of steels with increased resistance to atmospheric corrosion and for welding of fine-grained steels with limits up to 460 Mpa

Filtub 28B: High-frequency firing wire, CTOD-tested, alloyed with Mn, Ni, and Mo, suitable for welding fine-grained steels of tensile strength up to 750 Mpa. Welding with this wire shows excellent mechanical properties at low temperatures, minimal spraying at welding, smooth surface of the weld and easy slag removal.

3 EXPERIMENTAL PROCEDURE

The Charpy test is thoroughly described in Chapter 3. Charpy samples were taken from the weld root as shown in Figure 2.

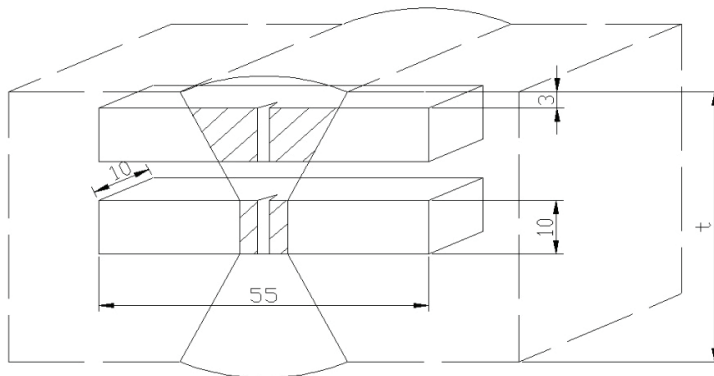

Figure 2: The removal of Charpy samples from the weld root; the possible removal of samples from the cap of the weld are indicated

The Charpy experiment was carried out at temperatures of -60, -50, -40, -30, -20, -10, 0, +10, and +20 °C, in which three test samples were prepared for each test temperature. The results of impact toughness in tabular form are shown in Table 2 [8-11].



Figure 3: The appearance of the manufactured and broken Charpy samples



Figure 4: The appearance of the groundbreaking surface of the Charpy sample

Table 2: The results of impact toughness for additive materials EVB 55, EVB NiMo, Filtub 28B, EVB Ni, EVB 50, EVB S, VAC 65 and VAC 60

EVB 55

Temp-60	-50	-40	-30	-20	-10	0	10	20
72	78	86	88	108	112	123	160	165
80	88	99	78	78	128	140	151	140
64	62	70	110	99	96	80	95	129
						114.333	135.333	144.666
72	76	85	92	95	112	3	3	7

FILTUB 28B

Temp-60	-50	-40	-30	-20	-10	0	10	20
50	64	61	74	80	61	91	119	121
42	94	50	59	89	95	58	142	81
71	47	70	96	40	122	120	79	100
54.3333	68.3333	60.3333	76.3333	69.6666	92.6666	89.6666	113.333	100.666
3	3	3	3	7	7	7	3	7

EVB Ni

Temp-60	-50	-40	-30	-20	-10	0	10	20
62	76	71	88	69	79	92	100	110
48	96	59	78	81	61	115	138	129
33	60	62	91	88	25	62	172	185
47.6666	77.3333		85.6666	79.3333		89.6666	136.666	141.333
7	3	64	7	3	55	7	7	3

EVB 50

Temp-60	-50	-40	-30	-20	-10	0	10	20
31	50	68	80	94	105	118	131	178
42	62	58	71	81	138	158	185	199
47	46	42	65	64	81	75	172	101
	52.6666			79.6666			162.666	159.333
40	7	56	72	7	108	117	7	3

EVB S

Temp-60	-50	-40	-30	-20	-10	0	10	20
25	32	39	46	56	85	82	108	134
38	38	45	58	71	100	115	138	165
30	19	30	35	31	63	91	75	95
	29.6666		46.3333	52.6666	82.6666			131.333
31	7	38	3	7	7	96	107	3

VAC 65

Temp-60	-50	-40	-30	-20	-10	0	10	20
35	41	49	55	79	84	90	115	121
47	49	53	65	100	110	121	91	143
21	31	29	42	41	61	141	151	181
34.3333	40.3333	43.6666		73.3333		117.333		148.333
3	3	7	54	3	85	3	119	3

VAC 60

Temp-60	-50	-40	-30	-20	-10	0	10	20
32	42	54	62	65	90	110	130	121
38	48	65	85	105	128	141	161	143
30	20	50	31	75	78	61	100	165
33-	36.6666	56.3333	59.3333	81.6666	98.6666		130.333	
33333	7	3	3	7	7	104	3	143

EVb Ni-Mo

Temp-60	-50	-40	-30	-20	-10	0	10	20
48	61	63	69	83	90	101	125	142
37	55	46	74	61	71	82	93	132
30	50	59	81	75	86	94	110	137
38.3333	55.3333		74.6666		82.3333	92.3333	109.333	
3	3	56	7	73	3	3	3	137

At each test, temperature mean values were calculated, through which the polynomial approximation was carried out to obtain a smooth curve of impact toughness. The curves of impact toughness for additive materials EVB 55, EVB NiMo, Filtub 28B, EVB Ni, EVB 50, EVB S, VAC 65, and VAC 60 are shown in Figure 5.

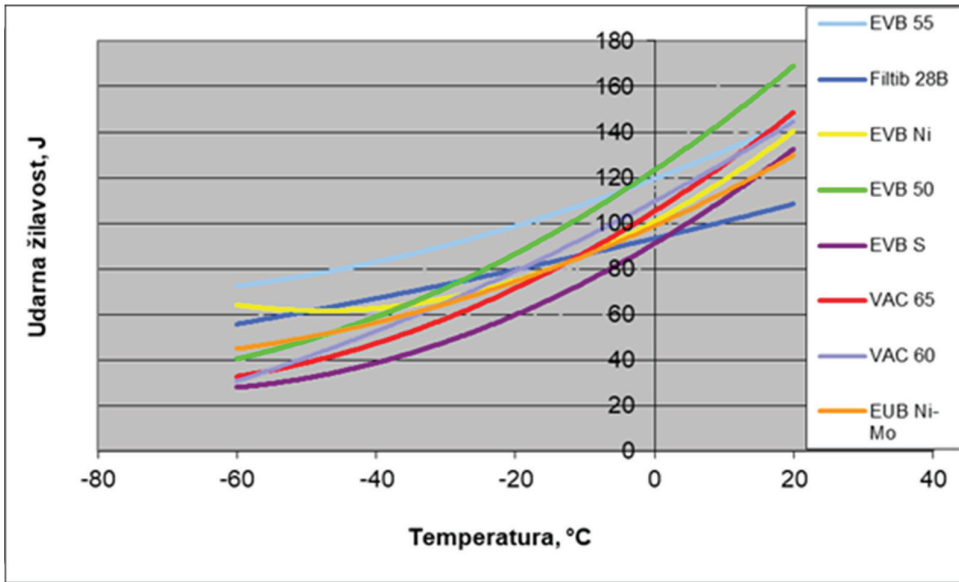

Figure 5: The curves of impact toughness at the weld root for additive materials EVB 55, EVB NiMo, Filtub 28B, EVB Ni, EVB 50, EVB S, VAC 65, and VAC 60

4 ANALYSIS OF RESULTS

The classification of impact toughness curves in the weld root for additive materials EVB 55, EVB NiMo, Filtub 28B, EVB Ni, EVB 50, EVB S, VAC 65 and VAC 60 is shown in Figure 2. There we can see that the curves are not evenly distributed, but they intersect each other. This finding shows the complexity of the problem of determining impact toughness in welded compounds which are highly heterogeneous microstructures.

The highest impact toughness can be seen in the weld that was welded with the EVB 55 electrode, in the temperature range from $-60\text{ }^{\circ}\text{C}$ to $-5\text{ }^{\circ}\text{C}$, and the lowest impact toughness in the weld that was welded with the EVB S electrode in the temperature range from $-60\text{ }^{\circ}\text{C}$ to $+5\text{ }^{\circ}\text{C}$. All eight curves of impact toughness in the temperature range from $-40\text{ }^{\circ}\text{C}$ to $+20\text{ }^{\circ}\text{C}$ exceeded 28 J for fracture, which indicates that the toughness of all eight welds is sufficient for the construction of welded joints with the required welding technology on the field.

Only the curve of impact toughness for the weld that was welded with the EVB S electrode for the temperature range from $-60\text{ }^{\circ}\text{C}$ to $-40\text{ }^{\circ}\text{C}$ did not exceed the minimum required toughness of 28 J. Good toughness at lowest temperatures is the most important.

Thus, as we can see from the distribution of the curves for the impact toughness that in the temperature range from $-60\text{ }^{\circ}\text{C}$ to $-20\text{ }^{\circ}\text{C}$ the weld made with the EVB S electrode has the lowest toughness (but still higher than 28 J), Followed by welds made with electrodes VAC 65, VAC 60, EVB 50, and Filtub 28B. The highest impact toughness is with the weld made with the EVB 55 electrode.

From the distribution of the curves of impact toughness, we can see that the curve of impact toughness for the weld made with the EVB Ni electrode has strikingly high growth, namely in the

temperature range from $-60\text{ }^{\circ}\text{C}$ to $-40\text{ }^{\circ}\text{C}$ where it has a higher impact toughness at $-60\text{ }^{\circ}\text{C}$ than at $-40\text{ }^{\circ}\text{C}$. We should look for the cause of this anomaly in the actual location of the notch. It is certain that in the case of higher toughness at the lower temperature of $-60\text{ }^{\circ}\text{C}$ the notch was placed in the tougher bainite microstructure of the weld, whereas in the case of lower toughness at $-40\text{ }^{\circ}\text{C}$ the notch was placed in a more brittle coarse-grained ferrite-bainite microstructure of the weld.

Precisely because of the aforementioned problem of notch placement, we did a metallographic survey of microstructures that appeared after welding at the root of the hardened weld and are shown in Figures 3-6. Figure 1 shows the most favourable and toughest microstructure of the base material, Niomol 490-K steel. Fine-grained bainite microstructure at the weld root is the cause for attaining the highest impact toughness of the weld made with the EVB 55 electrode. Moreover, in contrast, the reason for the lowest impact toughness for the weld made with the EVB S electrode was the less tough coarse-grained ferrite microstructure.

Due to the anticipated construction of lower strength welds, a micro-hardness test at the weld root of all eight welded joints was performed. The distribution of hardness inequality coefficients at the weld root that was welded with additive materials EVB 55, EVB NiMo, Filtub 28B, EVB Ni, EVB 50, EVB S, VAC 65, and VAC 60 (Figure 1-8) proves that, even after welding, all weld roots showed a factor of hardness inequality M lower than 1, which means that all actual weld roots are in the low-hardness area. With this finding, the prescribed welding technology is confirmed as the correct one.

5 CONCLUSIONS

The Charpy impact test is a standardized impact toughness test and is carried out with the Charpy hammer. It is mandatory for the construction of pressure vessels (reactors, pipelines, reservoirs, etc.) and other complex welded constructions in the energy sector.

The stiffly lower weld was welded with eight different additive materials: welding wires VAC 60 and VAC 65, coated basic electrodes EVB 50 and EVB 55, coated basic electrodes EVB Ni and EVB S, filled wire Filtub 28B and coated basic electrode EVB NiMo.

The highest impact toughness was seen in the weld root made with the EVB 55, in the temperature range from $-60\text{ }^{\circ}\text{C}$ to $+5\text{ }^{\circ}\text{C}$. All eight curves of impact toughness, at the temperature range from $-40\text{ }^{\circ}\text{C}$ to $+20\text{ }^{\circ}\text{C}$, exceeded the energy of 28 J for fracture, which indicates that the toughness of all eight welds is good enough for making welded joints on an actual construction with the prescribed welding technology. Good toughness at negative/lower temperatures is the most important.

Due to the complexity of determining impact toughness in an extremely heterogeneous weld root, an analysis of microstructures in the weld root and base material is necessary. It was carried out with an optical microscope and according to the classification of end microstructures in the hardened weld (International Institute of Welding). Metallographic research showed two key microstructures, the so-called fine-grained bainite microstructure and coarse-grained ferrite microstructure. Some weld roots contained a mixed ferrite-bainite microstructure.

The distribution of the hardness inequality coefficients at the weld root welded with additive materials EVB 55, EVB NiMo, Filtub 28B, EVB Ni, EVB 50, EVB S, VAC 65, and VAC 60 (Figure 1-8) proves that, even after welding, all weld roots showed a factor of hardness inequality M lower

than 1, which means that all actual weld roots are in the low-hardness area. With this finding, the prescribed welding technology is confirmed as the correct one. In practice, this means that we can make such welds without using preheating, which strongly reduces the costs of making an welded joint.

References

- [1] **Z. Praunseis.**: Zapiski predavanj pri predmetu Optimiranje oskrbovalnih sistemov, Fakulteta za Energetiko, 2013
- [2] EN-875.: Standard method of Charpy Impact Toughness Test, London, 1993
- [3] **Z. Praunseis, J. Avsec.**: Gradniki v energetiki, Fakulteta za energetiko, Univerzitetni učbenik, 2011
- [4] **Z. Praunseis.**: Vpliv nižane trdnosti strjenega zvara z vključenimi heterogenimi področji na lomne lastnosti zvarnega spoja visokotrnostnega jekla, Univerza v Mariboru, Doktorska disertacija, 1998
- [5] **N. Gubelj.**: Celovitost konstrukcij, Univerza v Mariboru, Znanstvena monografija, 2006
- [7] **H. Granjon.**: Metalurške osnove varjenja, Zveza društev za varilno tehniko Slovenije, Ljubljana, 1994
- [8] <http://sl.wikipedia.org/wiki/SlikeNiko>
- [9] <http://sl.wikipedia.org/commons4746kerbschlagbiegeversuchMachine.jp>
- [10] **K. Easterling.**: Introduction to the Physical metallurgy of Welding, Butterworths, London etc., 1983
- [11] <http://lotric-certificiranje.si/laboratoriji/laboratorij-za-kovine-mehanske-preiskave-in-mikroskopijo/preskusi-udarne-zilavosti-na-preskusancih/> (2015)