

Hydraulic system for larger bailer press - design, production and commissioning

Aleš BIZJAK, Robert JURCA

Abstract: This article presents the project of a hydraulic system that drives a larger hydraulic bailer press. It describes all phases of the project from its design to its production, testing and commissioning.

The hydraulic system design follows strict demands in terms of machine productivity and reliability as well as the needs for compact design of hydraulic controls running at a fluid flow larger than 1500 L/min. Specific solutions have been chosen for the optimal utilization of available power to reach the highest possible actuator speed and force and also to assure a high level of energy efficiency.

Due to large fluid flow, hydraulic controls are designed with logic elements. But despite relatively complex schematics, all main control components are integrated into only one larger control manifold. This also nicely demonstrates the manifold design and production competences of Poclairn Hydraulics d.o.o. As it is usual for demanding machinery running in a more aggressive environment, more attention was paid to fluid cleanliness.

The complete hydraulic system was successfully delivered and commissioned. It is a result of our own competences in industrial hydraulic systems design as well as in the production and testing of complex control manifolds.

Keywords: bailer press, hydraulic system, design, production, commissioning

1 Introduction

Poclairn Hydraulics d.o.o. is a well-known and respected supplier with many years of experience and competences in industrial hydraulic systems design and production. Strong engineering and a production base located in Žiri, Slovenia, allow the implementation of projects for even most demanding customers.

Industrial hydraulic systems are usually built as open-loop stationary units driving industrial machinery. They can be designed as stand-alone units consisting of all

sub-systems except for actuators or with each sub-system as pump stations, hydraulic control manifolds and oil tank separately integrated into the machine.

Horizontal bailer presses are automatic machines used for compressing and packaging larger amounts of various materials. As high forces and long working strokes are needed



Figure 1. Poclairn Hydraulics d.o.o. plant in Žiri

Mag. Aleš Bizjak, univ. dipl. inž.,
Robert Jurca, univ. dipl. Inž.,
both Poclairn Hydraulics d.o.o.,
Žiri



Figure 2. Typical stand-alone design of hydraulic system

ded they are mostly hydraulically driven using one large main hydraulic cylinder which makes the compaction. They are built in different sizes with various options and adaptations to specific materials. Typically they are implemented into larger waste management facilities or near production lines generating a constant flow of waste material. Their productivity, efficiency and reliability play a crucial role for the users. That is why producers of bailer presses look for competent suppliers of hydraulic systems.

■ 2 Hydraulic system design

The hydraulic system is designed for flow exceeding 1500 L/min. It includes:

- pump unit with electronically controlled axial piston pump and additional fixed-displacement pump,
- main hydraulic control manifold driving main cylinder and pre-compression system,
- control manifolds for auxiliary functions,
- off-line filtration and cooling,
- oil tank with fluid control.

To fulfil the customer demands in terms of productivity and reliability at given power and space constraints, some specific engineering solutions were implemented:

- regenerative circuits for main cylinder and for pre-compressi-



Figure 3. Horizontal bailer press with feeding system

- on system – both differential, integration and connection of both regenerative circuits in one manifold to assure minimal dead stroke and return stroke time,
- counterbalance function implemented with logic elements,
- electronic p-Q control of input flow,
- soft shifting,
- cooling and filtration sub-system.

As some technical details are critical from the intellectual property standpoint, only general information about the hydraulic system and applied solutions will be presented in this article.

■ 2.1 Main hydraulic control manifold

The main hydraulic manifold per-

forms the function of two regenerative directional control valves – one for the main cylinder and one for the pre-compression system. Both directional valves are interconnected to assure the fastest possible dead stroke and return stroke resulting in a very high flow exceeding 1500 L/min on one of the control edges. The benefit of the regenerative function is that it leads fluid from the cylinder outlet back to its inlet assuring a fast stroke at its given pump inlet flow. It is applicable with differential cylinders only during their dead stroke and return stroke at low pressure.

As the flow is too large for spool directional control, 2/2 solenoid controlled DIN slip-in cartridges are used as logic elements combined in the directional function.

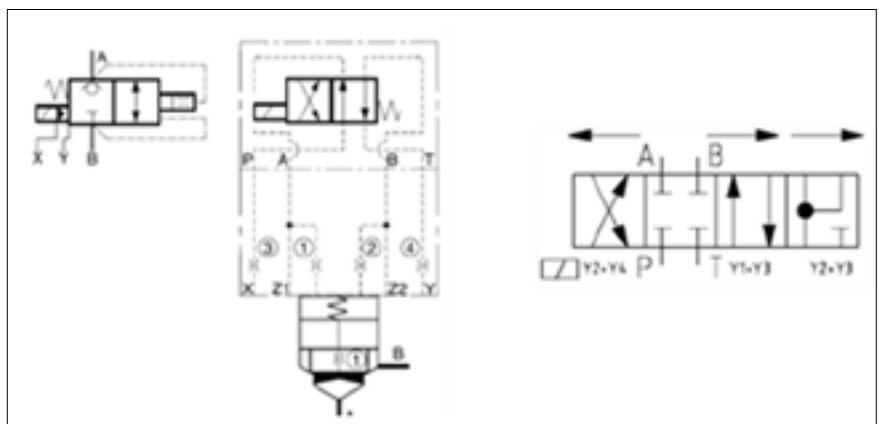

Figure 4. 2/2 DIN slip-in cartridge and simplified symbol of regenerative directional

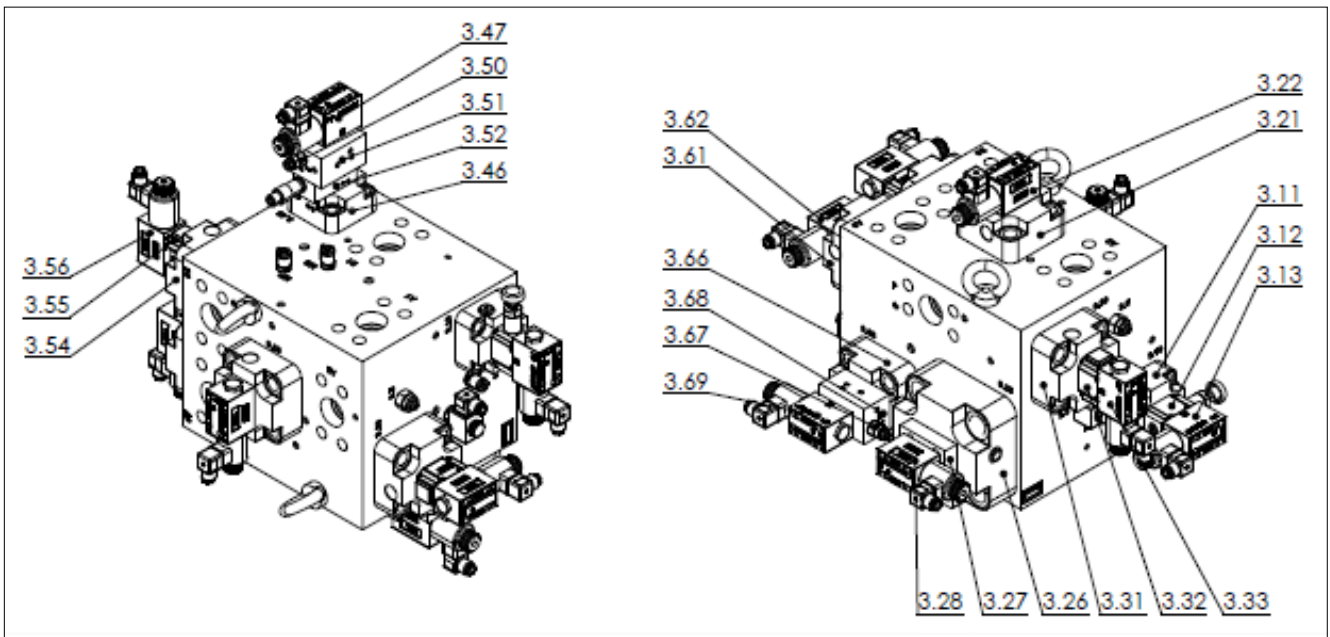

Figure 5. Main manifold design. Pilot valves are located on the surface of the block

Such a solution complicates the design as each port needs its own 2/2 valve but it also offers the possibility to align each valve size exactly to the flow. This is especially important at regenerative circuits where significantly different flows appear on different control edges.

The main hydraulic control block includes eight piloted logic functions in various sizes. While the main function is made of standard 2/2 DIN cartridges in various sizes their pilots are custom designed according to machine requirements.

■ **2.1.1 Counterbalance valve**

To achieve smooth operation of the pre-compression system cylinder it needs to be counterbalanced. Usually ready-available counterbalance valves are used but in our case due to large flow and potential simplification of control circuit, counterbalancing was achieved by specific upgrading of some of the existing DIN slip-in cartridges by adding counterbalance valve to their pilot assembly. This kind of solution was unique and needed careful testing and tuning before its implementation. The risk that the solution would

not prove correct was mitigated by preparing alternative solutions that could be used in case of failure although not being ideal. In-house tests and final commissioning have proven the solution and today, smoothly controlled operation of the pre-compression system is one of the machine's advantages.

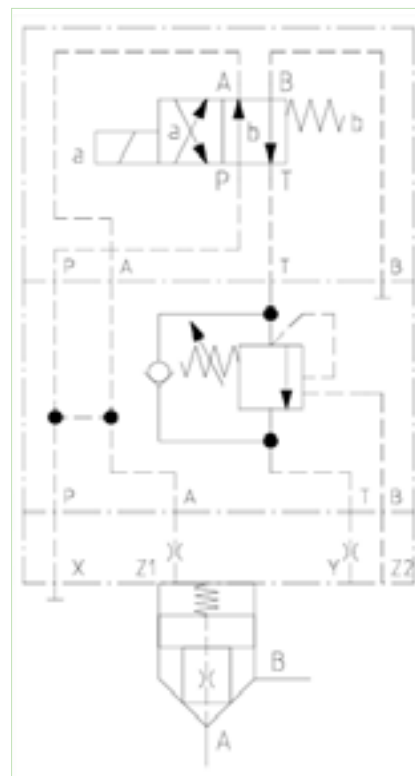

Figure 6. DIN slip-in cartridge piloted by counterbalance valve

■ **2.1.2 Manifold machining, assembly and testing**

The hydraulic manifold was designed using 3D CAD modelling upgraded with a module for hydraulic manifolds design that supports the optimal CAD design in terms of compactness and machining optimization and also assures automatic CAM preparation for CNC machining. Poclairn Hydraulics d.o.o. in Žiri has a strong machining workshop and block machining is one of its core competences.

All hydraulic manifolds are tested before being installed into a system. The purpose of testing is to check for possible product failures as for instance wrong internal connections or integrated valve malfunction, as well as to check if their characteristics fit the project needs. As the function of manifolds can be very complex with size exceeding the available testing flow or power it is very difficult to simulate a real operational environment. Therefore the designer needs to prepare a testing procedure that checks critical performance as close to real operation as possible.

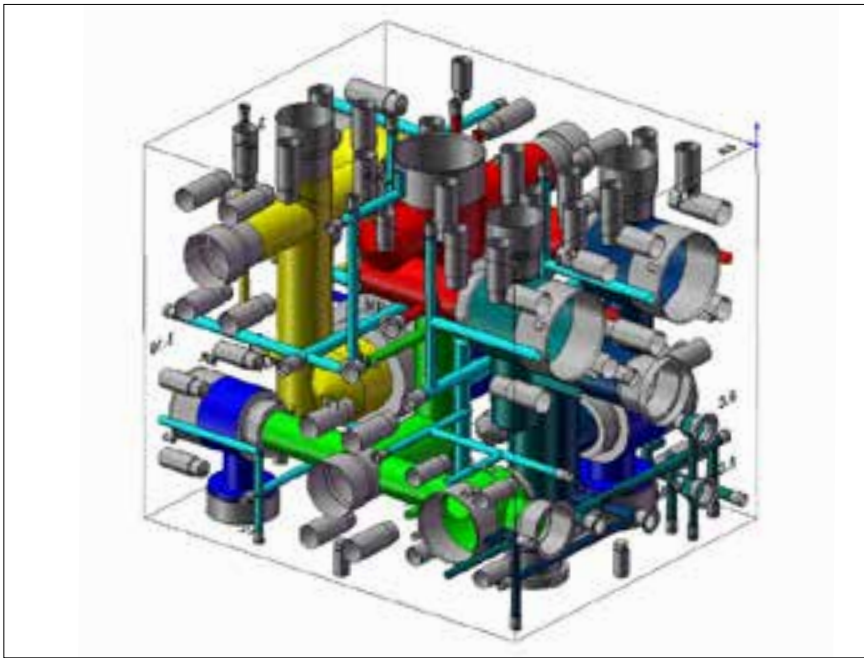

Figure 7. 3D CAD model of machined block

The drawback of variable-displacement pumps is their cost which increases significantly with pump size especially if the flow needed exceeds the range that is frequently used. The solution is that variable displacement is used only in the flow range that needs to be regulated and the remaining flow is assured by a fixed-displacement pump. In our case, switching to high flow is needed for dead stroke and return stroke, which both happen at a lower pressure. Therefore a fixed-displacement pump can be simple and cost efficient.

One of the advantages of proportional flow control is also the possibility to support soft shifting of large cylinders. The main control manifold switches with on-off logic ele-

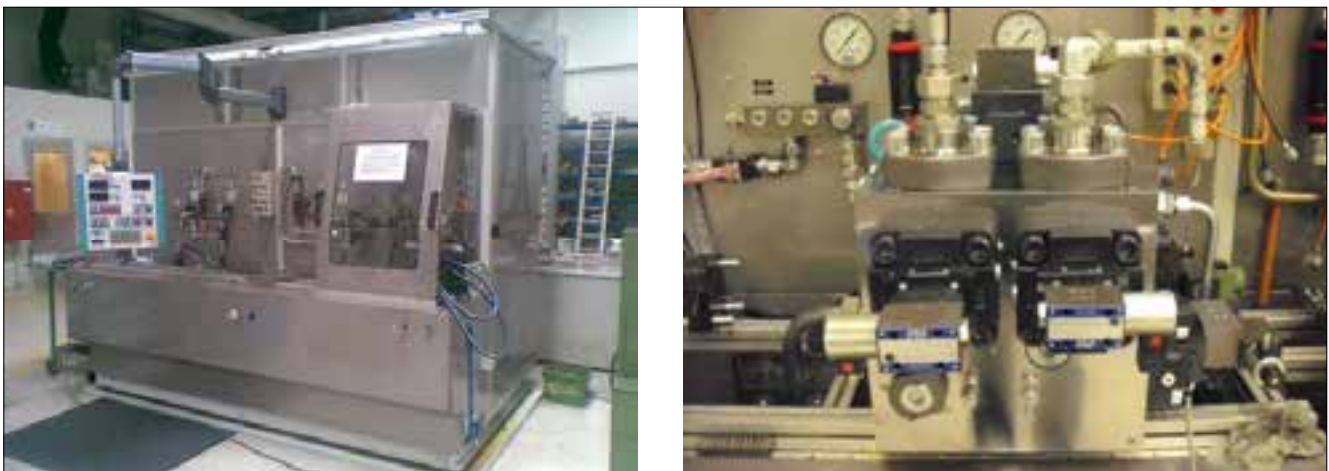

Figure 8. Test bench for manifolds and main hydraulic manifold during testing on test bench

■ 2.2 Pump unit

Assuring a high productivity of the bailer press also means that available energy needs to be efficiently consumed in order to perform a machine cycle that constantly switches between high forces needed to compact the material and high speed needed to make dead stroke and return stroke as fast as possible. Ideally, the combination of pressure and flow at a given moment needs to match exactly the cycle demands. This was achieved using an electronically regulated variable-displacement pump that proportionally sets the position on its p-Q curve following machine electronics.



Figure 9. Variable-displacement pump with electronic p-Q control and additional fixed-displacement pump

ments and this causes immediate blocking of the cylinder movement. At larger speeds and weights high pressure peaks can show up during the switching of movement with a devastating effect on the system's operating life. Some dampening can be achieved with specially shaped poppets, but its effect is limited. With an electronically controlled pump its flow can be decreased anytime in the cycle causing the slowing down of the cylinder. This slow-down can happen right before the switching of the control manifold. Decreased speed of the cylinder means less kinetic energy that has to be absorbed by the system when the control valves stop the load movement.

2.3 Filtration and cooling of hydraulic fluid

Poclain Hydraulics d.o.o. has many years of experience in fluid contamination management. A large part of it comes from projects built for demanding industrial applications. But deeper knowledge was created when fluid cleanliness was studied and monitored on hydraulic test benches in the company's production. This application is very interesting from the fluid cleanliness perspective as the demands for clean fluid are very high but the system suffers from constant pollution ingress from new parts. Proven solutions were then standardized and implemented also on hydraulic power units offered on the market.

Oil cleanliness is crucial for a reliable operation of hydraulic systems especially in applications where the system is heavily loaded in terms of system pressure, switching frequency and duty cycle. Good filtration and humidity removal used in air breathers, tight oil tank cover sealing and effective cylinder scrapper seals are critical to prevent external contamination ingress during operation.

Filtering using in-line or return-line filters was not recognized as optimal for such a bailer-press hydraulic

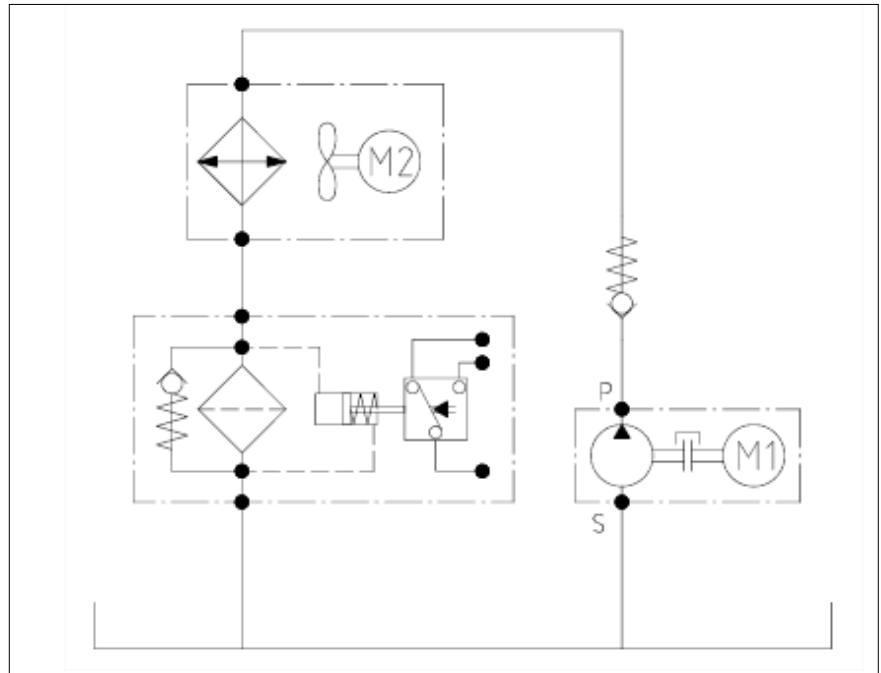

Figure 10. Offline circuit for filtration and cooling

lic system. In-line filters working at high flow and pressure are expensive and together with piping they can take a lot of space. Another problem is the high fluctuation of the flow rate which decreases the filtration effectiveness. This is even more obvious when return-line filters are used in combination with differential cylinders.

Offline filtration with constant fluid flow is used as the main and only filtration of fluid in the system. This means that a separate low-pressure circuit leads fluid through the filter and assures that dirt extraction in the filter is happening at a constant pressure

and flow. The filter has a fine filtration ratio of 5µm and is oversized considering the input flow in order to make sure that also the smallest particles are extracted by sticking on the filter fibres at very low fluid speed.

The offline filtration circuit is combined with an air-oil heat exchanger to maintain the fluid temperature in proper range. Fluid temperature is measured in the oil tank and the cooling fan is switched on and off by machine electronics. In such cases offline flow needs to be designed to optimally fit filtering and heat exchanging needs of the system.



Figure 10. Offline circuit for filtration and cooling

■ 2.4 Hydraulic system testing and commissioning on the machine

After production hydraulic systems are checked if they fit machine requirements.

Testing in the production is mainly focused on possible design and production mistakes, component malfunction and the main parameters of operation. Usually manifolds are the most complex sub-systems and are separately tested before being mounted into the system (see 2.1.2). Finally the complete system is tested and the real working parameters are simulated as much as possible.

Commissioning is done directly on the machine, if possible in its final

working environment. This was also the case in the bailer press project. The machine cycle is monitored by Poclain Hydraulics specialists and adjustments can be done in hydraulics and also electronics to optimize the operation considering the real loads and dynamics of the machine. Frequently such commissioning indicates possibilities for further development of the hydraulic system and respectively improvements of the machine itself.

■ 3 Conclusion

Every hydraulic system is somehow specific and challenges its designers to be innovative and to look for the best possible solutions. The bailer press hydraulic system project described in this article is interesting

as it demands solutions coping with high flow rates and dynamics assuring short machine cycle times. On the other hand it has to be compact, reliable, cost efficient and needs to consider the smallest possible power input. We can say that it shows an example of engineering and production competences that were systematically developed in Poclain Hydraulics d.o.o. and are today critical for the company's competitiveness in this product group.

The project built in close cooperation with the customer – the bailer press builder – is now put in place winning also considerable satisfaction from the final user of the machine and is a nice reference for future business. ■

Hidravlični sistem za večje balirne stiskalnice – načrtovanje, izdelava in prvi zagon

Razširjeni povzetek: V prispevku je predstavljen projekt izvedbe hidravličnega sistema, ki je namenjen za pogon večjih balirnih stiskalnic. Opisane so vse faze projekta, od zasnove in proizvodnje do prvega zagona in testiranja sistema.

Zasnova hidravličnega sistema sledi strogim zahtevam glede produktivnosti in zanesljivosti stroja kot tudi potrebi po kompaktni izvedbi sistema, tudi pri pretočnih količinah, večjih od 1500 L/min. Za doseganje optimalne izrabe razpoložljivih moči so uporabljene posebne rešitve, ki omogočajo doseganje najvišjih možnih hitrosti pogona in sil kot tudi zagotavljanje visoke ravni energetske učinkovitosti.

Zaradi velikih pretočnih količin je hidravlično krmiljenje zasnovano in izvedeno z uporabo logičnih elementov (dvopotnih vgradnih ventilov). Kljub razmeroma zapleteni hidravlični shemi so vse glavne krmilne komponente integrirane zgolj v en večji ventilski blok. Ker hidravlični sistem balirne stiskalnice obratuje v relativno zahtevnem (grobem) okolju, je veliko pozornosti namenjene tudi zagotavljanju ustrezne stopnje čistoče tekočine.

Predstavljeni hidravlični sistem se je kot uspešen in učinkovit izkazal tudi v praksi, kar potrjuje kompetence podjetja Poclain Hydraulics, d. o. o., na področju hidravlične pogonske tehnike in sistemov. To ne velja samo za snovanje hidravličnih sistemov, temveč tudi glede njihove izdelave in praktične uporabe pri namenskih strojih s svojo specifikko.

Ključne besede: balirna stiskalnica, hidravlični sistem, načrtovanje, izvedba, zagon

