

Calculations of the Unloading Operation in Liquid Cargo Service with High Density on Modern Product and Chemical Tankers Equipped with Hydraulic Submerged Cargo Pumps

Andrzej Banaszek^{1,2} - Radovan Petrović³

¹ Technical University of Szczecin, Faculty of Maritime Technology, Poland

² Maritime Academy of Szczecin, Faculty of Economics and Transport Engineering, Poland

³ University of Kragujevac, Faculty of Mechanical Engineering Kraljevo, Serbia

The influence of different liquid cargo density on flow and drive characteristics of hydraulic submerged cargo pumps applied on modern product and chemical tankers is presented in the paper. Main parts of hydraulic structure of a/m system and cargo pump torque controller functions are described. The equation is given for the dependence of discharge rate at service of liquid cargoes (of the same viscosity but different density), based on existing drive and flow characteristics of cargo pumps, prepared for basic cargo.

©2010 Journal of Mechanical Engineering. All rights reserved.

Keywords: hydraulics, submerged cargo pump, flow and drive characteristics, liquid cargo density, product and chemical tankers

0 INTRODUCTION

The cargo loading area of modern product and chemical tankers as ships used for the transport of liquid petroleum-based and chemical cargoes is divided into many separate, smaller cargo tanks. This structure is the result of strong competition on the freight market of liquid cargoes sea transport. However, to an average harbour many different liquid cargoes are usually transported in small quantities. Therefore, on modern product and chemical tankers each cargo tank is equipped with a separate cargo pump. This cargo system concept enables simultaneous transport of many different liquid cargoes in one sea voyage. It also allows the increase of the ship competitiveness on the freight market and its profitability in normal exploitation. A product tanker B573_I/2 type m/t 'Hambisa' built in Szczecin Shipyard SA serves as a good example of such ships. The ship, classified by the International Classification Society - Lloyd's Register (UK), as "Oil and chemical tanker – ship type 2", was designed for the transport of different petroleum based cargoes such as: crude oil, fuel oils, xylene, toluene, lubricating oils, etc. This tanker has the cargo area divided into 20 separate cargo tanks with varied capacity from 1447.1 to 2988.2 m³ and two slop tanks with the capacity 687.2 to 712.1 m³. Every cargo tank is equipped with separate submerged cargo pump,

centrifugal 1-stage type. As they were installed in a dangerous area, their power supply was designed in a hydraulic way, because it is safer than the alternative solution with electric motors. The distances between cargo pumps and other hydraulic receivers mounted on the deck are not too long. Therefore, individual hydraulic feeding systems are in this case, too expensive [1] and [2], and are not applied in the shipbuilding practice [3] and [4]. As a more economical option, the hydraulic central loading system is installed. However, simultaneous drive of several cargo pumps requires the total power up to 3000 kW and more [5] to [7]. Therefore, the hydraulic central loading systems mounted on the boards of modern product and chemical tankers are ranged among the greatest hydraulic systems not only in the ocean technology alone, but in the whole field of hydraulics, as well. The hydraulic system with such high total power enables a great number of hydraulic receivers to be supplied at the same time and independently. A detailed description of how the system works together with technical characteristics and structure, is presented in papers [1], [5] and [6]. There are many factors that influence the discharge flow of the cargo system. The control adjustments of the hydraulic drive are as important as the physical properties of the transported liquid cargoes. In catalogues producers of cargo pumps give only the flow performance characteristics pertaining to the case

*Corr. Author's Address: Technical University of Szczecin, Faculty of Maritime Technology Szczecin, Poland, Al. Piastów 41, andrzej.banaszek@ps.pl

of pumping a standard, basic, liquid cargo, which, typically, is the fresh or sea water. This creates a problem for the designers of cargo installations and fuel terminal and for the tanker's operation crew. In the literature there are not any mathematical algorithms for calculation drive and flow characteristics in the case of real liquid cargoes. The results of research given by the Hydraulic Institute New York, prepared in nomographs form [8] are the most significant. Other authors like Karrasik et al. [9], Lobanoff and Ross [10], Troškolański and Łazarkiewicz [7] and others ([12] to [14]) take advantage of these nomographs. Such an approach is impractical because it demands a manual execution of drive and flow parameters calculations by deck officers and fuel terminal staff supervising the unloading operations of tankers. This situation can lead to errors in the staff service, which can be extremely dangerous in exploitation practice.

In this paper we present the influence of liquid cargo density on the change of flow of cargo pumps and drive characteristics. The resulting change of the flow of the cargo system, in the case of shipment of some different liquid cargoes, is also shown in the paper. The presented computing equation can also be helpful for more effective planning of works in harbour fuel terminals.

1 DENSITY RANGE OF THE STANDARD LIQUID CARGOES IN SEA TRANSPORTATION MARKET

One of the most important technical properties of liquid cargo is its density. Table 1 shows the density of the most common liquid cargoes [15] to [18]. Standard liquid cargoes in sea transport are characterized by a large variability of density. Generally, petroleum based cargoes usually have density below fresh water density level, commonly treated as the basic cargo in maritime area comparisons (from about 667 kg/m^3 for naphtha). However, the majority of chemical liquid cargoes, especially acids, are characterized by much higher density reaching about 2000 kg/m^3 . An example: the density of sulphuric acid (98% liquid at temperature 20°C) reaches 1830 kg/m^3 . Also Strong Sand Dirty Crude Oil has much higher density than water.

Table 1. *Density of standard liquid cargoes on sea transport freight market*

Name of liquid cargo	Density [kg/m^3]	Temperature [$^\circ\text{C}$]	
Crude Oil, Arabian Heavy, Ras Tannura, Saudi Arabia	887	37.8	
Crude Oil, Wilmington, Long Beach, California USA	933	37.8	
Crude Oil, Quiri, Carpito, Venezuela	959	37.8	
SOR Heavy Fuel Oil (HFO)	940	15	
SOR Light Fuel Oil (LFO)	830	15	
Gasoline, Vehicle	710	15.6	
Vegetable Oil (Oliva)	910	25	
Hydraulic Oil	Mobil VI = 146 DTE11M	859	40
	Mobil VI = 141 DTE15M	879	40
Gear Oil, Delvac 1MX2T	Mobil VI = 140 75W90	859	40
	Mobil VI = 139 80W140	870	40
Engine Oil, Vehicle Mobil 1 10W-30 VI = 147	860	40	
Glycerine	1270	20	
Residual Fuel Oil Sorbo110	970	40	
Methanol	790	20	
Toluene	870	20	
Benzene	900	20	
Hydrochloric Acid (Liquid) 30%	1161	20	
Sulphuric Acid (Liquid) 98%	1830	20	

Such wide density range must be taken into account by an engineer designing ship cargo installation and by deck officers who supervise the unloading operation and the suitability of parameter settings of hydraulic drive systems. It may have an important influence on the shipment operation strategy and service time at fuel terminal.

In case of large changes in temperature (i.e. when liquid cargo is heated), for precise calculations of flow, it is necessary to take into account the changes of the liquid cargo density as the function of temperature. For some liquids they are shown in Fig. 1. The mentioned occurrence can be described with the following simplified Eq. [16]:

$$\rho_1 = \rho_0 \cdot \frac{1 + \beta_t \cdot t_0}{1 + \beta_t \cdot t_1} \quad (1)$$

where ρ_1 is liquid cargo density at new temperature t_1 [kg/m^3], ρ_0 is liquid cargo density at basic temperature t_0 [kg/m^3], β_t is coefficient of liquid cargo cubical expansion [-], t_1 is new temperature of liquid cargo [$^{\circ}\text{C}$], t_0 is basic temperature of liquid cargo [$^{\circ}\text{C}$].

Density changes in relation to the temperature are linear. However, the speed of changes is different in relation to the varied kinds of cargoes. The above mentioned density changes for some kinds of liquid cargoes as fresh water, benzene, glycerin, sulphuric acid and ethanol (alcohol) are presented in Fig. 1.

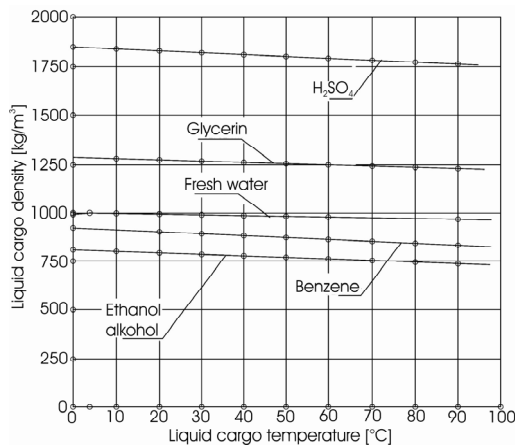

Fig. 1. Density changes of some popular liquid cargoes depending on temperature

2 DESCRIPTION OF HYDRAULIC SUBMERGED CARGO PUMPS USED ON MODERN PRODUCT AND CHEMICAL TANKERS

Cargo pumps used on modern product and chemical tankers are usually of one stage centrifugal type. They are prepared for direct installation inside the cargo tanks. The structure of these pumps with hydraulic drive is shown in Fig. 2. [18]. The main elements of the pumps are: the head of pump, the concentric hydraulic lines with cargo discharge pipe and the deck trunk with a hydraulic control block and connection ports to the cargo deck installation, and other (e.g. hydraulic) service installations. In the head, situated in the lower part of the pump, there is an impeller driven by the hydraulic motor. As a

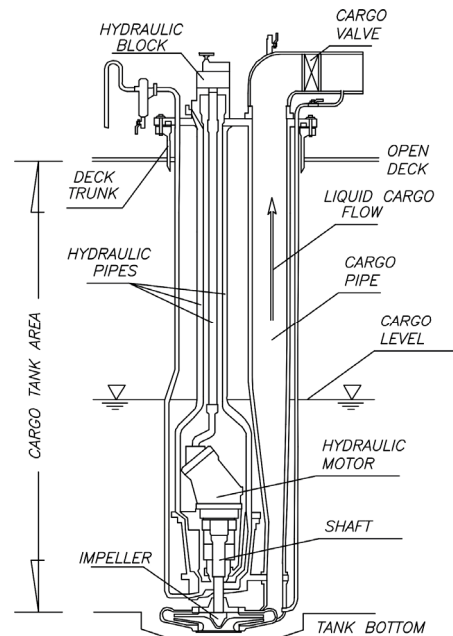

Fig. 2. Typical cargo pump in cargo tank construction

rule, in this type of cargo pumps, the high speed axial piston hydraulic motors of constant displacement are mounted. Usually, due to the required high service reliability and extremely difficult working conditions inside the cargo tanks, there are used motors of A2FM type made by Bosch Rexroth, Germany [20]. The power of standard cargo pumps reaches the level of approx. 200 kW. The hydraulic motor is supplied by means of a concentric pipe system, in which hydraulic oil flows from the control block mounted on the deck trunk. Such a construction, with the hydraulic drive motor localized in the lower part of the cargo pump, makes it possible to avoid an excessive noise and vibrations of the impeller drive shaft by reducing its length to a minimum. Usually, these vibrations in classical long-shaft cargo pumps with electric drive are caused by a bad state of the shaft bearings and an unbalanced long-drive shaft. The liquid cargo, pumped by the impeller, flows through the separate cargo pipe mounted in the pump structure to the deck trunk connection port. At the end of the cargo installation, near the pump, a cargo stop valve is installed. It is used to cut the pump off from the rest of the cargo system in the case of pump damage. A hydraulic motor, usually axial-piston type with

fixed displacement q_s , is directly mounted in the lower part of the cargo pump, in the so-called pump head. In this way the length of impeller drive shaft between the drive motor and the rotor is minimal. The detailed description of the construction of the typical submerged cargo pumps with hydraulic drive, are presented in [1], [5] and [6]. As a lot of cargo pumps and other hydraulic energy receivers are installed in a small area limited by the size of the open deck, the popular way of their supplying is hydraulic central loading system. The construction of common hydraulic power pack of high power, hydraulic main lines running along the deck and consisting of pressure line (P), return (R) and leakage line (L; it does not always appear), enables a more economic and flexible powering. To these main lines all hydraulic receivers are connected in parallel way. On the inlet to the cargo pump connection ports hydraulic controllers constant-torque type are installed and they enable a stabilization of cargo pump discharge rate at variable load. The concept of the constant-torque controlling of the cargo pumps is described in [4], [21] and [22]. The detailed description of the main elements as: central loading installation, main power pack unit, auxiliary pump unit, hydraulic control distributor assembly, and oil heating unit or hydraulic oil storage tanks, is given in [1], [5] and [23].

The way cargo pumps are supplied and controlled has a significant influence on their result flow characteristics. As mentioned above, particular cargo pumps are parallelly connected to the main lines of the hydraulic central loading system. Important parameters of a given cargo pump discharge control are: main power pack unit working pressure p_G adjusted by means of $p = \text{const}$ controller (installed in power pack room) and pressure drop adjustment Δp_s in a constant torque controller of a cargo pump. Only by means of these two parameters can a deck officer managing ship unloading process adjust the discharge rate. The flow and drive characteristics of a typical submerged cargo pump, powered from hydraulic central loading system, is shown in Fig. 3. The shown characteristics are prepared only in relation to fixed properties of the basic cargo. This is usually fresh water, characterized by density equal 1000 kg/m^3 and kinematical viscosity $1 \cdot 10^{-6} \text{ m}^2\text{s}^{-1}$.

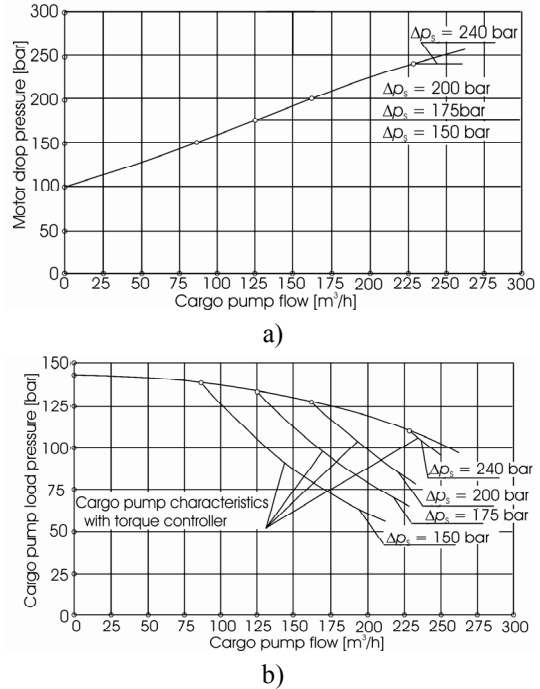

Fig. 3. Typical submerged cargo pump flow and drive characteristics a) Motor pressure drop depending on cargo pump flow b) Cargo pump load pressure depending on cargo pump flow

3 ANALYSIS OF THE PROBLEM

For the analysis of centrifugal pump activity the Euler equation can be used. In accordance with this formulation [24] it can be assumed that torque value M_0 on the drive shaft of cargo pump rotor is proportional to liquid cargo density:

$$M_0 = K_\rho \cdot \rho_C \quad (2)$$

where K_ρ is proportional coefficient [m^5/s^2], ρ_C is liquid cargo density [kg/m^3].

Drive torque value of axial-piston hydraulic motor driving cargo pump impeller, can be determined by means of Schloesser's equation in the following way:

$$M_S = \frac{q_S}{2\pi} \cdot \Delta p_S - C_{mf} \cdot \frac{q_S}{2\pi} \cdot \Delta p_S - C_{m\mu} \cdot n_S \cdot q_S - C_{mh} \cdot \frac{\rho \cdot n_S^2}{4\pi} \cdot \sqrt[3]{q_S^5} - \Delta M_C \quad (3)$$

where M_S is performance torque on motor drive shaft [Nm], q_S is hydraulic motor displacement [m^3], n_S is cargo pump rotation velocity [rpm], ρ

is hydraulic oil density [kg/m³], C_{mf} , $C_{m\mu}$, C_{mh} are proportional coefficients experimentally determined [-], ΔM_C is constant loss torque in hydraulic motor [Nm].

According to Eq. [3] the can be simplified to the following form:

$$M_S = \frac{q_S}{2\pi} \cdot \Delta p_S - \Delta M_S = M_{ST} - \Delta M_S \quad (4)$$

where M_{ST} is theoretical torque on motor drive shaft [Nm], ΔM_S is total loss torque in hydraulic motor [Nm], and next to:

$$M_S \approx M_{ST} = \frac{q_S}{2\pi} \cdot \Delta p_S \quad (5)$$

Thus, comparing these dependencies, Eqs. (2) and (5), it can be assumed that hydraulic pressure drop in the hydraulic motor of a cargo pump is proportional to liquid cargo density:

$$M_0 = M_S, \quad \frac{\Delta p_{SW}}{\Delta p_{SC}} = \frac{\rho_W}{\rho_C} \quad (6)$$

where Δp_{SW} is hydraulic oil drop pressure in pump motor in case of water discharge [bar], Δp_{SC} is hydraulic oil drop pressure in pump motor in case of cargo discharge [bar], Δp_S is hydraulic motor pressure drop [bar], ρ_W is water density [kg/m³], ρ_C is liquid cargo density [kg/m³].

Hydraulic oil pressure drops are presented in Fig. 4, in the process of hydraulic motor supply from central loading system. According to Fig. 4 the hydraulic motor pressure drop Δp_S is:

$$\Delta p_S = p_1 - p_2 \quad (7)$$

where is p_1 inlet pressure to the hydraulic motor []; it is:

$$p_1 = p_G - \Delta p_{RP} - \Delta p_{Z0} - \Delta p_{REG} \quad (8)$$

p_G is working pressure of the main hydraulic power pack unit [], Δp_{RP} is pressure drop in hydraulic main pressure line []:

$$\Delta p_{RP} = \sum_{i=1}^n \lambda_i \cdot \frac{l_i}{d_i} \cdot \rho \cdot \frac{v_i^2}{2} + \sum_{j=1}^m \zeta_j \cdot \rho \cdot \frac{v_j^2}{2};$$

$$v_{i,j} = \frac{4Q_{i,j}}{\pi \cdot d_{i,j}^2} \quad (9)$$

where Δp_{Z0} is pressure drop in ball valve (we can neglect a/m value as small ref. to others $\Delta p_{Z0} \approx 0$), Δp_{REG} is pressure drop in hydraulic constant-torque controller, $d_{i,j}$, $Q_{i,j}$, $v_{i,j}$ are diameter in pipe, oil flow, oil velocity.

Pressure in outlet port of hydraulic motor we can calculate as:

$$p_2 = p_{ZP} + \Delta p_{ZZ} + \Delta p_{RR} \quad (10)$$

where Δp_{RR} pressure drop in hydraulic main return line can be expressed by equation:

$$\Delta p_{RR} = \sum_{i=1}^{n1} \lambda_{i1} \cdot \frac{l_{i1}}{d_{i1}} \cdot \rho \cdot \frac{v_{i1}^2}{2} + \sum_{j=1}^{m1} \zeta_{j1} \cdot \rho \cdot \frac{v_{j1}^2}{2};$$

$$v_{i1,j1} = \frac{4Q_{i1,j1}}{\pi \cdot d_{i1,j1}^2}, \quad (11)$$

where Δp_{ZZ} is pressure drop in non return valve (we can assume that for standard spring valve $\Delta p_{ZZ} \approx 0.5$ bar), p_{ZP} is adjustment pressure in support relief valve in filling up system of the main hydraulic power pack unit; the adjustment of the aforementioned support valve in typical hydraulic central loading systems amounted: $p_{ZP} = 4$ bar.

Constant-torque controller establishing hydraulic oil flow to hydraulic motor works when this relation exists:

$$p_1 - p_2 < \Delta p_{SN} \quad (12)$$

where Δp_{SN} is adjustment in the controller of a nominal hydraulic oil pressure drop in the motor then the controller acts as a flow regulator maintaining the constant flow of hydraulic oil reaching the hydraulic energy receiver.

Dismissing volumetric losses in hydraulic motor, we can assume that the rotation speed of cargo pump rotor is constant, independent from load.

However, when pump load increases to the level of:

$$p_1 - p_2 = \Delta p_{SN} \quad (13)$$

then constant-torque controller will adjust pressure drop in valve Δp_{REG} in the way that pressure drop in hydraulic motor will be constant and equal $\Delta p_S = \Delta p_{SN}$.

The dependence Eq. (6) shows that liquid cargo density has an essential influence on loading torque of cargo pump rotor and on the resulting hydraulic oil pressure drop in hydraulic drive motor. In order to use directly the existing cargo pump flow characteristics prepared for basic cargo (e.g. fresh water) one has to correct appropriately cargo pump drive characteristics, or in other words, to consider the coefficient including the changes in liquid cargo density with reference to basic cargo. Constant torque controller adjustment must also be corrected taking into consideration the aforementioned coefficient where the corrected adjustment will amount to:

$$\Delta p_{SC} = \frac{\rho_C}{\rho_W} \Delta p_{SW} \quad (14)$$

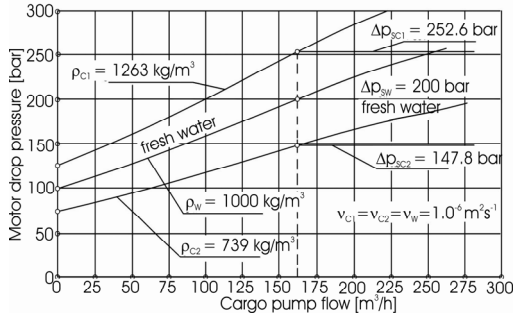

a)

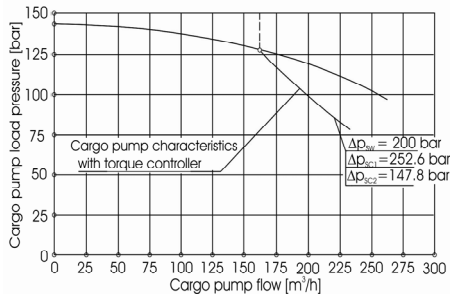

b)

Fig. 5. Influence of cargo density value on the change of cargo pump drive characteristics
a) motor pressure drop depending on pump flow and fluid densit, b) pump load pressure depending on pump flow

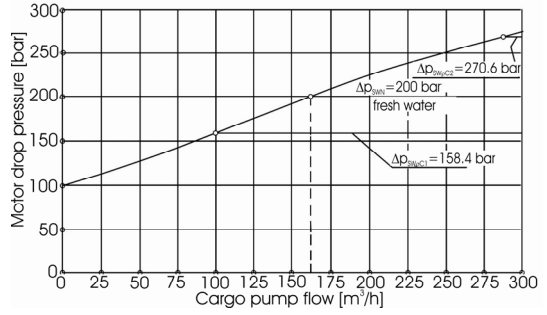

a)

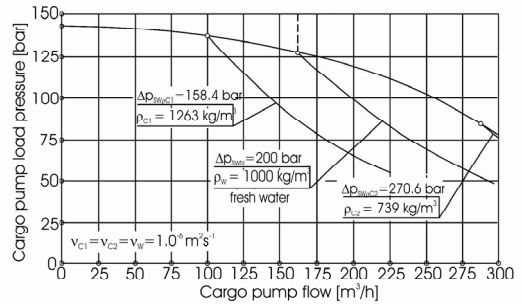

b)

Fig. 6. Influence of cargo density on the change of cargo pump flow characteristics
a) motor pressure drop depending on pump flow of fresh water b) pump load pressure depending on pump flow and density of fluid

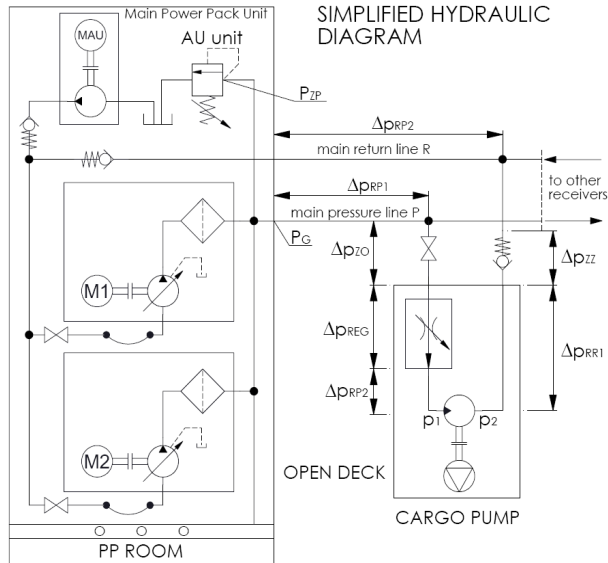

Fig. 4. Oil pressure drops in cargo pump – motor hydraulic installation

With such corrected characteristics of oil pressure drop in hydraulic drive motor, cargo

pump flow characteristics do not change (at the same liquid cargo density - see Fig. 5). However,

we usually deal with the situation in which we must specify cargo pump discharge rate at the service of new liquid cargo with density different from basic cargo density and with same constant torque controller adjustment and power pack working pressure. In this case we have to calculate the replacing oil pressure drop in cargo pump drive motor, reflecting the influence of new liquid cargo density. The drive characteristics in this case will remain the same. Only cargo pump load will undergo a change, i.e. $\Delta p_{SN\rho}$. The replacing pressure drop $\Delta p_{SN\rho}$ must be calculated in accordance with the following equation:

$$\Delta p_{SW\rho} = \frac{\rho_W}{\rho_C} \Delta p_{SWN} \quad (15)$$

The determined replacing value $\Delta p_{SN\rho}$, put into cargo pump drive characteristics, will allow to correct the resulting cargo pump discharge rate and to draw the new corrected flow characteristics (Fig. 6). As seen in Fig. 6, the smaller cargo density, the higher the replacing pressure drop $\Delta p_{SN\rho}$ and, thus, higher cargo pump discharge rate.

4 EXAMPLE OF CARGO PUMP FLOW AND DRIVE CHARACTERISTICS CALCULATIONS IN CASE OF SULPHURIC ACID AS HIGH DENSITY LIQUID CARGOES SERVICE

As an example of a pumping operation of real liquid cargo characterized by high density using submerged cargo pump the analysis of liquid 98% Sulphuric Acid (H_2SO_4) in service was carried out. Theoretical and practical directions for this analysis are given in [25] to [29]. For this operation a submerged cargo pump FRAMO SD125-5 type was used. Nominal speed of cargo pump was 2480 rpm and nominal pressure drop in hydraulic motor was adjusted on the level $\Delta p_{SN} = 240$ bar.

The analysed cargo pump in described conditions enabled the pumping of fresh water as basic cargo with discharge flow up to $Q_{FW0} = 228$ m³/h without the hydraulic torque controller activity (Fig. 7). This means that the load of hydraulic motor to this discharge value was smaller than $\Delta p_{SN} = 240$ bar.

In case of sulphuric acid service, characterized by higher density ($\rho = 1830$ kg/m³, $\nu = 13.9 \cdot 10^{-6}$ m² · s⁻¹), the assistance of torque controller began earlier,

from the value of discharge flow $Q_{H_2SO_4} | n = n_{nom} = 48$ m³/h.

It is the result of a higher load of drive system in case of pumping liquid cargo with such a high density. Influence of higher viscosity of sulphuric acid on the pump flow characteristics in this case was minimal. Reduction of impeller speed to 80% of nominal value did not have any special influence on the pump drive characteristics, still being on higher position in relation to the basic drive characteristic, prepared for fresh water at nominal speed. Analysing this and some other examples the knowledge from following literature was taken into consideration: [12], [13], [18], [23], [26] to [28], [30] and [32].

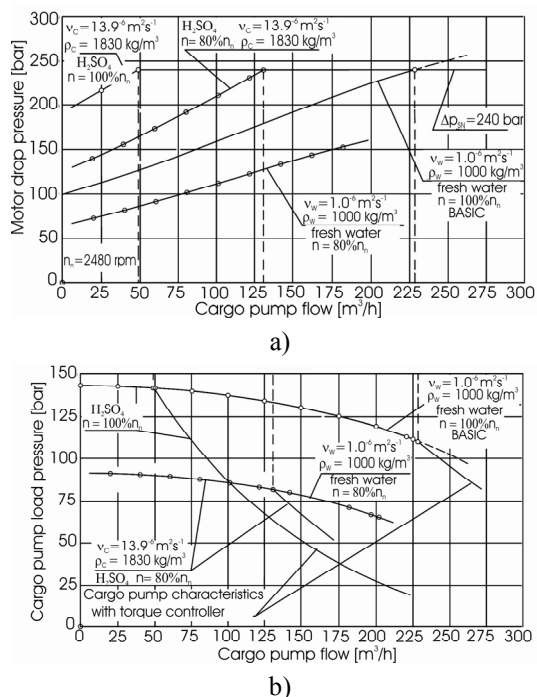

Fig. 7. Flow and drive characteristics of cargo pump FRAMO SD125-5 in case of Liquid sulphuric acid 98%

5 SUMMARY

One of the most important systems mounted on board of modern product and chemical tankers are cargo systems designed for the service of transported liquid cargoes. Submerged cargo pumps are the main parts of these systems. They are usually centrifugal, one stage type, installed directly in cargo tanks in a

dangerous area, respecting the possibility of explosion. Therefore, the described cargo pumps are usually realized with hydraulic drive, supplied from hydraulic central loading system. This powering system is most effective and popular in shipbuilding practice. Tanker's staff supervising the cargo system operation has for disposal only standard cargo pumps drive and flow characteristics, prepared by the pump's producer for basic liquid cargo. Usually, it is fresh or sea water. Such determined characteristics are not valid for other liquid cargoes service characterized with different cargo properties, especially its density. The most important conclusions from executed calculations are as follows:

- Cargo system operator on board of a tanker should take into account the properties of pumped liquid cargoes when planning the unloading operation in fuel terminal.
- Density of the pumped liquid cargo has a significant influence on the higher loading of the cargo pump drive and hydraulic motor characteristics.
- In the case of liquid cargo temperature changes, the cargo system operators on the boards of tankers should include the corrected value of the density depending on liquids temperature in the calculation procedure.

REFERENCES

- [1] Banaszek, A. (2003) Central loading systems on product and chemical tankers (in Polish). *Hydraulika i Pneumatyka* (Hydraulics and Pneumatics) no. 4, p.13-16, ISSN 1505-3954.
- [2] Kollek, W., Palczak, E. (1994) *Elements optimalization of hydraulic systems* (in Polish), Copyright by Zakład Narodowy im. Ossolińskich, Wrocław 1994.
- [3] Banaszek, A. (2006) The influence of liquid cargo viscosity on discharge rate of hydraulic submerged cargo pumps used in transport at sea, *Archives of Transport*, no. 4, p. 25-32.
- [4] Banaszek, A. The concept of capacity control of hydraulic submerged cargo pumps in liquid cargoes transport at sea, *Marine Technology Transactions*, vol. 16, p. 25-32.
- [5] Banaszek, A. (2006) Hydraulic drive of cargo pumps on product and chemical tankers (in Polish), *Przegląd Mechaniczny*, (Mechanical Review) no. 1, p. 37-41, ISSN 0033-2259.
- [6] Banaszek, A. Big power central hydraulic loading systems on board product and chemical tankers, *Proc. 19th International Conference of Hydraulics and Pneumatics*, p. 52-59.
- [7] Troskoleński, A.T. (1973) Łazarkiewicz, S. *Centrifugal pumps* (in Polish), 3th Edition, WNT, Warsaw 1973.
- [8] ANSI/HI *Effects of liquid Viscosity on Rotodynamic (Centrifugal and Vertical) pump performances*. ANSI/HI no 9.6.7, New York 2004, SBN 1-880952-59-9.
- [9] Karassik, J.J., Cooper P., Messina J.P., Heald C.C. (2008) *Pump Handbook*, Ed. 4, Mc Graw-Hill Professional, ISBN 13-978-0-07-146044-6.
- [10] Lobanoff, Val S., Ross R.R. (1992) *Centrifugal Pumps & Applications*, Gulf Professional Publishing, ISBN 0-87201-200-X.
- [11] Neumaier, R. (1994) *Hermetic pumps, The ecological solution of centrifugal pumps and rotary displacement pumps*, Sulzbach Verlag und Bildrchiv, Sulzbach, p. 25-40, ISBN 3-929682-09-5.
- [12] Kraemer, R., Neumaier, R. (1992) *Centrifugal pumps and rotary positive displacement pumps of hermetic design*, Lederle-Hermetic pumps GmbH, Guldenfingen, p. 51-55.
- [13] Jackowski, K., Jankowski, Z., Jędral, W. (1992) *Pump systems* (in Polish), Copyright by Copyright by Wydawnictwo Politechniki Warszawskiej, Warsaw 1992.
- [14] Wiktor, E. (1994) *Ship cargoes – Guide* (in Polish), Polish Cargo Experts Society, Sopot, ISBN 83-902037-1-5.
- [15] Michałowska, J. (1983) *Fuels, Oils, Lubricating Oils* (in Polish), Copyright by Wydawnictwo Ministerstwa Komunikacji i Łączności, Warsaw 1983, ISBN 83-206-0269-6.
- [16] Patir, N., Cheng, H.S. (1979) Application of average flow model to lubrication between rough sliding surfaces. *ASME Trans., J. of Lub. Tech.*, vol. 101.
- [17] Sanchen, G. (2003) *The lecture about swash-plate axial piston pumps with help of numeric simulation*, PhD Thesis, Shaker, RWTH Aachen. (in German)
- [18] Petrović, R. (1999) *Mathematical modeling and identification of multicylindrical axial piston pump parameters*, PhD Thesis, Faculty

- of Mechanical Engineering, Belgrade.
- [19] Plummer, A.R. (2008) A Detailed Dynamic Model of a Six-axis Shaking Table. *Journal of Earthquake Engineering*, vol. 12, no. 4, p. 631-662.
- [20] Plummer, A.R. (2007) Control techniques for structural testing: a review Proc. Instn. Mech. Engrs, Part I, *Journal of Systems and Control Engineering*, vol. 221, no. 2, p. 139-169.
- [21] Plummer, A.R. (2007) High bandwidth motion control for multi-axis servohydraulic mechanisms, *ASME International Mechanical Engineering Congress and Exposition, IMECE2007*, Seattle, USA.
- [22] Jędral, W. (2001) *Centrifugal pumps* (in Polish), PWN, Warsaw 2001, ISBN 83-01-13552-2.
- [23] Čantrak, S., Glavčić, Z., Petrović, R. (2002) Modelling of transition process behind the local resistance depending on flow rate circumference component, *Third International Conference Heavy Machinery – HM '02*, p. E17-E20.
- [24] Petrović, R. (2009) Mathematical Modeling and Experimental Verification of Operating Parameters of Vane Pump With Double Effect, *Journal of Mechanical Engineering - Strojniški vestnik*, vol. 55, no. 1, p. 26-32.
- [25] Enekes, C., Murrenhoff, H. (2007), Verwendung beschichteter Bauteile im tribologischen System Kolben-Buchse in Axialkolbenmaschinen, 48. *Tribologie-Fachtagung 2007*, Goettingen, vol. 2, no. 41, p. 1-11.
- [26] Ivantysyn, J., Ivantysynova, M. (2001) *Hydrostatic Pumps and Motors. Principles, Design, Performance, Modelling, Analysis, Control and Testing*, First English Edition, Akademia Books International New Delhi.
- [27] Renius, K.T. (1974) *Research of the friction between piston and cylinder in swash-plate type axial piston machines*, VDI-Verlag Düsseldorf. (in German)
- [28] Kollek W., Palczak E. (1994) *Elements optimization of hydraulic systems* (in Polish), Copyright by Zakład Narodowy im. Ossolińskich, Wrocław 1994.
- [29] Kleist, A. (2002) *Calculations of the tightness and gaps in bearings in hydrostatic machines*, PhD Thesis, Shaker, RWTH Aachen. (in German)
- [30] Plummer, A.R. Closed-loop velocity control for an electrohydraulic impact test system, *PTMC 2005 Bath*, p. 75-90.