

Kogeneracija v sodobnih sistemih za ogrevanje, prezračevanje in klimatizacijo

Cogeneration in Modern Systems for Heating, Ventilation, Air-Conditioning and Cooling (HVAC)

Petar Donjerković - Hrvoje Petrić

Sodobni razvoj majhnih kogeneracijskih obratov v zahodnih deželah kaže, da energija in okolju prijazna rešitev nista samo zaželeni, ampak tudi gospodarni. Kogeneracijske izvedbe velikih, srednjih in celo dandanes majhnih ogrevalnih, prezračevalnih in klimatiziranih obratov (OPK - HVAC), postajajo običaj v modernih sistemih.

Prispevek se ukvarja z osnovami kogeneracijskih OPK sistemov, z upoštevanjem batnih strojev v kombinaciji s prenosniki toplote in absorpcijskimi hladilnimi napravami. Opisan sistem je analiziran z vidika osnovne energijske, ekološke in gospodarstvene povezanosti. Predstavljena je tudi pred kratkim popularna mikro kogeneracija za majhen OPK sistem.

Konstrukcija kogeneracijskih OPK sistemov je pogosto povezana s delnimi problemi ali celo ovirami, ko se primerja z instalacijo običajnega sistema, predstavljeni so tudi nekateri glavni problemi.

Končno so teoretična spoznanja kogeneracijskih OPK sistemov vključena v primer, odkrit v bolnišnici na Hrvaškem. Omenjen sistem v resnici prikazuje glavne tehnične in gospodarstvene značilnosti tega sistema.

Na koncu predstavlja prispevek vodila za sodobni razvoj upravljanja z energijo kot funkcijo moči, ogrevanja in proizvodnje hladilne energije. Razloži, da kogeneracijski OPK sistemi niso primerni samo s tehničnega vidika, ampak tudi z gospodarskega.

© 2000 Strojniški vestnik. Vse pravice pridržane.

(Ključne besede: kogeneracija, sistemi HVAC, gospodarjenje energetsko, analize sistemov)

Present trends in Western countries suggest that small cogeneration plants are preferable not only in terms of energy and the environment but also from the economic perspective. The application of cogeneration in large, medium and nowadays even small heating, ventilation and air-conditioning (HVAC) plants, is becoming common in modern systems.

This paper deals with the basics of cogeneration-HVAC systems, considering reciprocating engines in conjunction with heat exchangers and absorption chillers. The described system is analyzed from the point of view of key energy, ecology and economy correlations. Moreover, an introduction to the recently popular micro-cogeneration for a small HVAC system is given.

Since the construction of cogeneration-HVAC systems can often be linked with practical problems or even barriers, particularly when compared with the installation of a conventional system, some of these major problems are also described.

Finally, these theoretical considerations of cogeneration-HVAC systems are integrated with an example from a hospital in Croatia. This example illustrates the main technical and economic characteristics of such a system on a real site.

As a conclusion, the paper introduces guidelines to modern energy-management trends as a function of power, heating and cooling energy production. It explains that cogeneration-HVAC systems are viable not only from the technical point of view, but also from the economic one.

© 2000 Journal of Mechanical Engineering. All rights reserved.

(Keywords: cogeneration, HVAC systems, energy management, system analysis)

0 UVOD

Sodobni razvoj v Zahodnih deželah kaže, da je smotna uporaba energije z njenimi gospodarskimi in ekološkimi zahtevami osnovna predpostavka vzdržljivega razvoja. Izvedbe različnih modernih tehnologij za

0 INTRODUCTION

Present trends in Western countries show that the rational use of energy, with its economic and ecological hypothesis, is the basic requirement for sustainable development. The application of

pridobivanje energije in predelave pogosto vključuje povečanje investicijskih stroškov, toda njihova gospodarstvena zmožnost in okoliška upravičenost, v primerjavi z drugimi procesi energijske proizvodnje, postanejo očitna šele po zadostni časovni uporabi obrata. Glede na razvoj se kot ena od rešitev pri gospodarjenju z energijo pogosto uporabijo kogeneracijski sistemi.

Kogeneracija je definirana kot logična uporaba primarne energije za pridobivanje dveh uporabnih energijskih oblik: toplotne energije in moči. Omenjen energijsko spreminjevalni postopek je zanimiv, ker je bistveno odvisen od izstopne oblike energije, stanja izkoriščenosti, velikine obrata in lastništva. Za pojasnilo, proizvodno uporabna moč energije se lahko uporabi za generiranje elektrike ali moči, medtem ko se lahko toplotna energija uporabi pri tehnoloških procesih, ogrevalnih procesih ali hladilnih procesih. Pridobljena energija, toplotna in delno električna, se lahko uporabi na kraju samem, ali razdeli drugim porabnikom. Velikost kogeneracijskega sistema se lahko spremeni od zelo majhnih obratov s kapaciteto od nekaj kilovatov (kW) do večjih enot z nekaj sto megavatov (MW). Koristno je lahko biti lastnik takšnega obrata, uporabnik končne energije ali samostojni pridobivalec energije.

Kogeneracijski sistemi so pogosto upoštevani zaradi svojega velikega energijskega izkoristka in v povezavi s tem zmanjšane zračne onesnaženosti, ki potuje skozi sistem, koristi ekološko in ekonomsko. Glede na dejstvo, da lahko celotni izkoristek teh obratov doseže 90 odstotkov, je očitno, da so današnji kogeneracijski sistemi najučinkovitejši in so tako ekološko ustrezna rešitev za proizvodnjo toplote in moči. Slika 1 prikazuje shematski diagram običajnega kogeneracijskega sistema s prikazano predpostavko o celotni učinkovitosti okoli 85 odstotkov [1].

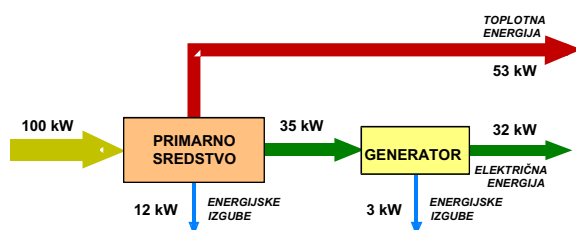

Sl. 1. Shema energijske predelave v kogeneracijskem sistemu

1 KOGENERACIJA OPK SISTEMOV

1.1 Kogeneracijska enota

Prednosti kogeneracijske proizvodnje energije skupaj z nedavnim tržnim razvojem, delno pri tistih s trgom elektrike, je povzročilo, da se kogeneracijski sistemi pogosto uporabljajo kakor prej v ogrevalnih, prezračevalnih in klimatizacijskih

various modern technologies for energy production and transformation requires investment, but the economic viability and the environmental benefits are clear after a period of the plant's use. In view of these trends, one of the solutions in energy management, cogeneration systems, are very often used.

Cogeneration is defined as the sequential use of primary energy to produce two useful energy forms: thermal energy and power. This energy-transformation process is interesting because it is essentially independent of the output-energy form, disposition of its utilization, plant size and ownership. As an explanation, useful power the produced can be used either to generate electricity or shaft power, while the thermal energy could be used in technological processes, heating processes or cooling processes. The energy produced, thermal and in particular electrical, can either be used at the site or distributed to other consumers. The size of a cogeneration system can vary from very small plants with a capacity of only a few kilowatts to large units with several hundred megawatts. Finally, the owner of such plants can be a utility, energy end-user or an independent power producer.

Cogeneration systems are most frequently considered because of their high energy efficiency combined with a reduction in the emission of air pollutants. As the overall efficiency of these plants can exceed 90 percent, it is clear that cogeneration systems are currently the most effective and therefore ecological solutions for heat and power production. Figure 1 shows a schematic diagram of a typical cogeneration system with an overall efficiency of about 85 percent [1].

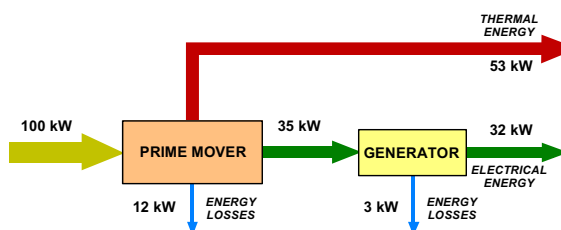

Fig. 1. Scheme of the energy conversion in a cogeneration system

1 COGENERATION HVAC SYSTEMS

1.1 The cogeneration unit

The advantages of cogeneration energy production, together with the recent market deregulation trends, particularly those of the electricity market, mean that cogeneration systems are increasingly being used in heating, ventilation

sistemih (OPK). Kogeneracijske sisteme poznamo kot velike sisteme s toplotno zmogljivostjo deset in več megavatov (MW), srednje z nekaj sto kilovati (kW) do majhnih sistemov z nekaj deset kW. Na tržišču je nekaj znanih proizvajalcev, ki ponujajo kogeneracijske sisteme kot paketne enote, ki se prilagodijo na energijski sistem objekta.

Običajno si lahko kogeneracijske enote zamislimo z različnimi primarnimi sredstvi, zadnje čase pa najbolj splošno uporabljive, tržno razpoložljive kogeneracije vsebujejo batne stroje z notranjim zgorevanjem, zgorevalne turbine ali parne turbine. Druge tehnologije npr. batni parni stroj, Stirlingov motor ali bencinske celice, se manj uporabljajo ali se še zmeraj v preskušajo in niso tržno uporabljive.

Upoštevač kogeneracijske enote v OPK sistemih lahko potrdimo, da se običajno uporabljajo batni stroji z notranjim zgorevanjem. Dokazano je, da so omenjeni stroji cenovno uspešni pri kogeneracijskih izvedbah in z velikim izkustvenim znanjem pri različnih izvedbah in v različnih obratovalnih razmerah. Batni stroji imajo visoko učinkovitost (do 50 odstotkov), celo v manjših velikostih, z dobro storitvijo pri polovični obremenitvi, kratkim zagonom do polne obremenitve in s primerno majhnim vgradnim prostorom. Poleg tega so razpoložljivi v velikem številu različnih velikosti, v nizu od deset kW do nekaj megavatov (MW). S tipično razpoložljivostjo od 7600 do 8400 ur na leto, so najbolj primerni pri izvedbah do dveh ali treh megavatov (MW) [2].

Glede na termodinamični proces in gorivo, se batni stroji delijo v dve osnovni skupini: bencinske in dizelske motorje. Bencinski motorji so znani kot plinski motorji, ki delujejo popolnoma na plin (naravni plin, LPG, bioplin, zemeljski plin itn.), medtem ko dizelski motorji uporabljajo tekoče gorivo ali dvojno mešanico goriva (mešanica naravnega plina z majhnim deležem tekočega goriva). Za majhne zmogljivosti se ponavadi uporabljajo spontani sesalni motorji, medtem ko se za največje moči uporabljajo stroji z dodatnim polnjenjem.

Omenjeni stroji lahko dajejo toplotno energijo v obliki vroče ali vrele vode do 120 °C, in/ali pare nizkega tlaka (do 5 bar) z uporabo odpadne toplote izpušnih plinov (približno 1/3 koristne toplote) v plinskem prenosniku in hladilni vodi (približno 2/3 koristne toplote). Horizontalni ali vertikalni oklepni in cevni prenosniki toplote (voda – voda, voda – mazno olje in voda – para) se uporabljajo za pridobivanje odpadne toplote. Parni generatorji (PG) za pridobivanje toplote vsebujejo tudi cevne prenosnike toplote, ki se uporabljajo za prenos odpadne toplote izpušnih plinov v paro in/ali vodo. Slika 2 prikazuje načelno shemo kogeneracije z uporabo sesalnega in dodatno polnjenega batnega stroja, strnjen s poenostavljenim energijskim pregledom.

and air-conditioning systems (HVAC). Cogeneration systems range from large systems with a heat capacity of ten or more megawatts, to medium-size units with a few hundred kilowatts, to small systems with a few tens of kilowatts. There are a large number of well-known producers in the market that offer cogeneration systems as packaged units which are tailored to the building energy systems.

Cogeneration units can make use of various prime movers, but recently the most commonly employed commercially available cogenerations include internal combustion reciprocating engines, combustion turbines or steam turbines. Other technologies, like reciprocating steam engines, Stirling engines or fuel cells are less frequently used or remain in the demonstration stage and not in commercial operation.

For cogeneration units in HVAC systems internal combustion reciprocating engines are usually used. These engines have proven to be cost effective in cogeneration applications, and there is considerable operational experience for very different applications and under different operating conditions. Reciprocating engines are characterized by high efficiency (up to 50 percent), even for the smaller sizes, good performance at partial loads, short startup to full load and a comparatively small installation space. They are available in a large wide range of different sizes, ranging from tens of kilowatts to a few megawatts. With typical availabilities of 7600 to 8400 hours per year, they are most suitable for applications requiring up to two or three megawatts [2].

With respect to the thermodynamic cycle and the fuel, reciprocating engines fall into two basic groups: Otto engines and Diesel engines. Otto engines are often known as gas engines since they regularly operate on gas (natural gas, LPG, biogas, landfill gas, etc.), while Diesel engines use liquid fuel or a dual fuel mix (mixture of natural gas with a small portion of liquid fuel). For the smaller capacities they are usually naturally aspirated (atmospheric) engines, while the biggest sizes are supercharged or turbocharged engines.

These engines can produce thermal power in the form of hot or warm water up to 120°C, and/or low pressure steam (up to 5 bar) using the rejected heat of the exhaust gases (about 1/3 of the available heat) in the gas exchanger and cooling water (about 2/3 of the available heat). The horizontal or vertical shell and tube heat exchangers (water-water, water-lube oil and water-steam) are used for waste-heat recovery. The heat-recovery steam generators (HRSGs) also include tube heat exchangers used for the transmission of the rejected heat of exhaust gases to steam and/or water. Figure 2 shows the principle of cogeneration using atmospheric and turbocharged reciprocating engines, integrated with a simplified energy balance.

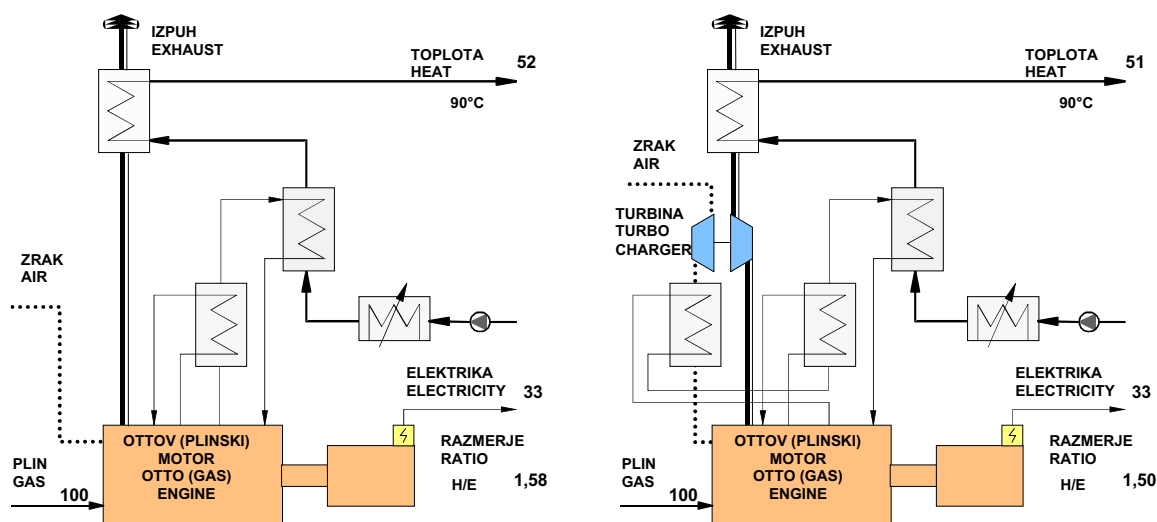

Sl. 2. Kogeneracijska enota s sesalnim in dodatno polnjenim batnim strojem
 Fig. 2. Cogeneration unit with atmospheric and turbocharged reciprocating engine

Visok celotni energijski izkoristek teh sistemov je lahko zapisan (med 78 in 88 %, glede na razpored) in izgube so zaradi izgub v dimniku (8 do 10 %, plini okoli 120 °C), sevanja iz stroja (3 do 5 %) in izgube zaradi trenja na gredi stroja – generatorja (1 do 2 %) [3].

1.2 Absorpcijske hladilne naprave

Ključni parameter za kogeneracijski izbor je podan s toplotno in energijsko porabo, ker je kogeneracija najučinkovitejša, ko pokriva osnovne obremenitve. Pomembno je, da so osnovne toplotne in energijske obremenitve pomemben delež v celotni letni energijski porabi in bi morale omenjene obremenitve trajati več ko 3000 do 6000 ur na leto, nakar kogeneracija postane sprejemljiva. Zato je namen, da s kogeneracijo zagotovimo hladilno energijo v OPK sistemu. Proizvodnja hladilne energije v kogeneracijskih sistemih je zasnovana na izvedbah absorpcijskih hladilnih naprav, ki uporabljajo toplotno energijo iz sistema.

Proizvodnja hladilne energije v kogeneracijskih sistemih je najpogosteje utemeljena na izvedbah absorpcijskih hladilnih naprav, ki uporabljajo toplotno energijo iz sistema, obstajajo celo raztopine, pri katerih uporabljajo mehanske stiskalne naprave. Odkar je prva različica običajna, je kratek pregled tehnologije opisan v nadaljevanju.

Slika 3 prikazuje preprost shematski diagram in primerjavo absorpcijskih in kompresijskih hladilnih krogov. Nekateri avtorji so v absorpcijskem krogu označili s črtkano črto termični kompresor, da bi prikazali podobnost z mehaničnim kompresorjem v kompresorskem krogu [4].

Razlika med absorpcijskim in kompresijskim krogom leži v obliki krožnega nastajanja visokega tlaka pare (VT) od sedanjega nizkega tlaka (NT).

These systems have a high overall energy efficiency between 78 and 88% (according to the arrangement). Losses occur in the stack (8 to 10%, gases at around 120°C), radiation from the engine (3 to 5%) and losses resulting from friction in the engine-generator shaft (1 to 2%) [3].

1.2 Absorption chiller

The key parameter for cogeneration selection is the characteristics of the heat and power consumption as cogeneration is most effective when covering basic loads. It is important that basic heat and power loads represent a significant part of the total annual energy consumption and that these basic loads should exist for more than 3000 to 6000 hours per year since at this point cogeneration becomes viable. Therefore, the intention is to ensure cooling energy in the HVAC system by cogeneration.

The production of cooling energy in cogeneration systems is most frequently based on the application of absorption chillers that use thermal energy from the system, even when mechanical compression devices are used, solutions also exist. Since the first variant is common, a brief overview of this technology is provided.

Figure 3 shows a simple schematic diagram and comparison of the absorption and compression cooling cycles. Some authors refer to the part of the cycle marked by dotted lines as the “thermal compressor” in order to point out the similarity with the mechanical compressor in a compression cycle [4].

The difference between the absorption and the compression cycle lies in the form of the cyclical generation of high-pressure (HP) steam from the present lowpressure (LP). The mechanical

Mehanski kompresorji omogočajo neposredno stiskanje pare, medtem ko je termično stiskanje sestavljeno iz treh stopenj:

- (1) sprememba pare NT v kapljevino VT;
- (2) sprememba kapljevine NT v kapljevino VT;
- (3) sprememba kapljevine VT v paro VT.

compressor makes direct steam compression possible, while thermal compression consists of three stages:

- (1) transformation of LP steam to LP liquid;
- (2) transformation of LP liquid to HP liquid;
- (3) transformation of HP liquid to HP steam.

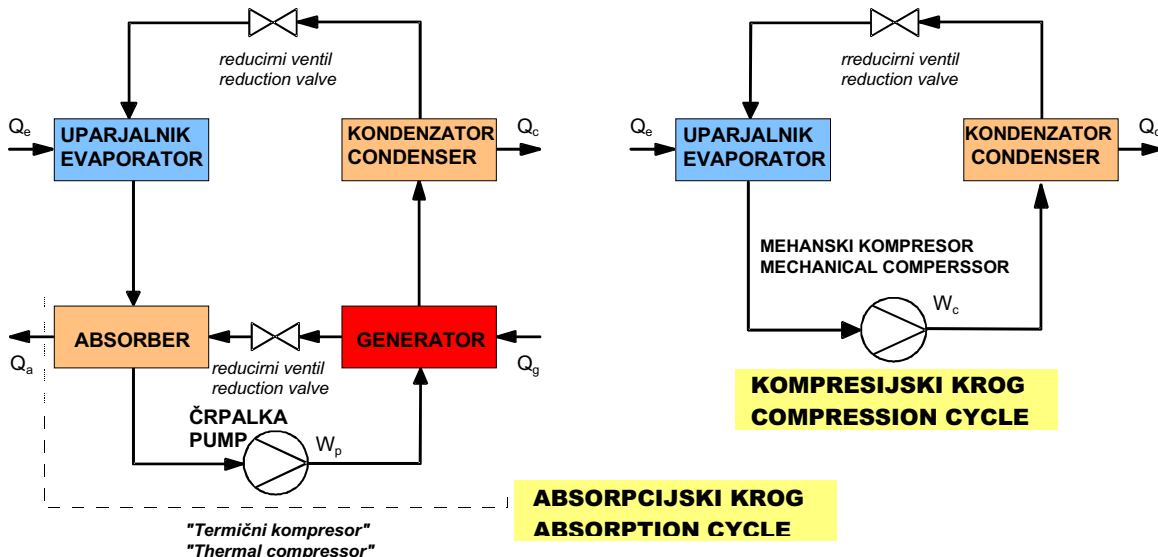

Sl. 3. Primerjava med absorpcijskimi in kompresijskimi krogi
Fig. 3. Comparison between absorption and compression cycles

Druga in tretja stopnja sta izvedeni s preprosto črpalko in generatorjem (vrelnik), medtem ko je prva stopnja izvedena v absorberju, ki daje ime procesu. V absorberju se mrzla para NT, ki prihaja iz uparjalnika, absorbira v revno raztopino, vrnjeno iz generatorja zaradi nizke temperature pare. Črpalka ustvari bogato raztopino (tekočino) pri tlaku generatorja, kjer se ponovno uparja.

Energijska bilanca absorpcijskega kroga je prikazana z naslednjo enačbo:

$$Q_g + Q_e + W_p = Q_c + Q_a \quad (1)$$

Pomen simbolov: Q_g - toplota, ki vstopa v generator, Q_e - toplota, ki vstopa v uparjalnik, W_p - energija, ki jo porabi črpalka (zanemarljivo), Q_c - izločena toplota iz kondenzatorja in Q_a - izločena toplota iz absorberja.

Teoretični absorpcijski krog z idealnim hladivom in absorberjem ter konstantno latentno toploto, je odvisen od tlaka P in temperature T , ta bi imel vrednost $H\dot{S}^1$ blizu 1. V praksi, komercialne naprave delujejo z vrednostjo $H\dot{S}$ okoli 0,6 do 0,7 [5].

Najboljša storitev v omenjenem krogu je dosežena z uporabo toplote, pridobljene v kondenzatorju z dodatno ločitvijo hladiva v

The second and the third stages are carried out by a simple pump and a generator (boiler), while the first stage is performed in an absorber which gives the process its name. In the absorber the cold LP steam that comes from the evaporator is absorbed into the poor solution returned from the generator due to the lower steam temperature. The created rich solution (liquid) is pressed by the pump at the generator pressure level where it evaporates again.

The energy balance of the absorption cycle is shown by the following equation:

Where: Q_g is the heat entering the generator, Q_e is the heat entering the evaporator, W_p is the energy consumed by the pump (neglected), Q_c is the heat extracted from the condenser and Q_a is the heat extracted from the absorber.

The theoretical absorption cycle, with ideal absorbent and refrigerant and a constant latent heat independent of P and T , would have a COP^1 value close to 1. In practice, commercial equipment operates with a COP value of about 0.6 to 0.7 [5].

The best performance in this cycle is achieved by using the heat obtained in the condenser for the additional separation of the refrigerant into

¹ $H\dot{S}$ - Hladilno število: Razmerje med energijo (hladno ali toplo), generirano s ciklom (kompresija ali absorpcija), glede na uporabljeno energijo v kompresorju ali generatorju.

¹ COP - Coefficient of Performance: The relation between the energy (cold or heat) generated by the cycle (compression or absorption) with respect to energy applied to it in the compressor or generator.

kondenzatorju (nizko temperaturni generator). V podobnem dvostopenjskem absorpcijskem krogu z enako vstopno toploto, se tok hladiva v uparjalniku poveča in v teoretičnem primeru je vrednost $H\dot{S}$ skoraj 2. V praksi delujejo tržne dvostopenjske absorpcijske hladilne naprave z vrednostjo $H\dot{S}$ med 1,3 in 1,3 [5].

Absorpcijske hladilne naprave uporabljajo hladivo/absorbent v dvojici bodisi amonijak/vodo (NH_3/H_2O) ali vodo/litijev-bromid ($H_2O/LiBr$) raztopino, s skoraj enakim termodinamičnim izkoristkom, ki je odvisen od zmogljivosti in delovnih temperaturnih razmer. Najnižje hladilne temperature, ki se lahko dosežejo z absorpcijskimi hladilnimi napravami, so v območju od $+4\text{ }^{\circ}\text{C}$ do $+6\text{ }^{\circ}\text{C}$. Zaradi delovanja kot vstopno sredstvo, enostopenjski sistemi potrebujejo bodisi vročo/toplo vodo (90 do $110\text{ }^{\circ}\text{C}$) ali nizkotlačno paro, medtem ko dvostopenjske enote uporabljajo paro višjega tlaka. Glede na zapisano se enostopenjske absorpcijske hladilne naprave običajno uporabljajo v manjših in srednjih kogeneracijskih OPK sistemih, medtem ko večje enote s proizvodnjo pare uporabljajo dvostopenjske enote. Slika 4 prikazuje shemo kogeneracijskega obrata z absorpcijsko hladilno napravo kot del OPK sistema. Ker opisan sistem pridobiva tri različne oblike energije, in sicer moč, toploto in hladilno energijo, je običajno identificiran kot trigeneracijski sistem.

condenser (low-temperature generator). In such a two-stage absorption cycle, with the same input heat, the flow of refrigerant in the evaporator is increased, and for the theoretical case the COP value is almost 2. In practice, commercial two-stage absorption chillers operate with a COP value between 1.2 and 1.3 [5].

Absorption chillers use either ammonia/water (NH_3/H_2O) or water/lithium-bromide ($H_2O/LiBr$) solutions as the refrigerant/absorbant pair with an almost equal thermodynamic efficiency, the choice depending on the capacity and operating temperature. The lowest cooling temperatures that can be reached with absorption chillers are in the range from $+4$ to $+6\text{ }^{\circ}\text{C}$. For the input medium, single-stage systems require either hot/warm water (90 to $110\text{ }^{\circ}\text{C}$) or low-pressure steam, while two-stage units use higher pressure steam. As a consequence single-stage absorption chillers are commonly used in small and medium-size cogeneration-HVAC systems, while larger units with steam production use two-stage units. Figure 4 shows a scheme for a cogeneration plant with an absorption chiller as a part of the HVAC system. Since a system like this produces three different forms of energy, that is power, heat and cooling energy, it is usually recognized as a trigeneration system.

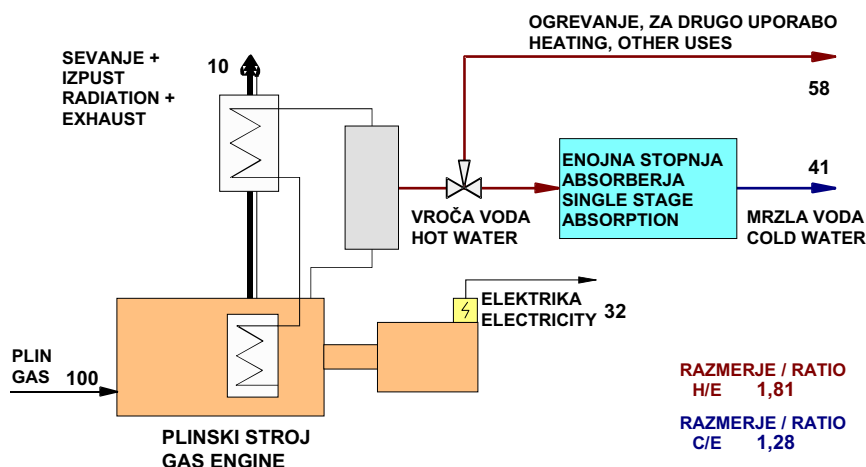

Sl. 4. Trigeneracijska shema za OPK sistem
Fig. 4. Scheme of trigeneration for HVAC system

1.3 Mikro-kogeneracija

Zgoraj opisani kogeneracijski sistemi se uporabljajo dandanes v srednjih in velikih OPK sistemih, kar pomeni, da običajno delujejo z najmanjšo razpoložljivo termično kapaciteto približno 100 kW_t s 50 kW_e moči. Manjši sistemi od teh, ki bi se lahko uporabili v družinskih hišah ali nekaj podobnega, še vedno niso v tržni rabi.

Vseeno mora biti omenjeno, da so nedavno napredovanje in usmeritve energijskega tržišča v

1.3 Micro-cogeneration

The above-described cogeneration systems are currently used in medium and large HVAC systems, which means they usually operate with the smallest available thermal capacity of about 110 kW_t with 50 kW_e of power. Smaller systems than these, which could be used in family houses, are not yet in commercial production.

Recent progress and the deregulation of energy markets in Europe are motivating the

Evropi spodbudile razvoj mikrokogeneracije, ki je namenjena za družinsko uporabo, zagotavljajoč termični izstop od 10 do 25 kW_t in električni izstop, manjši odt 10 kW_e. Podobne mikrokogeneracije temeljijo na Stirlingovem motorju, bencinskih celicah ali majhnih plinskih motorjih. Kot gorivo uporabljajo naravni plin ali utekočinjene naftne pline in celotni primarni energijski izkoristek do 95 odstotkov z majhno NO_x, CO in ogljikovodikovo oddajo. Primerjava z običajnimi plinsko centralno ogrevanimi kotli za gospodinjstve objekte, kjer se 80 do 90 odstotkov primarne energije (naravni plin) preoblikuje v uporabno toploto, prav tako je jasno, če upoštevamo ceno elektrike za gospodinjstva, da imajo takšni sistemi dobro prihodnost.

Odslej potrebne tehnologije obstajajo in glavno vprašanje je, kako doseči ravnovesje med delovnimi urami in shranjeno/toplotno izgubo, prav tako kakor število enot začetka/konca. Še vedno primanjkuje informacij o zanesljivosti in učinkovitosti Stirlingovega motorja, prilagodljivosti plinskih motorjev in dobi trajanja bencinskih celic. Na splošno je priznano, da bodo omenjena vprašanja in nepoznana dejstva, dokazana v naslednjih dveh ali treh letih, tudi izpolnitev specifičnih tehnologij bo prav tako dokazana. Domneva se, da lahko pričakujemo prvi tržni sistem podobne vrste že v petih letih [6], tržno uporabo pa kasneje. Vsekakor bo omenjeno neposredno povezano s procesom razvoja in sprostitve energijskega tržišča.

2 RAZVOJ OGRODJA ZA KOGENERACIJSKI OPK SISTEM

2.1 Tržne prednosti

Zgornji opis ponazarja tehnične zmožnosti kogeneracije in trigeneracije OPK sistemov, toda končno uvajanje takšnega sistema ima edino pomen, če ga je mogoče uskladiti s tržnimi možnostmi. Koristnost kogeneracijskih sistemov je vnaprej odvisna od (1) razlike med odpravno ceno elektrike in ceno goriva, (2) števila obratovalnih ur sistema in (3) potrebne investicije.

Na podlagi poenostavljenega ekonomičnega modela, kjer predstavljamo, da je cena proizvedene toplote enaka kakor pri običajnih sistemih, tako da je cena pridobljene elektrike preračunana s to vrednostjo in lahko preprosto prikažemo investicijsko odplačilno dobo, in sicer:

$$PB = \frac{INV}{H \cdot SV} \quad (2)$$

kjer pomenijo: *INV* - totalni znesek potrebne investicije (\$), *H* - letno obdobje obratovanja naprave (h), *SV* - odpravno ceno ure obratovanja (\$/h). Slednje se lahko izračuna kot:

$$SV = EP \cdot \left(Ea - \left[\frac{F - Fa \cdot \frac{\eta_t}{\eta_{ref}}}{\eta_e} \right] - MC \right) \quad (3)$$

development of micro-cogeneration that is intended for household applications, providing a thermal output of 10 – 25 kW_t and an electric output of less than 10 kW_e. Such micro-cogenerations are based on Stirling engines, fuel cells or small gas engines. As a fuel they use natural gas or LPG (Liqueid Petroleum Gases), and offer overall primary energy utilization up to 95 percent with low NO_x, CO and hydrocarbon emissions. In comparison with conventional gas central-heating boilers for households where 80 – 90 percent of primary energy (natural gas) is transformed to useful heat, and taking into account the price of electricity for households, it is clear that such systems have a promising future.

So the required technologies exist and the main issue is how to reach a balance between running hours and storage/heat losses, as well as the number of unit starts/stops. There is also still a lack of information on reliability and efficiency of Stirling engines, the flexibility of gas engines and the timescale for fuel cells. It is generally accepted that these problems and unknowns will become established within the next two or three years, although the specific technology to be implemented will also have to be proven. It is expected that the first commercial system of this kind can be expected in five years [6], although real commercial exploitation will arrive later. Progress will be directly connected to the development process and deregulation of the energy market.

2 THE FRAMEWORK FOR COGENERATION-HVAC SYSTEMS DEVELOPMENT

2.1 Economic benefits

The above description illustrates the technical viability of cogeneration and trigeneration HVAC systems, but the final adoption of such systems will only make sense if it is accompanied by economic feasibility. The profitability of cogeneration systems primarily depends on (1) the difference between the avoided electricity cost and the fuel cost; (2) the number of system operation hours and (3) required investment.

Based on a simplified economic model that assumes that the price of the produced heat is equal to a conventional system so that the cost of generated electricity is calculated with this value, the simple payback period of investment can be calculated as the follows:

Where *INV* is the required investments (\$), *H* is the annual plant operation period (h) and *SV* represents the avoided costs per hour of operation (\$/h). *SV* can be calculated as:

$$SV = EP \cdot \left(Ea - \left[\frac{F - Fa \cdot \frac{\eta_t}{\eta_{ref}}}{\eta_e} \right] - MC \right) \quad (3)$$

kjer so: EP - električna moč obrata (kW_e), Ea - povprečna električno odpravna cena ($\$/kWh_e$), F - cena goriva za kogeneracijo ($\$/kWh_e$), Fa - odpravna cena goriva ($\$/kWh_e$), MC - cena vzdrževanja kogeneracije ($\$/kWh_e$), $\$$ - upoštevana valuta za investicijo, η_t - toplotni izkoristek kogeneracije, η_{ref} - toplotni izkoristek kotla in η_e - električni izkoristek kogeneracije.

Investicijski stroški všteti sistemov vsebujejo stroške samega kogeneracijskega obrata, električne opreme, prilagoditev sedanjega OPK sistema, hladilni stroj in ventilator ter druge instalacijske stroške. Cena samega kogeneracijske naprave je v obsegu od 400 do 700 USD/ kW_e za majhne enote, do 300 do 400 USD/ kW_e za večje enote. Totalni investicijski stroški celotnega sistema (brez absorpcijske hladilne naprave) so v obsegu od 1100 do 1800 USD/ kW_e za manjše enote, do 550 do 700 USD/ kW_e za večje enote [7].

Če je sistem konstruiran kot trigeneracijski, kar pomeni z absorpcijsko hladilno napravo, se investicijski stroški povečajo v območju od 200 do 300 USD/ kW_e za majhne enote in za večje enote približno do 100 USD/ kW_e [7].

Navedene številke so le primer, da bi ovrednotili projekt, je za vsako lokacijo potrebno proučiti njegovo primernost na osnovi zapletenih ekonomskih modelov, trenutnih cen in stroškov. Izkušnje evropskih držav nakazujejo, da je verjetni odplačilni čas za srednje in večje kogeneracijske in trigeneracijske OPK sisteme okoli štiri do sedem let [7]. Razumljivo, da je vse omenjeno odvisno od številnih dejavnikov, pravnih ureditev in zakonodaje, prav tako od goriva in električne tarife v obravnavani državi.

2.2 Kogeneracijske ovire

Čprav je kogeneracija je odobrena s tehničnega (energija) vidika, skupaj z očitnimi okoliškimi in tržnimi prednostmi, pa se pogosto zgodi, da kogeneracija ni dobro prepoznavna ali definirana v pravni obliki in v predpisih posamezne države. Najbolj pogoste kogeneracijske ovire, ki so bile lahko odkrite, so:

- ni primerne zakona za prodajo in nakup električnega presežka kogeneracijskega obrata ali nezadovoljive (nespodbudne) tarife, razen običajnih visokih tarif za vršne moči (za stanje pripravljenosti in podpiranja) iz energijskega sistema;
- nezadovoljive tarife naravnega plina in drugih goriv za kogeneracijske obrate;
- dolgi in birokratski postopki za pridobitev potrebnih dovoljenj in pogosto administrativnih ovir;
- omejitve glede razpoložljivega povezovanja in uporabo distribucijskega omrežja za generirano elektriko;

Where EP is the electrical power of the plant (kW_e), Ea is the average avoided electricity cost ($\$/kWh_e$), F is the cost of the fuel for cogeneration ($\$/kWh_e$), Fa is the avoided fuel cost ($\$/kWh_e$), MC is the cost of cogeneration maintenance ($\$/kWh_e$), $\$$ is considered the currency for investment, η_t is the thermal performance of cogeneration, η_{ref} is the thermal performance of the referent boiler and η_e is the electrical performance of cogeneration.

The investment costs of the considered systems include the cost of the cogeneration plant, electrical equipment, adaptation of the existing HVAC system, engine cooling and ventilation and other installation costs. The price of the cogeneration plant ranges from 400 to 700 USD/ kW_e for small units, to 300 to 400 USD/ kW_e for large units. The total investment costs for a complete system (without absorption chiller) range from 1100 to 1800 USD/ kW_e for smaller systems, to 550 to 700 USD/ kW_e for large systems [7].

If the system is designed for trigeneration, which means it includes an absorption chiller, investment costs are increased by 200 to 300 USD/ kW_e for small units, to about 100 USD/ kW_e for bigger units [7].

These figures are only given as a reference, a feasibility study is required to validate the project for each location with complex economic models and actual prices and costs. The experience of European countries shows that the probable payback period for medium and large cogeneration and trigeneration HVAC systems is about four to seven years [7]. Obviously this depends on several factors, particularly the regulation and legislation framework, as well as fuel and electricity tariffs in the respective countries.

2.2 Barriers to cogeneration

Even if cogeneration is accepted from the technical (energy) point of view, together with its evident environmental and economic advantages, it is often the case that the position of cogeneration is not clearly recognized or defined in the legal framework and regulations of an individual country. The most common barriers to cogeneration are as follows:

- No appropriate law for buying and selling surplus electricity from cogeneration plants or unsatisfactory (non-stimulating) tariffs. In addition to typically high tariffs for stand-by and back-up peak power from a power system;
- Unsatisfactory tariffs for natural gas and other fuels for cogeneration plants;
- Long and bureaucratic procedures for the procurement of necessary authorizations and administrative barriers;
- Rules regarding connection availability and the use of the distribution network for generated electricity;

- dolg odplačilni čas zaradi neprimerne tržne in pravne oblike;

Skupaj z razvojem energijskega trga in z ureditvijo v evropskih državah, je mnogo omenjenih ovir znižanih ali popolnoma odstranjenih. Vendar, odkar je izvedba kogeneracijskega in trigeneracijskega OPK sistema povezana s povečanimi investicijskimi stroški v primeri z običajnimi sistemi, je treba analizirati vsak projekt preden je izveden. Na tej stopnji je prav tako zelo pomembno ugotoviti, ali zakon obsega vse ključne točke, ki se nanašajo na kogeneracijo in druga vprašanja ali pa se je treba o njih pogajati, da bi se izognili vsem problemom.

3 PRIMER OPK SISTEMA V BOLNIŠNICI

Z željo, da bi povezali zgornja razmišljanja z dejanskim stanjem, bomo predstavili analizo primernosti za trigeneracijski sistem v hrvaški bolnišnici. Bolnišnica je v mestu Zagreb z značilnostmi celinskega podnebja. Bolnišnica je sodoben objekt, končan leta 1988, z načrtovano velikostjo 755 ležišč in kasneje skrčeno približno na 500 ležišč.

Energijske potrebe bolnišnice so tipične za takšne objekte: (a) primarna: elektrika, hišna vroča voda, ogrevanje (pozimi) in hlajenje (poleti); ter (b) sekundarna: pranje, sterilizacija in sežiganje.

- Long payback period due to an inadequate economic and legal framework.

In combination with energy-market development and deregulation in European countries, many of these obstacles are being reduced or completely removed. However, since the implementation of a cogeneration- or trigeneration-HVAC system is linked with increased investments in relation to conventional systems and viability depends on several different issues, it is necessary to analyze each project before its realization. At this stage it is also very important to find out if the law covers all the points relating to cogeneration and other subjects or if it is necessary to negotiate them, to prevent any problems.

3 EXAMPLE OF A HVAC SYSTEM IN A HOSPITAL

To link the above considerations to a real situation we will present an example of a feasibility analysis for a trigeneration system in a hospital in Croatia. The hospital is located in Zagreb with a continental-type climate. The hospital is a modern building finished in 1988, with a projected size of 755 beds later reduced to about 500 beds.

The energy needs of the hospital are typical for such an institution: (a) primary - electricity, domestic hot water, heating (winter), and cooling (summer); and (b) secondary - laundry,

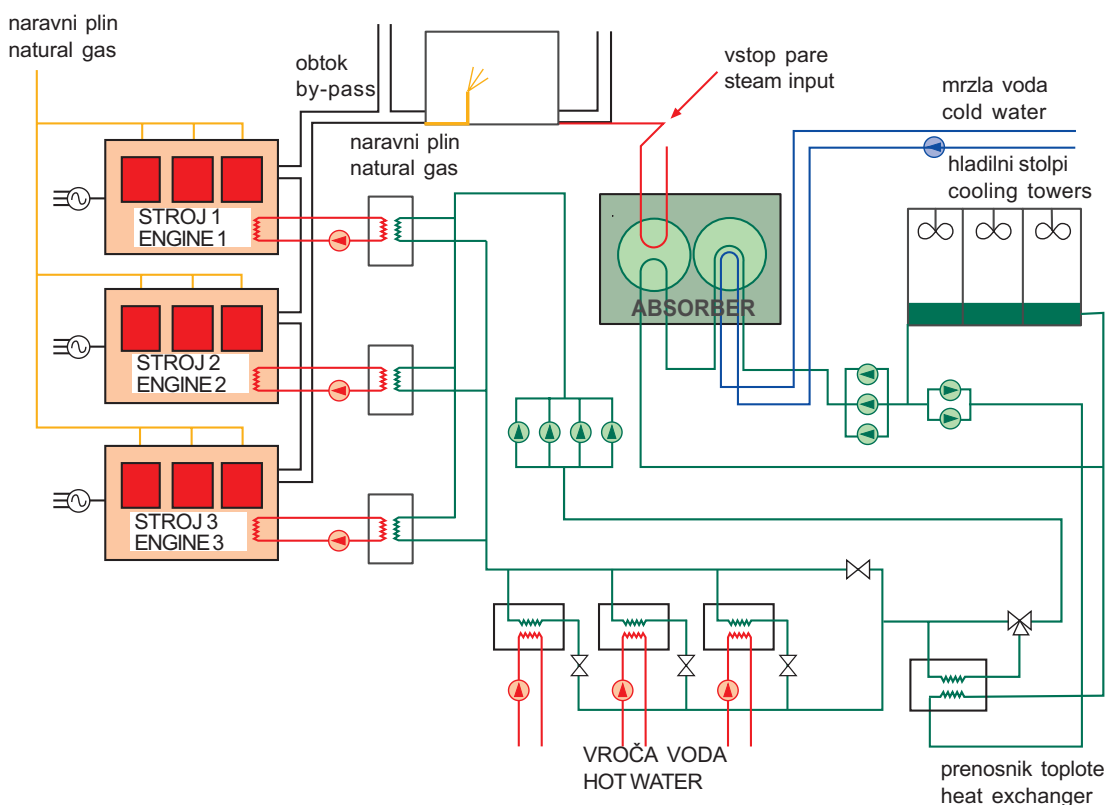

Sl. 5. Shema novega sistema
Fig. 5. Scheme of new system

Sedanji OPK sistem vključuje enostopenjsko absorpcijsko hladilno napravo, ki deluje na paro iz sedanjih kotlov.

Glede na dejstvo, da bolnišnica deluje vse leto, tudi energetski sistem deluje nepretrgano celo leto. Analizirane so možnosti uvedbe kogeneracijskega postrojenja, ki bi pokrilo vse ali del potreb po energiji.

Celotna letna poraba elektrike znaša približno 15,5 GWh s pogodbeno močjo 2200 kW. Celotna proizvodnja pare znaša približno 73 000 ton na leto, od tega so potrebe za ogrevanje in hlajenje (absorber) približno 59 000 ton. Celotna letna poraba naravnega plina znaša 5 000 000 m³, od tega porabi ogrevanje in hlajenje skoraj 4 750 000 m³.

Parni proizvodni obrat je sestavljen iz treh kotlov z vgrajeno zmogljivostjo 3 x 6 000 kW, tlaka 10 bar in zmogljivostjo okoli 9 ton/h pri 185 °C. Za proizvodnjo hladilne energije se uporabljata enostopenjska absorpcijska hladilnika z vgrajeno zmogljivostjo 2 x 2700 kW (0,8 bar). Para se uporabi pri toplovodnih ogrevalnih sistemih (110/70 °C) skozi štiri prenosnike toplote z zmogljivostjo 4 x 800 kW.

Analizirana je vgradnja kogeneracijskega obrata, ki bi deloval neprestano vse leto. Tehnična zamisel projekta vključuje vstavev enega ali več plinskih (Ottovih) batnih strojev, ki lahko pridobivajo elektriko, vročo vodo in nizko tlačno paro. Slika 5 prikazuje shemo predlaganega sistema.

Analizirane so tri različne izbire: (A) vgradnja enega stroja z zmogljivostjo 3,8 MW_e, (B) vgradnja dveh strojev z zmogljivostjo 2 x 2,9 MW_e in (C) vgradnja treh strojev z zmogljivostjo 3 x 1,0 MW_e. Izbor se spreminja samo z velikostjo obrata, torej različno porabo goriva v kogeneraciji in največjo obremenitvijo kotlov (sedanjih), prav tako je različna proizvodnja elektrike, ki se uporabi na lokaciji, ali se proda javnim uporabnikom. Omenjene vrednosti niso prikazane spodaj, so pa vključene v izračun. Osnovna predpostavka preračunavanja je, da je električni presežek lahko prodan javnim uporabnikom za ceno 85 % povprečne električne cene (5,5 USc/kWh), naravni plin je po 13,5 USc/m³ in cena pogodbene rezervne moči na višini 50%. Finančni stroški so preračunani na podlagi predpostavke investicijskih financ pri 30/70-odstotni stopnji (lastni kapital/kredit), s 15-odstotnim deležnim razmerjem in s 5-letnim odplačilnim obdobjem.

Preglednica 1 podaja rezultate analize, ki temeljijo na teh predpostavkah. Zaradi občutljivosti projekta preglednica 2 podaja analizo podobnih primerov s spremenjenimi cenami naravnega plina in električnimi tarifami.

Omenjeni rezultati prav tako kakor prejšnji zaključki prikazujejo, da pri analiziranem primeru ni tehničnih problemov pri kogeneracijski izvedbi. Končni odgovor in odločitev sta odvisna samo od

sterilization and hospital-waste incineration. The existing HVAC system includes a single-stage absorption chiller operated by steam from existing boilers.

As the hospital works during the whole year, the energy system also runs continuously during year. The possibility of introducing a cogeneration plant that would cover all or part of the energy demands is analyzed.

The total annual electricity consumption is about 15.5 GWh with contracted power of 2200 kW. Total steam production is about 73 000 t per year, the requirements for heating and cooling (absorber) are about 59 000 t. Total annual natural gas consumption is about 5 000 000 m³ of which heating and cooling consume almost 4 750 000 m³.

The steam production plant consists of three boilers with a capacity of 3 x 6 000 kW, pressure 10 bar and production capacity of about 9 t/h at 185°C. For cooling-energy production, two single-stage absorption chillers are used with an installed capacity of 2 x 2 700 kW (0.8 bar). The steam is used in a warm-water heating system (110/70°C) through four heat exchangers with a capacity of 4 x 800 kW.

The installation of a cogeneration plant that would run continuously over a year is analyzed. The technical concept of the project includes the embedding of one or more gas (Otto) reciprocating engines that would generate electricity, hot water and low-pressure steam. Figure 5 shows a scheme of the proposed system.

To find the optimum economic viability, three different options are analyzed: (A) installation of one engine with a capacity of 3.8 MW_e; (B) installation of two engines with capacity 2 x 2.9 MW_e and (C) installation of three engines with capacity 3 x 1.0 MW_e. The options only vary in terms of plant size, and consequently the different fuel consumption of cogeneration and peak boilers (the existing ones), as well as the different electricity production that is used in a location or sold to the public grid. These values are not shown below, but are included in the calculations. The basic assumption of the evaluation is that the electricity surplus can be sold to the public grid for 85% of the average electricity price (5.5 USc/kWh), natural gas 13.5 USc/m³ and contracted back-up power cost at the 50% level. The costs are calculated assuming investment finance at the 30/70 percent level (own funds/ credit), with a 15% interest rate and a 5-year payment period.

Table 1 gives the analysis results based on these assumptions. Due to the estimation of project sensibility, table 2 gives analysis of the same cases with altered prices of natural gas and electricity tariffs.

These results, as well as the previous conclusions show that no technical difficulties for cogeneration implementation in the analyzed hospital are present. The final answer and decision depends only on the circumstances of fuel supply and

Preglednica 1. *Vpeljivost kogeneracije v bolnišnici*Table 1. *Cogeneration viability in hospital*

	Primer (A) Option (A)	Primer (B) Option (B)	Primer (C) Option (C)
celotna investicija v USD overall investment in USD	2 550 000	3 900 000	2 400 000
odplačilni čas payback period	3,0	3,0	2,6
odplačilni čas (finančni) payback period (financial)	3,5	3,6	3,3
I.R.R. v % (10 let, finančno) I.R.R. in % (10 years, financial)	27	27	30

Preglednica 2. *Občutljivost projekta pri spremembi vstopne cene*Table 2. *Project sensibility at input price change*

Odplačilni čas Payback period	Primer (A) Option (A)	Primer (B) Option (B)	Primer (C) Option (C)
naravni plin: 23,2 USc/m ³ natural gas: 23.2 USc/m ³	9,0	8,7	5,9
prodajni električni presešek: 4,5 USc/kWh selling electricity surplus: 4.5 USc/kWh	5,6	6,0	4,3

nabave goriva in električne tarife, ki imata velik vpliv na izvedbo projekta.

electricity tariffs that have a significant influence on the project feasibility.

4 SKLEP

Kogeneracijski sistemi ali njihove uporabe se v velikih in srednjih OPK sistemih lahko štejejo kot upravičena tehnologija za proizvodnjo toplote in moči. Sistemi so delno koristni, ko se uporabljajo za hlajenje z absorpcijskimi hladilniki, kar je prepoznavno kot trigeneracija. V takšnih primerih neprestano delovanje vse leto doseže največjo izkoriščenost energije, gospodarske in okoljske prednosti trigeneracijskega (ali kogeneracijskega) sistema.

Izkušnje prikazujejo, da so najprimernejša primarna sredstva za OPK sisteme batni stroji z notranjim zgorevanjem. Omenjeni kogeneracijski sistemi imajo zelo velik izkoristek uporabe primarnega goriva, celo čez 85 odstotkov, zaradi dajanja toplotne energije, ki je primerna za uporabo v OPK sistemu. Prav tako je proizvodna toplota primarna za pogon absorpcijskih hladilnikov, hladilne značilnosti so ponovno izbrane za OPK sisteme. Vzporedna zvezna proizvodnja elektrike lahko zajamči potrebno moč za delovanje vseh naprav znotraj OPK sistema in s časom se lahko uporabi presežek na kraju samem ali pošlje javnim uporabnikom.

Zaradi velike učinkovitosti uporabe goriva in običajne uporabe naravnega plina ali nekateri druga okolju koristna goriva, imajo kogeneracijski obrati majhno oddajo CO₂, SO₂ in NO_x, tako ti sistemi znatno prispevajo k varstvu okolja. Z upoštevanjem teh dejstev, prav tako pa stalne potrebe po gradnji novih energijskih obratov in toplotnih enot, kakor tudi zaradi vedno bolj strogih predpisov na področju

4 CONCLUSION

Cogeneration systems, or better their application in large and medium HVAC systems, can be seriously considered as a justified technology for heat and power production. These systems are particularly advantageous when they are used for cooling by the absorption chillers, which is then recognized as trigeneration. In such cases, continuous operation during a whole year is obtained with the maximum utilization of energy.

Experience shows that the most appropriate prime movers for HVAC systems are internal combustion reciprocating engines. Such cogeneration systems have a very high efficiency of primary fuel utilization, possibly over 85 percent, through the assurance of heat energy that is exactly suitable for HVAC-system consumption. Also the produced heat is appropriate to run absorption chillers, whose chilling characteristics are again suitable for HVAC systems. In addition, parallel continuous electricity production can guarantee the required power for the operation of all equipment within the HVAC system, and eventually surplus energy can be used at the location or transferred to the public grid.

Due to the high efficiency of fuel utilization and the use of natural gas or some other environmental advantageous fuels, cogeneration plants have low CO₂, SO₂ and NO_x emissions, so these systems contribute considerably to the protection of the environment. Taking into account these facts, as well as permanent need for the construction of new power

energijskega gospodarjenja, investicijske realizacije in varstva okolja, v razviti državah dandanes pogosto uporabljajo opisane sisteme.

Zares pri vpeljivosti postrojenja ne smemo spregledati možne vpeljave kogeneracijskih in trigeneracijskih sistemov, kar pomeni analizo gospodarskih in finančnih prednosti v primerjavi s tradicionalnimi OPK sistemi. Prispevek prikazuje poenostavljen gospodarski model in prav tako primer konkretnega projekta z gospodarskimi rezultati kogeneracije ter sedanji OPK sistem v bolnišnici na Hrvaškem. Kogeneracija ali boljše trigeneracija je najprimernejša tehnologija za proizvodnjo elektrike, toplote in hladilne energije. Investicijski odplačilni čas podobnih OPK sistemov je, glede na izkušnje iz Zahoda, med štirimi in šestimi leti. Opisan sistem je odvisen od velikosti postrojenja, vračila investicije v času 3,3 do 3,6 let, pomembna je njena občutljivost na izstopne parametre (cene plina in elektrike). Nespremenjeni projekti v nenaklonjenih okoliščinah lahko povrnejo investicijo najkasneje po devetih letih.

Vsi omenjeni razlogi upravičujejo vpeljavo kogeneracijskih in trigeneracijskih OPK sistemov. Pred končnimi sklepi pa je treba izvesti podrobne analize.

5 LITERATURA

5 REFERENCES

- [1] Donjerković, P., I.Balen (1997) Gas as an energy source in heating, ventilating and air-conditioning systems. *Zbornik: Međunarodni simpozij o grijanju, hlađenju i klimatizaciji Interklima, 14, Zagreb.*
- [2] Orlando, J.A. (1997) Cogeneration planner's handbook. *PennWell Publishing Company, Orlando.*
- [3] Institut Catala d'Energia (1993) Cogeneracio amb motores alternatius. *Generalitat de Catalunya, Barcelona.*
- [4] Vicens, S.I.(1994) La absorcion como complemento de la cogeneracion en el sector terciario, Oilgas.
- [5] Šunić, M. (1997) Mogućnost hlađenja plinom. *Zbornik: Međunarodni simpozij o grijanju, hlađenju i klimatizaciji Interklima, 14, Zagreb.*
- [6] Harrison, J. (1999) The implications of micro CHP for Energy Companies. Sigma Elektrotehnik AS.
- [7] Petrić, H., et al. (1998) KOGEN: Program kogeneracije: Prethodni rezultati i buduće aktivnosti. *Energetski institut "Hrvoje Požar", Zagreb.*

Naslova avtorjev: prof.dr. Petar Donjerković

Fakulteta za strojništvo in
ladjedelništvo
Univerze v Zagrebu
Ivana Lučića 5
10000 Zagreb, Hrvatska

Hrvoje Petrić
Energetski institut "Hrvoje Požar"
Ulica grada Vukovara 37
P.P. 141
10001 Zagreb, Hrvatska

Authors' Addresses: Prof.Dr.Petar Donjerković
Faculty of Mechanical Eng.
and Naval Architecture
University of Zagreb
Ivana Lučića 5
10000 Zagreb, Croatia

Hrvoje Petrić
Energy Institute "Hrvoje Požar"
Ulica grada Vukovara 37
P.O.Box 141
10001 Zagreb, Croatia

Prejeto:
Received: 15.8.2000

Sprejeto:
Accepted: 10.11.2000